

# FIVE THINGS YOU NEED TO KNOW

*May 9, 2023*



# Clearfield Leadership Academy

- *13 participants*
- *13 total sessions*
  - *3 Leadership Sessions*
  - *3 Management Sessions*
  - *Book reports*
  - *“Tour de Clearfield” – job shadowing*



Not pictured:  
Christina Arbogast, Jeremy Graves, Ricki Miller, Brad Wheeler

# Spring Run Off and Potential Flooding

- *Private vs. Public Property Flooding*
  - *20 reports water in basements (none were caused by City owned infrastructure failures)*
  - *Run off from Miya's Farm (Weber Basin Property)*
  - *Valhalla Area*
    - Preventative and ongoing maintenance
  - *Storm Drain System*
    - 7 Regional Detention Ponds (total capacity 178.8 acre-foot)
    - H Street storm drain line
    - Areas with no curb and gutter
    - Areas with secondary non-pressurizes irrigation
    - State Street and 1450 S.
    - Isolated flooding due to debris
    - 5 Annual Maintenance Areas and several feet of open drainage ditch

# 200 S. Well / Mabeey Pond Water Supply

- Vendor believed there were issues with the shaft
- New submersible pump installed (250 GPM, 360K/day) 4.6 months
- Problems maintaining pressure/volume at full power
  - Pumping @ approximately 135 GPM (194,400 gallons per day, 8.5 months)
  - Adding pressure transducer in May (@ 150 GPM, 216k gallons/day 7.7 months)
- If issues resolved we can pump at 250 GPM (306k gallons/day, 4.6 months)
  - Started pumping April 11 part time (64,800 gallons/day, 324k gallons/week)
  - Pumping 24/7 since April 18 (194k gallons/day, 22 days = 4.268M gallons + 324K=4.592M +/- 10%)
- **Long term recommendation: Install surface mounted vertical shaft pump \$92-100,000** (Installation & Startup) 60hp 450GPM
  - (648k gallons/day, 2.6 months to fill)

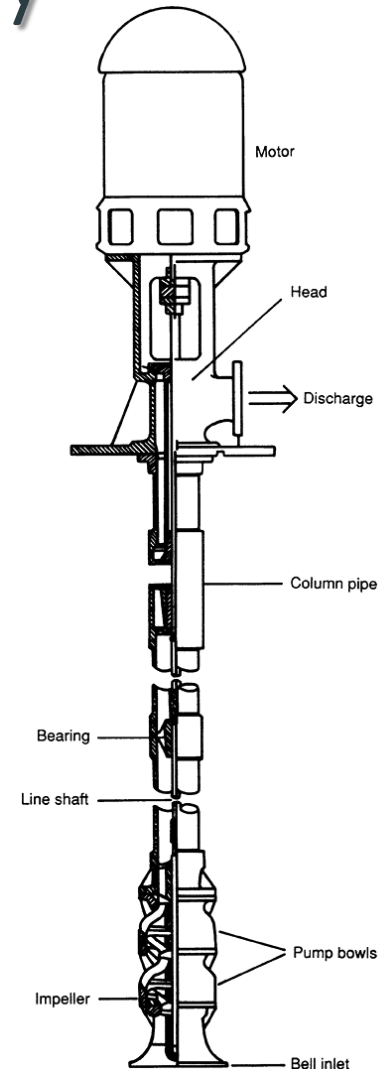

# WAVE Wearable Devices



- *Drowning prevention system*
- *Began Implementation on May 1*
- *Required for all patrons under 12*
- *Initial feedback*
  - *Social media—opposition to mandatory use*
  - *Users at the center— Generally positive*
  - *Staff challenges – Enforcement concerns*



## July 4th Events

Paint the Bridge	June 26, 7:30 pm
Search the City	June 26-July 1
Movie in the Park	July 1, 8:30-11:30 pm
Patriotic Concert	July 2, 7:30 pm
Pool Bash	July 3, 7:30-9:30 pm
Fun Run/Walk	July 4, 7:00 am
Parade	July 4, 9:30 am
Park Festival	July 4, 6:00-10:30 pm

