

# Mapleton City Network

## Standard Specifications and Drawings



August 15, 2022

# Table of Contents

## Standard Specifications

Section 1: Aerial and Underground Infrastructure

Section 2: Junction Box and Pedestal

Section 3: Communications Cabling and Testing

## Standard Drawings

SD-01: Aerial, Riser and Alpha Cabinet Details

SD-02: Trenching Details

SD-03: Junction Box Details

SD-04: Marker Post Details

SD-05: Calix E3-2 Module Mounting Details

SD-06: Typical PON Splitting & Fusion Splice Details

SD-07: Typical PON Splitting & Fusion Splice Details

SD-08: Residential Conduit Installation

SD-09: Commercial Conduit Installation – Option 1

SD-10: Commercial Conduit Installation – Option 2

SD-11: Microtrench Installation Details

## Appendix

Appendix A: Quazite Junction Box

Appendix B: Channell Pedestal

Appendix C: AFL Splice Enclosure and Splitter

Appendix D: Alpha Power Supply Cabinet

Appendix E: Calix E3-2 Module

## SECTION 1

# AERIAL AND UNDERGROUND INFRASTRUCTURE

### PART 1 GENERAL

#### 1.1 SECTION INCLUDES

- A. Materials and procedures for installing underground infrastructure according to the contract. Install conduit by trenching, boring, or plowing unless otherwise specified. Install microduct by microtrenching.
  - 1. Conduit, tracer wire and all materials, labor, workmanship, equipment, and incidental items required for a complete system of underground infrastructure.
- B. Materials and procedures for installing aerial infrastructure according to the contract.
  - 1. Steel strand, lashing wire, galvanized hardware and all materials, labor, workmanship, equipment, and incidental items required for a complete system of aerial infrastructure.

#### 1.2 RELATED SECTIONS

- A. Section 2: Junction Box and Pedestal
- B. Section 3: Communications Cabling and Testing

#### 1.3 REFERENCES

- A. ANSI C135.1: Zinc-coated Steel Bolts and Nuts for Overhead Line Construction
- B. ASTM A 108: Steel bars, Carbon, Cold-Rolled
- C. ASTM A 123: Zinc (Hot-Dip Galvanized) Coatings on Iron and Steel Products
- D. ASTM A 153: Zinc Coating (Hot-Dip) on Iron and Steel Hardware
- E. ASTM A 307: Carbon Steel Bolts, Studs and Threaded Rod 60000 PSI Tensile Strength
- F. ASTM A 475: Zinc Coated Steel Wire Strand
- G. ASTM A 510: General Requirements for Wire Rods and Coarse Round Wire, Carbon Steel

- H. ASTM B 695: Coatings of Zinc Mechanically Deposited on Iron and Steel
- I. ASTM D 2241: Poly-Vinyl Chloride (PVC) Pressure-Rated Pipe (SDR Series)
- J. ASTM F 2160: Solid Wall High Density Polyethylene (HDPE) Conduit based on Controlled Outside Diameter (OD).
- K. National Electrical Code (NEC)
- L. National Electrical Manufacturers Association (NEMA)
- M. National Electrical Safety Code (NEC)
- N. State of Utah Administrative Rule R930-6 – Accommodation of Utilities and the Control and Protection of State Highway Rights of Way
- O. Underwriters Laboratory (UL)
- P. USDA Rural Utilities Service (RUS) Specifications

#### **1.4 SUBMITTALS**

- A. Submit manufacturer documentation to the City for all Contractor provided equipment and materials for acceptance prior to installation.
- B. Backfill:
  - 1. Supplier and source.
  - 2. Sieve analysis.
  - 3. Soil classification.
  - 4. Maximum dry density and optimum moisture.
- C. Flowable fill, concrete and/or asphalt mix design for City's approval.

### **PART 2 PRODUCTS**

#### **2.1 MATERIALS**

- A. Conduit and fittings:
  - 1. Schedule 40 PVC rated at 194 degrees F as specified in NEMA TC-2, NEMA TC-3, ASTM D 2241, UL Listed.
  - 2. High Density Polyethylene (HDPE) SDR11 rated as specified in ASTM F 2160.

3. Rigid steel (RMC or IMC) as specified in UL-6. Galvanized as specified in ANSI C80.1
  4. HDPE microduct, 18/14mm.
- B. Meet or exceed all of the conduit manufacturer's recommendations for all materials used in the installation of conduits including sweeps, adapters, couplings, glue, plugs, and fittings.
- C. Couplings and fittings must provide watertight integrity.
- D. Sweeps – Factory manufactured sweeps (22½, 45, and 90 degree angles) complete with bell and spigot.
- E. Tracer wire – 12-gauge solid THWN.
- F. Pull tape – Flat profile, low stretch polyester, sequential footage marked, 1,250 lbs. tensile strength.
- G. Fiber optic and electrical buried warning tape:
  1. Material – Composite reinforced thermoplastic.
  2. Tape Color – Orange (communication) or Red (electric).
  3. Text – “Caution - MCN Fiber Optics Buried Below” or “Caution - MCN Electric Buried Below”.
  4. Maximum distance between text is 5 feet.
  5. Text Color – Black.
  6. Width – 3-inch.
- H. Aerial:
  1. 5/16-inch EHS Class A steel strand.
  2. Stainless steel lashing wire.
  3. Galvanized hardware – 5/8-inch standard hardware, three-bolt suspension clamp, D lashing clamp, bonding clamp, thimble eye nut, preformed dead-end grip, guy hook, machine bolt, drop clamps, etc.
  4. Down guy and anchor:
    - a. Anchor with thimble eye nut anchor rod. (Type and length determined by soil conditions and according to manufacturer specifications)
    - b. Yellow plastic, high visibility guy wire marker, 8 feet length minimum.
    - c. Porcelain down guy insulator.
  5. Fiber cable storage bracket (sno-shoe) sized to maintain minimum fiber optic cable bend radius.

## **PART 3 EXECUTION**

### **3.1 GENERAL**

- A. Base final conduit routing on actual field conditions at the time of construction to prevent conflicts with existing utilities including Blue Stake markings.
- B. Obtain appropriate permits before work begins.
- C. Maximum spacing between junction boxes – 2,500 feet.
- D. Minimum cover of conduit:
  - 1. Electrical – 36 inches minimum.
  - 2. Communications – 36 inches minimum.
    - a. 6-12 inches above electrical conduit in joint trenches.
  - 3. Microtrench – 15 inches minimum.
  - 4. Residential Drop – 18 inches minimum.
  - 5. Commercial Drop – 36 inches minimum.
- E. The City will not grant additional time or money for installing conduit in difficult subsurface conditions.
- F. Obtain City approval prior to installation of any underground or aerial infrastructure, ensuring underground and pole attachment permitting has been obtained.

### **3.2 INSTALLATION**

- A. Prevent conduit from deflecting vertically or horizontally along its length by a ratio greater than 10:1, (no more than 4-inch deflection per 40 inch in length) when installing conduit that houses communication cable.
- B. Prevent sum total of the vertical and horizontal conduit deflection or bend between any two junction boxes from exceeding 270 degrees when installing conduit.
- C. Minimum conduit bend radius – 36 inches.
  - 1. 90-degree RMC/IMC sweeps must be factory manufactured.
  - 2. Field bending of conduit using heat methods is not allowed.
  - 3. Adhere to manufacturer's specifications for microduct bend radius according to duct size.
- D. Install conduits that cross finished curbs and gutters, sidewalks, concrete flatwork, or textured or decorative surfaces by boring, jacking, or drilling.

Replace entirely any damaged concrete sections, joint to joint, at no additional cost to the City.

- E. Provide pull tape in all conduits:
  - 1. Install continuously between junction boxes.
  - 2. Fasten ends securely within each junction box, pad or enclosure at each conduit end, and provide 3 feet of pull tape slack.
  - 3. Do not splice pull tape in conduit.
  
- F. Tracer wire:
  - 1. Tracer wire installed within one conduit of each duct bank run, and in within same conduit as communications cable if applicable.
  - 2. Provide 3 feet of tracer wire slack at each conduit end.
  - 3. Install tracer wire only when duct bank doesn't contain a locatable fiber optic cable.
  
- G. Limit cable percentage fill in conduit to the maximum allowed by NEC and RDUP requirements.
  
- H. Riser conduits:
  - 1. Use 3-inch RMC or IMC conduit for above grade application.
  - 2. Apply 2-inch width anti-corrosion protection tape to any portion of RMC or IMC conduit that's below grade, extending a minimum of 6 inches above grade.
  - 3. Install two 1-inch HDPE conduits within riser, between junction box and top of riser. Use conduit plugs and/or duct seal material to plug all conduits at top of riser.
  
- I. Warning tape:
  - 1. 3-inch – In trench above conduits, 12 inches below grade.
  - 2. Not required when boring conduit.
  
- J. Furnish and install utility marker posts to identify the presence of an underground duct bank/junction box system.
  - 1. Required in rural areas only,
  - 2. Signage to include the following information:
    - a. "Warning: Buried Utilities".
    - b. "In Case of Damage Call Mapleton City Network 801-489-6253".
  - 3. Install marker posts:
    - a. At each junction box.
    - b. Between junction boxes near the midpoint of each duct bank segment.
    - c. Near each road crossing or any major utility crossing.
    - d. Refer to the Standard Drawings.

### **3.3 TRENCH / BORE PIT**

- A. Paved surface:
  - 1. Backfill around conduit with a minimum 12 inches of sand. Backfill above sand with City approved untreated base course material (road base) or flowable fill, according to City requirements.
  - 2. Compact soil under pavement according to City requirements.
  - 3. Install T-patch over trenched area according to the Standard Drawings.
  - 4. Cut pavement from roadway surface to roadway base on both sides of trench to provide a clean, straight wall for T-patch before any backhoe use.
  - 5. Evenly apply tack coat on final backfill before installing T-patch.
  - 6. Restoration patch – match the composition, density, and elevation ( $\pm\frac{1}{4}$  inch), of the existing surface according to City requirements.
  
- B. Sidewalk:
  - 1. Backfill around conduit with a minimum 12 inches of sand. Backfill above sand with City approved untreated base course material (road base) or flowable fill, according to City requirements.
  - 2. Compact soil under sidewalk according to City requirements.
  - 3. Match existing sidewalk thickness. New sidewalk thickness must be 4 inches minimum.
  - 4. Restore sidewalk to original condition or better after work is completed.
  
- C. Unpaved surface
  - 1. Backfill around conduit with a minimum 12 inches of sand.
  - 2. Backfill above sand using native material, if suitable, that matches the composition, density, and elevation ( $\pm 0.2$  inch) of the existing surface, or as directed by the City.
  - 3. Dispose of surplus material daily.

### **3.4 BORE**

- A. Immediately contain, remove, and properly dispose of all drilling fluid outside the bore.

### **3.5 AERIAL**

- A. Tension aerial strand according to the manufacturer's specifications, NESC, and existing field conditions.
  
- B. Use lashing machine to attach cabling to aerial strand using dual lashing wires. Fasten lashing wires for each span using lashing clamps.



- C. Install down guy anchor according to the manufacturer's specifications and at locations required by the local power company.
- D. Bond aerial strand to the pole's ground wire.
- E. Drill holes for bolt and strand attachments for wooden poles and stainless steel straps for metal poles. Do not drill metal poles.
- F. Use wrap-around style fiber optic cable label at each pole. See Section 3 for type.
- G. Meet or exceed all NESC and local power company's requirements.

### **3.6 MICROTRENCH**

- A. Saw cut using approved microtrenching machine.
- B. Minimum microtrench saw cut depth is 16 inches. Typical microtrench saw width is 1 ½ inches.
- C. Install microtrench into travel lane at a 24-inch offset from existing curb and gutter, or from edge of pavement in areas with no curb and gutter.
- D. Install microducts in bottom 1-inch of microtrench.
- E. Backfill:
  1. Flowable fill to 1-inch below existing asphalt roadway grade.
  2. 1-inch of Mastic polymer rubberized material above cured flowable fill to existing asphalt roadway grade.
    - a. Adhere to manufacturer's installation requirements.
- F. Asphalt Coring:
  1. For sweeping of microducts outside of roadway, remove asphalt using a 10-inch core saw/machine. Existing core to be reused during restoration.
  2. Tunnel underneath roadway shoulder or curb and gutter for installation of microducts.
  3. Backfill using flowable fill to bottom of removed core.
  4. Reinstall asphalt core above cured flowable fill using Utilibond. Ensure core is installed flush with surrounding roadway.

### **3.7 REPAIR OR RESTORATION**

- A. Restore all areas, including landscaping, concrete pavement, asphalt, finished curbs and gutters, box culverts, sewers, underground water mains, sprinkler systems, sidewalks, concrete flatwork, colored, textured,

or decorative surfaces damaged during conduit and junction box installation.

- B. Coordinate with local utilities for utility repair.
- C. Notify the Engineer of all necessary repairs.
- D. Replace all damaged facilities in kind.

### **3.8 SERVICE ENTRANCE**

- A. Outdoor Service Drop Conduit Installation:
  - 1. Residential – One ¾-inch HDPE drop conduit between the MCN junction box/pedestal and the City/Owner coordinated demarcation point on the outside wall of the home, typically within 2 feet of the electrical meter.
  - 2. Commercial – One 2-inch HDPE drop conduit between the MCN junction box/pedestal and the City/Owner coordinated demarcation point on the outside wall of each building unit.
  
- B. Premise Conduit Installation:
  - 1. Residential – One 1-inch conduit between the City/Owner coordinated premise communication room and the demarcation point on the outside wall of the home, typically within 2 feet of the electrical meter.
    - a. Premise communication room must have access to a dedicated power outlet for the powering of communications equipment.
    - b. Maximum of 270 degrees total conduit deflection from end to end, and a 36-inch minimum conduit bend radius are required.
  - 2. Commercial – One 2-inch conduit between the City/Owner coordinated premise communication room and the demarcation point on the outside wall of each building unit.
    - a. All conduit passing through concrete must be RMC or IMC.
    - b. Maximum of 270 degrees total conduit deflection from end to end, and a 36-inch minimum conduit bend radius are required.
    - c. All conduit passing through concrete must be RMC or IMC.

END OF SECTION

## SECTION 2

# JUNCTION BOX AND PEDESTAL

### PART 1 GENERAL

#### 1.1 SECTION INCLUDES

- A. Materials and procedures for installing junction boxes, ground rods, pedestals and maintenance markers.

#### 1.2 RELATED SECTIONS

- A. Section 1: Aerial and Underground Infrastructure
- B. Section 3: Communications Cabling and Testing

#### 1.3 REFERENCES

- A. ASTM C 579: Compressive Strength of Chemical-Resistant Mortars, Grouts, Monolithic Surfacing, and Polymer Concretes
- B. ASTM C 580: Flexural Strength and Modulus of Elasticity of Chemical-Resistant Mortars, Grouts, Monolithic Surfacing, and Polymer Concretes
- C. American National Standards Institute (ANSI)
- D. Society of Cable Telecommunications Engineers (SCTE) Standards
- E. Underwriters Laboratory (UL)
- F. USDA Rural Utilities Service (RUS) Specifications

#### 1.4 SUBMITTALS

- A. Submit manufacturer documentation to the City for all Contractor provided equipment and materials for acceptance prior to installation.
- B. Backfill:
  - 1. Supplier and source.
  - 2. Sieve analysis.
  - 3. Soil classification.
  - 4. Maximum dry density and optimum moisture.
- C. Concrete and/or asphalt mix design for City's approval.

## **PART 2 PRODUCTS**

### **2.1 JUNCTION BOXES AND LIDS**

- A. Junction boxes – Precast polymer concrete. Refer to the Standard Drawings for dimensions of junction box types.
- B. Furnish boxes, rings, and lids that meet all the requirements of ANSI/SCTE 77 2017, including Tier 22 loading.
- C. Use lids for all junction boxes specified by application. Manufacture lids with the following markings in the logo area, in 1 inch recessed letters:
  - 1. “MCN Electric” when the junction box contains power conductors.
  - 2. “MCN Fiber Optic” when the junction box contains fiber optic or communications cabling.
- D. Lid Access Points – Recessed reinforced steel pull slots to allow removal of cover with a hook or lever. Replace lid if damage occurs to the pulling point.
- E. Bolts – Stainless steel recessed hex head bolts with washer. Refer to the Standard Drawings.

### **2.2 PEDESTAL**

- A. OSV Optimus Super Vent Pedestal Specifications:
  - 1. Nominal Dimensions:
    - a. Lid height – 22 inches.
    - b. Base height – 24 inches.
    - c. Length – 40 inches.
    - d. Width – 29 inches.
  - 2. Color – Light green.
  - 3. Fiber node bracket included.
  - 4. Hex-head locking mechanism.
  - 5. Refer to the Appendix for detailed product requirements.
- B. Optimus Pedestal Specifications:
  - 1. Nominal Dimensions:
    - a. Lid height – 25 inches.
    - b. Base height – 12 inches.
    - c. Width – 12 inches.
  - 2. Color – Light green.
  - 3. Hex-head locking mechanism.

## **2.3 MAINTENANCE MARKERS**

- A. Furnish and install Utility Marker Posts for each box location as specified in the Plans. Refer to the Standard Drawings.

## **2.4 GROUND ROD**

- A. Ground Rods – 8 ft x 5/8-inch copper-coated steel ground rod as specified by ANSI/UL467.

## **2.5 EXPANSION JOINT MATERIAL**

- A. ½-inch preformed expansion joint material.

## **2.6 PULL TAPE**

- A. Pull Tape – Refer to Section 1.

# **PART 3 EXECUTION**

## **3.1 BACKFILL**

- A. Place 12 inches of free draining granular backfill borrow under junction boxes for drainage.
- B. Hand tamp sand and untreated base course or approved native soil around the junction box. Match the top 6 inches to the composition, density and elevation of the surrounding surface.

## **3.2 JUNCTION BOX**

- A. Install according to manufacturer's recommendations.
- B. Precast junction boxes with precast conduit holes or drill holes to match conduit entry where required without damaging the box.
  - 1. Make drilled holes in junction box not more than ¼-inch larger than the conduit diameter. Use grout to fill any large gap around conduits or unused entry holes. Finish grout smooth and flush with the interior wall.
- C. Level the top of junction box and grade accordingly.
- D. Field-locate junction boxes to avoid steep slopes and low lying locations with poor drainage.

- E. Do not install junction boxes within the traveled way.
- F. Conduit in junction box:
  - 1. Do not install conduit within 2 inches of junction box corner.
  - 2. Extend conduits a minimum of 6 inches beyond the inside wall of the junction box.
  - 3. Enter conduit through the sides of the junction box and not from the bottom.
  - 4. Place the conduit in the bottom half of the junction box wall at least 3 inches above the floor.
  - 5. Refer to the Standard Drawings.
- G. Install City-approved ½-inch preformed expansion joint material around entire periphery of ring for junction boxes installed in paved surfaces. Refer to the Standard Drawings.
- H. Maximum spacing between junction boxes – 2,500 feet.
- I. Install junction box for underground cable storage beneath electrical equipment cabinet.

### **3.3 PEDESTAL**

- A. Install according to manufacturer's recommendations.
- B. Install within public utility easement at property boundary and near existing utility companies' pedestal location.

### **3.4 GROUND ROD**

- A. Install ground rod to extend a minimum of 4 inches and a maximum of 6 inches above junction box floor.
- B. Attach splice case to the ground rod with a ground wire when cable is armored.

### **3.5 LABELING**

- A. Label all fiber optic cables at each junction box, pedestal, splice case and aerial pole location. See Section 3 for requirements.

### **3.6 RESTORATION**

- A. Restore all areas damaged during the installation of the junction boxes at no additional cost to the City.

END OF SECTION

## SECTION 3

# COMMUNICATIONS CABLING AND TESTING

### PART 1 GENERAL

#### 1.1 SECTION INCLUDES

- A. Materials and procedures for installing and testing fiber optic communication systems.
- B. Materials and procedures for installing and testing electrical power systems.

#### 1.2 RELATED SECTIONS

- A. Section 1: Aerial and Underground Infrastructure
- B. Section 2: Junction Box and Pedestal

#### 1.3 REFERENCES

- A. Electronic Industries Association (EIA) and Telecommunications Industry Association (TIA) Specifications
- B. National Electrical Code (NEC)
- C. National Electric Safety Code (NESC)
- D. Telcordia Guidance
- E. Underwriters Laboratory (UL)
- F. USDA Rural Utilities Service (RUS)

#### 1.4 SUBMITTALS

- A. Submit manufacturer documentation to the City for all Contractor provided equipment and materials for acceptance prior to installation.
- B. Qualified fiber optic technician resume and certificate, furnishing evidence of training and experience for all fiber optic staff including but not limited to: installation technicians, splice technicians and test technicians before any work begins.
  - 1. Include in the file for each technician the following:



- a. Resume listing relevant education and experience.
  - b. Work experience showing a total of at least two years.
  - c. Certificate of completion for an industry accredited fiber optic training course.
- C. Required pre-construction submittal:
- 1. Factory test results showing the attenuation of each cable fiber in dB/km measured at 1310 nm and 1550 nm.
  - 2. Fiber optic cable reel test using Optical Time Domain Reflectometer (OTDR). See Part 3 below.
- D. Required post construction, final submittal:
- 1. OTDR Test Results:
    - a. Hard copy printed and bound test results.
    - b. Current OTDR calibration certificate.
    - c. Electronic submittal of test results per City requirements.
  - 2. Power meter/light source test results:
    - a. Hard copy printed and bound test results.
    - b. Electronic submittal of test results per City requirements.
  - 3. Redline as-built construction plans.

## **1.5 SPLICE DETAILS**

- A. Request project splice details from the City at least 14 days prior to splicing.

## **PART 2 PRODUCTS**

### **2.1 GENERAL**

- A. Provide materials that are UL listed.
- B. Provide all incidental materials including but not limited to fiber optic jumpers, cable ties, labels, tie wraps, connectors and consumables.
- C. Outside Plant materials meet Fluid Penetration Test standards (TIA/EIA-455-82B).
- D. Provide and install all cable in continuous lengths. Splicing or cutting the fiber cable is strictly forbidden except where called for explicitly in the splice details.
- E. Splice and terminate all fibers in the fiber optic cable as indicated on the splice details and as specified herein.

F. Provide all optical glass from the same approved manufacturer.

## 2.2 FIBER OPTIC CABLE

- A. Approved for use by the Rural Utilities Service (RUS).
- B. Outside plant (OSP) type, loose tube, gel filled or gel free, all-dielectric, single-mode fiber optic cable. Refer to cable call outs in the plans.
- C. Use cable with individual buffer tubes and individual fiber strands color coded in compliance with EIA/TIA-598.
- D. Optical fiber:

Table 1

| <b>Fiber Optic Glass<br/>Optical Fiber Specifications</b> |  |
|---|--|
| <b>PARAMETERS</b>   | <b>SINGLE MODE</b>   |
| <b>Type</b>   | <b>Step Index</b>  |
| Core Diameter   | 8.2 $\mu\text{m}$ (Nominal)                                  |
| Cladding Diameter   | 125 $\mu\text{m} \pm .7 \mu\text{m}$                         |
| Core to Cladding Offset                                   | $\leq 0.8 \mu\text{m}$                                       |
| Coating Diameter (OSP)                                    | 245 $\mu\text{m} \pm 5 \mu\text{m}$                          |
| Coating Diameter (IP)                                     | 900 $\mu\text{m} \pm 15 \mu\text{m}$                         |
| Cladding Non-circularity                                  | $\leq .7\%$  |
| Proof Tensile Test  | 100 kpsi (0.7 GN/m <sup>2</sup> )                            |
| <b>Attenuation</b>  |  |
| @ 850nm(MM)   | N/A  |
| @ 1300nm(MM)  | N/A  |
| @ 1310nm(SM)  | $\leq 0.40 \text{ dB/km}$                                    |
| @ 1550nm(SM)  | $\leq 0.30 \text{ dB/km}$                                    |
| <b>Bandwidth</b>  |  |
| @ 850nm(MM)   | N/A  |
| @ 1300nm(MM)  | N/A  |
| <b>Chromatic Dispersion</b>                               |  |
| Zero Dispersion   | 1301.5/1321.5 nm   |
| <b>Wavelength Zero</b>                                    |  |
| Dispersion Slope  | $\leq 0.092 \text{ ps}/(\text{nm}^2 \cdot \text{km})$        |
| Maximum Dispersion  | 3.3 ps/(nm·km) for 1285-1330nm<br>< 18 ps/(nm·km) for 1550nm |
| Cut-Off Wavelength  | 1260 nm  |
| <b>Numerical Aperture</b>                                 |  |
| (EIA-455-47)  | N/A  |

E. Outer Jacket Labeling

1. Date of manufacture and the manufacturer's name.
  2. A numerical footage length stamped at intervals no greater than 10 feet.
- F. Label all fiber optic cables at each junction box, pedestal, splice case and aerial pole location.
1. Junction box, pedestal and splice case locations:
    - a. Text – "MCN Fiber Optic".
    - b. Color – Yellow.
    - c. Print label with circuit I.D. according to City records.
    - d. Flat style label.
  2. Aerial pole locations:
    - a. Text – "MCN Fiber Optic".
    - b. Color – Yellow.
    - c. Wrap-around style label.

## **2.3 FIBER OPTIC CABLE SPLICE CASE**

- A. Provide splice cases with the following minimum characteristics:
1. Complies with Telcordia GR-771.
  2. Corrosion resistant shell.
  3. Allows re-entry without replacing the cable seals.
  4. Strength member tie-off.
  5. Mechanism to resist cable pull-out.
  6. Includes all required accessories to complete the splice.
  7. Compatible with splice module/splitter trays.
  8. Aerial strand hanger kit and pole/wall mount kit where required.
  9. Refer to the Appendix for detailed product requirements.

## **2.4 SPLICE CASE FIBER DETAILS**

- A. Provide a minimum of 3 feet of buffer tube slack from end plate.
- B. Provide 3 to 4 feet of fiber optic strands outside of buffer tube from each cable before splicing.

# **PART 3 EXECUTION**

## **3.1 FIBER OPTIC CABLE INSTALLATION REQUIREMENTS**

- A. Do not perform fiber splices not shown in the City's splice details, project plans or without prior City approval.
- B. Splice all lateral cabling to the main fiber run with a mid-span entry into the cable unless specified differently by the City.

- C. Contact the City a minimum of five business days in advance of installing fiber optic cable into any existing conduit, site or building facility, or any testing required to be witnessed by City fiber inspector.
- D. Request fiber optic test sheets from the City at least 14 days prior to testing.
- E. Fully restore contractor caused damage or breaks to in-use project fiber cable and its conduit within 24 hours of damage. Repair damage to project fiber cable or its conduit that is not in use within 48 hours of damage detection to prevent impacting the project schedule.
- F. Lubricate cable with a lubricant designed for fiber optic cable installation.
- G. Use shear pins or other failsafe means to prevent exceeding the maximum cable pulling tension as rated by the cable manufacturer.
- H. Maintain the following minimum bend radii:
  - 1. 20 times cable diameter during installation.
  - 2. 10 times cable diameter following installation.
- I. Cable slack requirements:
  - 1. Store excess cable slack at designated intervals, including at each junction box, aerial slack location and aerial splice point. Note that the slack is to be equally distributed on either side of the splice case at a splice location.
 

|    |   |          |
|----|---|----------|
| a. | Junction box (end of reel)                    | 50 feet  |
| b. | Junction box                                  | 100 feet |
| c. | Aerial slack                                  | 150 feet |
| d. | Aerial splice (or as needed for higher spans) | 150 feet |
| e. | Pedestal                                      | 20 feet  |
  - 2. Provide proper storage of slack cable, both long term and short term. Neatly bind cables to be spliced together from conduit to splice case with tape.
- J. Replace any fiber optic cable segment that does not meet the specification requirements in its entirety between full splice points.

### **3.2 FIBER OPTIC CABLE PREPARATION**

- A. Solvent requirements:
  - 1. Must not remove any color from individual fibers. Refer to TIA/EIA-598-A or buffer tubes.
  - 2. Not harmful to the polyethylene cable jacket.

### **3.3 ENTRY AND REENTRY OF FIBER OPTIC SPLICE CASES**

- A. Perform all work in an environmentally controlled atmosphere.
  - 1. Acceptable environments include office type environments in buildings, splice trailers and splicing tents with floors.
  - 2. Do not splice, test, connect or open fiber ends in locations with freezing temperatures, rain, snow, or wind-blown dust.
  - 3. Verify connectivity of all working fiber.

### **3.4 FUSION SPLICING**

- A. Use fusion splice method for all fiber splicing.
- B. Perform fusion splices as follows:
  - 1. Use equipment with automatic fiber alignment and automatic light injection with detection devices or profile alignment algorithms to estimate splice losses.
  - 2. Provide splice case as a protection for all splices and stripped cable.
  - 3. House all splices in splice trays or organizers.
  - 4. Use heat shrink tubing to provide additional protection and strain relief of each fusion splice.
  - 5. Comply with maximum splice loss allowance of 0.03 dB as measured with a fusion splicing machine.

### **3.5 ACCEPTANCE TESTING**

- A. Fiber optic cable reel test:
  - 1. Test the fiber optic cable at the site storage area before installation.
  - 2. Test each optical fiber in all buffer tubes unidirectionally using an OTDR.
  - 3. Conduct all traces at both 1310 nm and 1550 nm wavelengths for continuity, length, anomalies and approximate attenuation.
  - 4. Record each measurement with color, location and type of fiber measured.
  - 5. Conduct all traces with a minimum 1 km launch cable/test box between the OTDR and the fiber under test.
  - 6. Submit results to the City for approval prior to cable installation.
- B. Post installation test:
  - 1. Contact the City a minimum of five business days before performing testing to schedule inspection.
  - 2. Perform all fiber optic testing with an OTDR capable of producing output files that are compatible with City OTDR software or furnish at no cost to the City, the software necessary for viewing the OTDR data.

3. OTDR testing requirements:
  - a. Test every fiber strand of each cable installed.
  - b. Conduct all traces with a minimum 1 km launch cable/test box between the OTDR and the fiber under test.
  - c. Do not exceed insertion loss 1.0 dB.
  - d. Conduct all traces at both 1310 nm and 1550 nm wavelengths, and bidirectionally.
  - e. Tabulate for each trace: method, fiber type, wavelength, pulse width, refractive index, range, search threshold, reflection threshold, end threshold, warning threshold, backscatter, jumper length, file date, file time, fiber ID, cable ID, OTDR location, far end location, and operator initials.
  - f. Provide an event table showing all events with more than 0.03 dB loss containing event type, position from OTDR end, loss, and reflectance.
  - g. Identify fibers by strand number.
  - h. Submit all test results to the City in electronic form. Provide PDF copies of all trace files, as well as the OTDR generated trace files.
  - i. Cable to be tested by certified staff.
  - j. City inspector witnesses and approves before final approval by the City.
4. Post termination test acceptance criteria:
  - a. Cable attenuation 0.4 dB/km at 1310 nm, excluding splices described in the contract or authorized by the City.
  - b. Cable attenuation 0.30 dB/km at 1550 nm, excluding splices described in the contract or authorized by the City.
  - c. Strand lengths are consistent.
  - d. Insertion loss < 1.0 dB.
  - e. No event > 0.30 dB.
  - f. Trace produced for each strand in all cable segments.
  - g. Adhere to optical splitter manufacturer's requirements and thresholds when testing through any PON splitter.
5. Power meter/light source test:
  - a. Conduct power meter/light source testing at both 1310 nm and 1550 nm wavelengths, and bidirectionally.
  - b. Test every field location required to obtain access to each cable segment.
  - c. Perform all testing using two qualified fiber optic technicians and two vehicles.
  - d. A City inspector witnesses and approves the results before final approval by the City.
  - e. Acceptance Criteria:
    - 1) Cable attenuation meets link-loss budget for each strand segment.

- 2) Test is available for each strand in each cable segment.
- f. Submit all test results with the OTDR traces in electronic format, both in PDF and power meter generated files, if applicable.

END OF SECTION

**NOTES:**

1. CONFORM TO ALL ROCKY MOUNTAIN POWER AND NESC REQUIREMENTS.
2. ATTACH TO POLES ON THE SAME SIDE AS EXISTING ATTACHMENTS.
3. INSTALL SLACK-SPAN SEGMENTS WHERE EXISTING ATTACHMENTS ARE SLACK-SPANS.
4. PROVIDE A MINIMUM OF 8 FT SPACING BETWEEN AT LEAST ONE SET OF THE STAND OFF BRACKETS, INCLUDING ALL EXISTING RISER STAND OFF BRACKETS, TO PREVENT CLIMBING PER THE NESC REQUIREMENTS.
5. USE STANDARD 5/8" GALVANIZED HARDWARE.

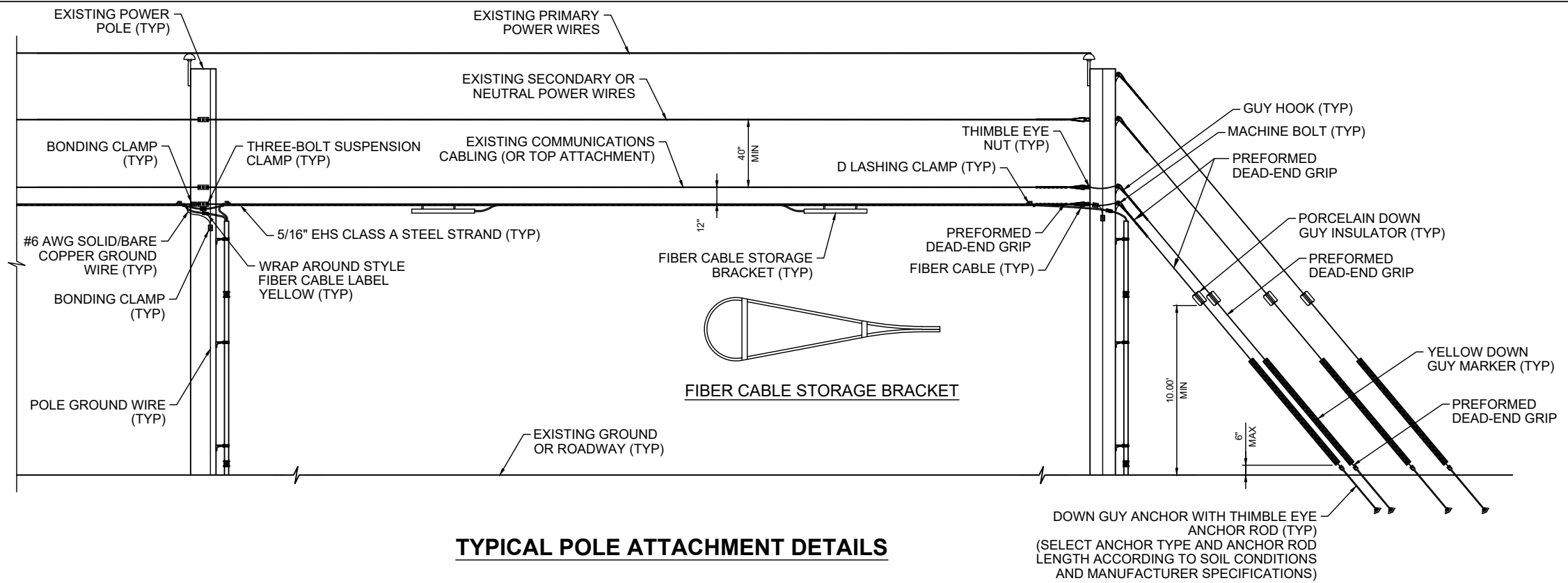

**TYPICAL POLE ATTACHMENT DETAILS**

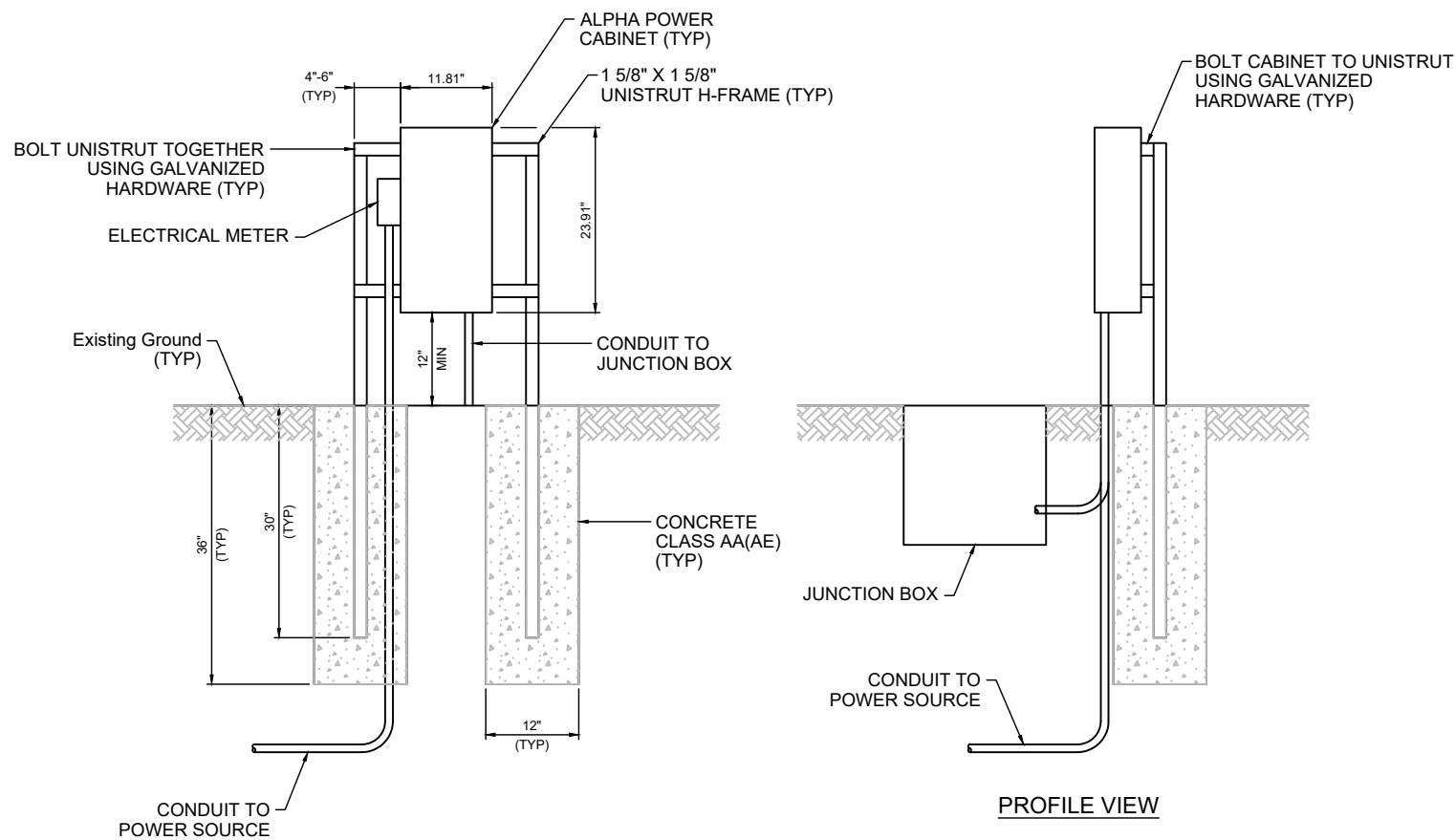

**ALPHA CABINET DETAIL**

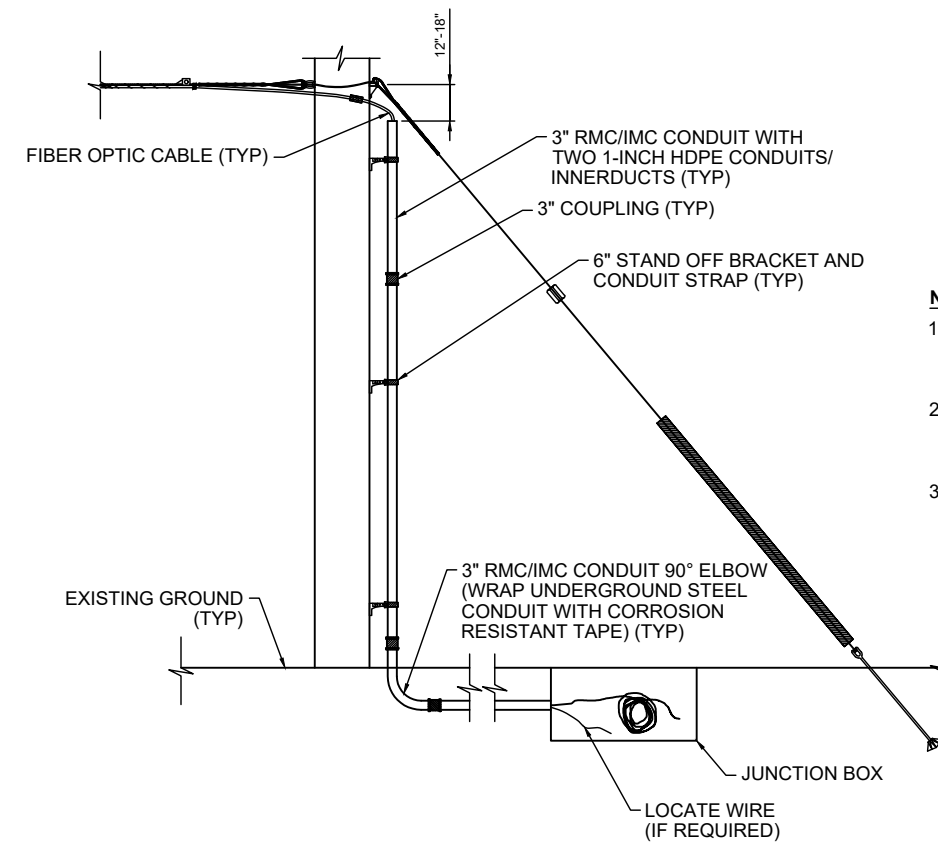

**RISER CONDUIT DETAIL**

**NOTES:**

1. INSTALL RISER CONDUITS ON FACE POLE OPPOSITE OF TRAFFIC. ADJUST IN FIELD AS NECESSARY.
2. SEAL TOP OF RISER CONDUITS USING DUCT SEAL OR OTHER APPROVED METHODS TO PREVENT WATER MIGRATION.
3. PROVIDE A MINIMUM OF 8 FT SPACING BETWEEN AT LEAST ONE SET OF THE STAND OFF BRACKETS, INCLUDING ALL EXISTING RISER STAND OFF BRACKETS, TO PREVENT CLIMBING PER THE NESC REQUIREMENTS.

C:\Users\jeff.bone\OneDrive - Horrocks Engineers\Desktop\Mapleton City\Mapleton City Conduit Installation Details.dwg  
JEFF.BONE  
08/05/2022 8:39 AM

| REV | DATE | BY | DESCRIPTION |
|-----|------|----|-------------|
|     |      |    |             |
|     |      |    |             |
|     |      |    |             |
|     |      |    |             |



1405 West 1600 North  
Mapleton, UT 84664  
(801) 489-6253

**MAPLETON CITY**  
AERIAL, RISER AND ALPHA CABINET DETAILS

DATE 10/01/2021

DRAWING NO.

**SD-01**



08/05/2022 8:39 AM C:\Users\jeff.bone\OneDrive - Horrocks Engineers\Desktop\Mapleton City\Mapleton City Conduit Installation Details.dwg JEFF.BONE

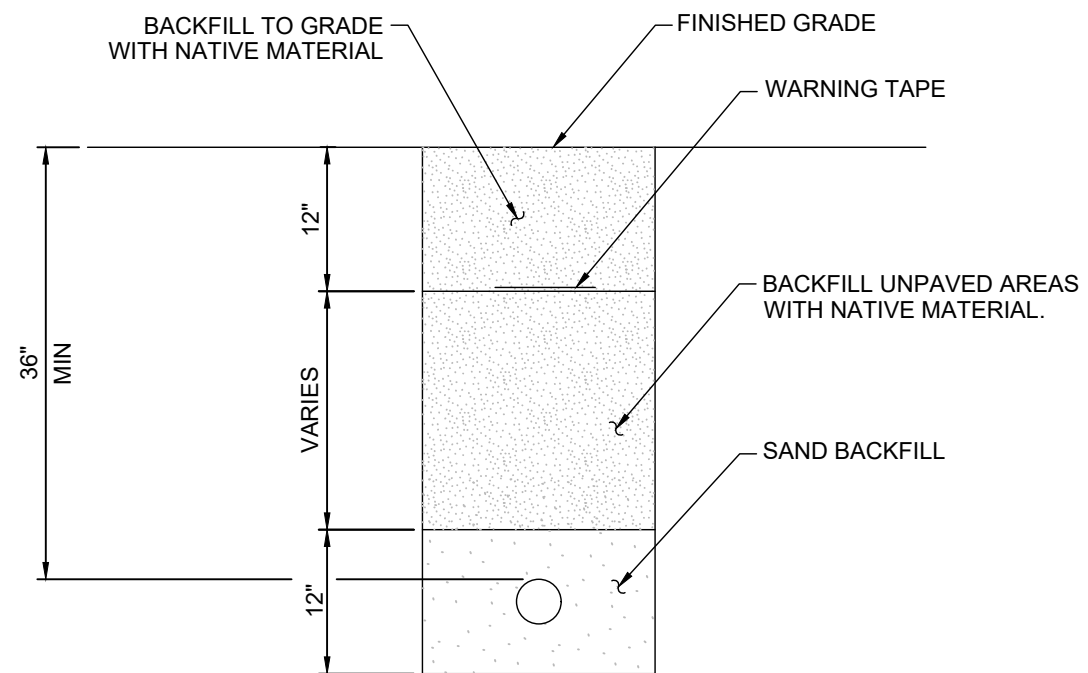

**UNPAVED AREAS**

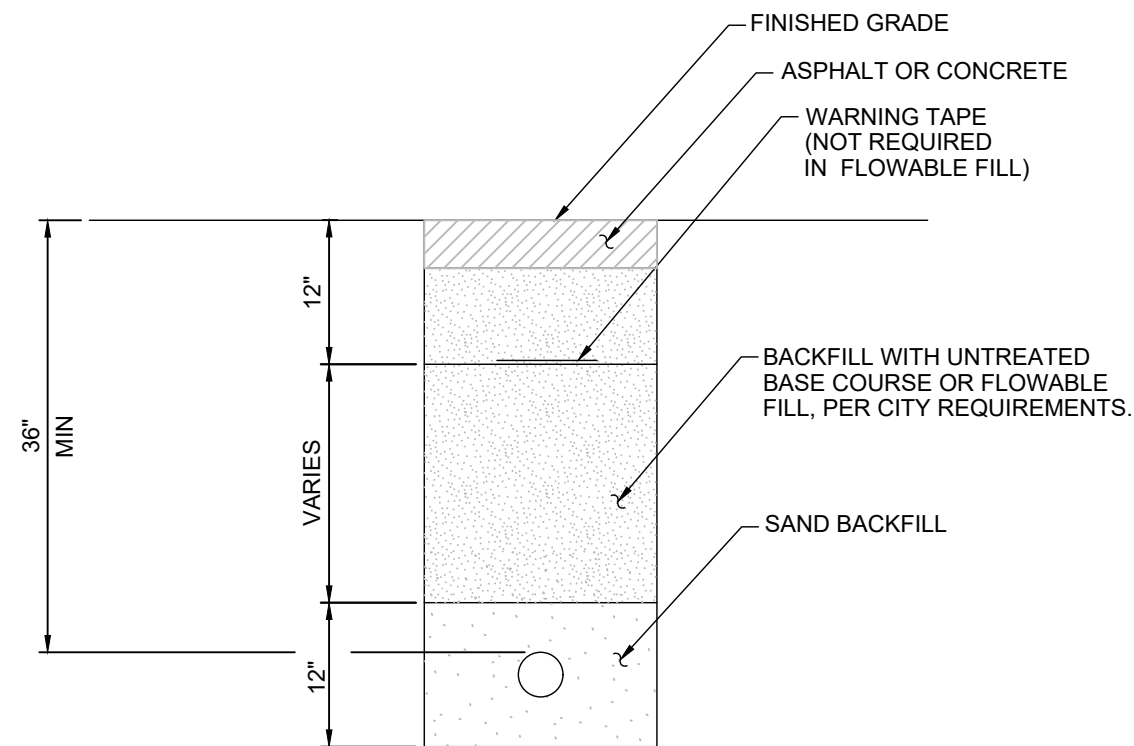

**PAVED / SIDEWALK AREAS**

**NOTES:**

1. SAW CUT PAVEMENT EDGES. APPLY A HOT-POUR RUBBERIZED ASHALT JOINT SEALANT OR APPROVED EQUAL. APPLIED AFTER PATCH IS INSTALLED.
2. USE HMA MATERIAL FOR T-PATCH.
3. EVENLY APPLY TACK COAT ON FINAL BACKFILL BEFORE INSTALLING T-PATCH.
4. COMPACT ALL BACKFILL PER CITY REQUIREMENTS.

| REV | DATE | BY | DESCRIPTION |
|-----|------|----|-------------|
|     |      |    |             |
|     |      |    |             |
|     |      |    |             |
|     |      |    |             |



1405 West 1600 North  
 Mapleton, UT 84664  
 (801) 489-6253

**MAPLETON CITY**

TRENCHING DETAILS

DATE 10/01/2021

DRAWING NO.

**SD-02**

08/05/2022 8:39 AM C:\Users\jeff.bone\OneDrive - Horrocks Engineers\Desktop\Mapleton City\Mapleton City Conduit Installation Details.dwg JEFF.BONE

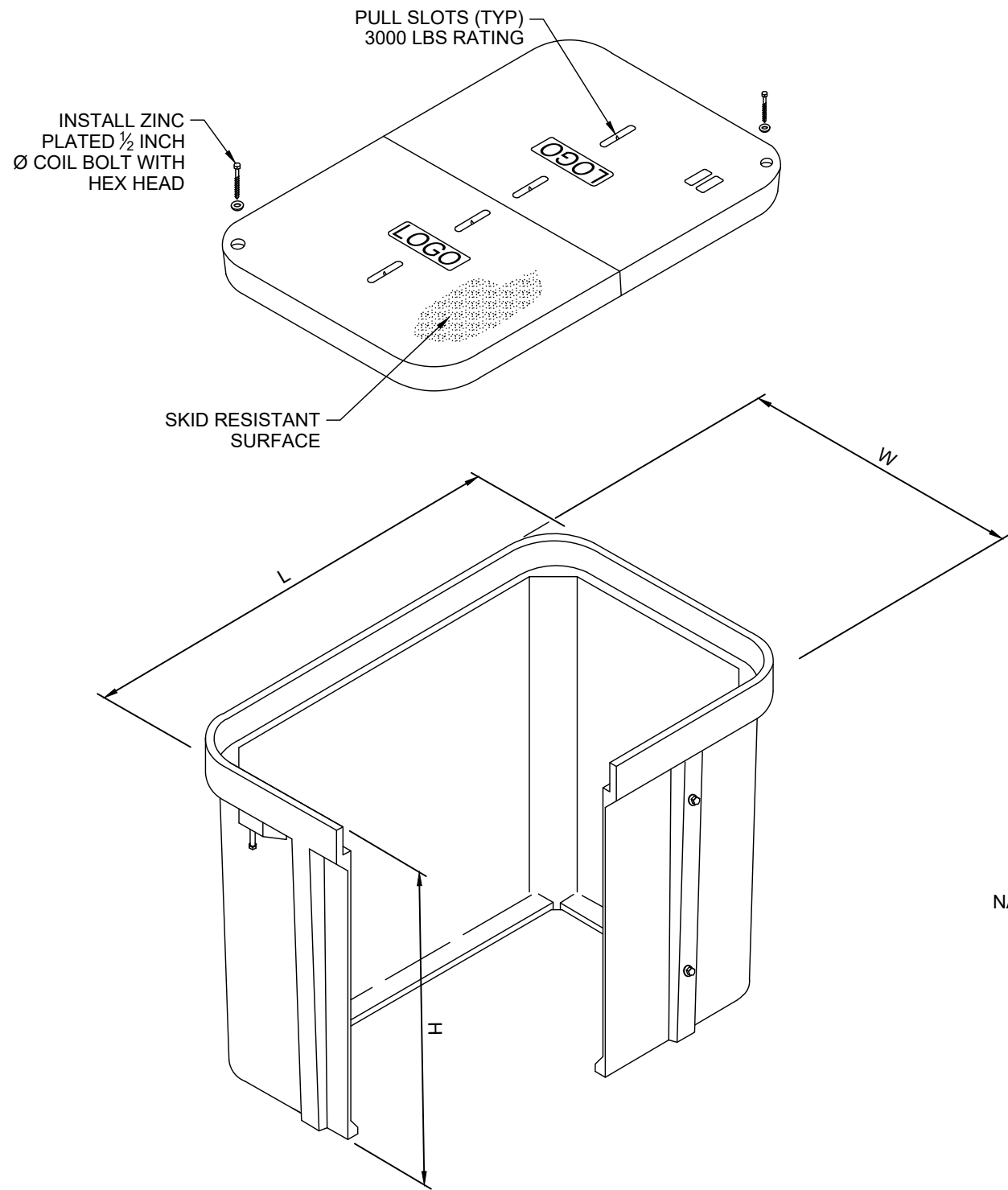

**TABLE OF DIMENSIONS (NOMINAL)**

| APPLICATION       | "W" INCH | "L" INCH | "H" INCH | LOADING |
|-------------------|----------|----------|----------|---------|
| CABINET LOCATION  | 17       | 30       | 24       | TIER 22 |
| PULL BOX / SPLICE | 24       | 36       | 24       | TIER 22 |

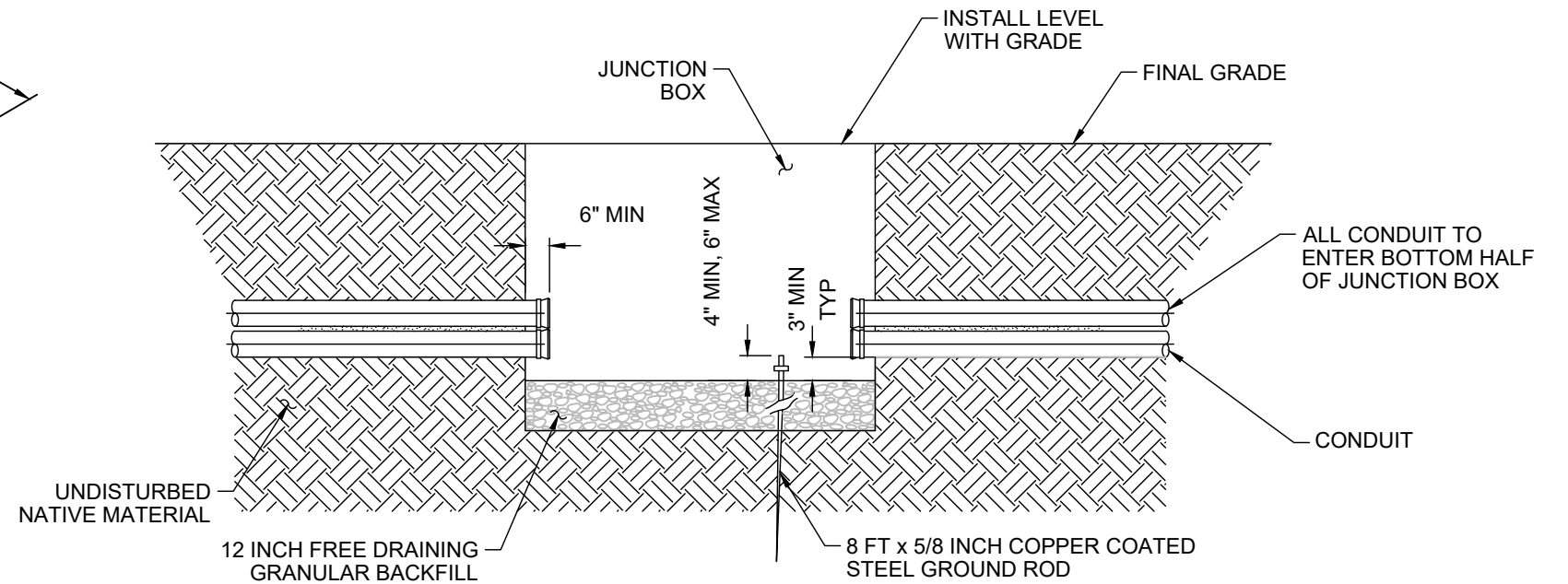

**NOTES:**

1. BOX LOGO OR NAME PLATE, REFER TO STANDARD SPECIFICATIONS.
2. DO NOT PLACE JUNCTION BOXES IN THE TRAVELED WAY.
3. CONFORM TO ANSI/SCTE-77 "SPECIFICATION FOR UNDERGROUND ENCLOSURE INTEGRITY" TIER 22 LOADING FOR ALL JUNCTION BOXES. TIER 22 ID PLATE TO BE VISIBLE ON BOX.
4. DO NOT CUT GROUND RODS.
5. PROVIDE CLEAR SPACE OF AT LEAST 36 INCH FOR PERSONNEL TO PULL LID OFF BOX WITHOUT CONFLICT.
6. REFER TO THE APPENDIX FOR DETAILED PRODUCT REQUIREMENTS.

| REV       | DATE | BY | DESCRIPTION |
|-----------|------|----|-------------|
| REVISIONS |      |    |             |



1405 West 1600 North  
Mapleton, UT 84664  
(801) 489-6253

**MAPLETON CITY**

JUNCTION BOX DETAILS

DATE 10/01/2021

DRAWING NO.

**SD-03**

08/05/2022 8:39 AM C:\Users\jeff.bone\OneDrive - Horrocks Engineers\Desktop\Mapleton City\Mapleton City Conduit Installation Details.dwg JEFF.BONE

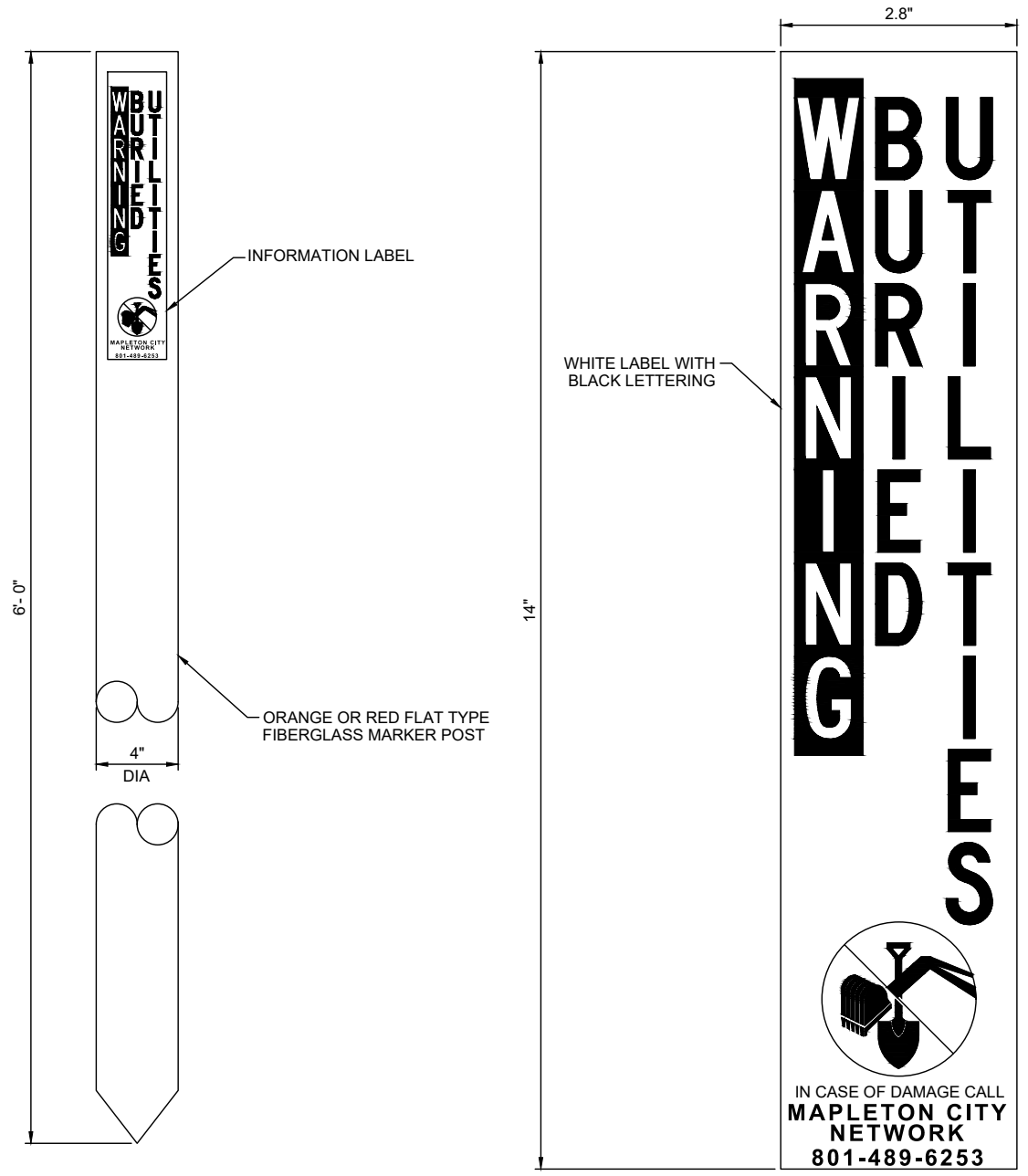

**UTILITY MARKER POST - FLAT TYPE**

**INFORMATION LABEL**

**NOTES:**

1. PROVIDE FIBERGLASS MARKER POSTS THAT ARE 4 INCH WIDE BY 6 FT TALL, WITH 4 FT EXPOSED AFTER INSTALLATION.
2. PROVIDE MARKER POSTS THAT ARE ORANGE IN COLOR WHEN THE JUNCTION BOX/CONDUIT SYSTEM CONTAINS COMMUNICATION CABLE.
3. PROVIDE MARKER POSTS THAT ARE RED IN COLOR WHEN THE JUNCTION BOX/CONDUIT SYSTEM CONTAINS POWER CABLE.
4. DUPLICATE MARKER POSTS ARE NOT REQUIRED ON PARALLEL CONDUIT RUNS.
5. PLACE LOGO STICKERS ON MARKER POST 3 INCHES FROM TOP.

| REV | DATE | BY | DESCRIPTION |
|-----|------|----|-------------|
|     |      |    |             |
|     |      |    |             |
|     |      |    |             |
|     |      |    |             |
|     |      |    |             |



1405 West 1600 North  
Mapleton, UT 84664  
(801) 489-6253

**MAPLETON CITY**

MARKER POST DETAILS

|             |            |
|-------------|------------|
| DATE        | 10/01/2021 |
| DRAWING NO. | SD-04      |

08/05/2022 8:39 AM C:\Users\jeff.bone\OneDrive - Horrocks Engineers\Desktop\Mapleton City\Mapleton City Conduit Installation Details.dwg JEFF.BONE

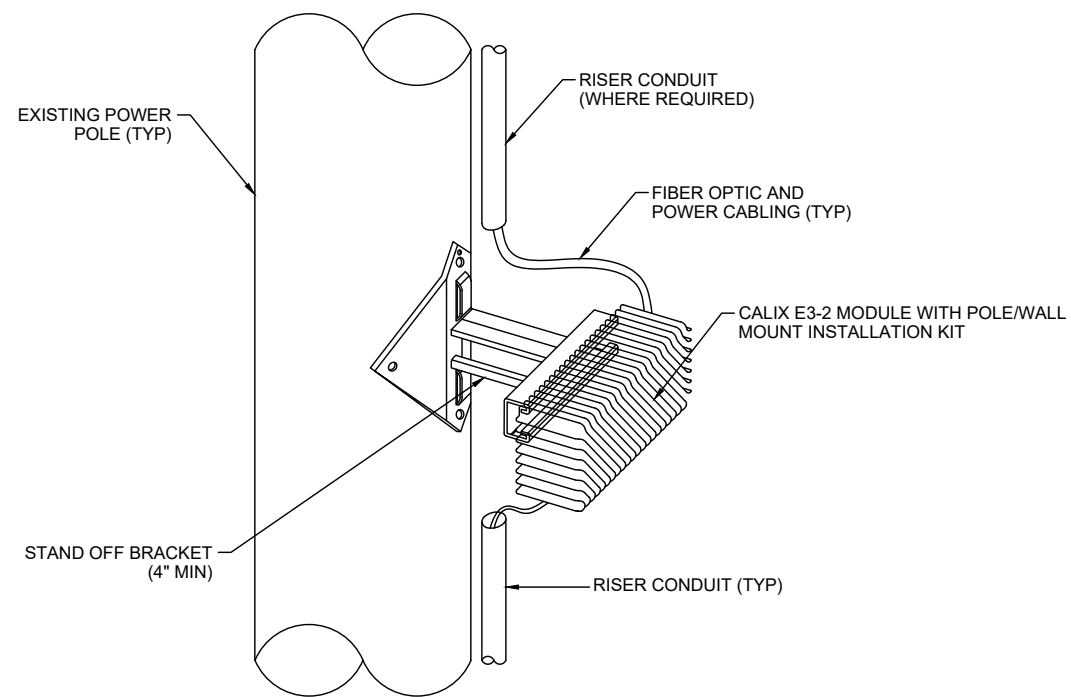

**POLE MOUNT MODULE**

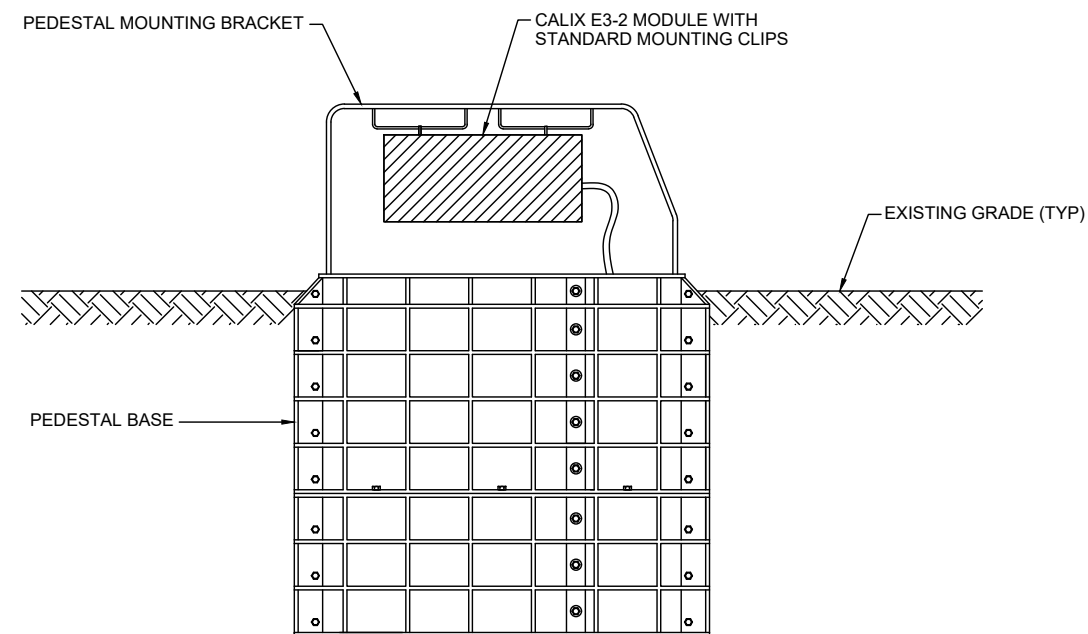

**PEDESTAL MOUNT MODULE**

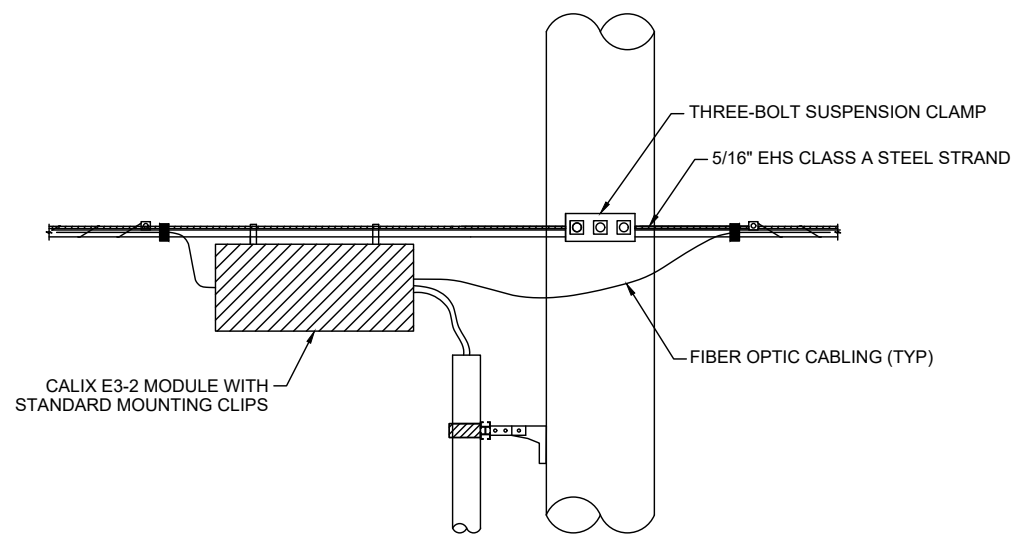

**STRAND MOUNT MODULE**



1405 West 1600 North  
 Mapleton, UT 84664  
 (801) 489-6253

**MAPLETON CITY**

CALIX E3-2 MODULE MOUNTING DETAILS

DATE 10/01/2021

DRAWING NO.

**SD-05**

| REV | DATE | BY | DESCRIPTION |
|-----|------|----|-------------|
|     |      |    |             |
|     |      |    |             |
|     |      |    |             |
|     |      |    |             |
|     |      |    |             |

08/05/2022 8:39 AM C:\Users\jeff.bone\OneDrive - Horrocks Engineers\Desktop\Mapleton City\Mapleton City Conduit Installation Details.dwg JEFF.BONE

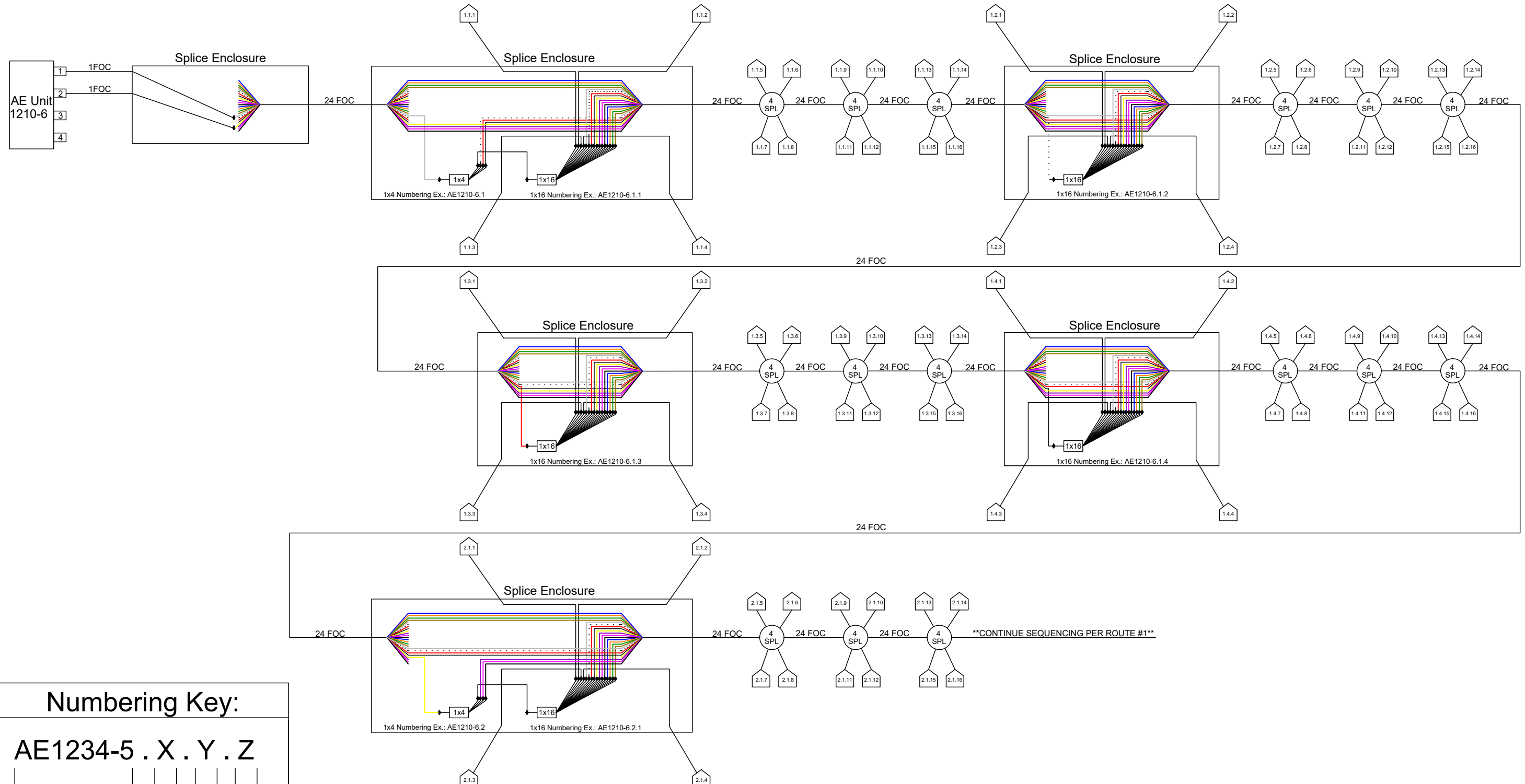

**Numbering Key:**

**AE1234-5 . X . Y . Z**

|                       |  |                       |                              |               |
|-----------------------|--|-----------------------|------------------------------|---------------|
|                       |  |                       |                              |               |
| AE Unit/Circuit Point |  | 1x16 Splitter (# 1-4) | AE Port/1x4 Splitter (# 1-4) | Drop (# 1-16) |



1405 West 1600 North  
Mapleton, UT 84664  
(801) 489-6253

**MAPLETON CITY**  
TYPICAL PON SPLITTING & FUSION SPLICE DETAILS

|             |            |
|-------------|------------|
| DATE        | 08/05/2022 |
| DRAWING NO. | SD-06      |

| REV | DATE | BY | DESCRIPTION |
|-----|------|----|-------------|
|     |      |    |             |
|     |      |    |             |
|     |      |    |             |
|     |      |    |             |

REVISIONS

C:\Users\jeff.bone\OneDrive - Horrocks Engineers\Desktop\Mapleton City\Mapleton City Conduit Installation Details.dwg  
JEFF.BONE  
08/05/2022 8:39 AM

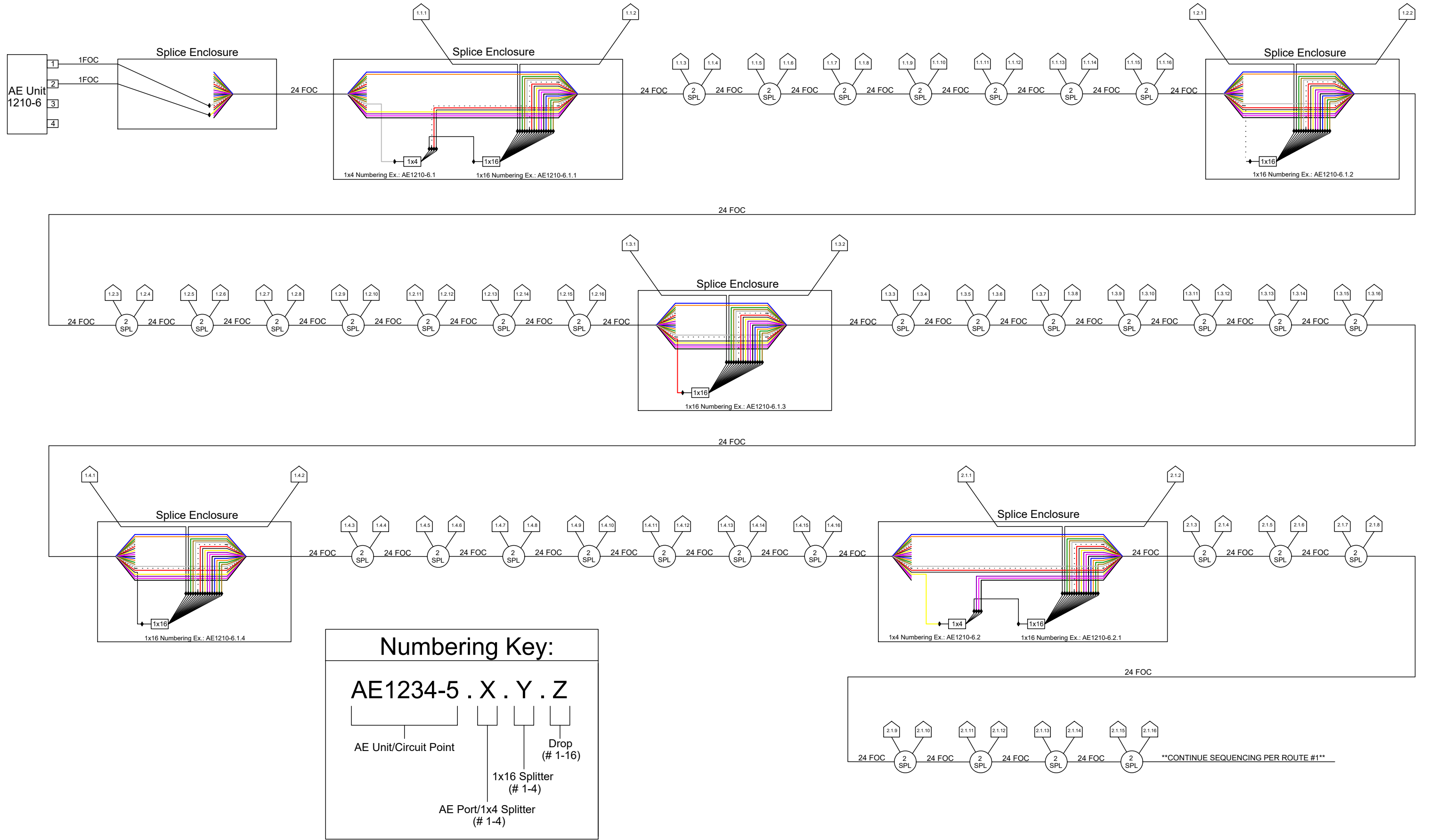

**Numbering Key:**

**AE1234-5 . X . Y . Z**

|                       |                          |                                 |                  |
|-----------------------|--------------------------|---------------------------------|------------------|
|                       |                          |                                 |                  |
| AE Unit/Circuit Point | 1x16 Splitter<br>(# 1-4) | AE Port/1x4 Splitter<br>(# 1-4) | Drop<br>(# 1-16) |



1405 West 1600 North  
Mapleton, UT 84664  
(801) 489-6253

**MAPLETON CITY**  
TYPICAL PON SPLITTING & FUSION SPLICE DETAILS

DATE 08/05/2022

DRAWING NO.

**SD-07**

| REV | DATE | BY | DESCRIPTION |
|-----|------|----|-------------|
|     |      |    |             |
|     |      |    |             |
|     |      |    |             |
|     |      |    |             |
|     |      |    |             |

REVISIONS

C:\Users\jeff.bone\OneDrive - Horrocks Engineers\Desktop\Mapleton City\Mapleton City Conduit Installation Details.dwg

JEFF.BONE  
08/05/2022 8:39 AM

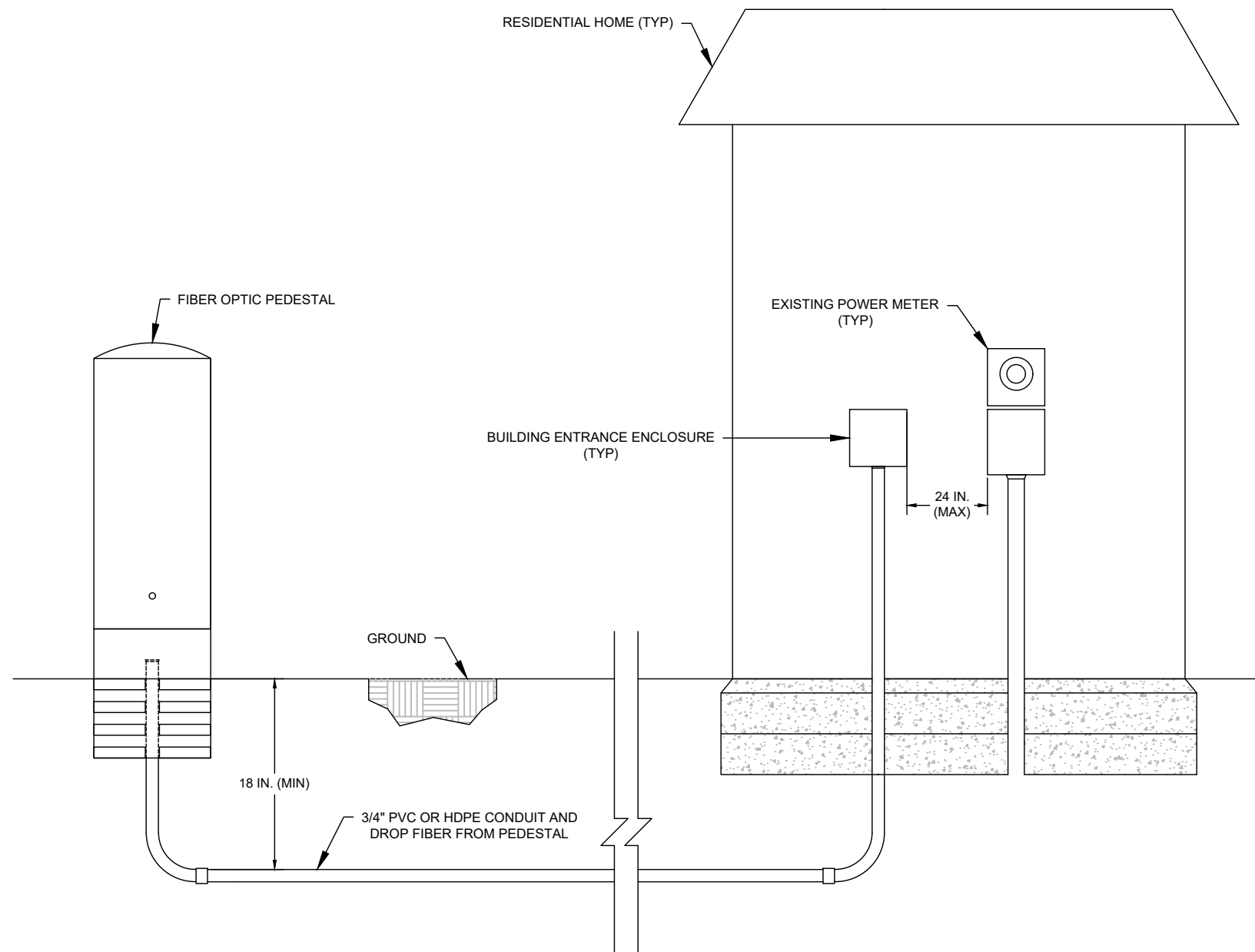

## UNDERGROUND / OUTDOOR - PROFILE VIEW

N.T.S.

**GENERAL NOTES:**

1. TOTAL CONDUIT DEFLECTION BETWEEN PEDESTAL AND ENTRANCE ENCLOSURE IS 270 DEGREES MAX. MAXIMUM OF TWO 90-DEGREE CONDUIT BENDS ALLOWED.
2. TOTAL CONDUIT DEFLECTION BETWEEN PREMISE COMMUNICATION ROOM AND ENTRANCE ENCLOSURE IS 270 DEGREES MAX. MAXIMUM OF TWO 90-DEGREE CONDUIT BENDS ALLOWED.
3. 120-V POWER OUTLET TO BE AVAILABLE IN PREMISE COMMUNICATION ROOM.

| REV | DATE | BY | DESCRIPTION |
|-----|------|----|-------------|
|     |      |    |             |
|     |      |    |             |
|     |      |    |             |
|     |      |    |             |



1405 West 1600 North  
Mapleton, UT 84664  
(801) 489-6253

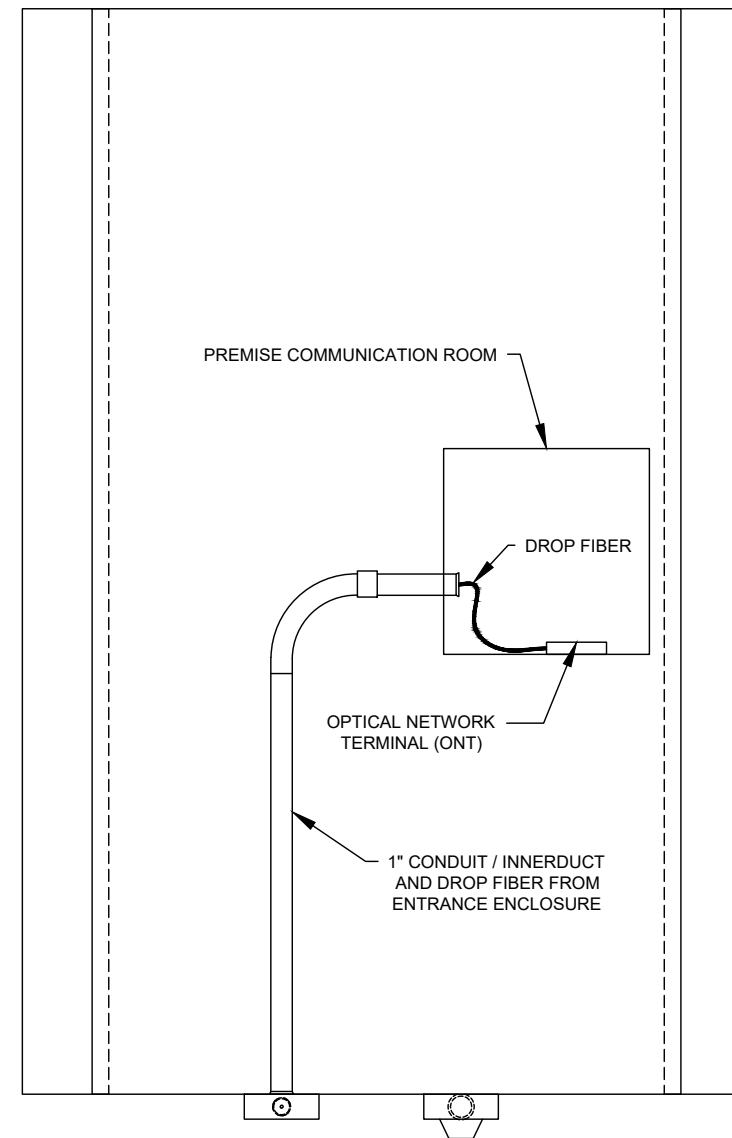

## PREMISE / INDOOR - PLAN VIEW

N.T.S.

**PREMISE INSTALLATION NOTES:**

**MCN Residential Equipment and Installation**

**Point of Service** In consultation with the City Engineer or designee, Mapleton City Network (MCN) will determine the demarcation or points of service for all public developments and for individual service entrances.

**Underground Communication Service Requirements**

1. Customer or developer shall, install all conduit from the building to the communication pole or pedestal according to City standards.
2. Residential: One 1-inch PVC or equivalent conduit shall be run from the premise communication room out to within two feet of the premise power meter. Conduit shall be installed with wide radius 90-degree bends, not to exceed 270-degrees.

**Residential Inside Wiring Recommendations**

**Home Communications Panel.** The following are recommended specifications for a home communication panel.

**Mounting.** The minimum necessary for a communications center would be a simple 2'X2' piece of 1/2" plywood securely attached to the wall in an inside utility area. Manufactured panels are available for a more professional installation.

**Location.** The location of the communication center should be readily accessible. Good areas to consider are garages, utility room, or other dry unfinished areas.

**Electrical Outlet.** A standard electrical outlet is required for the fiber optic network terminal, wireless routers and associated home network equipment.

**Internal Premise Wiring.** CAT6+ cable wiring is optimal and should be considered when wiring your premise for highspeed broadband services.

**MAPLETON CITY**  
RESIDENTIAL CONDUIT INSTALLATION

DATE 08/05/2022

DRAWING NO.

**SD-08**

# PLAN VIEW

N.T.S.

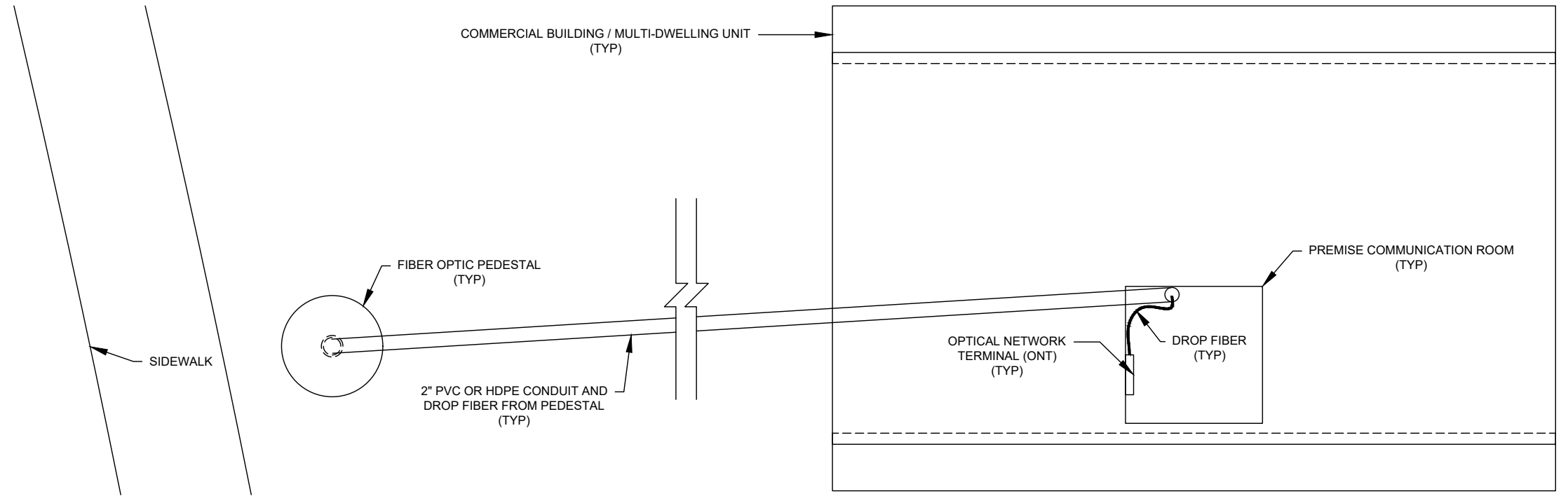

# PROFILE VIEW

N.T.S.

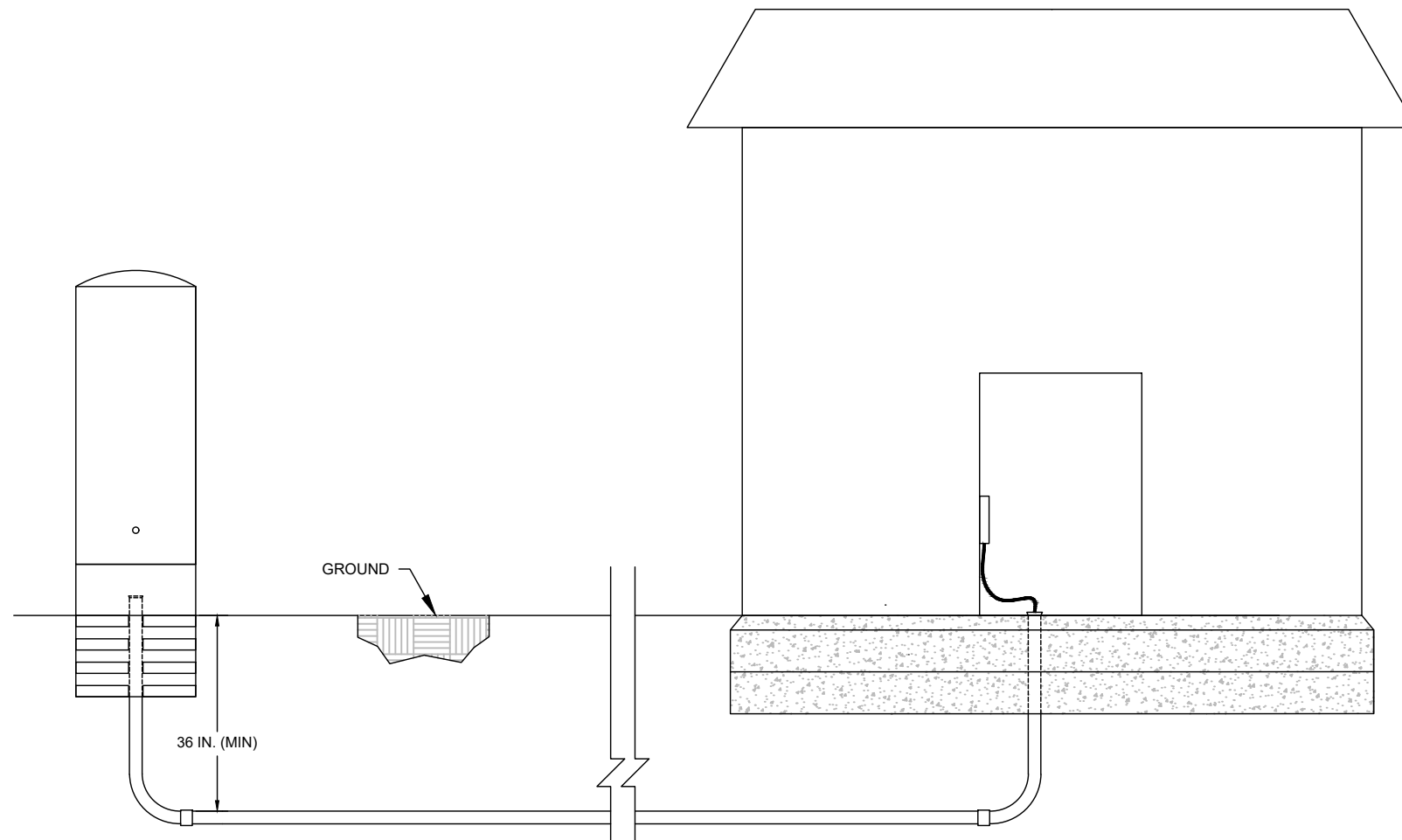

### PREMISE INSTALLATION NOTES:

#### Recommended Commercial Equipment and Installation

**Point of Service** In consultation with the City Engineer or designee, Mapleton City Network (MCN) will determine the demarcation or points of service for all public developments and for individual service entrances.

#### Underground Communication Service Requirements

1. Customer or developer shall, install all conduit from the building to the communication pole or pedestal according to City standards.
2. Commercial: One 2-inch PVC or approved SDR-HDPE conduit shall be run from each unit 4-mark location inside the building directly into the City's communication pedestal. Each conduit shall be installed with wide radius 90-degree bends, not to exceed 270-degrees. All conduit passing through concrete shall be a rigid or Intermediate Metal Conduit (IMC) conduit.

#### Inside Wiring Recommendations

**Location.** The fiber optic communication panel shall be located in an area that is readily accessible for maintenance and service. Good areas to consider are utility rooms, or other dry unfinished locations.

**Electrical Outlet.** A standard electrical outlet is required for the fiber optic network terminal, wireless router and associated network equipment.

**Internal Premise Wiring.** CAT6+ cable wiring is optimal and should be considered when wiring your premise for highspeed broadband services.

- GENERAL NOTES:**
1. TOTAL CONDUIT DEFLECTION BETWEEN PEDESTAL AND PREMISE COMMUNICATION ROOM IS 270 DEGREES MAX. MAXIMUM OF TWO 90-DEGREE CONDUIT BENDS ALLOWED.
  2. ANY CONDUIT PASSING THROUGH CONCRETE SHALL BE RMC / IMC.
  3. 120-V POWER OUTLET TO BE AVAILABLE IN PREMISE COMMUNICATION ROOM.

C:\Users\jeff.bone\OneDrive - Horrocks Engineers\Desktop\Mapleton City\Mapleton City Conduit Installation Details.dwg  
JEFF.BONE  
08/05/2022 8:39 AM

| REV | DATE | BY | DESCRIPTION |
|-----|------|----|-------------|
|     |      |    |             |
|     |      |    |             |
|     |      |    |             |
|     |      |    |             |
|     |      |    |             |



1405 West 1600 North  
Mapleton, UT 84664  
(801) 489-6253

# MAPLETON CITY

COMMERCIAL CONDUIT INSTALLATION - OPTION 1

DATE 08/05/2022

DRAWING NO.

SD-09



C:\Users\jeff.bone\OneDrive - Horrocks Engineers\Desktop\Mapleton City\Mapleton City Conduit Installation Details.dwg  
JEFF.BONE  
8:39 AM  
08/05/2022

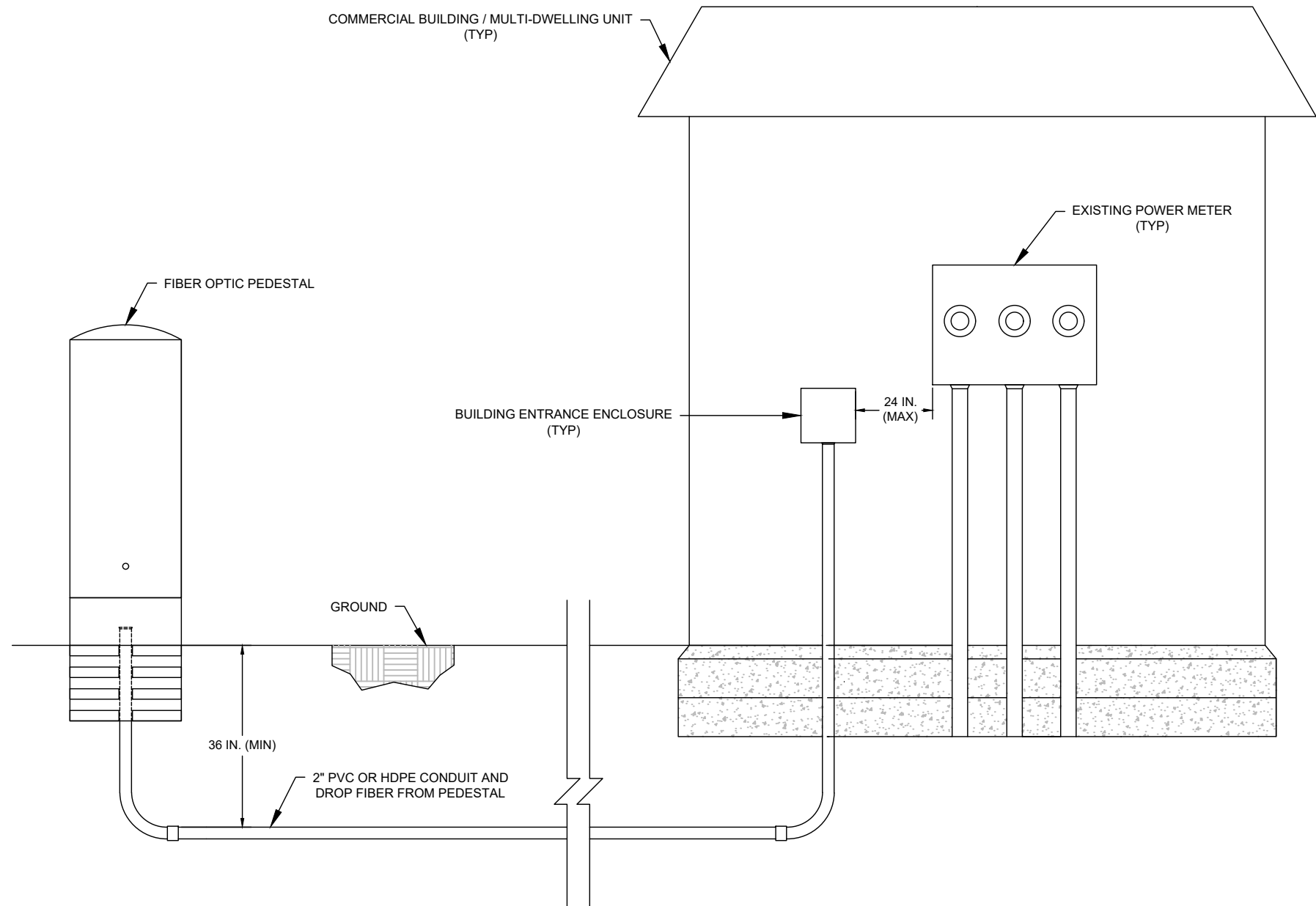

## UNDERGROUND / OUTDOOR - PROFILE VIEW

N.T.S.

**GENERAL NOTES:**

1. TOTAL CONDUIT DEFLECTION BETWEEN PEDESTAL AND ENTRANCE ENCLOSURE IS 270 DEGREES MAX. MAXIMUM OF TWO 90-DEGREE CONDUIT BENDS ALLOWED.
2. TOTAL CONDUIT DEFLECTION BETWEEN PREMISE COMMUNICATION ROOM AND ENTRANCE ENCLOSURE IS 270 DEGREES MAX. MAXIMUM OF TWO 90-DEGREE CONDUIT BENDS ALLOWED.
3. ANY CONDUIT PASSING THROUGH CONCRETE SHALL BE RMC / IMC.
4. 120-V POWER OUTLET TO BE AVAILABLE IN PREMISE COMMUNICATION ROOM.

| REV | DATE | BY | DESCRIPTION |
|-----|------|----|-------------|
|     |      |    |             |
|     |      |    |             |
|     |      |    |             |
|     |      |    |             |



1405 West 1600 North  
Mapleton, UT 84664  
(801) 489-6253

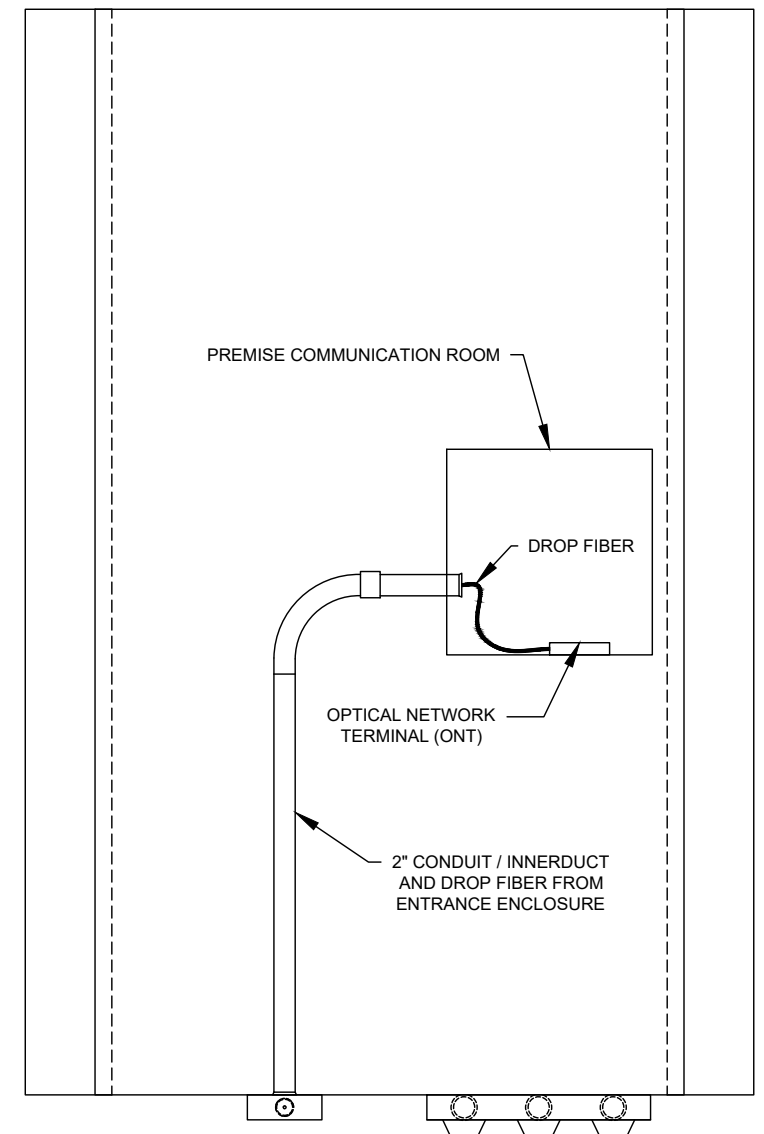

## PREMISE / INDOOR - PLAN VIEW

N.T.S.

**PREMISE INSTALLATION NOTES:**

**Recommended Commercial Equipment and Installation**

**Point of Service** In consultation with the City Engineer or designee, Mapleton City Network (MCN) will determine the demarcation or points of service for all public developments and for individual service entrances.

**Underground Communication Service Requirements**

1. Customer or developer shall, install all conduit from the building to the communication pole or pedestal according to City standards.
2. Commercial: One 2-inch PVC or approved SDR-HDPE conduit shall be run from each unit d-mark location inside the building directly into the City's communication pedestal. Each conduit shall be installed with wide radius 90-degree bends, not to exceed 270-degrees. All conduit passing through concrete shall be a rigid or Intermediate Metal Conduit (IMC) conduit.

**Inside Wiring Recommendations**

**Location.** The fiber optic communication panel shall be located in an area that is readily accessible for maintenance and service. Good areas to consider are utility rooms, or other dry unfinished locations.

**Electrical Outlet.** A standard electrical outlet is required for the fiber optic network terminal, wireless router and associated network equipment.

**Internal Premise Wiring.** CAT6+ cable wiring is optimal and should be considered when wiring your premise for highspeed broadband services.

# MAPLETON CITY

COMMERCIAL CONDUIT INSTALLATION - OPTION 2

DATE 08/05/2022

DRAWING NO.

SD-10

08/12/2022 8:00 AM C:\Users\jeff.bone\OneDrive - Horrocks Engineers\Desktop\Mapleton City\Mapleton City Conduit Installation Details SD-01 to SD-11.dwg JEFF.BONE

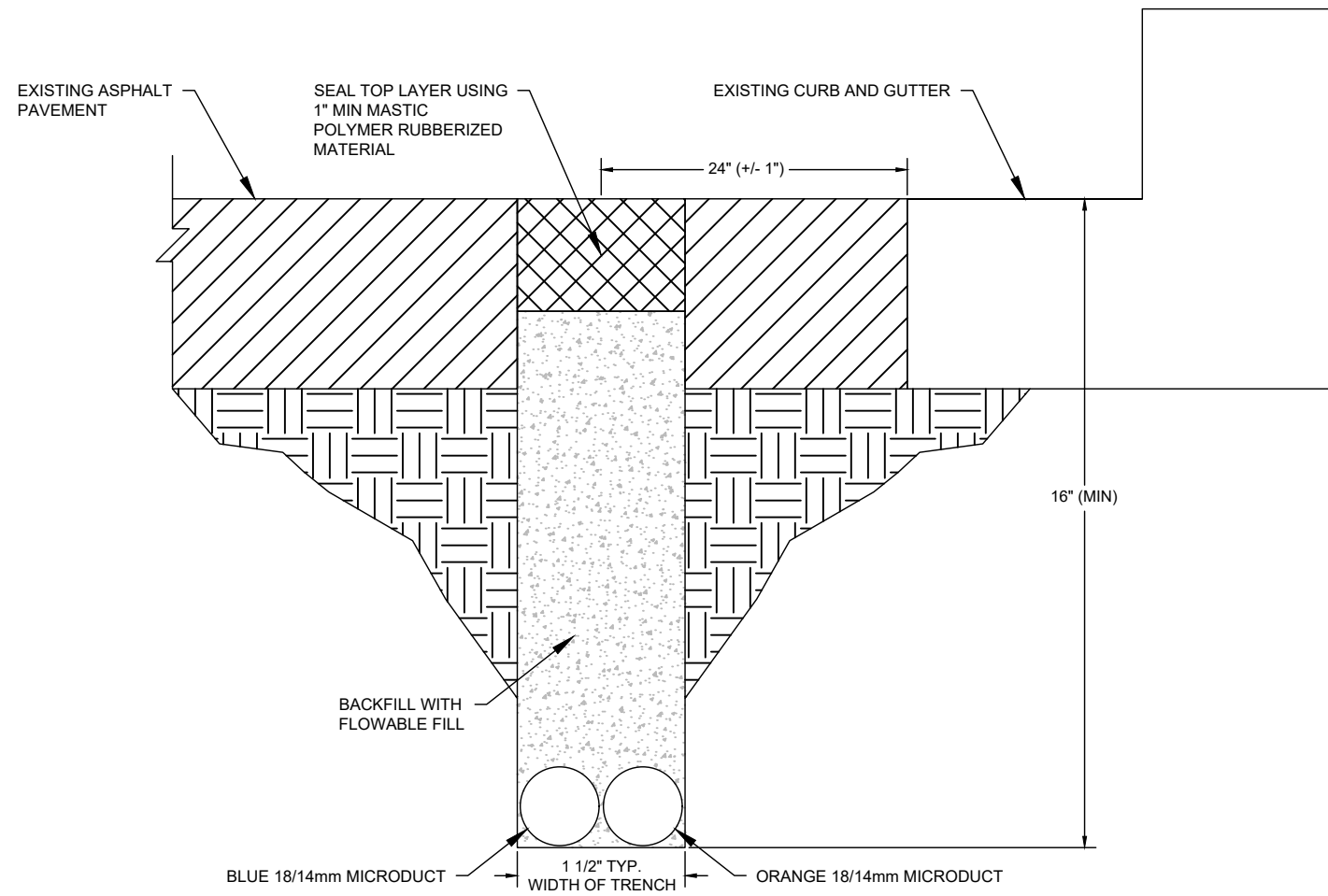

### TYPICAL MICROTRENCH DETAIL

N.T.S.

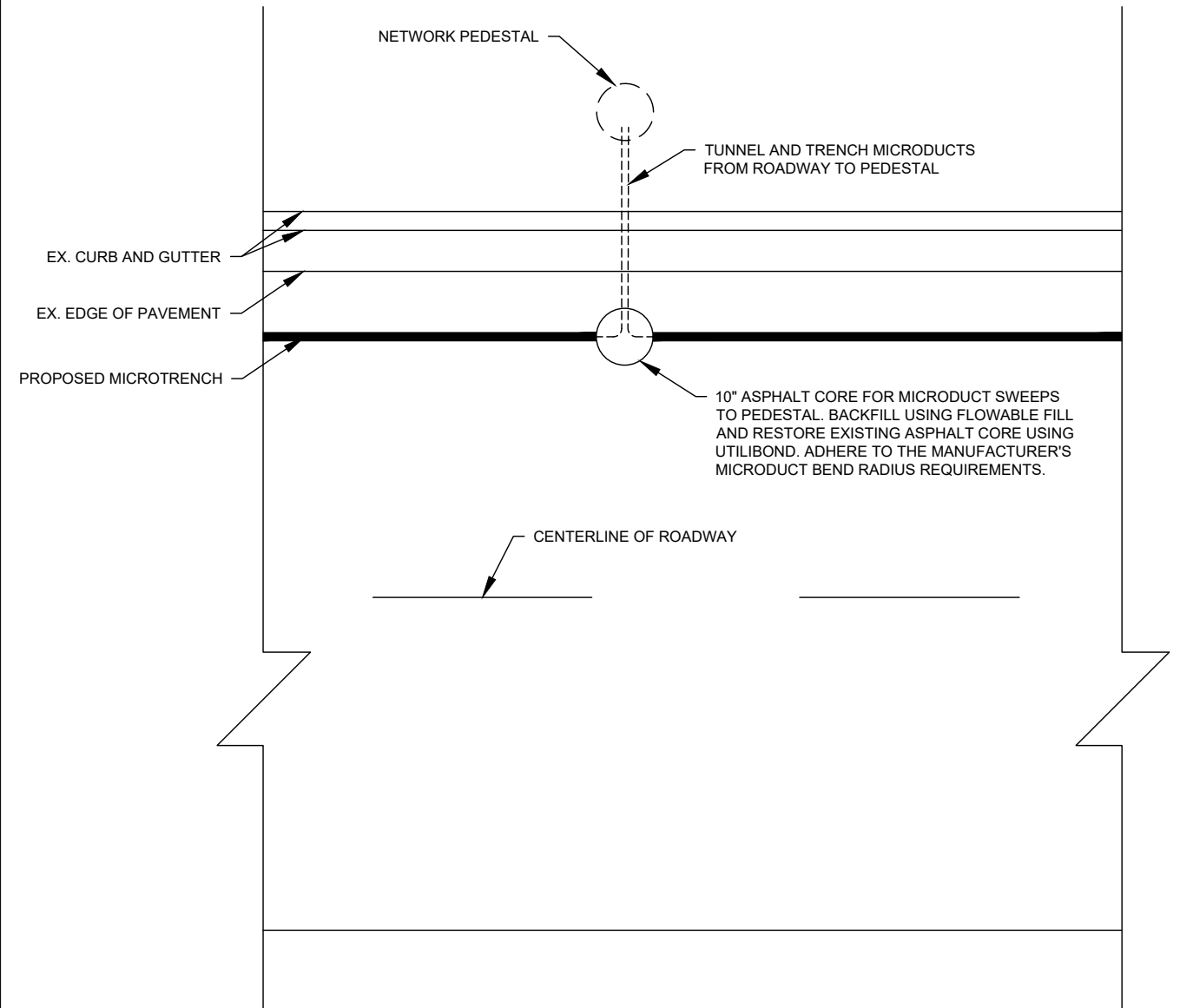

### ASPHALT CORING AND MICROTRENCH SWEEP DETAIL

N.T.S.

| REV | DATE | BY | DESCRIPTION |
|-----|------|----|-------------|
|     |      |    |             |
|     |      |    |             |
|     |      |    |             |
|     |      |    |             |



1405 West 1600 North  
 Mapleton, UT 84664  
 (801) 489-6253

**MAPLETON CITY**  
 MICROTRENCH INSTALLATION DETAILS

DATE 08/12/2022  
 DRAWING NO. SD-11

# Appendix A

Quazite Junction Box

# UNDERGROUND ENCLOSURES

UG-19



# Hubbell Underground Enclosures

Strength, performance, quality, and outstanding customer service have been hallmarks of all Hubbell underground enclosure brands for more than 40 years. The industry leader for applications in non-deliberate traffic areas, our enclosures provide rugged and cost-effective protection for a variety of electric utility, commercial & industrial, communications, water and gas equipment while meeting the specific demands of your industry.

All Hubbell underground enclosure brands come backed with cutting-edge engineering expertise and a total commitment to quality that is designed into our products. Our engineers are respected and valued advisors throughout the industry and our quality processes are among the most sophisticated in application. When you need unyielding performance and reliability, Hubbell underground enclosure brands are the right choice.

Hubbell is proud to offer the wide selection of underground enclosures found in this catalog. The following pages outline our industry leading Quazite, Quazite FRP and PenCell brands. In addition to our core products and options, Hubbell can help customize a solution for your project and application.



|                                       |           |  |            |                                      |     |
|---------------------------------------|-----------|--|------------|--------------------------------------|-----|
| Hubbell Enclosures .....              | 4         | 6" x 8" Straight Wall.....               | 77         | 12" x 18" .....                      | 177 |
| Quazite Size Chart .....              | 5         | 10" x 15" Straight and Flared Wall ..... | 78         | 12" x 20" .....                      | 178 |
| Quazite FRP Size Chart .....          | 6         | 11" x 18" Straight and Flared Wall ..... | 80         | 12" x 24" .....                      | 179 |
| PenCell Size Chart .....              | 7         | 11" x 21" Straight Wall.....             | 82         | 18" x 18" .....                      | 180 |
| ANSI Tier Selection & Placement ..... | 8         | 11" x 32" Straight and Flared Wall ..... | 83         | 18" x 24" .....                      | 181 |
| ANSI Tier Selection Guide .....       | 10        | 12" x 12" Straight and Flared Wall ..... | 85         | 18" x 30" .....                      | 182 |
|                                       |           | 13" x 24" Straight and Flared Wall ..... | 87         | 24" x 24" .....                      | 183 |
| <b>Quazite Enclosures .....</b>       | <b>12</b> | 15" x 17" Straight and Flared Wall ..... | 89         | 24" x 36" .....                      | 184 |
| Quazite Selection Guide .....         | 14        | 15" x 27" Straight and Flared Wall ..... | 91         | 24" x 48" .....                      | 185 |
| Quazite Size Chart .....              | 16        | 16" x 22" Straight and Flared Wall ..... | 93         | 24" x 60" .....                      | 186 |
| Drawings .....                        | 17        | 17" x 30" Straight and Flared Wall ..... | 95         | 30" x 36" .....                      | 187 |
| 6" x 8" PC Style .....                | 17        | 24" x 24" Straight Wall.....             | 98         | 30" x 48" .....                      | 188 |
| 8" x 8" PC Style .....                | 18        | 24" x 36" Straight and Flared Wall ...   | 100        | 30" x 60" .....                      | 189 |
| 8" x 18" PC Style .....               | 19        | 24" x 60" Flared Wall.....               | 104        | 36" x 36" .....                      | 190 |
| 10" x 15" PT Style .....              | 20        | 30" x 48" Straight and Flared Wall ..... | 106        | 36" x 48" .....                      | 191 |
| 10" x 15" PG Style .....              | 21        | 30" x 48" Corrugated Wall .....          | 110        | 36" x 60" .....                      | 192 |
| 11" x 18" PG Style .....              | 22        | 30" x 60" Straight Wall.....             | 112        | 48" x 48" .....                      | 185 |
| 11" x 18" PC Style .....              | 23        | 30" x 60" Corrugated Wall .....          | 114        | PR (PEMR) Series                     |     |
| 11" x 20" PG Style .....              | 24        | 36" x 36" Straight Wall.....             | 116        | 12" Round.....                       | 193 |
| 12" x 12" PC Style .....              | 25        | 36" x 60" Straight Wall.....             | 118        | Cover Options.....                   | 194 |
| 12" x 12" PX Style .....              | 26        | 36" x 60" Corrugated Wall .....          | 120        | Accessories.....                     | 195 |
| 13" x 24" PG Style .....              | 27        | 36" x 72" Straight Wall.....             | 122        | Options .....                        | 197 |
| 13" x 24" PD Style .....              | 28        | 36" x 72" Corrugated Wall .....          | 124        | Color Options .....                  | 198 |
| 13" x 24" PC Style .....              | 29        | 36" x 96" Corrugated Wall .....          | 126        | PenCell Option System.....           | 199 |
| 13" x 24" PT Style .....              | 30        | 48" x 48" Corrugated Wall .....          | 128        | Installation Guide.....              | 200 |
| 17" x 30" PD Style .....              | 31        | 48" x 72" Corrugated Wall .....          | 130        | EZ-Locate Installation.....          | 202 |
| 17" x 30" PG Style .....              | 32        | 48" x 78" Corrugated Wall .....          | 132        | Hole Cutting Instructions.....       | 205 |
| 17" x 30" PC Style .....              | 34        | 48" x 96" Corrugated Wall .....          | 134        | EZ Nut Cleaning/Replacement.....     | 206 |
| 17" x 30" PT Style .....              | 35        | 78" x 96" Corrugated Wall .....          | 136        | Concrete Collar Applications.....    | 207 |
| 24" x 24" PG Style .....              | 36        | 20" Round.....                           | 138        | Internal Bracing.....                | 208 |
| 24" x 36" PD Style .....              | 37        | 27" Round.....                           | 139        | Quazite Part Number System .....     | 210 |
| 24" x 36" PG Style .....              | 38        | 32" Round.....                           | 140        | Quazite FRP Part Number System ..... | 212 |
| 30" x 48" PG Style .....              | 40        | 39" Round.....                           | 141        | PenCell Part Number System .....     | 214 |
| 30" x 48" PD Style .....              | 42        | Cover Options.....                       | 142        | Terms & Conditions .....             | 216 |
| 30" x 60" PG Style .....              | 43        | Color Options .....                      | 143        |                                      |     |
| 36" x 36" PG Style .....              | 44        | Quazite FRP Options .....                | 144        |                                      |     |
| 36" x 60" PG Style .....              | 46        |  |            |                                      |     |
| 36" x 72" PG Style .....              | 48        | <b>PenCell .....</b>                     | <b>149</b> |                                      |     |
| 48" x 48" PG Style .....              | 49        | PenCell Selection Guide.....             | 151        |                                      |     |
| 48" x 60" PG Style .....              | 50        | PenCell Size Chart .....                 | 152        |                                      |     |
| 48" x 72" PG Style .....              | 51        | PenCell Drawings .....                   | 154        |                                      |     |
| 48" x 78" PG Style .....              | 52        | DT Series                                |            |                                      |     |
| 48" x 96" PG Style .....              | 53        | 11" x 18" .....                          | 154        |                                      |     |
| 27" Round Polymer Concrete Style ..   | 54        | 12" x 12" .....                          | 155        |                                      |     |
| 39" Round Polymer Concrete Style ..   | 56        | 13" x 24" .....                          | 156        |                                      |     |
| 5" x 16" Median Barrier Enclosure ..  | 58        | 17" x 30" .....                          | 157        |                                      |     |
| 10" x 12" Jersey Style Median Barrier |           | 24" x 36" .....                          | 160        |                                      |     |
| Enclosure.....                        | 59        | 30" x 48" .....                          | 162        |                                      |     |
| Cell Site Enclosure .....             | 60        | PE Series                                |            |                                      |     |
| Communications Cabinet Foundations    |           | 6" Round.....                            | 164        |                                      |     |
| Information .....                     | 61        | 9" Round.....                            | 165        |                                      |     |
| Cover Options / Logo Codes .....      | 62        | 10" Round.....                           | 166        |                                      |     |
| Dimensional Data.....                 | 65        | 14" Rectangular .....                    | 167        |                                      |     |
| EZ Auger Upgrade Kits .....           | 66        | 20" Rectangular .....                    | 168        |                                      |     |
| Quazite Options .....                 | 67        | 30" Rectangular .....                    | 169        |                                      |     |
| Dividers .....                        | 69        | 36" Rectangular .....                    | 170        |                                      |     |
| Box Collars .....                     | 70        | 10" x 15" PE series.....                 | 171        |                                      |     |
| Color Options .....                   | 71        | 11" x 18" PE series.....                 | 172        |                                      |     |
| Specifications and Data .....         | 72        | 13" x 24" PE series.....                 | 173        |                                      |     |
|                                       |           | 17" x 30" PE series.....                 | 174        |                                      |     |
| <b>Quazite FRP .....</b>              | <b>73</b> | PM (PEM) Series                          |            |                                      |     |
| Quazite FRP Selection Guide .....     | 75        | 10" x 10" .....                          | 175        |                                      |     |
| Quazite FRP Size Chart.....           | 76        | 12" x 12" .....                          | 176        |                                      |     |



# Hubbell Underground Enclosures

Hubbell offers three distinct brands of underground enclosures. All three are built with the same attention to quality and performance that you know and expect from Hubbell. Each brand is made of a different base material. Our comprehensive product offering is tailored to ensure that your application requirements are met, no matter what. Based on your design style preference, Hubbell offers Quazite® monolithic polymer concrete, Quazite® FRP fiberglass-reinforced polymer, and PenCell HDPE enclosure products. All three brands offer superior performance and unique benefits.

## Quazite® Enclosures

Polymer concrete is made from select-grade aggregates in combination with a polymer resin system. When combined through a process of mixing, molding, and curing, an extremely powerful cross-linked bond is formed. Precast polymer concrete is reinforced with fiberglass to give it additional strength and rigidity.

Polymer Concrete



## Quazite® FRP Enclosures

Fiberglass-reinforced polymer, also called FRP, is a special combination of polymer concrete and fiber-reinforced polymer. This hybrid construction, formed from an FRP shell and a polymer concrete ring and cover, delivers a high strength, lightweight, abrasion-resistant product that is protected from ultraviolet rays.

Fiberglass Reinforced Polymer



## PenCell® Enclosures

Structural foam molded high density polyethylene, also called HDPE, is a light weight, high strength plastic molding process that provides outstanding structural integrity and durability. HDPE enclosures are mated with covers made from a variety of materials: HDPE, polymer concrete or steel. This combination creates a highly versatile choice for underground utility enclosures where low weight and high strength are necessary.

High Density Polyethylene (HDPE)



10"  
(254mm)  
SQUARE

# Dimensions / Data

## 17" x 30" PG Style Polymer Concrete (Stackable) Assembly

**Hex Head Bolts are Standard**

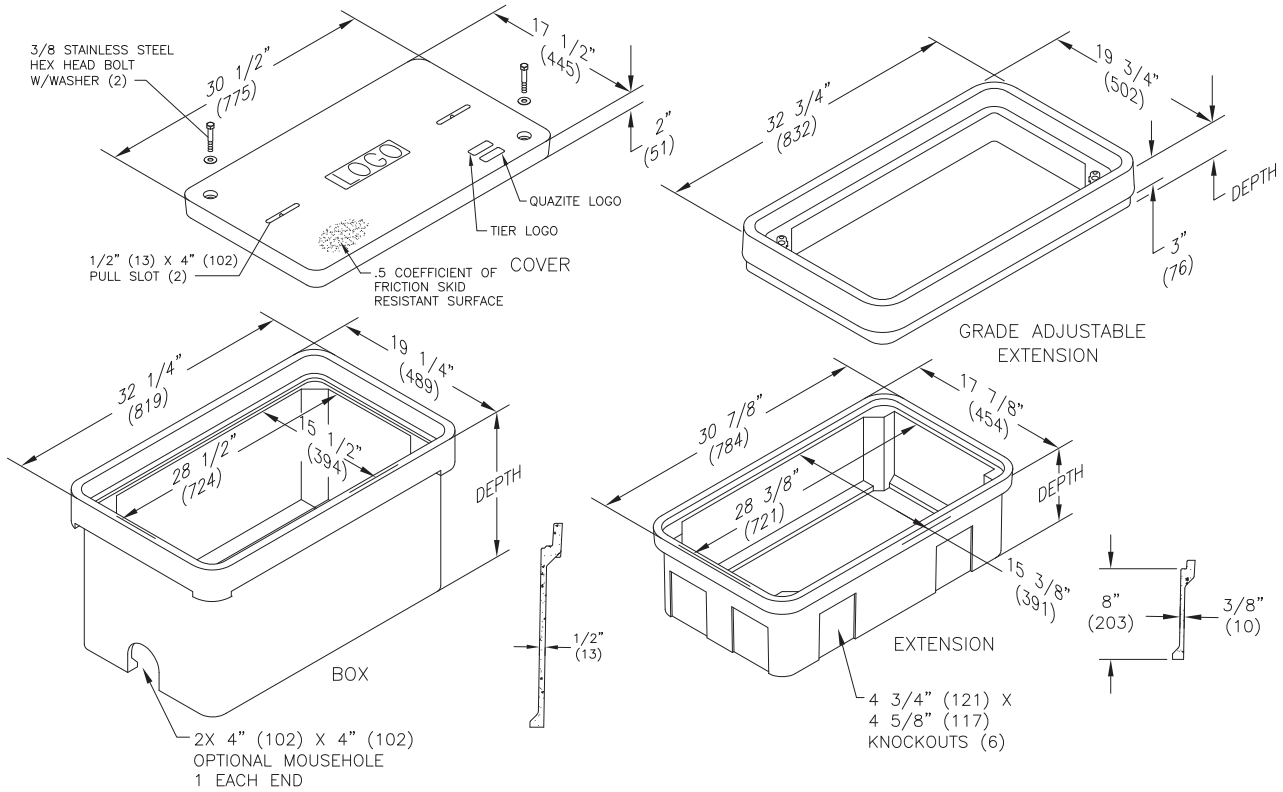

### Covers

|    | DESCRIPTION | TIER | DESIGN / TEST LOAD # | WEIGHT # | PALLET QTY | PART NO.     |
|----|-------------|------|----------------------|----------|------------|--------------|
| UL | W/ 2 Bolts  | 8    | 8,000 / 12,000       | 52       | 20         | PG1730CA00** |
| UL | W/ 2 Bolts  | 15   | 15,000 / 22,500      | 83       | 20         | PG1730HA00** |
| UL | W/ 2 Bolts  | 22   | 22,500 / 33,750      | 83       | 20         | PG1730HH00** |
| UL | No Bolts    | 8    | 8,000 / 12,000       | 52       | 20         | PG1730WA00** |

To order gasketed covers, replace the letter "A" with the letter "G".

Replace \*\* with a logo code found on page 62. See page 68 for meter and touch/radio read cover options.

NOTE: Gasketed covers and bolt grommets must be used with a gasketed box. Gaskets reduce the inflow of fluids but do not make the enclosure water tight.

Available with EZ Locate. See page 67 for more information.

QUAZITE



# Dimensions / Data 17" x 30" PG Style Polymer Concrete (Stackable) Assembly (Continued)

**Hex Head Bolts are Standard**
**Boxes (Box depths 22" thru 30" must be used as bottom of any stack)**

|                  | DESCRIPTION          | DEPTH   | TIER | DESIGN / TEST LOAD # | WEIGHT # | PALLET QTY | PART NO.   |
|------------------|----------------------|---------|------|----------------------|----------|------------|------------|
| <br><br><br><br> | Standard Open Bottom | 12"     | 22   | 22,500 / 33,750      | 67       | 10         | PG1730BA12 |
|                  |                      | 18"     |      | 22,500 / 33,750      | 94       | 8          | PG1730BA18 |
|                  |                      | 22"     |      | 22,500 / 33,750      | 106      | 6          | PG1730BA22 |
|                  |                      | 24"     |      | 22,500 / 33,750      | 122      | 6          | PG1730BA24 |
|                  |                      | 30"     |      | 22,500 / 33,750      | 144      | 4          | PG1730BA30 |
| <br><br><br><br> | Solid Bottom         | 12 1/2" | 22   | 22,500 / 33,750      | 85       | 10         | PG1730DA12 |
|                  |                      | 18 1/2" |      | 22,500 / 33,750      | 112      | 8          | PG1730DA18 |
|                  |                      | 22 1/2" |      | 22,500 / 33,750      | 124      | 6          | PG1730DA22 |
|                  |                      | 24 1/2" |      | 22,500 / 33,750      | 137      | 6          | PG1730DA24 |
|                  |                      | 30 1/2" |      | 22,500 / 33,750      | 150      | 4          | PG1730DA30 |

To order boxes with 2 standard mouseholes, replace the letter "A" with the letter "B".  
 To order gasketed boxes, replace the letter "A" with the letter "G".  
 NOTE: Gasketed cover and bolt grommets must be used with a gasketed box. Gaskets reduce the inflow of fluids but do not make the enclosure water tight.

**Bottom Extensions (for use under 12" and 18" boxes only, one per box)**

| DESCRIPTION  | DEPTH  | TIER | DESIGN / TEST LOAD # | WEIGHT # | PALLET QTY | PART NO.   |
|--------------|--------|------|----------------------|----------|------------|------------|
| Open bottom  | 8 3/4" | 22   | 22,500 / 33,750      | 36       | 12         | PG1730EA08 |
| Solid bottom | 9 1/4" | 22   | 22,500 / 33,750      | 55       | 12         | PG1730RA08 |

**Grade Adjustable Extension (for use on top of box only, one per box)**

| DESCRIPTION      | DEPTH  | TIER | DESIGN / TEST LOAD # | WEIGHT # | PALLET QTY | PART NO.   |
|------------------|--------|------|----------------------|----------|------------|------------|
| 3" Top extension | 5 1/8" | 22   | 22,500 / 33,750      | 48       | 12         | PG1730ED03 |

**QUAZITE**

# Dimensions / Data

## 24" x 36" PG Style Polymer Concrete (Stackable) Assembly

**Hex Head Bolts are Standard**

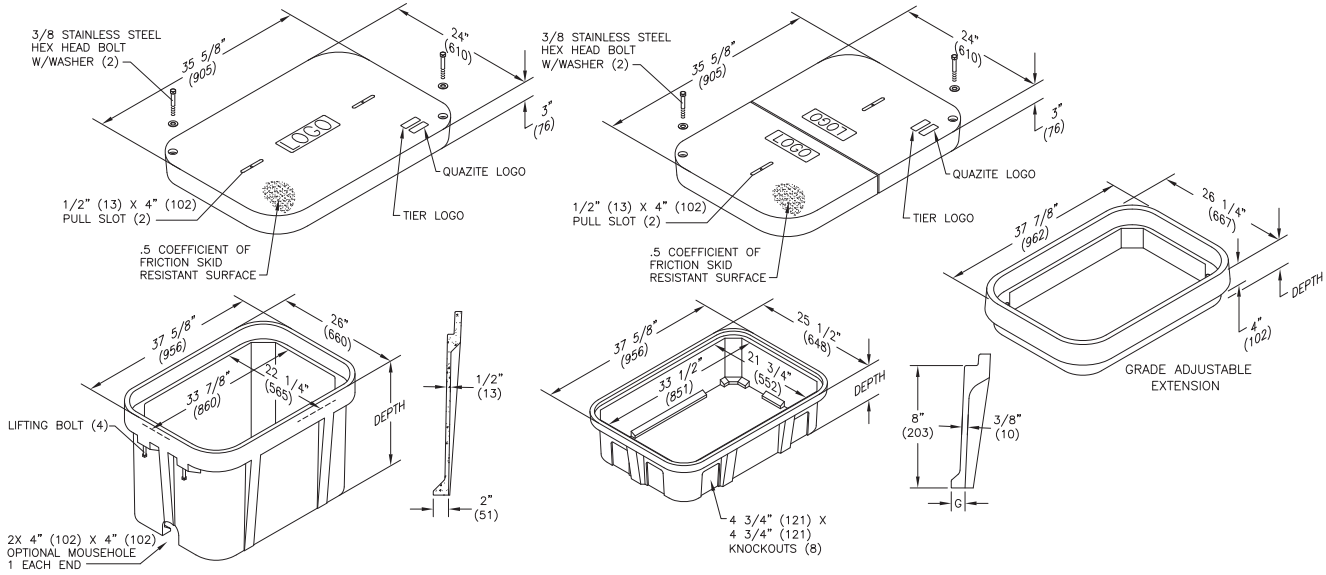

### Covers

|    | DESCRIPTION       | TIER | DESIGN / TEST LOAD # | WEIGHT # | PALLET QTY | PART NO.     |
|----|-------------------|------|----------------------|----------|------------|--------------|
| UL | W/ 2 Bolts        | 8    | 8,000 / 12,000       | 100      | 10         | PG2436CA00** |
|    | 2 piece w/2 Bolts | 8    | 8,000 / 12,000       | 122      | 10         | PG2436CS00** |
| UL | W/ 2 Bolts        | 15   | 15,000 / 22,500      | 115      | 10         | PG2436HA00** |
| UL | 2 piece w/2 Bolts | 15   | 15,000 / 22,500      | 122      | 10         | PG2436HS00** |
| UL | W/ 2 Bolts        | 22   | 22,500 / 33,750      | 122      | 10         | PG2436HH00** |
|    | 2 piece w/2 Bolts | 22   | 22,500 / 33,750      | 202      | 10         | PG2436H544** |
| UL | No Bolts          | 8    | 8,000 / 12,000       | 100      | 10         | PG2436WA00** |

To order gasketed covers, replace the letter "A" with the letter "G".  
 Replace \*\* with a logo code found on page 62. See page 68 for meter and touch/radio read cover options.  
 NOTE: Gasketed covers and bolt grommets must be used with a gasketed box. Gaskets reduce the inflow of fluids but do not make the enclosure water tight.  
 Available with EZ Locate. See page 67 for more information.

QUAZITE

# Dimensions / Data 24" x 36" PG Style Polymer Concrete (Stackable) Assembly (Continued)

Hex Head Bolts are Standard

## Boxes (Box depths 24" thru 42" must be used as bottom of any stack)

|                  | DESCRIPTION          | DEPTH   | TIER | DESIGN / TEST LOAD # | WEIGHT # | PALLET QTY | PART NO.   |
|------------------|----------------------|---------|------|----------------------|----------|------------|------------|
| <br><br><br><br> | Standard Open Bottom | 18"     | 22   | 22,500 / 33,750      | 141      | 4          | PG2436BA18 |
|                  |                      | 24"     |      | 22,500 / 33,750      | 180      | 3          | PG2436BA24 |
|                  |                      | 30"     |      | 22,500 / 33,750      | 196      | 2          | PG2436BA30 |
|                  |                      | 36"     |      | 22,500 / 33,750      | 254      | 2          | PG2436BA36 |
|                  |                      | 42"     |      | 22,500 / 33,750      | 293      | 1          | PG2436BA42 |
| <br><br><br><br> | Solid Bottom         | 18 1/2" | 22   | 22,500 / 33,750      | 171      | 4          | PG2436DA18 |
|                  |                      | 24 1/2" |      | 22,500 / 33,750      | 228      | 3          | PG2436DA24 |
|                  |                      | 30 1/2" |      | 22,500 / 33,750      | 238      | 2          | PG2436DA30 |
|                  |                      | 36 1/2" |      | 22,500 / 33,750      | 282      | 2          | PG2436DA36 |
|                  |                      | 42 1/2" |      | 22,500 / 33,750      | 321      | 1          | PG2436DA42 |

To order boxes with 2 standard mouseholes, replace the letter "A" with the letter "B".

To order gasketed boxes, replace the letter "A" with the letter "G".

NOTE: 24" thru 42" boxes must be used as bottom on any stack.

NOTE: Gasketed covers and bolt grommets must be used with a gasketed box. Gaskets reduce the inflow of fluids but do not make the enclosure water tight.

## Bottom Extensions (for use under 12" and 18" boxes only, one per box)

| DESCRIPTION  | DEPTH  | TIER | DESIGN / TEST LOAD # | WEIGHT # | PALLET QTY | PART NO.   |
|--------------|--------|------|----------------------|----------|------------|------------|
| Open bottom  | 8 3/4" | 22   | 22,500 / 33,750      | 81       | 6          | PG2436EA08 |
| Solid bottom | 9 1/4" | 22   | 22,500 / 33,750      | 95       | 6          | PG2436RA08 |

## Grade Adjustable Extension

| DESCRIPTION                  | DEPTH  | TIER | DESIGN / TEST LOAD # | WEIGHT # | PALLET QTY | PART NO.   |
|------------------------------|--------|------|----------------------|----------|------------|------------|
| 4" top extension, 1/2 thread | 7 1/8" | 22   | 22,500 / 33,750      | 80       | 6          | PG2436ED04 |
| 4" top extension, 3/8 thread | 7 1/8" | 22   | 22,500 / 33,750      | 80       | 6          | PG2436E503 |

# Appendix B

Channell Pedestal

# CPH CHALLENGER SERIES PEDESTALS

CPH911, CPH920, CPH1022



Stake  
(S2 Shown)



Bracket  
(B2 Shown)



Lock  
(L00 Shown)



Self-locating  
Cover Security  
Lock Receiver



Winterized Drop  
(A1 Shown)



42" Joint Trench  
Stake (2 per ctn.)  
P/N ST01001

Designed specifically for housing passive equipment, these special versions of the Channell CPH911, CPH920, and CPH1022 pedestals feature direct-bury bases with a high rib design that are less likely to lean or tilt and do not require stakes for installation. A special self-locating cover ensures that the pedestals lock properly without additional alignment. The covers include Channell's Self-Lock<sup>®</sup> security hardware.

## FEATURES

- 9" and 10" diameter round profiles provide maximum workspace and bend radius provisions for all passives, cables and connectors
- Round pedestal style maintains a consistent look with legacy pedestals in the field
- Constructed of durable, high-strength materials for maximum security and long service life
- Universal equipment mounting bracket for passives facilitates installation
- Optional stake mounting provision for joint trench or other special applications

# PART NUMBER MATRIX

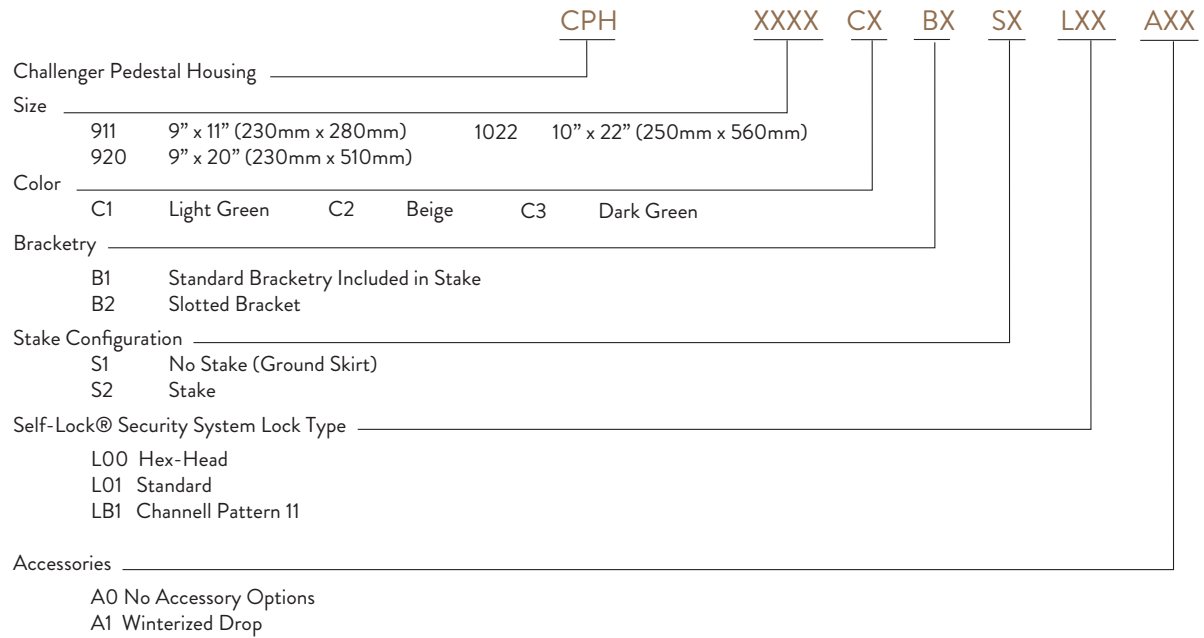

## DIMENSIONS

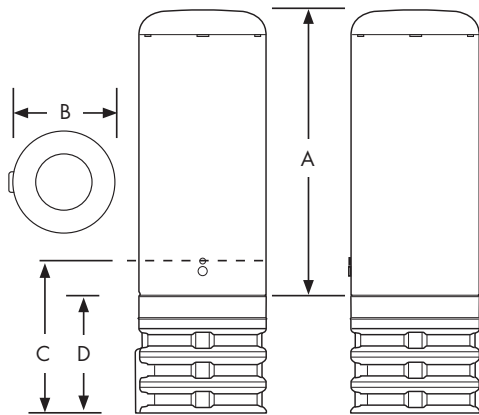

|          | A                | B                 | C                | D                |
|----------|------------------|-------------------|------------------|------------------|
| CPH 911  | 13.0"<br>(330mm) | 9.5"<br>(240mm)   | 14.5"<br>(370mm) | 10.5"<br>(265mm) |
| CPH 920  | 22.0"<br>(560mm) | 9.5"<br>(240mm)   | 14.5"<br>(370mm) | 10.5"<br>(265mm) |
| CPH 1022 | 24.0"<br>(610mm) | 10.75"<br>(275mm) | 14.5"<br>(370mm) | 10.5"<br>(265mm) |

Note: Dimensions in inches (mm)



## CHANNELL

Where The Industry Connects.

**WORLDWIDE HEADQUARTERS:** Channell Commercial Corporation, Rockwall, TX, United States • Tel 800.423.1863 • Fax 951.296.2322

**CANADA:** Channell Canada, Inc., Mississauga, ON, Canada • Tel 905.565.1700 • Fax 905.565.8282

**EUROPE, MIDDLE EAST, AFRICA:** Channell Ltd., Dartford, United Kingdom • Tel 44.1322.312590 • Fax 44.1322.508490

**AUSTRALIA, ASIA, PACIFIC RIM:** Channell Pty. Ltd., Seven Hills, NSW, Australia • Tel 61.2.8884.4111 • Fax 61.2.8814.8841

**DEVELOPING LOCATION:** Mexico City, D.F., Mexico

[www.channell.com](http://www.channell.com)

All specifications subject to change without notice. © 2020 Channell Commercial Corporation. All rights reserved.

# OSV OPTIMUS SUPER VENT PEDESTAL

(OSV2436, OSV2442)



OSV2436

OSV2442

## FEATURES

- OSV Super Vent designed to house fiber optic high-heat nodes
- Channell's UV Resistant Heat Dissipation Cover (HDC)
- 360 degrees access to working equipment
- Channell's Self-Locking system
- Molded lifting handle designed into the cover
- BULK's racking designed for cable management and securing splice enclosure
- Super-heavy duty node bracket for heavy-weight nodes

# PRODUCT SUMMARY

Channell's Optimus Super Vent (OSV) Pedestal is a robust platform for protecting fiber optic nodes and is synonymous with reliability and performance in the outside plant environment. The OSV platform is a direct replacement to the SPH pedestal housings which have been the industry standard for many years.

Channell's Heat Dissipation Cover (HDC) is fully vented on all four sides and has an insulated attic area to help reduce costly node failures caused by overheating. The base is Channell's BULK vault body which features the highest performance standards in the industry.

BULK's racking designed for cable management and securing splice enclosure (G6 shown)

Channell's UV Resistant Heat Dissipation Cover (HDC)

Molded lifting handle designed into the cover

Channell's Self-Locking system



L01 Standard (P-Key)



LB1 LB Pattern



LH1 Hex Self-Lock

BULK Vault deflection brackets

360 degrees access to working equipment



Free-breathing closures



Lightweight ultra-strong vault body



OSV 2436 Dimensions

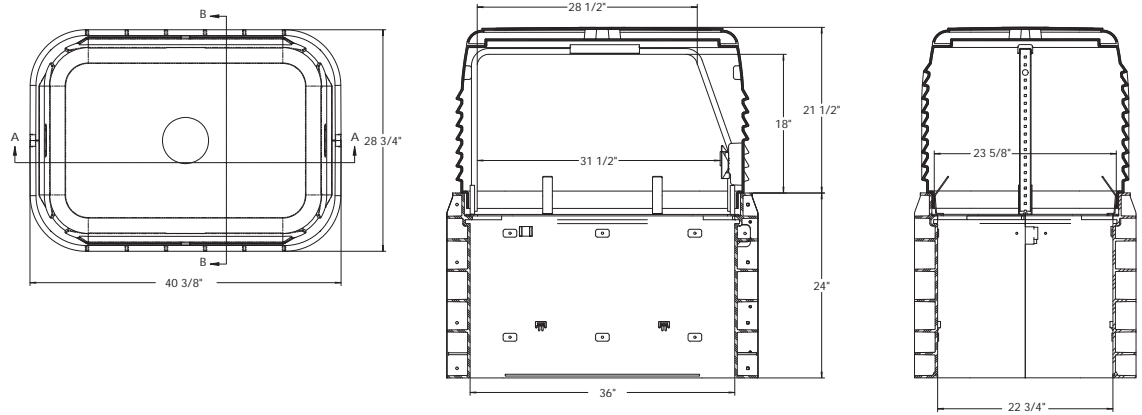

OSV 2442 Dimensions

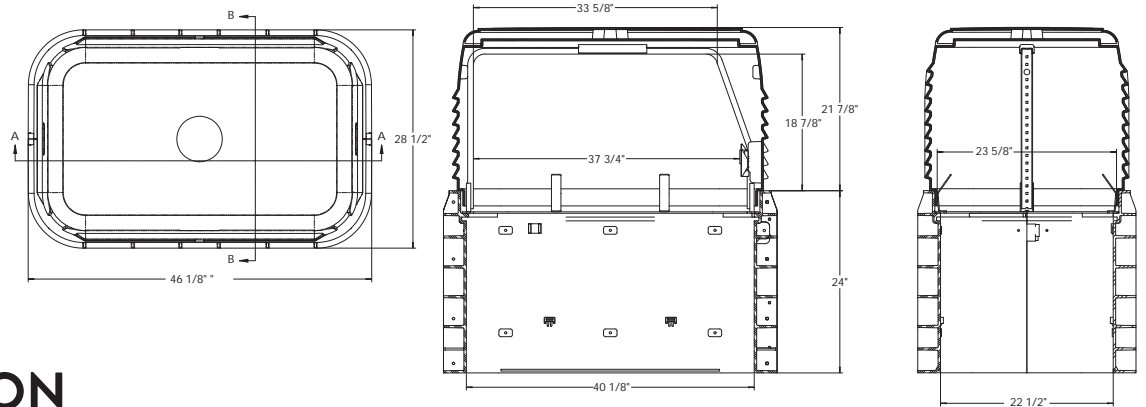

# APPLICATION

Channell’s broadband products are known for their superior quality, but what sets the OSV apart from the competition is its true internal dimensions and proven heat performance. The BULK Vault’s deflection brackets shown below prevent the pedestal from caving in over time due to snow loads and other environmental conditions. All of these features ensure the OSV will protect your fiber nodes for many years into the future.

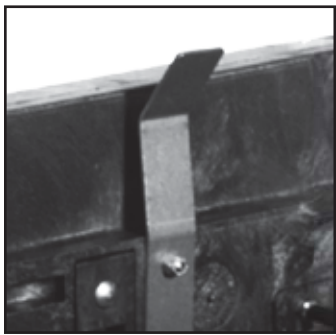

(4) BULK Vault deflection brackets



90° Splice closure mounting

# PART NUMBER MATRIX

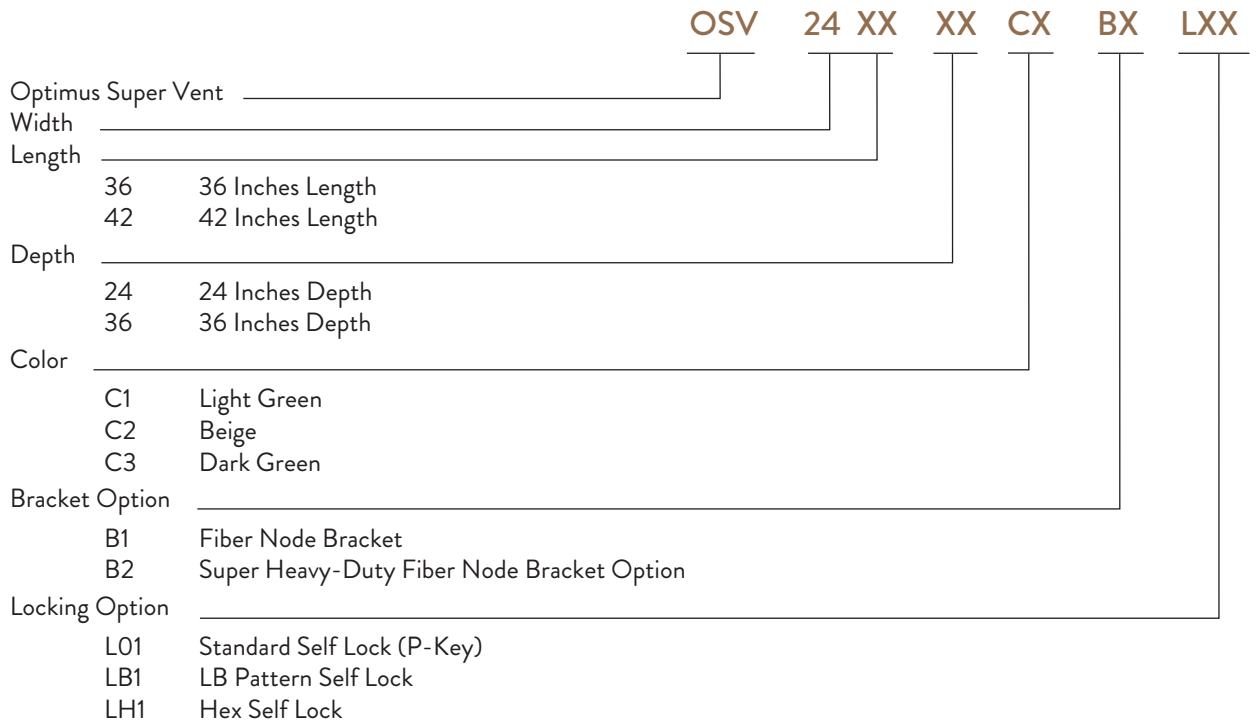

**CHANNELL**

Where The Industry Connects.

**WORLDWIDE HEADQUARTERS:** Channell Commercial Corporation, Rockwall, TX, United States • Tel 800.423.1863 • Fax 951.296.2322

**CANADA:** Channell Canada, Inc., Mississauga, ON, Canada • Tel 905.565.1700 • Fax 905.565.8282

**EUROPE, MIDDLE EAST, AFRICA:** Channell Ltd., Dartford, United Kingdom • Tel 44.1322.312590 • Fax 44.1322.508490

**AUSTRALIA, ASIA, PACIFIC RIM:** Channell Pty. Ltd., Seven Hills, NSW, Australia • Tel 61.2.8884.4111 • Fax 61.2.8814.8841

**DEVELOPING LOCATION:** Mexico City, D.F., Mexico

[www.channell.com](http://www.channell.com)

All specifications subject to change without notice. © 2020 Channell Commercial Corporation. All rights reserved.

# OPTIMUS PEDESTAL

OP12123, OP12126



OP12123



OP12126



Channell's Optimus Pedestal (OP) is the industry standard in Fiber Pedestal Enclosures. Channell's free-breathing pedestal enclosures are available in a wide range of sizes and configurations. They are constructed of rugged, high-performance thermoplastic material and designed to be craft-friendly.

## FEATURES

- Fully modular and designed to support a full range of both broadband and narrowband network applications for copper, coax, and hybrid fiber/coax system installations
- Engineered to be cost effective for both new installations and future upgrade programs, OP Series enclosures provide configurations for splicing, cable management, and loop electronics deployments
- Factory equipped heavy gauge steel support structures are protected with 3M Powder Coating. Oversized, interlocking base designs accommodate multiple conduit entrances and provide a solid mounting foundation, without the need of additional mounting stakes

# TESTING SPECIFICATIONS

- Designed to meet Bellcore GR-13 requirements and feature full 360 degree working access with Channell's Self-Lock self-latching cover system. Channell's Heat Dissipation Covers (HDC) safeguard the performance of enclosed electronic equipment.

## PART NUMBER MATRIX

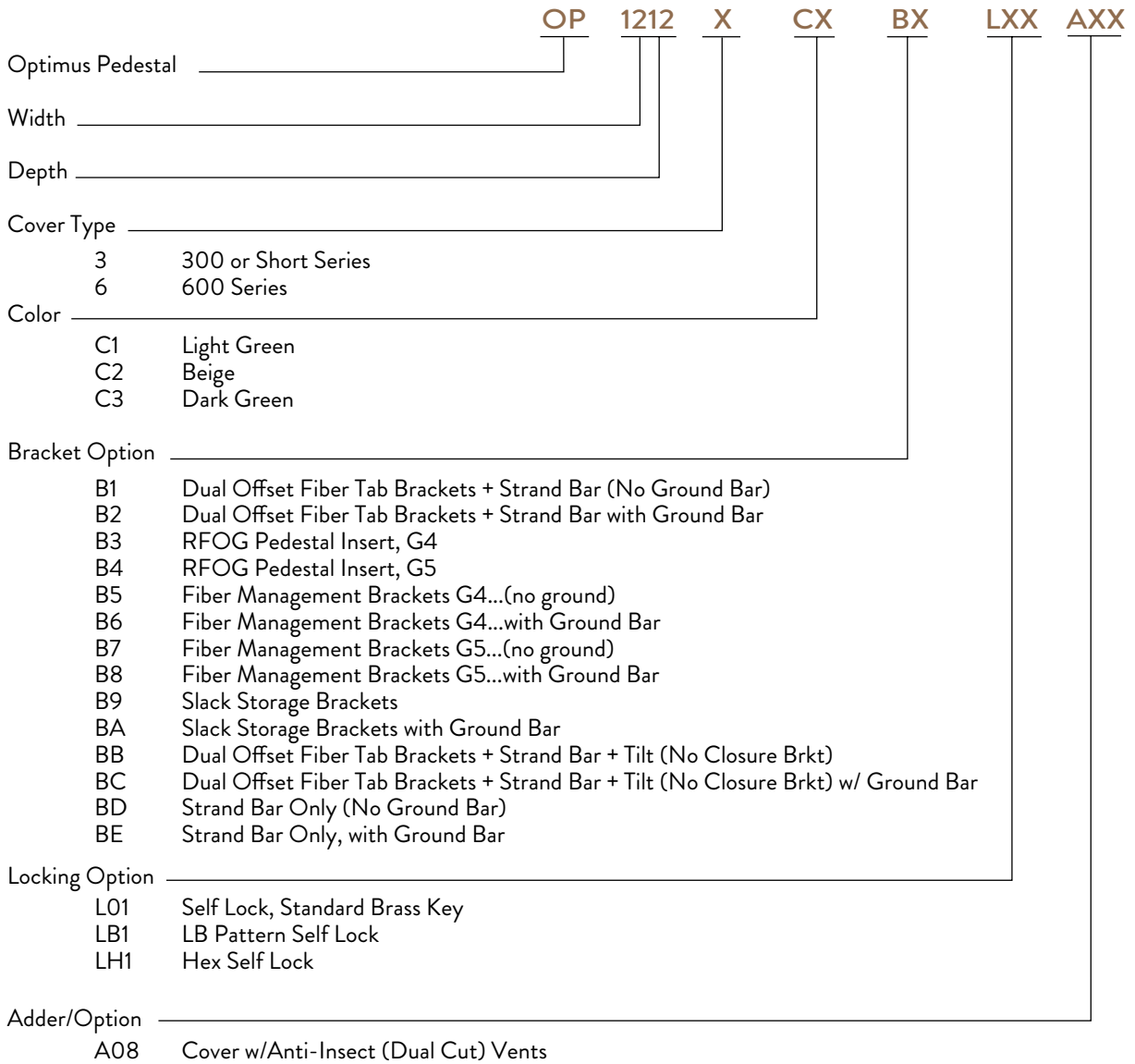

**CHANNELL**

Where The Industry Connects.

# Appendix C

AFL Splice Enclosure and Splitter

A scenic view of a rural landscape. In the foreground, a utility pole stands on the left, with a white picket fence running across the middle ground. Behind the fence is a large, two-story red brick house with a white porch and a smaller red brick outbuilding. The background shows rolling green hills, trees with autumn foliage, and a blue sky with scattered clouds. A road with a guardrail is visible in the lower right corner.

# FTTx PRODUCT SOLUTION GUIDE

# Table of Contents

|  |    |
|--|----|
| Introduction   | 3  |
| <b>Central Office</b>  | 4  |
| XFM® Panels  | 4  |
| Poli-MOD® Patch and Splice Modules                           | 5  |
| Wall-mount Panels  | 6  |
| <b>Access</b>  | 7  |
| ADSS Cable and Hardware                                      | 8  |
| ADSS Suspensions   | 9  |
| Trunnions  | 9  |
| Vibration Dampers  | 9  |
| <b>Slack Storage</b>   | 10 |
| Coil Bracket   | 10 |
| Splice Enclosure Mounting Bracket                            | 10 |
| Standoff Bracket for ADSS Hardware Clamps                    | 10 |
| Fiber Storage Units  | 11 |
| Downlead Clamps  | 12 |
| Flat Drop Downlead   | 12 |
| Temporary Grips  | 12 |
| <b>Underground Cable</b>                                     | 13 |
| LMHD OSP MicroCore® Cable                                    | 13 |
| Wrapping Tube Cable with SpiderWeb Ribbon® (SWR®) Technology | 14 |
| <b>Splice Closures</b>                                       | 15 |
| Sealed (Underground and Pole Mount)                          | 15 |
| Apex™ Sealed Splice Closures                                 | 15 |
| Aerial (On Strand)   | 20 |
| <b>Splitting</b>   | 24 |
| Centralized Split  | 24 |
| Exterior Distribution Cabinets                               | 25 |
| Distributed Split  | 27 |

|  |    |
|--|----|
| <b>Network Access Point</b>  | 28 |
| Multiport Terminals  | 28 |
| Hardened Drops   | 29 |
| <b>Premise and Multi-Dwelling Units</b>  | 30 |
| <b>Demarcation</b>   | 31 |
| OptiNID® DUO Enclosure   | 31 |
| <b>Field-Installable Connectors</b>  | 32 |
| Connector Comparison Chart   | 32 |
| FASTConnect® Mechanical Connectors   | 33 |
| FASTConnect® Universal Tool Kit  | 33 |
| FUSEConnect® Splice-on Connectors  | 34 |
| FUSEConnect® Universal Tool Kit  | 35 |
| <b>Cable Assemblies</b>  | 36 |
| Pigtail Assemblies   | 36 |
| Drop Cable Assemblies  | 36 |
| <b>Fusion Splicers</b>   | 37 |
| 90S Single Fiber Fusion Splicer  | 38 |
| 90R Ribbon Fiber Fusion Splicer  | 40 |
| 41S Single Fiber Fusion Splicer  | 42 |
| Accessories for the 90S, 90R and 41S Fusion Splicers                             | 43 |
| <b>Network Test and Inspection</b>   | 44 |
| FlexScan® OTDRs  | 44 |
| FOCUS Flex   | 46 |
| Optical Fiber Identifiers  | 47 |
| Optical Power Meters   | 47 |
| Test Results Manager TRM® 2.0/3.0 Software                                       | 48 |
| <b>Cleaning</b>  | 49 |
| 85% of Network Failures are a Result of Dirty Connectors – Don't Scrub Your Data | 49 |
| One-Click® Cleaners  | 50 |
| Cleaning Kits  | 51 |

# Introduction

Optical fiber is the future that is here now. There is no comparison for speed, bandwidth and latency in any other transmission medium. With continued advancement in the electronics used over the fiber medium, fiber is a communications pipeline built to last. As wireless advancements like 5G make news headlines, they are increasingly relying on deeper fiber networks to backhaul information. No matter how far fiber is going in your network, trust AFL to provide solutions to meet your needs.

AFL offers unmatched end-to-end solutions to meet the demands of a fiber-to-the-x (FTTx) project. For electric utilities, enterprise, and service providers, we provide a full solution of passive components. From the central office to the end point of the network, AFL has a wide variety of fiber cable, hardware, and optical connection products. In addition to these products, AFL also boasts industry leading fusion splicers and testing and inspection equipment.

This guide walks through some typical FTTx network solutions from the headend to “x” – for whatever you are taking fiber to, highlighting some of the typical passive AFL products that can be used for your network.

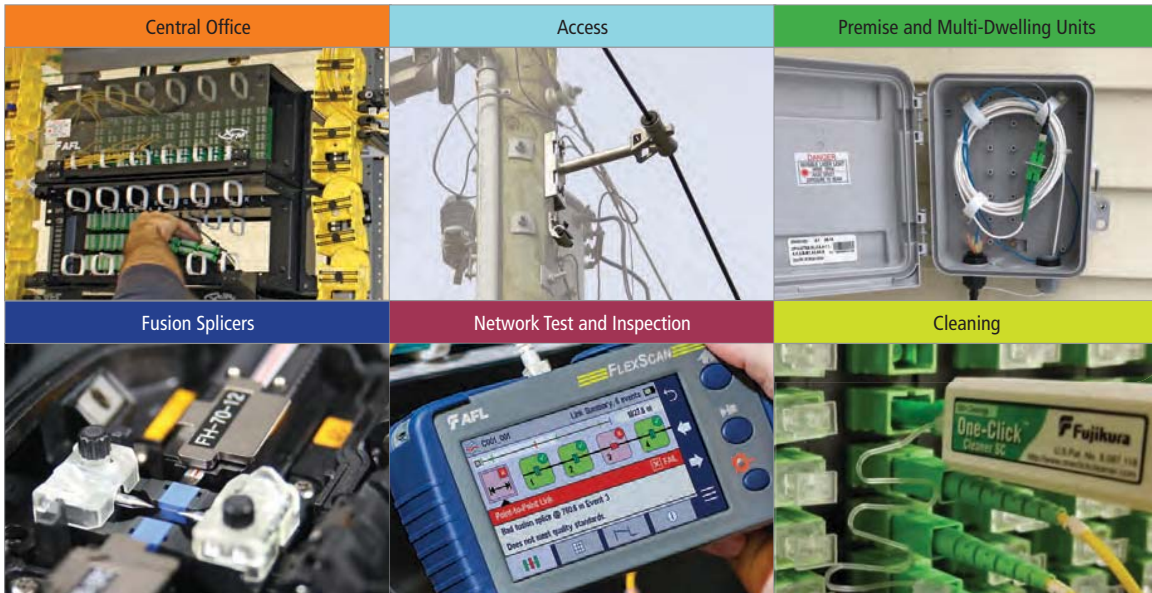

[Back to Table of Contents](#)



## CENTRAL OFFICE

All fiber networks have a start point. At the central office or headend, and possibly at different aggregation points throughout the network, clean and compact fiber management is important. From traditional to high-density rack mount applications to a simple wall-mount panel, AFL has a solution to meet your needs.

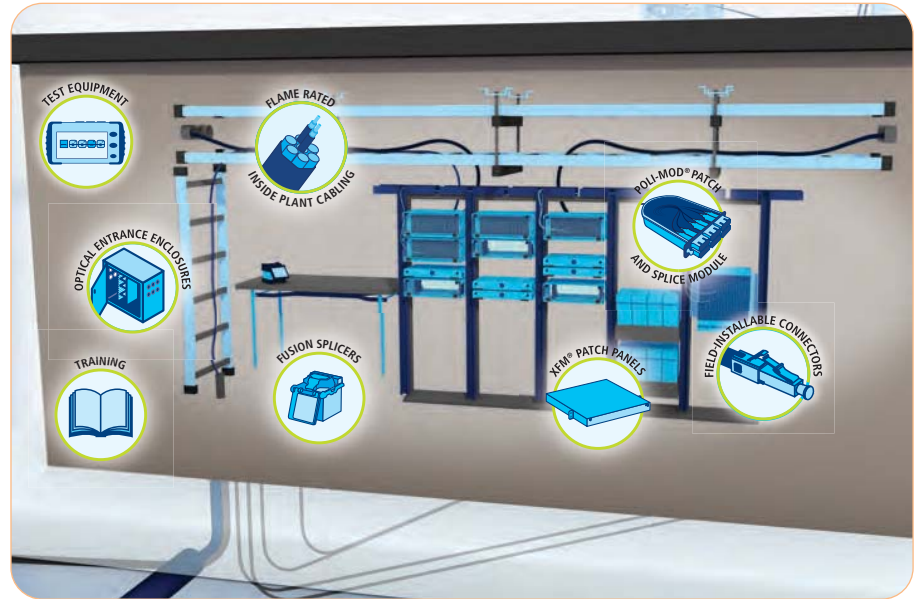

## Xpress Fiber Management® (XFM®) Panels – 1RU, 2RU, 4RU

### Ordering Information

| DESCRIPTION   | MODEL NO.   | AFL NO.     |
|---|-------------|-------------|
| Xpress Fiber Management 1RU Patch Panel, Black, Empty           | XFM-1-U-B-0 | FM002711-BE |
| Xpress Fiber Management 2RU Patch Panel, Black, Empty           | XFM-2-U-B-0 | FM002712-BE |
| Xpress Fiber Management 4RU Patch Panel, Black, Empty           | XFM-4U-B-0  | FM001090-B  |
| Xpress Fiber Management 4RU Patch Panel, Black, Empty, Key Lock | XFM-4U-B-K  | FM001218-B  |



XFM 4RU Patch Panel

[Back to Table of Contents](#)

# Poli-MOD® Patch and Splice Modules

## Common Poli-MOD FTTx Configurations

| AFL NO.            | DESCRIPTION  |
|--------------------|--|
| PM-L-24-ALC-0-S-01 | Poli-MOD loaded with Adapter Plate and Pigtailed, 24 fiber per connector, Angle-polish LC, single-mode, standard fiber arrangement, and 1 Poli-MOD per box |
| PM-L-12-ASC-0-S-01 | Poli-MOD loaded with Adapter Plate and Pigtailed, 12 fiber per connector, Angle-polish SC, single-mode, standard fiber arrangement, and 1 Poli-MOD per box |

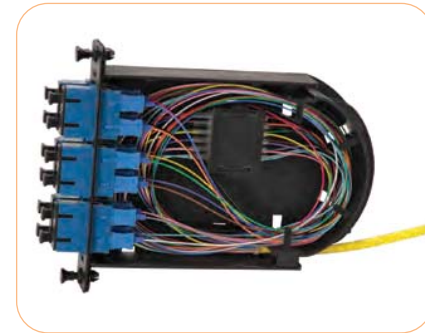

12-Fiber SC/UPC Configuration

## Additional Poli-MOD Configurations

Example: PM-L-12-ASC-0-S-01

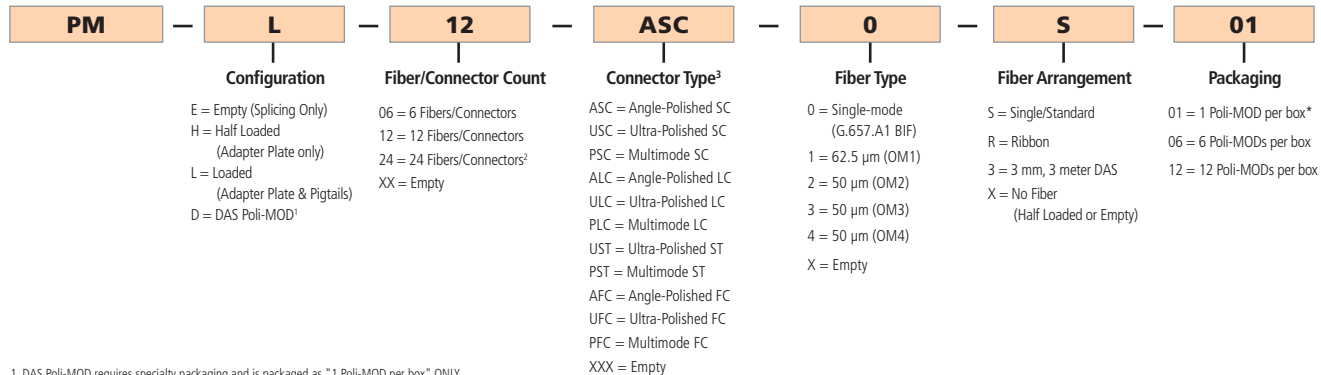

1. DAS Poli-MOD requires specialty packaging and is packaged as "1 Poli-MOD per box" ONLY.  
 2. 24 Fibers/Connectors are only available in a LC Duplex configuration.  
 3. Angle and Ultra-Polished connector types are only available with single-mode fiber configurations.

## Wall-Mount Panels with One, Two or Four LGX® Mounting Positions

### Ordering Information

#### EMPTY

| DESCRIPTION | AFL NO. |
|-------------|---------|
| WME01 Empty | WME01E  |
| WME02 Empty | WME02E  |
| WME04 Empty | WME04E  |



WME01



WME-02



WME04 shown fully loaded

#### HALF LOADED: WME WITH ADAPTER PLATES AND ADAPTERS ONLY

| CONN. TYPE   | NO. OF FIBERS | AFL NO. UPC SM (BLUE) | APC SM (GREEN)       |
|--------------|---------------|-----------------------|----------------------|
| <b>WME01</b> |               |                       |                      |
| SC           | 6             | WME01AS-USCSM-006000  | WME01AS-ASCSM-006000 |
|              | 12            | WME01AS-USCSM-012000  | WME01AS-ASCSM-012000 |
| LC           | 6             | WME01AS-UDLSM-006000  | WME01AS-ADLSM-006000 |
|              | 12            | WME01AS-UDLSM-012000  | WME01AS-ADLSM-012000 |
|              | 24            | WME01AH-UDLSM-024000  | WME01AH-ADLSM-024000 |

|              |    |                      |                      |
|--------------|----|----------------------|----------------------|
| <b>WME02</b> |    |                      |                      |
| SC           | 6  | WME02AS-USCSM-006000 | WME02AS-ASCSM-006000 |
|              | 12 | WME02AS-USCSM-012000 | WME02AS-ASCSM-012000 |
|              | 24 | WME02AH-USFSM-024000 | WME02AH-ASFSM-024000 |
| LC           | 6  | WME02AS-UDLSM-006000 | WME02AS-ADLSM-006000 |
|              | 12 | WME02AS-UDLSM-012000 | WME02AS-ADLSM-012000 |
|              | 24 | WME02AH-UDLSM-024000 | WME02AH-ADLSM-024000 |

|              |    |                      |                      |
|--------------|----|----------------------|----------------------|
| <b>WME04</b> |    |                      |                      |
| SC           | 24 | WME04AS-USCSM-024000 | WME04AS-ASCSM-024000 |
|              | 48 | WME04AH-USFSM-048000 | WME04AH-ASFSM-048000 |
| LC           | 24 | WME04AS-UDLSM-024000 | WME04AS-ADLSM-024000 |
|              | 48 | WME04AH-UDLSM-048000 | WME04AH-ADLSM-048000 |

#### LOADED: WME WITH ADAPTER PLATES/ADAPTERS/SPLICE CHIP/PIGTAIL (900 μm TIGHT BUFFERED FIBERS 3 METERS IN LENGTH)

| CONN. TYPE   | NO. OF FIBERS | AFL NO. UPC SM (BLUE) | APC SM (GREEN)       |
|--------------|---------------|-----------------------|----------------------|
| <b>WME01</b> |               |                       |                      |
| SC           | 6             | WME01FS-USCSM-0061C0  | WME01FS-ASCSM-0061C0 |
|              | 12            | WME01FS-USCSM-0121C0  | WME01FS-ASCSM-0121C0 |
| LC           | 6             | WME01FS-UDLSM-0061C0  | WME01FS-ADLSM-0061C0 |
|              | 12            | WME01FS-UDLSM-0121C0  | WME01FS-ADLSM-0121C0 |
|              | 24            | WME01FH-UDLSM-0241C0  | WME01FH-ADLSM-0241C0 |

|              |    |                      |                      |
|--------------|----|----------------------|----------------------|
| <b>WME02</b> |    |                      |                      |
| SC           | 6  | WME02FS-USCSM-006110 | WME02FS-ASCSM-006110 |
|              | 12 | WME02FS-USCSM-012110 | WME02FS-ASCSM-012110 |
|              | 24 | WME02FH-USFSM-024120 | WME02FH-ASFSM-024120 |
| LC           | 6  | WME02FS-UDLSM-006110 | WME02FS-ADLSM-006110 |
|              | 12 | WME02FS-UDLSM-012110 | WME02FS-ADLSM-012110 |
|              | 24 | WME02FH-UDLSM-024120 | WME02FH-ADLSM-024120 |

|              |    |                      |                      |
|--------------|----|----------------------|----------------------|
| <b>WME04</b> |    |                      |                      |
| SC           | 24 | WME04FS-USCSM-024120 | WME04FS-ASCSM-024120 |
|              | 48 | WME04FH-USFSM-048140 | WME04FH-ASFSM-048140 |
| LC           | 24 | WME04FS-UDLSM-024120 | WME04FS-ADLSM-024120 |
|              | 48 | WME04FH-UDLSM-048140 | WME04FH-ADLSM-048140 |

[Back to Table of Contents](#)

## ACCESS

Beyond the central office, the bulk of a FTTx network is in the access. Whether aerial or underground, there are a variety of cable designs and technologies to choose from for your application. Splice enclosures are also capable of strand mount, pole mount, and underground placement. For FTTx PON designs, optical splitting is typically done at the central office, in exterior distribution cabinets, or in the splice enclosures.

Last mile deployment has been increasingly relying on multiport terminals and hardened drop cables for quick and easy subscriber connections.

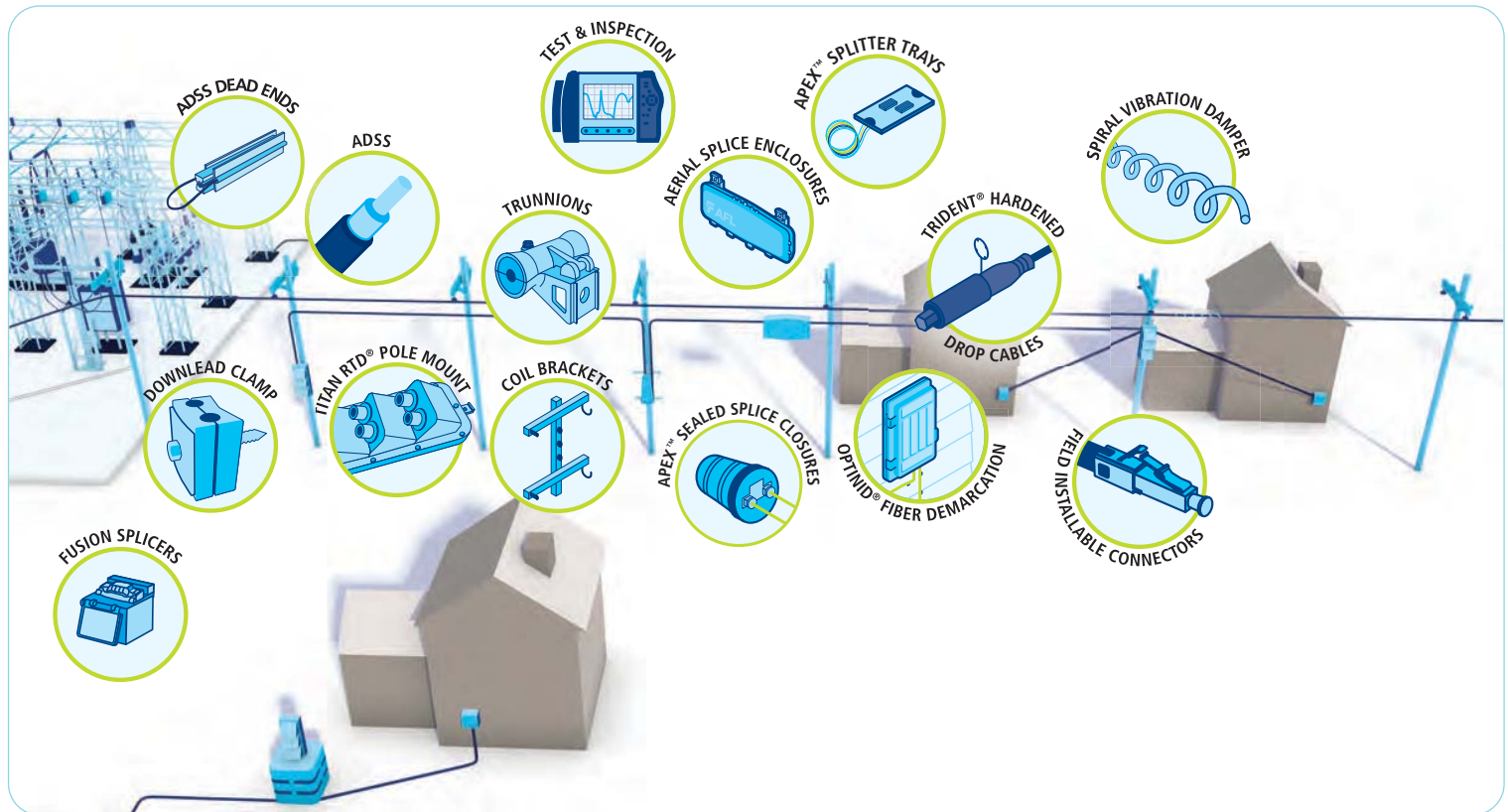

## ADSS Cable and Hardware

ADSS fiber cables can provide advantages over traditional strand and lash fiber networks in many cases. Some of these advantages to ADSS cables include:

- No metallic components – can install in supply space and grounding is not required
- Little to no “make ready” cost
- Lower hardware costs
- Speed and ease of installation
- Minimal long-term maintenance
- Longer expected design life

In many scenarios, these advantages lead to a lower total cost.

All-dielectric self-supporting (ADSS) cable design packages are available with common diameter range taking hardware components. These packages range in strength capability. ADSS cables can be used for span lengths greater than 6000', so strength capability in distribution environments typical for FTTx applications is of no concern. To find the most cost effective ADSS design for a FTTx network, the loading requirements should be reviewed. The loading requirements can be determined using the maximum pole-to-pole span length and the loading condition that is defined by the National Electric Safety Code (NESC) based on the location of the project.

Please contact AFL's Application Engineering group to learn more about our FTTx ADSS offerings, 1-864-433-0333.

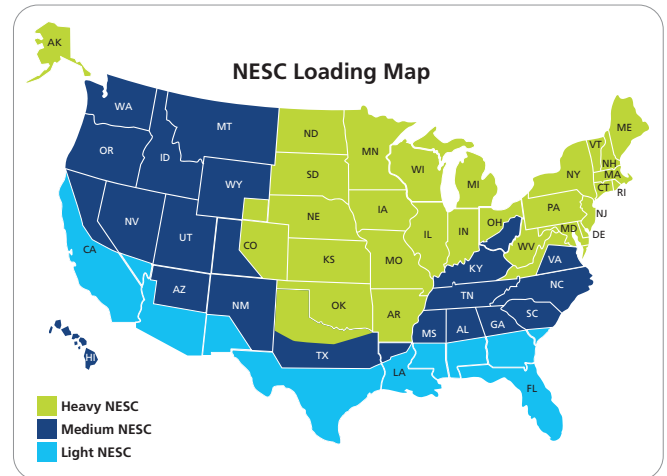
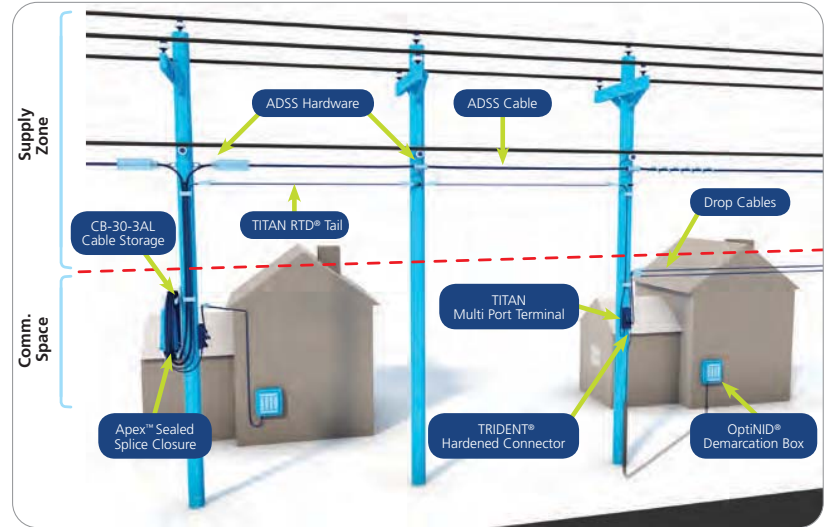

## ADSS Suspensions

The AFL ADSS suspension units can be used for line angle changes up to 30 degrees. This hardware can be useful when a line angle exceeds the maximum 22 degrees for the trunnion to avoid using a double dead end.

| NESC LOADING CONDITION |        |       |
|------------------------|--------|-------|
| HEAVY                  | MEDIUM | LIGHT |
| 600'                   | 900'   | 1200' |



## Trunnions

The AFL trunnion clamp can be used up to 22-degree line angle change. The trunnion can be used to string the ADSS cable during install, eliminating the need of a sheave at that point.

| NESC LOADING CONDITION |       |        |       |
|------------------------|-------|--------|-------|
| DIAMETER               | HEAVY | MEDIUM | LIGHT |
| <0.875"                | 600'  | 850'   | 1200' |
| >0.875"                | 500'  | 750'   | 950'  |



Single Trunnion Cable Support



Double Trunnion Cable Support

Double trunnion suspensions are also available to allow for two cables at one pole penetration point.

## Vibration Dampers

Vibration dampers are used to minimize cable vibration. They are typically recommended for span lengths greater than 350 feet but are dependent on the installed tension of the cable. Contact AFL for specific recommendations on vibration dampers.



Spiral Vibration Damper on ADSS Cable

## Slack Storage

Storing slack cable at splice locations and throughout a FTTx network is critical. There are two primary methods for slack storage, on the pole (coil bracket) and in-line with the cable (fiber storage units).

### Coil Bracket

The CB-30-3AL is 30 inches wide and stores up to 80 ft. total length of ADSS cable. It is used with AFL's Apex™ Sealed Splice Closures ([see page 15](#)). The CB-30-3AL coil bracket can be bolted or banded to the structure.

### Splice Enclosure Mounting Bracket

Used for quick and simple attachment of the Apex sealed splice enclosures to the CB-30-3AL coil bracket.

### Ordering Information

| MODEL   | AFL NO.   |
|---|-----------|
| CB-30-3AL ADSS Coil Storage Bracket for Apex Sealed Splice Closures | CB-30-3AL |
| Mounting Bracket for Apex Sealed Splice Closure                     | AX-BR30   |

### Standoff Bracket for ADSS Hardware Clamps

The Standoff Bracket positions the AFL ADSS trunnion or AFL ADSS suspension 14" off of structure.

### Specifications

| PARAMETER   | VERTICAL  | HORIZONTAL |
|-------------|-----------|------------|
| Load Rating | 1,250 lbs | 1,250 lbs  |

### Ordering Information

| AFL NO. | DESCRIPTION  |
|---------|--|
| DTSB12  | 14" Standoff Bracket, for use with AFL's ATGN Trunnion Clamp or ASN Suspension Clamp on ADSS Fiber Optic Cable |



Coil Bracket holds excess ADSS cable



Standoff Bracket with AFL ATGN Single Trunnion

## Fiber Storage Units

Fiber Storage Units (FSU) are used to conveniently store an extra length of cable along the ADSS cable run for later use.

### Specifications

| PARAMETER             | FOSP-ADSS-12 | FOSP-ADSS-17 |
|-----------------------|--------------|--------------|
| Nominal Channel Width | 0.625"       | 1.00"        |
| Minimum Bend Diameter | 12"          | 17.5"        |

### Ordering Information

| DESCRIPTION  | FOSP-ADSS-12 | FOSP-ADSS-17 |
|--------------|--------------|--------------|
| FOS ADSS Kit | FA000049     | FA000050     |

Kits contain one pair of FOSP and two sets of hanger brackets.



### Typical Installation Diagram

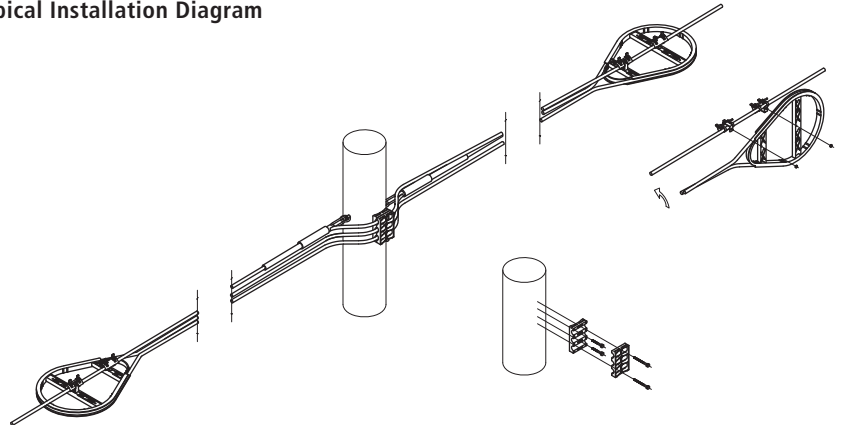



## Download Clamps

Download clamps are used to secure the cable to the pole. Typically, one clamp is used every 5-8 feet down the length of the pole.

Contact AFL for ordering information.



## Flat Drop Download

The Flat Drop Cable Download accessory provides a means of suspending multiple flat drop cables to structures where termination is undesirable. The accessory can also be used in download applications to guide flat drop cables from the top of the structure to the splice box.

### Ordering Information

| AFL NO.  | FLAT DROP CAPACITY | HARDWARE INCLUDED      |
|----------|--------------------|------------------------|
| FDCT-4   | up to 4            | —                      |
| FDCT-12  | up to 12           | —                      |
| FDCT-8   | up to 8            | —                      |
| FDCT-4D  | up to 4            | Lag screw hardware kit |
| FDCT-12D | up to 12           | Lag screw hardware kit |

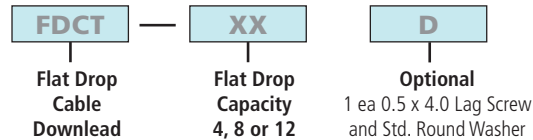

## Temporary Grip

Temporary Grips are used in stringing the ADSS during sagging and where it is necessary to make short term catch on the ADSS. The Temporary grip for ADSS is a high strength aluminum body designed to hold 2,500 pounds or 50% of MRCL of the cable. Tapered wedges are machined specifically to the cable diameter.

### Ordering Information



[Back to Table of Contents](#)

## Underground Cable

For underground applications or aerial strand and lash applications, the following fiber cables can be used.

### LMHD OSP MicroCore® Cable

#### Physical and Mechanical Data

| LMHD-SERIES<br>AFL NO.* | FIBER<br>COUNT | FIBERS/<br>NUMBER OF<br>TUBES** | DIAMETER     |             | WEIGHT    | MAXIMUM TENSILE LOAD  |              | MINIMUM BEND RADIUS |              |
|-------------------------|----------------|---------------------------------|--------------|-------------|-----------|-----------------------|--------------|---------------------|--------------|
|                         |                |                                 | INCHES (MM)  | INCHES (MM) |           | LBS/1000FT<br>(KG/KM) | INSTALLATION | OPERATION           | INSTALLATION |
| LM012xC6201#1           | 12             | 12/1 (5 fillers)                | 0.359 (9.1)  | 0.512 (13)  | 42 (64)   | 600 (2670)            | 180 (801)    | 7.5 (19)            | 5.5 (14)     |
| LM024xC6201#1           | 24             | 12/2 (4 fillers)                | 0.359 (9.1)  | 0.512 (13)  | 43 (65)   | 600 (2670)            | 180 (801)    | 7.5 (19)            | 5.5 (14)     |
| LM048xC6201#1           | 48             | 12/4 (2 fillers)                | 0.359 (9.1)  | 0.512 (13)  | 44 (67)   | 600 (2670)            | 180 (801)    | 7.5 (19)            | 5.5 (14)     |
| LM072xC6201#1           | 72             | 12/6                            | 0.359 (9.1)  | 0.512 (13)  | 45 (69)   | 600 (2670)            | 180 (801)    | 7.5 (19)            | 5.5 (14)     |
| LM096xO6201#1           | 96             | 24/4 (2 fillers)                | 0.390 (9.9)  | 0.512 (13)  | 52 (79)   | 600 (2670)            | 180 (801)    | 8 (20)              | 6 (15)       |
| LM144xO6201#1           | 144            | 24/6                            | 0.390 (9.9)  | 0.512 (13)  | 57 (85)   | 600 (2670)            | 180 (801)    | 8 (20)              | 6 (15)       |
| LM288xR6201#1           | 288            | 48/6                            | 0.481 (12.2) | 0.630 (16)  | 82 (125)  | 600 (2670)            | 180 (801)    | 10 (25)             | 7.5 (19)     |
| LM432xO1201#1           | 432            | 24/18                           | 0.567 (14.4) | 0.787 (20)  | 112 (167) | 600 (2670)            | 180 (801)    | 11.5 (29)           | 9 (22)       |

\* Replace # with "N" for all-dielectric cable or "T" for toneable option.

"x" denotes fiber type. See Optical Fibers Options table below.

\*\* Fibers are arranged in 12-fiber sets. Each set is identified by colored binder threads.

#### Optical Fiber Options

| FIBER TYPE           | "X" | STANDARD              | MODE FIELD DIAMETER | ATTENUATION |         |
|----------------------|-----|-----------------------|---------------------|-------------|---------|
|                      |     |                       |                     | 1300 nm     | 1550 nm |
| Single-mode          | 9   | ITU-T G.652D / 657.A1 | 9.2 µm nominal      | 0.35        | 0.25    |
| Corning SMF-28 Ultra | AZ  | ITU-T G.652D / 657.A1 | 9.2 µm nominal      | 0.35        | 0.25    |

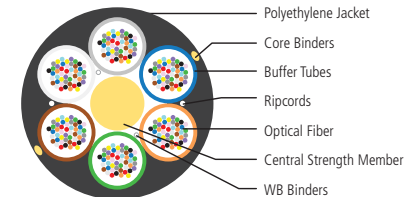

[Back to Table of Contents](#)

## Wrapping Tube Cable with SpiderWeb Ribbon® (SWR®) Technology

### Mechanical Data—Non-Armored

| DESCRIPTION                | FIBER COUNT | BINDER UNIT | NOMINAL DIAMETER | WEIGHT    | SHORT TERM / INSTALLATION |                          | LONG TERM / STORAGE /STATIC |                          |
|----------------------------|-------------|-------------|------------------|-----------|---------------------------|--------------------------|-----------------------------|--------------------------|
|                            |             |             | INCHES (MM)      |           | LBS/1,000 FT (KG/KM)      | MAX TENSILE LOAD LBS (N) | MIN BEND RADIUS INCHES (MM) | MAX TENSILE LOAD LBS (N) |
| LWSE-144-9-C-144-1-00N1D   | 144         | 1 X 144F    | 0.41 (10.5)      | 57 (85)   | 607 (2700)                | 9 (229)                  | 182 (810)                   | 6 (158)                  |
| LWSE-288-9-C-72-4-00N1D    | 288         | 4 X 72F     | 0.47 (12.0)      | 71 (105)  | 607 (2700)                | 10 (254)                 | 182 (810)                   | 7 (180)                  |
| LWSE-432-9-C-72-6-00N1D    | 432         | 6 X 72F     | 0.53 (13.5)      | 91 (135)  | 607 (2700)                | 11 (270)                 | 182 (810)                   | 8 (203)                  |
| LWSE-576-9-C-72-8-00N1D    | 576         | 8 X 72F     | 0.59 (15.0)      | 111 (165) | 607 (2700)                | 12 (300)                 | 182 (810)                   | 9 (225)                  |
| LWSE-864-9-C-72-12-00N1D   | 864         | 12 X 72F    | 0.69 (17.5)      | 145 (215) | 607 (2700)                | 14 (350)                 | 182 (810)                   | 11 (279)                 |
| LWSE-1152-K-C-144-8-00N1D  | 1152        | 8 X 144F    | 0.73 (18.5)      | 161 (240) | 607 (2700)                | 15 (370)                 | 182 (810)                   | 11 (279)                 |
| LWSE-1728-K-C-144-12-00N1D | 1728        | 12 X 144F   | 0.91 (23.0)      | 242 (360) | 607 (2700)                | 18 (460)                 | 182 (810)                   | 14 (345)                 |
| LWSE-3456-K-C-144-24-00N1D | 3456        | 24 X 144F   | 1.20 (30.5)      | 403 (600) | 607 (2700)                | 24 (610)                 | 182 (810)                   | 18 (458)                 |

### Mechanical Data—OSP Armored

| DESCRIPTION                | FIBER COUNT | BINDER UNIT | NOMINAL DIAMETER | WEIGHT    | SHORT TERM / INSTALLATION |                          | LONG TERM / STORAGE /STATIC |                          |
|----------------------------|-------------|-------------|------------------|-----------|---------------------------|--------------------------|-----------------------------|--------------------------|
|                            |             |             | INCHES (MM)      |           | LBS/1,000 FT (KG/KM)      | MAX TENSILE LOAD LBS (N) | MIN BEND RADIUS INCHES (MM) | MAX TENSILE LOAD LBS (N) |
| LWSE-144-9-C-144-1-10S1D   | 144         | 1 X 144F    | 0.63 (16.0)      | 148 (220) | 607 (2700)                | 13 (320)                 | 182 (810)                   | 10 (254)                 |
| LWSE-288-9-C-72-4-10S1D    | 288         | 4 X 72F     | 0.69 (17.5)      | 172 (255) | 607 (2700)                | 14 (350)                 | 182 (810)                   | 11 (279)                 |
| LWSE-432-9-C-72-6-10S1D    | 432         | 6 X 72F     | 0.75 (19.0)      | 202 (300) | 607 (2700)                | 15 (380)                 | 182 (810)                   | 11 (285)                 |
| LWSE-576-9-C-72-8-10S1D    | 576         | 8 X 72F     | 0.81 (20.5)      | 235 (350) | 607 (2700)                | 16 (410)                 | 182 (810)                   | 12 (308)                 |
| LWSE-864-9-C-72-12-10S1D   | 864         | 12 X 72F    | 0.91 (23.0)      | 286 (425) | 607 (2700)                | 18 (460)                 | 182 (810)                   | 14 (345)                 |
| LWSE-1728-K-C-144-12-10S1D | 1728*       | 12 X 144F   | 1.14 (29.0)      | 410 (610) | 607 (2700)                | 23 (580)                 | 182 (810)                   | 17 (435)                 |

\* NOTE: Modified temperature performance

### Optical Fiber

| FIBER COUNT             | FIBER DESIGNATOR          | MFD          | MAXIMUM ATTENUATION (CABLED)<br>dB/km |         |         |
|-------------------------|---------------------------|--------------|---------------------------------------|---------|---------|
|                         |                           |              | 1310 NM                               | 1383 NM | 1550 NM |
| 144, 288, 432, 576, 864 | 9 (ITU-T G.652D/G.657.A1) | 9.2 ± 0.4 μm | ≤0.40                                 | ≤0.40   | ≤0.30   |
| 1152, 1728, 3456        | K (ITU-T G.652D/G.657.A1) | 8.6 ± 0.4 μm | ≤0.40                                 | ≤0.40   | ≤0.30   |

[Back to Table of Contents](#)

## Sealed (Underground and Pole Mount)

AFL's new Apex™ sealed splice closures are used for underground applications and in pole-mount applications typically using a coil bracket (CB-30-3AL).

The Apex X-2 and X-2S are sealed splice closures designed for protecting optical fiber splices in both above- or below-grade applications in a butt configuration. Cables are sealed by a unique wedge system spaced evenly around the circumference of the closure's base. Each cable seal is opened by a press-to-release lever and sealing is completed by actuating a single screw for each cable. Each cable is sealed individually, ensuring original craftsmanship when cables may be added at a later date. Up to 6 splice trays are attached and hinge off a central organizer. A plastic slack storage basket resides underneath the trays with ample tie down points for managing tube and fiber slack.



### Apex Sealed Splice Closure Summary Specifications

| DESCRIPTION  | MODEL                                    |  |
|--|--|--|
|  | X-2                                      | X-2S                                     |
| Splice Capacity – Single, Mass (SWR®), Mass (Standard) | 432, 3456, 864                           | 216, 1728, 432                           |
| Splice Tray Capacity                                   | 6  | 6  |
| Cable Diameter, Single Port, in. (mm)                  | 0.40" – 1.10" (10.0 – 28.0)              | 0.40" – 1.10" (10.0 – 28.0)              |
| Cable Diameter, Multi-Drop Kit, in. (mm)               | 0.20" – 0.39" (5.0 - 9.9) or flat drop   | 0.20" – 0.39" (5.0 - 9.9) or flat drop   |
| Dimensions – (L x D) in. (cm)                          | 25.0" x 12.0" (64 x 30)                  | 20.0" x 12.0" (51 x 30)                  |
| Weight, No Trays – lbs (kg)                            | 25 (11.3)                                | 22 (10)                                  |
| Application  | Direct Bury, Handhole, Aerial, Pole/Wall | Direct Bury, Handhole, Aerial, Pole/Wall |



[Back to Table of Contents](#)

## Apex™ Sealed Splice Closures

The Apex X-2 is capable of up to 432 single fusion, 864 mass fusion with standard ribbon, or 3,456 using 200 µm mass fusion with rollable ribbon fiber types (such as AFL's SpiderWeb Ribbon® (SWR®)). If using 250 µm fiber, 1,728 fibers is the maximum fiber count.

The Apex X-2S is capable of up to 216 single fusion, 432 mass fusion with standard ribbon, or 1,728 using 200 µm mass fusion with rollable ribbon fiber types (SWR). If using 250 µm fiber, 864 fibers is the maximum fiber count.

Refer to the [Apex X-2](#) and [Apex X-2S](#) specification sheets for more information.

### Ordering Information – X-2

|                      |                     |                      |   |                        |  |                              |   |
|----------------------|---------------------|----------------------|---|------------------------|--|------------------------------|---|
| <b>AX</b>            | <b>2</b>            | <b>B</b>             | <b>L</b>  | <b>0</b>               | <b>2</b>                                 | <b>6</b>                     | <b>B</b>  |
| <b>APEX CLOSURES</b> | <b>CLOSURE SIZE</b> | <b>BASKET TYPE</b>   | <b>TRAY TYPE</b>  | <b>NUMBER OF TRAYS</b> | <b>CABLE STRAIN RELIEF HARDWARE KITS</b> | <b>NUMBER OF GROUND LUGS</b> | <b>INNER BASKET</b>                             |
|                      | 2 = X-2 Size        | B = X-2 Sized Basket | X = No preinstalled tray<br>L = X-2 Tray Loaded with splice modules<br>E = X-2 Tray empty | 0<br>1<br>6            | 2<br>4<br>6                              | 0<br>2<br>6                  | X = No Inner Basket<br>B = Include Inner Basket |

### Ordering Information – X-2S

|                      |                     |                       |   |                        |  |                              |                     |
|----------------------|---------------------|-----------------------|---|------------------------|--|------------------------------|---------------------|
| <b>AX</b>            | <b>2</b>            | <b>B</b>              | <b>L</b>  | <b>0</b>               | <b>2</b>                                 | <b>6</b>                     | <b>X</b>            |
| <b>APEX CLOSURES</b> | <b>CLOSURE SIZE</b> | <b>BASKET TYPE</b>    | <b>TRAY TYPE</b>  | <b>NUMBER OF TRAYS</b> | <b>CABLE STRAIN RELIEF HARDWARE KITS</b> | <b>NUMBER OF GROUND LUGS</b> | <b>INNER BASKET</b> |
|                      | 2S = X-2S Size      | B = X-2S Sized Basket | X = No preinstalled tray<br>L = X-2S Tray Loaded with splice modules<br>E = X-2S Tray empty | 0<br>1<br>6            | 2<br>4<br>6                              | 0<br>2<br>6                  | X = No Inner Basket |

## Apex™ Splitter Trays

Passive optical splitters, or PLCs (Planar Lightwave Circuits), can be provided preinstalled into the Apex X-2S and Apex X-2 splice trays. PLCs can either be installed and splice within the same tray, or provided with a separate dedicated tray for splicing, with fibers routed between trays using protective tubing. A third option provides one additional tray to separate input and output fiber splicing.

### Ordering Information

| DESCRIPTION   | SPLIT RATIO | AFL NO.          |
|---|-------------|------------------|
| <b>APEX X-2S</b>  |             |                  |
| X-2S Tray with Two Splice Modules, (1) 1x4 PLC Splitter   | 1x4         | AX-TRAY-2S-14-1  |
| X-2S Tray with Two Splice Modules, (1) 1x8 PLC Splitter   | 1x8         | AX-TRAY-2S-18-1  |
| X-2S Tray with Two Splice Modules, (1) 1x16 PLC Splitter  | 1x16        | AX-TRAY-2S-116-1 |
| X-2S Tray with Two Splice Modules, (1) 1x32 PLC Splitter  | 1x32        | AX-TRAY-2S-132-1 |
| X-2S Tray with (1) 1x4 PLC Splitter and Separate Splicing Tray with Two Splice Modules          | 1x4         | AX-TRAY-2S-14-2  |
| X-2S Tray with (1) 1x8 PLC Splitter and Separate Splicing Tray with Two Splice Modules          | 1x8         | AX-TRAY-2S-18-2  |
| X-2S Tray with (1) 1x16 PLC Splitter and Separate Splicing Tray with Two Splice Modules         | 1x16        | AX-TRAY-2S-116-2 |
| X-2S Tray with (1) 1x32 PLC Splitter and Separate Splicing Tray with Two Splice Modules         | 1x32        | AX-TRAY-2S-132-2 |
| X-2S Tray with (1) 1x4 PLC Splitter and 2 Separate Splicing Trays with Two Splice Modules each  | 1x4         | AX-TRAY-2S-14-3  |
| X-2S Tray with (1) 1x8 PLC Splitter and 2 Separate Splicing Trays with Two Splice Modules each  | 1x8         | AX-TRAY-2S-18-3  |
| X-2S Tray with (1) 1x16 PLC Splitter and 2 Separate Splicing Trays with Two Splice Modules each | 1x16        | AX-TRAY-2S-116-3 |
| X-2S Tray with (1) 1x32 PLC Splitter and 2 Separate Splicing Trays with Two Splice Modules each | 1x32        | AX-TRAY-2S-132-3 |
| <b>APEX X-2</b>   |             |                  |
| X-2 Tray with Four Splice Modules, (1) 1x4 PLC Splitter   | 1x4         | AX-TRAY-2-14-1   |
| X-2 Tray with Four Splice Modules, (1) 1x8 PLC Splitter   | 1x8         | AX-TRAY-2-18-1   |
| X-2 Tray with Four Splice Modules, (1) 1x16 PLC Splitter  | 1x16        | AX-TRAY-2-116-1  |
| X-2 Tray with Four Splice Modules, (1) 1x32 PLC Splitter  | 1x32        | AX-TRAY-2-132-1  |
| X-2 Tray with (1) 1x4 PLC Splitter and Separate Splicing Tray with Four Splice Modules          | 1x4         | AX-TRAY-2-14-2   |
| X-2 Tray with (1) 1x8 PLC Splitter and Separate Splicing Tray with Four Splice Modules          | 1x8         | AX-TRAY-2-18-2   |
| X-2 Tray with (1) 1x16 PLC Splitter and Separate Splicing Tray with Four Splice Modules         | 1x16        | AX-TRAY-2-116-2  |
| X-2 Tray with (1) 1x32 PLC Splitter and Separate Splicing Tray with Four Splice Modules         | 1x32        | AX-TRAY-2-132-2  |
| X-2 Tray with (1) 1x4 PLC Splitter and 2 Separate Splicing Trays with Four Splice Modules each  | 1x4         | AX-TRAY-2-14-3   |
| X-2 Tray with (1) 1x8 PLC Splitter and 2 Separate Splicing Trays with Four Splice Modules each  | 1x8         | AX-TRAY-2-18-3   |
| X-2 Tray with (1) 1x16 PLC Splitter and 2 Separate Splicing Trays with Four Splice Modules each | 1x16        | AX-TRAY-2-116-3  |
| X-2 Tray with (1) 1x32 PLC Splitter and 2 Separate Splicing Trays with Four Splice Modules each | 1x32        | AX-TRAY-2-132-3  |

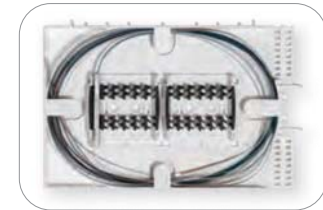

Apex X-2S Splitter Tray

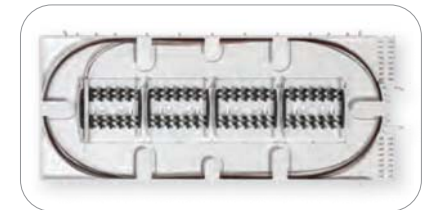

Apex X-2 Splitter Tray

Ordering Information

| DESCRIPTION   | TRAY CAPACITY |      | AFL NO.        |
|---|---------------|------|----------------|
|   | SINGLE        | MASS |                |
| <b>SPLICE TRAYS AND SPLICE MODULES</b>  |               |      |                |
| X-2S Tray Loaded with One Splice Module   | 18            | 72   | AX-TRAY-2S-1   |
| X-2S Tray Fully Loaded with Two Splice Modules (288 fibers per tray only recommended for rollable ribbon, e.g. AFL SWR) | 36            | 288  | AX-TRAY-2S-2   |
| Additional splice module (18 single fusion triple stacked, 12 mass fusion double stacked, 6 mechanical) – Pack of 20    | –             | –    | AX-TRAY-MOD-20 |
| X-2S Tray Empty   | –             | –    | AX-TRAY-2S-E   |

\* 288 fibers per tray with mass fusion double-stacking 1728 total closure capacity) only recommended for 200 um type rollable ribbon. For 250 um, cut capacity in half with single-stacking.

| DESCRIPTION  | AFL NO.        |
|--|----------------|
| <b>SLACK STORAGE BASKET</b>                        |                |
| Replacement slack storage basket tabs – Pack of 25 | AX-KIT-BTAB-25 |

| DESCRIPTION   | AFL NO.             |
|---|---------------------|
| <b>INSTALLATION ACCESSORIES AND KITS</b>  |                     |
| Aerial strand mount hanger kit  | AX-KIT-AERIAL-1     |
| Pole/wall mount kit   | AX-BR30             |
| 1/4" Colored Mesh Transition Tubing, 250' Spool   | AX-KIT-TUBE-014-XX* |
| Single Cable Strain Relief/Attachment Kit   | AX-KIT-CBLSTRN      |
| Multi-Drop Cable Entry Kit<br>(fits up to 4 cables 0.20" to 0.39" in diameter or flat drop cable)               | AX-KIT-DROP-4       |
| X-2 and X-2S Dome to Base O-Ring Replacement Kit  | AX-KIT-ORING-2      |
| X-2 and X-2S Dome to Base Locking Ring Clamp Replacement Kit  | AX-KIT-CLAMP-2      |
| X-2 and X-2S Wedge Replacement Kit  | AX-KIT-WEDGE-2      |
| X-2 and X-2S Installation Stand   | FC104649            |
| Apex X-2 and X-2S Inner Base Gel Replacement Kit  | AX-KIT-GEL-2        |
| Apex X-2S Dome Replacement Kit  | AX-KIT-DOME-2S      |
| WTC-SWR® Bundle Splice Tray Retention Kit - Includes 25 foam grommets for retaining SWR bundles to splice trays | HW000406            |
| Silicone Spiral Wrap, 5.5 Foot Length   | FC001657            |
| Velcro, 75 Foot Length Roll – For securing SWR bundles in the slack basket                                      | FC001759            |

\* Replace "XX" with any of the following for colors per the TIA-598 color code – BL, OR, GR, BR, SL, WH, RD, BK, YL, VI, RS or AQ

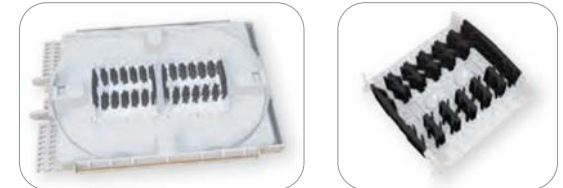

Apex X-2S Splice Tray and Splice Module



Apex X-2S Mounted on Installation Stand

Ordering Information

| DESCRIPTION   | TRAY CAPACITY |      | AFL NO.        |
|---|---------------|------|----------------|
|   | SINGLE        | MASS |                |
| <b>SPLICE TRAYS AND SPLICE MODULES</b>  |               |      |                |
| X-2 Tray Loaded with Two Splice Modules   | 36            | 144  | AX-TRAY-2-2    |
| X-2 Tray Fully Loaded with Four Splice Modules (576 fibers per tray only recommended for rollable ribbon, e.g. AFL SWR) | 72            | 576  | AX-TRAY-2-4    |
| Additional splice module (18 single fusion triple stacked, 12 mass fusion double stacked, 6 mechanical) – Pack of 20    | -             | -    | AX-TRAY-MOD-20 |
| X-2 Tray Empty  | -             | -    | AX-TRAY-2-E    |

\* 576 fibers per tray with mass fusion double-stacking (3456 total closure capacity) only recommended for 200 µm type rollable ribbon. For 250 µm, cut capacity in half with single-stacking

| DESCRIPTION  | AFL NO.          |
|--|------------------|
| <b>SLACK STORAGE BASKET</b>  |                  |
| Clear segmented basket for X-2. Can be used in combination with the basket cover | AX-KIT-SBASKET-2 |
| Replacement slack storage basket tabs – Pack of 25                               | AX-KIT-BTAB-25   |

| DESCRIPTION  | AFL NO.             |
|--|---------------------|
| <b>INSTALLATION ACCESSORIES AND KITS</b>   |                     |
| Aerial strand mount hanger kit   | AX-KIT-AERIAL-1     |
| Pole/wall mount kit  | AX-BR30             |
| 1/4" Colored Mesh Transition Tubing, 250' Spool  | AX-KIT-TUBE-014-XX* |
| Single Cable Strain Relief/Attachment Kit  | AX-KIT-CBLSTRN      |
| Multi-Drop Cable Entry Kit   | AX-KIT-DROP-4       |
| (fits up to 4 cables 0.20" to 0.39" in diameter or flat drop cable)  |                     |
| X-2 and X-2S Dome to Base O-Ring Replacement Kit   | AX-KIT-ORING-2      |
| X-2 and X-2S Dome to Base Locking Ring Clamp Replacement Kit   | AX-KIT-CLAMP-2      |
| X-2 and X-2S Wedge Replacement Kit   | AX-KIT-WEDGE-2      |
| X-2 and X-2S Installation Stand  | FC104649            |
| Apex X-2 and X-2S Inner Base Gel Replacement Kit   | AX-KIT-GEL-2        |
| Apex X-2 Dome Replacement Kit  | AX-KIT-DOME-2       |
| WTC-SWR Bundle Splice Tray Retention Kit - Includes 25 foam grommets for retaining SWR bundles to splice trays | HW000406            |
| Silicone Spiral Wrap, 5.5 Foot Length  | FC001657            |
| Velcro, 75 Foot Length Roll – For securing SWR bundles in the slack basket                                     | FC001759            |

\* Replace "XX" with any of the following for colors per the TIA-598 color code – BL, OR, GR, BR, SL, WH, RD, BK, YL, VI, RS or AQ

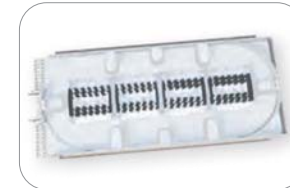

Apex X-2 Splice Tray



Apex X-2 Splice Module



Clear Segmented Basket



Replacement Slack Storage Basket



Foam Grommets



Silicone Spiral Wrap



## Aerial (On Strand)

AFL aerial weathertight closures are used in aerial, in-line applications. For ADSS, the closure is mounted onto the dead end. For strand and lash cables, the closure is mounted to the strand.

### Aerial Closure Summary Specifications

| PARAMETER   | LG-410-U-0   | LG-420-U-0   | LG-500-U-0   | LG-600-U-0  |
|---|--|--|--|---|
| Splice Capacity (Max.) - Single, Mass, Mechanical | 144, 432, 36   | 12, 48, 12   | 144, 432, 36   | 384, 1152, 96   |
| Splice Tray Capacity - Single, Mass               | 4, 2   | n/a, n/a   | 4, 2   | 12, 8, 8  |
| Cable Ports                                       | 4-8  | 4-6  | 4-8  | 6 (3 per end)   |
| Cable Entrance                                    | In-line, Butt  | In-line (taut sheath)  | In-line, Butt  | In-line, Butt   |
| Cable Sizes (O.D.)                                | 4 @ 0.3-0.82"  | 4 @ 0.3-0.82"  | 4 @ 0.3-0.82"  | 6 @ 0.44 - 1.0"   |
|   | Up to 8 with Dual Grommet Kits<br>4 @ 0.27-0.53"<br>4 @ 0.38-0.70" | Up to 6 with Dual Grommet Kits<br>2 @ 0.27-0.53"<br>2 @ 0.38-0.70" | Up to 8 with Dual Grommet Kits<br>4 @ 0.27-0.53"<br>4 @ 0.38-0.70" | Up to 12 with Dual Grommet Kits<br>6 @ 0.4-0.6"<br>6 @ 0.7-0.9" |
| CLOSURE TEST <sup>1,2</sup>                       |  |  |  |   |
| Cable Retention (100 lbs.)                        | Passed   | Passed   | Passed   | Passed  |
| Impact Resistance (0-40 °C)                       | Passed   | Passed   | Passed   | Passed  |
| Chemical Resistance                               | Passed   | Passed   | Passed   | Passed  |
| Cable Flexing                                     | Passed   | Passed   | Passed   | Passed  |
| Dust (Weather Tightness)                          | Passed   | Passed   | Passed   | Passed  |
| Driving Rain                                      | Passed   | Passed   | Passed   | Passed  |
| Rodent Test                                       | Passed   | Passed   | Passed   | Passed  |
| Dimensions<br>(L x W x D) in. (cm)                | 36.00 x 8.00 x 4.00<br>(91.44 x 20.32 x 10.16)                     | 36.00 x 8.00 x 4.00<br>(91.44 x 20.32 x 10.16)                     | 27.00 x 8.25 x 4.00<br>(68.58 x 20.96 x 10.16)                     | 27.00 x 11.25 x 7.50<br>(68.58 x 28.58 x 19.05)                 |
| Weight lbs. (kg)                                  | 8.5 (3.86)   | 8.5 (3.86)   | 6.4 (2.90)   | 18 (8.16)   |

Note 1: Tested to Telcordia GR-771-Core and Aerial Strand requirements

Note 2: Not all Telcordia tests are listed due to space constraints; All closures are designed and tested to appropriate aerial test requirements

## ADSS Strand Mounting

FA000108 is used to attach the weathertight closures to a formed wire dead end.



## LG-500

### Ordering Information

| DESCRIPTION  | MODEL NO.                     | AFL NO.      |
|--|-------------------------------|--------------|
| LG-500 Aerial Weathertight Fiber Optic Splice Closure—Stores 144 single fusion or 432 mass fusion, includes (4) cable kits for sealing/retention and (2) ground terminals with removable bond, and hanger brackets. Not included: Splice Trays or Cable Grounding Kits | LG-500-U-0                    | FC000026     |
| LL-2400 Single Splice Tray—Stores (24) single fusion splices. Maximum of 4 trays in the LG-500.  | LL-2400                       | 91710-06     |
| LL-2448 Universal Splice Tray—Stores (24) single fusion or (4) mass fusion splices (48 F), *Mechanical. Maximum of 3 trays in the LG-500.  | LL-2448                       | 911289-00-02 |
| LL-4848 Mass Splice Tray—Stores (12) mass fusion splices (144 F). Maximum of 3 trays in the LG-500.  | LL-4848                       | 911437-00-02 |
| LL-2448-48S Single Splice Tray—Stores (48) single fusion splices. Maximum of 3 trays in the LG-500.  | LL-2448-48S                   | FA000045     |
| Small Single Grommet Kit (10 pc grommet only)<br>(Min 0.38" - Max 0.82")   | Small Single Grommet Kit (10) | 911496-00-00 |
| Small Dual Grommet Kit—Includes: (2) small dual grommets and hardware (Min 0.27" - Max 0.53" and Min 0.38" - Max 0.70")  | Small Dual Grommet Kit        | 911386-00-01 |
| Small Dual Grommet Kit (10 pc grommet only)<br>(Min 0.27" - Max 0.53" and Min 0.38" - Max 0.70")   | Small Dual Grommet Kit (10)   | 911495-00-00 |



\* See [Aerial Accessories specification sheet](#).  
See [Splice Tray specification sheet](#).

## LG-500-FTTx

The LightGuard® (LG) 500 FTTx Aerial Weathertight Fiber Optic Splice Closure is designed for small count fiber splicing (up to 32 single or 48 mass) in a butt or in-line configuration. Utilized in aerial applications, the LG-500-FTTx is ideal for FTTx access networks by providing cable entry and connectivity for up to 12 drop cables and 16 connections, requiring only a common can wrench for installation.

### Ordering Information

| DESCRIPTION   | MODEL NO.                           | AFL NO.      |
|---|-------------------------------------|--------------|
| LG-500-FTTx Aerial Weathertight Fiber Optic Splice Closure—Stores 32 single fusion or 48 mass fusion, includes (4) cable kits for sealing/retention and (2) ground terminals with removable bond, (1) splice tray, and hanger brackets. Not included: Cable Grounding Kits, SC/APC Adapters | LG-500-FTTx                         | FC000899     |
| LL-2425 Single Splice Tray—Stores (32) single fusion splices. Maximum of 1 tray in the LG-500-FTTx.   | LL-2425                             | FC000053     |
| Small Single Grommet Kit of (10 pc grommet only) (Min 0.38" - Max 0.82")  | Small Single Grommet Kit (10)       | 911496-00-00 |
| Small Dual Grommet Kit—Includes: (2) small dual grommets and hardware (Min 0.27" - Max 0.53" and Min 0.38" - Max 0.70")   | Small Dual Grommet Kit              | 911386-00-01 |
| Small Dual Grommet Kit (10 pc grommet only) (Min 0.27" - Max 0.53" and Min 0.38" - Max 0.70")   | Small Dual Grommet Kit (10)         | 911495-00-00 |
| Small 6-Port Drop Cable Kit—2 grommets with tie wrap and foam tape. Allows six cable entries (Min 0.20" - Max 0.37" and flat drop)  | Small 6 Port Drop Kit               | FC000573     |
| Adjustable Aerial Hanger Kit Bracket Kit (included with closure)  | Adjustable Hanger<br>LG-400/500/600 | 911497-00-00 |
| Extended Offset Aerial Hanger Kit LG-400/500/600  | Offset Hanger LG-400/500/600        | 91990-00     |

## LG-600

### Ordering Information

| DESCRIPTION  | MODEL NO.                           | AFL NO.      |
|--|-------------------------------------|--------------|
| LG-600 Aerial Weathertight Fiber Optic Splice Closure—Stores 384 single fusion or 1152 mass fusion, includes (4) cable kits for sealing/retention and (2) ground terminals with removable bond and hanger brackets. Not included: Splice Trays or Cable Grounding Kits | LG-600-U-0                          | FC000029     |
| LL-2400 Single Splice Tray—Stores (24) single fusion splices. Maximum of 12 trays in the LG-600.   | LL-2400                             | 91710-06     |
| LL-2448 Universal Splice Tray—Stores (24) single fusion or (4) mass fusion splices (48 F). Maximum of 8 trays in the LG-600, *Mechanical   | LL-2448                             | 911289-00-02 |
| LL-4848 Mass Splice Tray—Stores (12) mass fusion splices (144 F). Maximum of 8 trays in the LG-600   | LL-4848                             | 911437-00-02 |
| LL-2448-48S Single Splice Tray—Stores (48) single fusion splices. Maximum of 8 trays in the LG-600   | LL-2448-48S                         | FA000045     |
| Large Single Grommet Kit with retention hardware (Min 0.44" - Max 1.00")   | Large Single Grommet Kit            | FC000623     |
| Large Single Grommet Kit (10 pc grommet only) (Min 0.44" - Max 1.00")  | Large Single Grommet Kit (10)       | 91918-00     |
| Large Dual Grommet Expansion Kit—Includes: (2) Dual grommets and hardware (Min 0.40" - Max 0.70" and Min 0.60" - Max 0.90")  | Large Dual Grommet Kit              | 911406-00-00 |
| Large 6 Port Drop Cable Kit—2 Grommets with retention bracket. Allows six cable entries (Min 0.23" - Max 0.48" and flat drop)  | Large 6 Port Drop Kit               | FC000352     |
| Adjustable Aerial Hanger Kit Bracket Kit (included with closure)   | Adjustable Hanger<br>LG-400/500/600 | 911497-00-00 |

[Back to Table of Contents](#)

## LG-600-FTTx

The LightGuard (LG) 600 FTTx/32 Aerial Weathertight Fiber Optic Splice Closure is designed for small count fiber splicing (up to 96 single or 288 mass) in a butt or in-line configuration. Utilized in aerial applications, the LG-600-FTTx/32 is ideal for accommodating up to 24 drop cables and 32 connections with AFL's slim LGX® 118 adapter plate by placing 16 simplex adapters at each end of the inner security enclosure. Additionally, the closure can house 1x4, 1x8, 1x16, or 1x32 PLC splitter combinations and requires only a common can wrench for installation.



## Ordering Information

| DESCRIPTION   | MODEL NO.                           | AFL NO.      |
|---|-------------------------------------|--------------|
| LG-600-FTTx/32 Aerial Weathertight Fiber Optic Splice Closure—Stores 96 single fusion or 288 mass fusion, includes (6) cable kits for sealing/retention and (2) ground terminals with removable bond, splice tray and hanger brackets. Not included: Cable Grounding Kits | LG-600-FTTx/32                      | FC000806     |
| LL-2450 Single Splice Tray—Stores (12) single fusion splices. Maximum of 2 trays in the LG-600-FTTx/32.   | LL-2450                             | 91957-00     |
| LL-4850 Mass Splice Tray—Stores (8) mass fusion splices (96 F). Maximum of 2 trays in the LG-600-FTTx/32.   | LL-4850                             | 91958-00     |
| LL-1248 Universal Splice Tray—Stores (12) single fusion splices or (8) mass fusion splices (96 F), *Mechanical. Maximum of 2 trays in the LG-600-FTTx/32.   | LL-1248                             | 91121-00-00  |
| Large Single Grommet Kit with retention hardware (Min 0.44" - Max 1.00")  | Large Single Grommet Kit            | FC000623     |
| Large Single Grommet Kit of (10 pc grommet only) (Min 0.44" - Max 1.00")  | Large Single Grommet Kit (10)       | 91918-00     |
| Large Dual Grommet Expansion Kit—Includes: (2) Dual grommets and hardware (Min 0.40" - Max 0.70" and Min 0.60" - Max 0.90")   | Large Dual Grommet Kit              | 911406-00-00 |
| Large 6 Port Drop Cable Kit 2 Grommets with retention bracket—Allows six cable entries (Min 0.23" - Max 0.48" and flat drop)  | Large 6 Port Drop Kit               | FC000352     |
| Adjustable Aerial Hanger Kit Bracket Kit (included with closure)  | Adjustable Hanger<br>LG-400/500/600 | 911497-00-00 |

\* [See Aerial Accessories specification sheet.](#)  
[See Splice Tray specification sheet.](#)

# SPLITTING

## Centralized Split

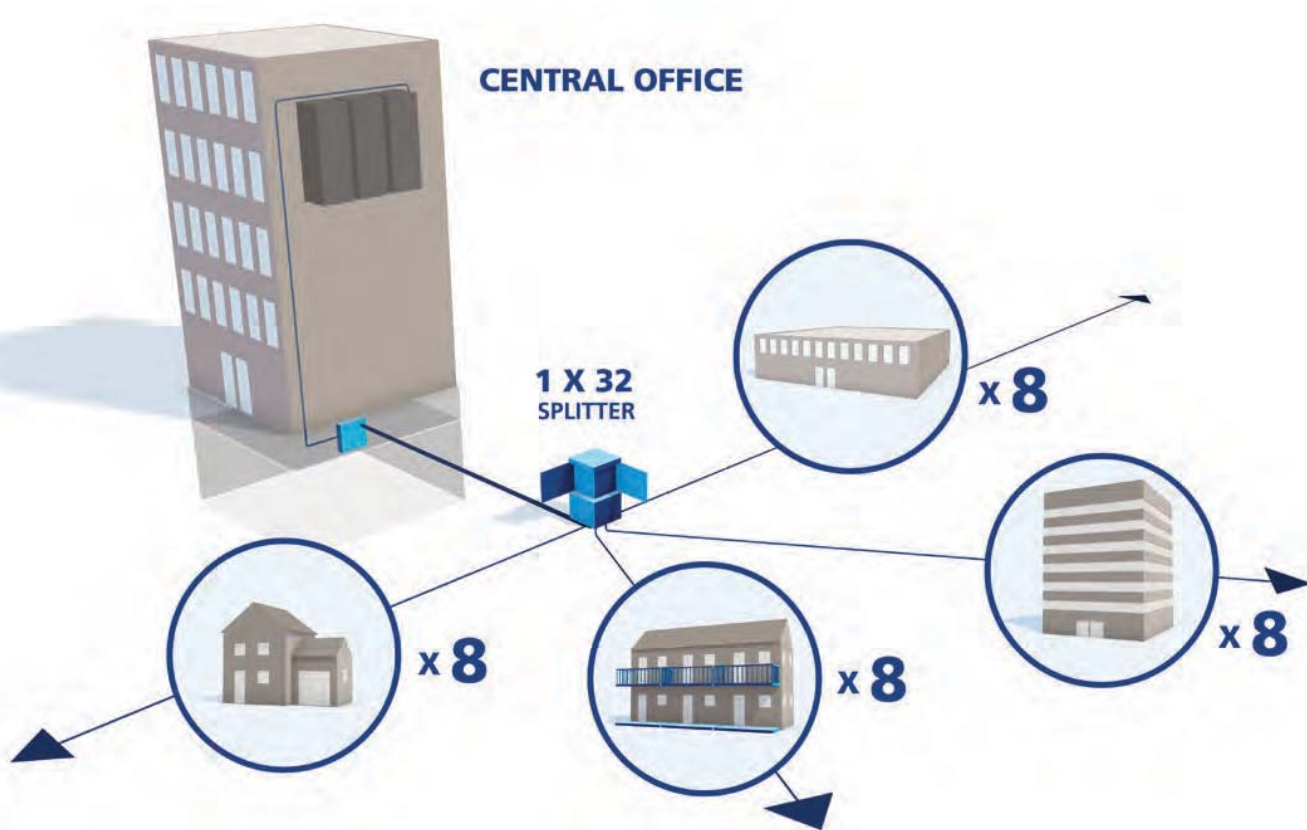

## Exterior Distribution Cabinets

### IDEAA® Cabinets

#### Specifications

| THROUGH PORTS   | HEIGHT | WIDTH | DEPTH | SPLITTER CAPACITY | INPUT/PASS        |
|-----------------|--------|-------|-------|-------------------|-------------------|
| Up to 288 Fiber | 38"    | 20"   | 20"   | 9                 | 24                |
| 432 Fiber       | 46"    | 20"   | 20"   | 14-15             | 24 (48 available) |
| 576 and 864     | 48"    | 42.5" | 20"   | 28                | 144               |

#### Ordering Information

| DESCRIPTION   | AFL NO.  |
|---|----------|
| <b>PAD MOUNT WITH SKIRT AND 100 FOOT TAILS</b>  |          |
| IDEAA Exterior Distribution Cabinet - 72 Pad, 1 x 72 Fiber Distribution Cable (Loose Tube), 1 x 24 Fiber Input Cable (Loose Tube)   | EA000307 |
| IDEAA Exterior Distribution Cabinet - 144 Pad, 1 x 144 Fiber Distribution Cable (Loose Tube), 1 x 24 Fiber Input Cable (Loose Tube)   | EA000304 |
| IDEAA Exterior Distribution Cabinet - 216 Pad, 1 x 216 Fiber Distribution Cable (Loose Tube), 1 x 24 Fiber Input Cable (Loose Tube)   | EA000305 |
| IDEAA Exterior Distribution Cabinet - 288 Pad, 1 x 288 Fiber Distribution Cable (Loose Tube), 1 x 24 Fiber Input Cable (Loose Tube)   | EA000301 |
| IDEAA Exterior Distribution Cabinet - 432 Pad, 2 x 216 Fiber Distribution Cable (Loose Tube), 1 x 24 Fiber Input Cable (Loose Tube)   | EA000321 |
| IDEAA Exterior Distribution Cabinet - 864 Pad, 2 x 432 Fiber Distribution Cable (Wrapping Tube Cable (WTC), with SpiderWeb Ribbon®), 1 x 144 Fiber Input Cable (Wrapping Tube Cable (WTC), with SpiderWeb Ribbon) | EA000590 |
| <b>PAD MOUNT WITH SKIRT AND 100 FOOT TAILS</b>  |          |
| IDEAA Exterior Distribution Cabinet - 144 Pole, 1 x 144 Fiber Distribution Cable (Loose Tube), 1 x 24 Fiber Input Cable (Loose Tube)  | EA000314 |
| IDEAA Exterior Distribution Cabinet - 288 Pole, 1 x 288 Fiber Distribution Cable (Loose Tube), 1 x 24 Fiber Input Cable (Loose Tube)  | EA000302 |
| IDEAA Exterior Distribution Cabinet - 432 Pole, 2 x 216 Fiber Distribution Cable (Loose Tube), 1 x 24 Fiber Input Cable (Loose Tube)  | EA000322 |



## IDEAA® Splitter Modules

### Specifications

| PARAMETER                   | VALUE       |      |      |      |      |
|-----------------------------|-------------|------|------|------|------|
|                             | 1X4         | 1X8  | 1X16 | 1X32 | 1X64 |
| Wavelength Range (nm)       | 1280 - 1650 |      |      |      |      |
| Typical Insertion Loss (dB) | 6.7         | 9.8  | 12.9 | 16.6 | 19.8 |
| Max Insertion Loss (dB)     | 7.4         | 10.5 | 14   | 17.5 | 21   |
| Max IL Uniformity (dB)      | 1           | 1    | 1.5  | 2    | 2.2  |
| Return Loss (dB)            | ≥55         |      |      |      |      |
| Directivity (dB)            | ≥55         |      |      |      |      |
| Max PDL (dB)                | 0.3         |      |      |      |      |

## IDEAA Exterior Distribution Enclosures

### Specifications

| PARAMETER                  | VALUE  |
|----------------------------|--|
| Material - Housing         | 16 Gauge Aluminum  |
| Dimensions (H x W x D) in. | 20.5 x 11.25 x 8.75  |
| Weight                     | 15 lbs.  |
| Coating                    | Electrostatically applied powder paint                         |
| Covers                     | Standard - molded-in snap finger and 3/8 in. hex head fastener |

### Ordering Information

| DESCRIPTION   | AFL NO.  |
|---|----------|
| Exterior Distribution Enclosure – Splice Version – Includes 96 distribution pigtails, 12 feeder pigtails and 5 LL-4808 splice trays                           | EA000378 |
| Exterior Distribution Enclosure – Stub Version – Includes 50 ft. 96-fiber loose tube distribution cable stub and 50 ft. 12-fiber loose tube feeder cable stub | EA000379 |
| Channell Pedestal Mounting Kit  | EA000384 |
| Emerson Pedestal Mounting Kit   | EA000385 |

### Ordering Information

| DESCRIPTION                                  | AFL NO.  |
|--|----------|
| IDEAA Module, SC, 1X32                       | EA000102 |
| IDEAA Module, SC OUTPUT, LC INPUT, DUAL 1x16 | EA000583 |
| IDEAA Module, SC, 1X16                       | EA000103 |
| IDEAA Module, SC, 1X8                        | EA000104 |
| IDEAA Module, SC, 1X4                        | EA000105 |
| IDEAA Module, LC, 2X32                       | EA000547 |
| IDEAA Module, MTP, 3X96                      | EA000101 |



IDEAA Splitter Module and Exterior Distribution Enclosure in Pedestal

## Distributed Split

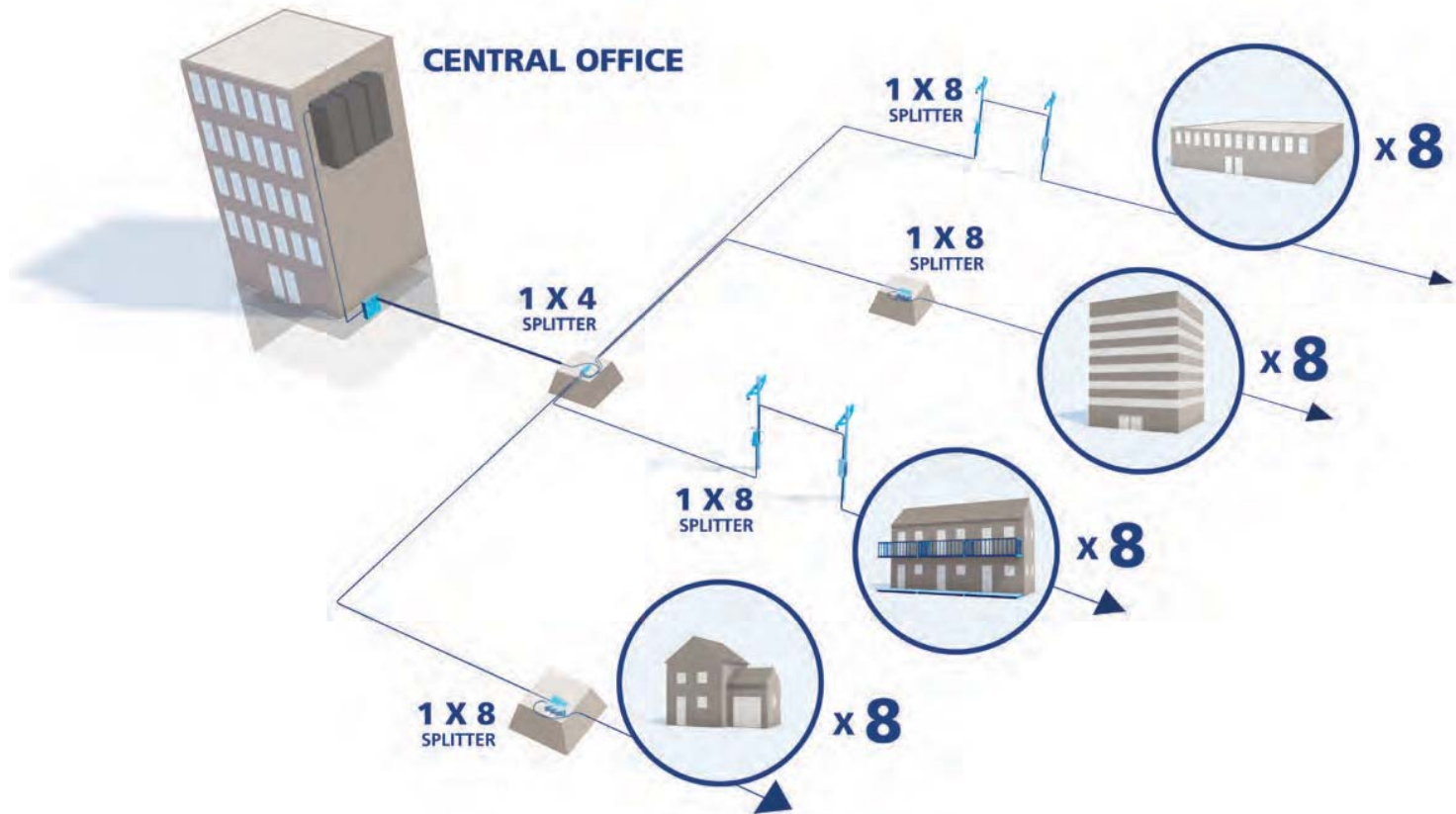



# NETWORK ACCESS POINT

## Multiport Terminals

### Specifications

| PARAMETER              | NO. OF PORTS   | VALUE  |
|------------------------|----------------|--|
| Dimensions (L x W x H) | 4- and 6-port  | 12.4" x 4.9" x 3.0"<br>(315 mm x 125 mm x 76 mm) |
|                        | 8- and 12-port | 15.5" x 6.1" x 3.8"<br>(394 mm x 195 mm x 96 mm) |
| Weight                 | 4- and 6-port  | 1.5 lb (0.7 kg)                                  |
|                        | 8- and 12-port | 2.5 lb (1.1 kg)                                  |



### Ordering Information

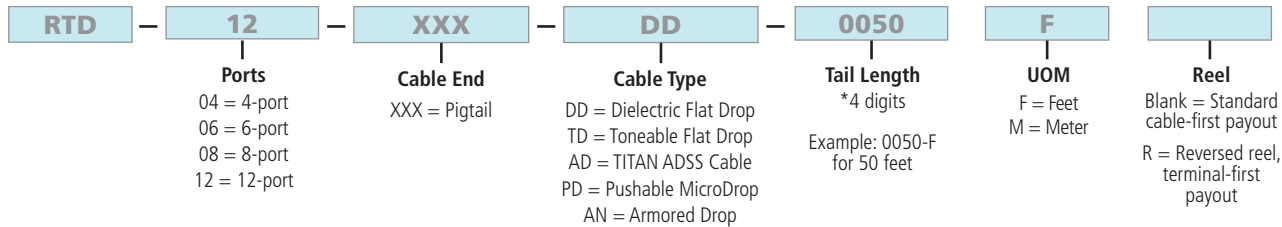

### Common Multiport Tail Length Distribution:

100 ft, 200 ft, 500 ft, 750 ft, 1000 ft, 1500 ft, 2000 ft, 2500 ft

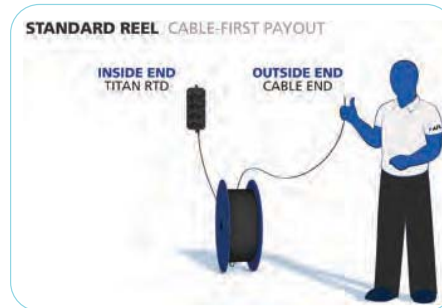

[Back to Table of Contents](#)

# Hardened Drops

## Cable Components

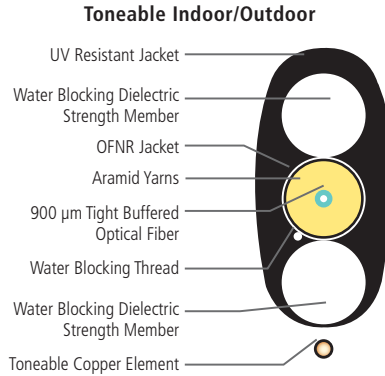
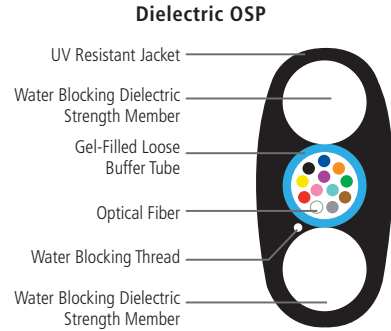

## Specifications

| PARAMETER                    | VALUE            |
|------------------------------|------------------|
| Insertion Loss, Maximum      | 0.50 dB          |
| Insertion Loss, Typical      | 0.15 dB          |
| Reflection                   | ≤ -65 dB         |
| Operating Temperature        | -40°C to +75°C   |
| Retention Force              | 25 lbs (111 N)   |
| Dust Cap Pulling Eye Tension | 100 lbs (444 N)* |

\*One fiber only. Two or four fiber drops should not be pulled by the dust cap pulling eye.

## Ordering Information

| TASC   | XXX  | TD   | 001                | Q  | 0100  | F                     |
|--|--|--|--------------------|--|---|-----------------------|
| <b>Outside End Connector</b>                           | <b>Inside End Connector</b>                            | <b>Cable Type</b>  | <b>Fiber Count</b> | <b>Fiber Type</b>  | <b>Cable Length</b>                         | <b>UOM</b>            |
| XXX = No connector<br>TASC = Trident<br>ASC = Angle SC | XXX = No connector<br>TASC = Trident<br>ASC = Angle SC | DD = Dielectric Flat Drop<br>TD = Toneable Flat Drop<br>KTD = Toneable Indoor/Outdoor Flat Drop<br>KDD = Dielectric Indoor/Outdoor Flat Drop<br>AN = Armored Drop<br>PD = Pushable MicroDrop | 001<br>002<br>004  | Q = Single-mode<br>ITU-T G.652.D<br><br>Z = Single-mode<br>ITU-T G.657.A2 BIF<br>(for I/O flat drop) | *4 digits<br>Example: 0100F<br>for 100 feet | F = Feet<br>M = Meter |

## Common Drop Length Distribution:

100 ft, 250 ft, 350 ft, 500 ft, 750 ft, 1000 ft, 1200 ft, 1500 ft

[Back to Table of Contents](#)

## PREMISE AND MULTI-DWELLING UNITS (MDU)

For FTTH deployments, fiber may be deployed to a single-family residence or some type of multi-dwelling unit. AFL offers a wide variety of demarcation boxes to meet these varying application requirements. Connectors and pre-terminated cables are often used here to connect fiber to the end-point.

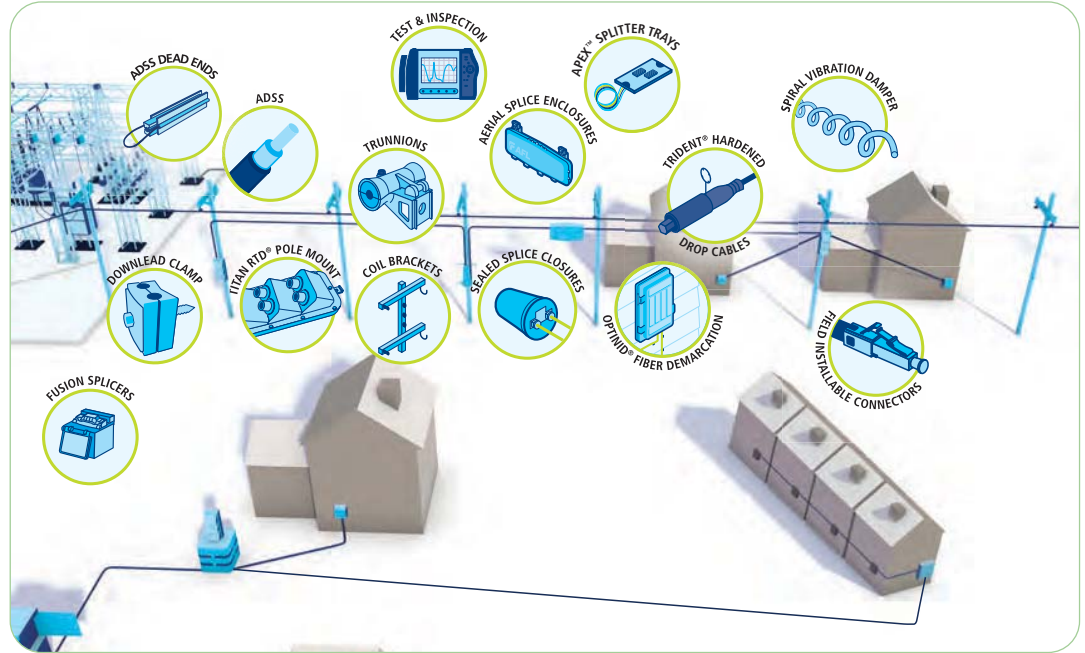

## Demarcation

### OptiNID® Duo Enclosure

Houses up to 4 SC connections.



### Ordering Information

|   |  |  |   |  |                         |  |   |   |   |   |                         |
|---|--|--|---|--|-------------------------|--|---|---|---|---|-------------------------|
| <b>O</b>  | <b>A</b>   | <b>A</b>   | <b>X</b>  | <b>A</b>   | <b>1</b>                | <b>X</b>   | <b>P</b>                                      | <b>S</b>                                  | <b>S</b>  | <b>P</b>  | <b>P</b>                |
| <b>OptiNID Duo</b>  | <b>Cover Logo</b>  | <b>Base</b>  | <b>Lockscrew</b>                                      | <b>Adapter</b>   | <b>Adapter Quantity</b> | <b>900 µm Pigtail Kit</b>  | <b>Grounding Plate</b>                        | <b>Splice Holder</b>                      | <b>Security/Splice Cover</b>  | <b>Left Entry Port</b>  | <b>Right Entry Port</b> |
| O = OptiNID Duo   | A = Standard AFL logo<br>Contact AFL for custom logo options | A = Base with two U-shaped drop-in grommets<br>B = Base with two holes for various entry options | X = No lockscrew (standard)<br>1 = 3/8" Hex lockscrew | X = No Adapter<br>A = SC/APC Simplex<br>B = SC/UPC Simplex<br>L = LC/UPC Duplex<br>N = LC/APC Duplex | 1-4                     | X = No Pigtail<br>A = SC/APC<br>B = SC/UPC<br>L = LC/UPC<br>N = LC/APC | X = No Grounding<br>P = 2-Lug Grounding Plate | X = No Splice Holder<br>S = Splice Holder | X = No Cover<br>S = Security/Splice Cover<br>K = Security/Splice Cover with pin-in-hex security screw | <p>A = Heyco compression fitting for 0.095" to 0.29" round cable<br/>B = Heyco compression fitting for 0.170" to 0.45" round cable<br/>D = PVC conduit fitting for 3/4" conduit<br/>G = Rubber grommet<br/>K = Heyco compression fitting for 0.26" to 0.545" round cable<br/>L = Heyco compression fitting for 2 round cables up to 0.15"<br/>M = Heyco compression fitting for flat drop cable<br/>N = PVC conduit fitting for 1/2" conduit<br/>U = U-shaped grommet for U-shaped grommet base</p> |                         |
| <p><b>NOTE:</b> Options A-N available with the two-hole entry option only</p> |  |  |   |  |                         |  |   |   |   |   |                         |

## Field-Installable Connectors

Choosing between a mechanical connector and a fusion spliced connector throughout the network can be a big decision. AFL has both capabilities; below is a summary comparison. Each project is different, and both are proven solutions for connectorization.

The FASTConnect® connector uses a mechanical splice and the FUSEConnect® connector uses a fusion splice.

### Comparison at-a-Glance

|                                 | FASTConnect             | FUSEConnect             |
|---------------------------------|-------------------------|-------------------------|
| Installation time               | Fastest                 | Fast                    |
| Optical performance             | Good                    | Best                    |
| Skill level                     | Novice                  | Moderate                |
| Re-enterable/re-usable          | Re-enterable            | No                      |
| Power required for installation | No                      | Yes                     |
| Costs                           | Least expensive         | Low cost                |
| Special tools required          | No                      | Requires fusion splicer |
| All tools required              | Fiber stripper          | Fiber stripper          |
|                                 | Kevlar scissors         | Kevlar scissors         |
|                                 | Fiber cleaning fluid    | Fiber cleaning fluid    |
|                                 | Lint-free wipes         | Lint-free wipes         |
|                                 | Permanent marker        | Permanent marker        |
|                                 | Precision fiber cleaver | Precision fiber cleaver |
|                                 |                         | Fusion splicer          |
|                                 | Cord splitter tool*     |                         |

\*Required only for certain connectors

|                     | FASTConnect                          | FUSEConnect  |
|---------------------|--------------------------------------|--|
| Optical performance | IL max: < 0.5 dB<br>RL max: ≥ 50 dB  | IL max: < 0.3 dB<br>RL max: ≥ 65 dB                  |
| Installation time   | 1-2 minutes                          | 2-3 minutes  |
| Skill level         | Novice                               | Moderate   |
| Tools required      | Common fiber tools and fiber cleaver | Common fiber tools, fiber cleaver and fusion splicer |

|                     | FASTConnect | FUSEConnect |
|---------------------|-------------|-------------|
| Optical performance |             | ✓           |
| Installation time   | ✓           |             |
| Skill level         | ✓           |             |
| Tool cost           | ✓           |             |
| Connector cost      | ✓           |             |
| Re-enterable        | ✓           |             |
| Reliability         |             | ✓           |

## FASTConnect® Mechanical Connectors

### Specifications

| PARAMETER                        | TYPE              | VALUE                            |
|----------------------------------|-------------------|----------------------------------|
| Insertion Loss:                  | Single-mode - UPC | Average: 0.2 dB, Maximum: 0.5 dB |
|                                  | Single-mode - APC | Average: 0.3 dB, Maximum: 0.6 dB |
|                                  | Multimode - PC    | Average: 0.1 dB, Maximum: 0.5 dB |
| Return Loss at Room Temperature: | Single-mode - UPC | Average: -50 dB, Maximum: -45 dB |
|                                  | Single-mode - APC | Average: -55 dB, Maximum: -50 dB |
|                                  | Multimode         | Average: -25 dB, Maximum: -20 dB |
| Operating Temperature            |                   | -40°C to +75°C                   |

### Ordering Information

| FIBER TYPE            | HOUSING COLOR | CABLE SIZE | AFL NO.          |                    |
|-----------------------|---------------|------------|------------------|--------------------|
|                       |               |            | PACKAGE OF 6     | PACKAGE OF 100     |
| <b>FASTCONNECT SC</b> |               |            |                  |                    |
| Single-mode, UPC      | Blue          | 900 µm     | FAST-SC-SM-6     | FAST-SC-SM-100     |
| Single-mode, APC      | Green         | 900 µm     | FAST-SC-SMAU-6   | FAST-SC-SMAU-100   |
| Single-mode, APC      | Green         | 4.8 mm     | FAST-SC48-SMAU-6 | FAST-SC48-SMAU-100 |
| <b>FASTCONNECT LC</b> |               |            |                  |                    |
| Single-mode, UPC      | Blue          | 900 µm     | FAST-LC-SM-6     | FAST-LC-SM-100     |

## FASTConnect® Universal Tool Kit

### Ordering Information

| DESCRIPTION   | AFL NO.     |
|---|-------------|
| FASTConnect High Precision Tool Kit with CT50 Cleaver | CS001201    |
| FASTConnect High Precision Tool Kit without cleaver   | CS001201-NC |
| FASTConnect High Precision Tool Kit with CT08 Cleaver | CS010975    |

#### Tool Kits include:

Cleaver, FAST SC Assembly Tool, FAST LC Assembly Tool, 3 mm Cable Clamp, 2 mm Cable Clamp, 0.25/0.9 mm Cable Clamp, Fiber Stripper, Kevlar Scissors, Fiber Preparation Fluid, Lint-free Cloth Wipes, Marker Pen, Installation Instructions, Strip Length Template and a Carrying Case.

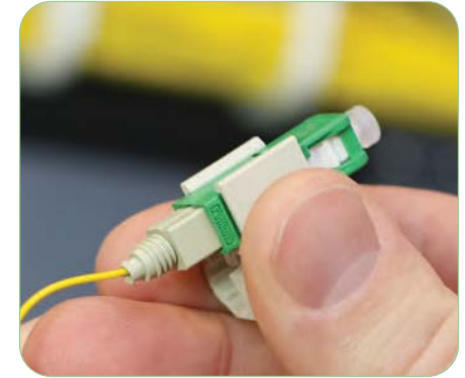

FASTConnect SC Connector



CT08 Cleaver

CT50 Cleaver

[Back to Table of Contents](#)

## FUSEConnect® Splice-on Connectors

### Specifications

| PARAMETER             | VALUE  |
|-----------------------|--|
| Connector Type        | SC, LC, FC, ST   |
| Cable Type            | 900 μm, 2 mm, 3 mm, 4.8 mm (SC only)   |
| Polish                | APC, UPC, PC   |
| Insertion Loss        | SM: 0.15 dB (average), 0.3 dB (maximum)<br>MM: 0.10 dB (average), 0.3 dB (maximum) |
| Return Loss           | SM: ≤ -65 dB (APC), ≤ -55 dB (UPC)<br>MM: ≤ -35 dB (PC)                            |
| Operating Temperature | -40°C to +75°C   |



Splicing a FUSEConnect ST Connector

### Ordering Information

| CONNECTOR TYPE | BOOT TYPE | AFL NO.*       |
|----------------|-----------|----------------|
|                |           | UPC SM (BLUE)  |
| SC             | 900 μm    | FUSE-SC9SMU-6  |
|                | 3 mm      | FUSE-SC3SMU-6  |
|                | 4.8 mm    | FUSE-SC48SMU-6 |
| LC             | 900 μm    | FUSE-LC9SMU-6  |
|                | 2 mm      | FUSE-LC2SMU-6  |

\* AFL NO. is for one pack of 6 pieces



FUSEConnect SC Kit

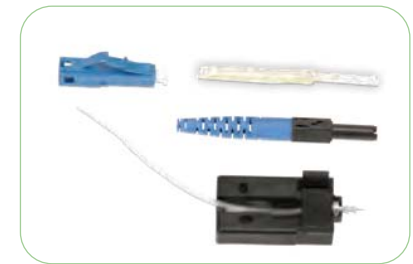

FUSEConnect LC Kit

## FUSEConnect® Universal Tool Kit

### Ordering Information

| DESCRIPTION  | AFL NO.           |
|--|-------------------|
| <b>FUSEConnect Tool Kit (includes items below)</b> | <b>FUSE-TL-KT</b> |
| Tool Case  | CS001202          |
| Fiber Stripper                                     | CS001205          |
| Kevlar Scissors                                    | C095257           |
| Lint-Free Wipes                                    | FM000413          |
| Fiber Preparation Fluid                            | FPF1-00-0900      |
| Permanent Marker                                   | C015830           |
| Cord Splitter Tool                                 | FUSE-ST-TL        |
| FUSEConnect Accessory Kit                          | FUSE-AC-KT        |

| FUSEConnect Accessory Kit (includes items below) | FUSE-AC-KT |
|--|------------|
| Utility Storage Box                              | CS012351   |
| Clamp for holding 3 mm Simplex Cordage           | S014704    |
| Clamp for holding 2 mm Simplex Cordage           | S014705    |
| 250 µm / 900 µm Fiber Clamp                      | CS004442   |
| 3 mm FUSEConnect Fiber Holder                    | S014695    |
| 2 mm FUSEConnect Fiber Holder                    | S014696    |
| 900 µm FUSEConnect Fiber Holder                  | S014697    |
| CLAMP-S70D Sheath Clamp                          | S015862    |
| CLAMP-S31S Sheath Clamp                          | S017101    |

| Cord Splitter Tool | FUSE-ST-TL |
|--------------------|------------|
|--------------------|------------|

| Legacy Splicer Accessories (Required for Fanout Splicing) |         |
|---|---------|
| CLAMP-S21B Sheath Clamp                                   | S016853 |
| CLAMP-S60D Sheath Clamp                                   | S014750 |



FUSEConnect Tool Kit Contents



FUSEConnect Accessory Kit



## Cable Assemblies

### Pigtail Assemblies

When splicing connectors at the demarcation box (NID) and more space is available to maintain a splice sleeve, a pigtail can be used.

### Drop Cable Assemblies



Ivory Single-ended



Black Double-ended

### Ordering Information

| POLISH   | FIBER TYPE | CONNECTOR INTERFACE AFL NO. |               |               |
|--|------------|-----------------------------|---------------|---------------|
|  |            | SC                          | ST            | LC            |
| <b>900 μm TIGHT-BUFFERED PIGTAIL KITS, 3 METER, 12-FIBER</b> |            |                             |               |               |
| APC  | SMF        | C223312-0003                | —             | CS002951-0003 |
| UPC  | SMF        | C223492-0003                | CS003979-0003 | CS001037-0003 |
| PC   | 62.5 μm    | CS000386-0003               | CS002150-0003 | CS002067-0003 |
| PC   | 50 μm      | CS001373-0003               | CS002136-0003 | CS002081-0003 |
| PC   | 50 μm LO   | CS003056-0003               | CS003980-0003 | CS003058-0003 |

### Specifications

| INSERTION LOSS |         | RETURN LOSS |        | FIBER TYPE                | MAX. ATTENUATION |           | NOMINAL DIAMETER  |                   | TENSION LBS (N)  |                 | BENDING RADIUS INCHES (MM) |                |
|----------------|---------|-------------|--------|---------------------------|------------------|-----------|-------------------|-------------------|------------------|-----------------|----------------------------|----------------|
| MAX.           | TYP.    | MAX.        | TYP.   |                           | 1310 NM          | 1550 NM   | INCHES (MM)       |                   | INSTALLATION     | LONG TERM       | INSTALLATION               | LONG TERM      |
| 0.25 dB        | 0.15 dB | -65 dB      | -68 dB | Bend Insensitive G.657.B3 | 0.5 dB/km        | 0.5 dB/km | 0.11 in. (3.0 mm) | 0.19 in. (4.8 mm) | 100 lbs. (450 N) | 30 lbs. (150 N) | 0.2 in. (5 mm)             | 0.2 in. (5 mm) |

### Ordering Information

|                                  |  |  |             |                                  |              |                             |                |
|----------------------------------|--|--|-------------|----------------------------------|--------------|-----------------------------|----------------|
| <b>ASC</b>                       |  | <b>KR</b>  | <b>001</b>  | <b>X</b>                         | <b>0010</b>  | <b>FT</b>                   | <b>BLACK</b>   |
| Connector End A                  | Connector End B  | Cable Type   | Fiber Count | Fiber Type                       | Cable Length | Unit of Measure             | Color          |
| ASC = Angle SC<br>USC = Ultra SC | ASC = Angle SC<br>USC = Ultra SC<br>Blank = Single Ended | K48R = Indoor/Outdoor 4.8 mm<br>KR = Indoor/Outdoor 3.0 mm | 001 = 1     | X = Bend Insensitive<br>G.657.B3 |              | Blank = Meters<br>FT = Feet | Ivory<br>Black |

[Back to Table of Contents](#)

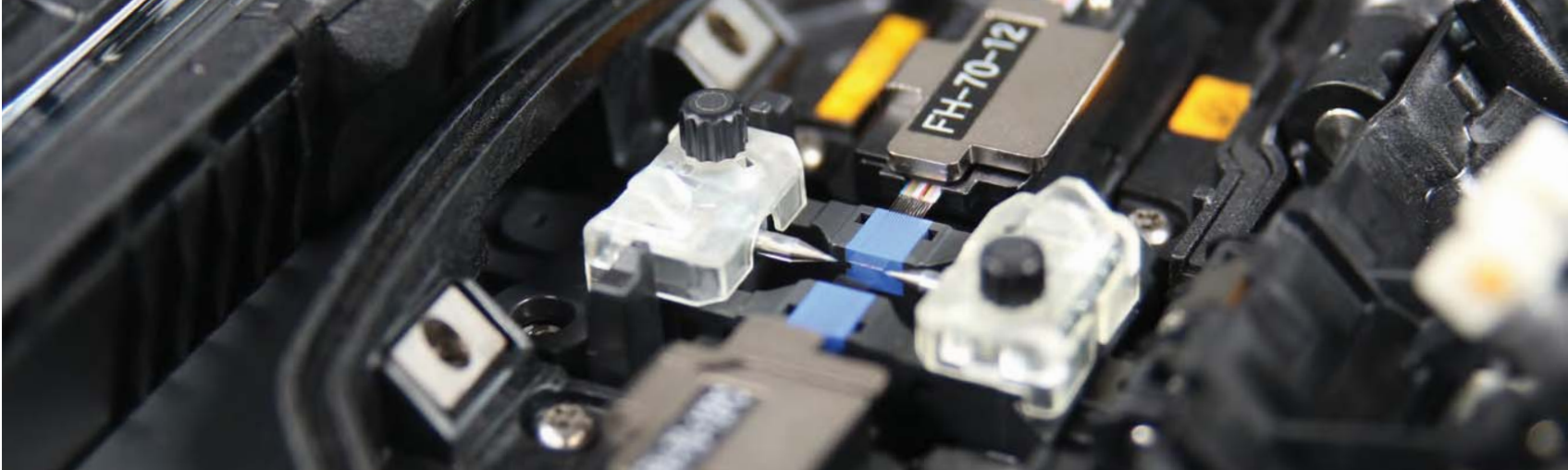

## FUSION SPLICERS

AFL proudly supplies and services the premier fusion splicing product line offered in North America through our parent company, Fujikura's fusion splicing solutions. Fujikura's pioneering spirit and keen focus on exceptional quality over the past three decades have established Fujikura as the leader in fusion splicing technology and product value.

AFL operates the only authorized repair facility for Fujikura splicing products in the U.S. AFL technicians are fully trained in repair and adjustment procedures in strict accordance with Fujikura specifications. When you choose a Fujikura splicing solution, AFL provides 24/7 technical support as well as complimentary on-site training with every splicer purchased.

# 90S Fusion Splicers

## Specifications

| PARAMETER                    |               | VALUE   |
|------------------------------|---------------|---|
| Fiber Alignment Method       |               | Active core alignment   |
| Fiber Count Can Be Spliced   |               | Single fiber  |
| Applicable Fiber             | Fiber Type    | Single mode optical fiber<br>Multi mode optical fiber   |
|                              | Cladding Dia. | 80 to 150 µm  |
| Applicable Coating           | Sheath Clamp  | Coating dia. : Max. 3,000 µm<br>Cleave length : 5 to 16 mm  |
| Fiber Splice Performance     | Splice Loss   | ITU-T G.652 : Avg. 0.02 dB  |
|                              |               | ITU-T G.651 : Avg. 0.01 dB  |
|                              |               | ITU-T G.653 : Avg. 0.04 dB  |
|                              |               | ITU-T G.654 : Avg. 0.04 dB  |
|                              |               | ITU-T G.655 : Avg. 0.04 dB  |
|                              |               | ITU-T G.657 : Avg. 0.02 dB  |
|                              | Splice Time   | SM FAST mode : Avg. 8 to 10 sec.<br>SM AUTO mode : Avg. 11 to 13 sec.<br>AUTO mode : Avg. 14 to 16 sec. |
| Applicable Protection Sleeve | Sleeve Type   | Heat-shrinkable sleeve  |
|                              | Sleeve Length | Max. 66 mm  |
|                              | Sleeve Dia.   | Max. 6.0 mm before shrinking  |
| Sleeve Heat Performance      | Heat Time     | 60 mm slim mode : Avg. 9 to 10 sec.<br>60 mm mode : Avg. 13 to 15 sec.                                  |
| Fiber Tensile Test Force     |               | Approx. 2.0 N   |
| Electrode Life               |               | Approx. 5,000 splices   |
| Physical Description         | Dimensions W  | Approx. 170 mm without projection   |
|                              | Dimensions D  | Approx. 173 mm without projection   |
|                              | Dimensions H  | Approx. 150 mm without projection   |
|                              | Weight        | Approx. 2.8 kg including battery  |
| Environmental Condition      | Temperature   | Operate : -10 to 50°C<br>Storage : -40 to 80°C  |
|                              | Humidity      | Operate : 0 to 95% RH non-condensing<br>Storage : 0 to 95% RH non-condensing                            |
|                              | Altitude      | Max. 5,000 m  |
| AC Adaptor                   | Input         | AC100 to 240 V, 50/60 Hz, Max. 1.5 A  |

| PARAMETER             |                                | VALUE                                     |               |
|-----------------------|--------------------------------|---|---------------|
| Battery Pack          | Type                           | Rechargeable Lithium Ion                  |               |
|                       | Output                         | Approx. DC14.4V / 6,380 mAh               |               |
|                       | Capacity                       | Approx. 300 splice and heat cycles        |               |
|                       | Temperature                    | Recharge                                  | : 0 to 30°C   |
|                       |                                | Storage                                   | : -20 to 30°C |
|                       | Battery Life                   | Approx. 500 recharge cycles               |               |
| Recharge Time         | Approx. 5 – 8 hours from empty |   |               |
| Display               | LCD Monitor                    | TFT 5 inches with touch screen            |               |
| Magnification         |                                | 200 to 320x                               |               |
|                       | Illumination                   | V-Grooves                                 | LED lamp      |
| Interface             | PC                             | USB2.0 Mini B type                        |               |
|                       | External Led Lamp              | USB2.0 A type, Approx. DC5V, 500 mA       |               |
|                       | Ribbon Stripper                | Mini DIN 6 pin, DC12V, Max. 1A            |               |
|                       | Wireless                       | Bluetooth 4.1 LE                          |               |
| Data Storage          | Splice Mode                    | 100 splice modes                          |               |
|                       | Heat Mode                      | 30 heat modes                             |               |
|                       | Splice Result                  | 20,000 splices                            |               |
|                       | Splice Image                   | 100 images                                |               |
| Screw Hole For Tripod |                                | 1/4-20 UNC                                |               |
| Other Features        | Automatic Functions            | Splice mode select by fiber type analysis |               |
|                       |                                | Discharge power calibration               |               |
|                       |                                | Wind protector: open/close                |               |
|                       |                                | Sheath clamp: open                        |               |
|                       |                                | Heater lid: open/close                    |               |
|                       | Heater clamp: open/close       |   |               |
|                       | Reference Guide                | Video and PDF file stored in splicer      |               |
|                       | Sheath Clamp                   | Easy sleeve positioning clamp             |               |
| Electrode             | Replaceable without tool       |   |               |

## 90S Fusion Splicers

### Ordering Information

| DESCRIPTION   | AFL NO. |
|---|---------|
| <b>90S Fusion Splicer (machine only) – includes:</b> ADC-20 AC Adapter, ACC-14 AC Cord, BTR-15 Battery, ELCT2-16B Spare Electrodes (pair), Sheath Clamps, SP-03 Fiber Holder Set Plates, USB-01 Cable, Alcohol Dispenser, Screwdriver, Splicer Carrying Strap, Quick Reference Guide, TS-03 Tripod Screw, Work Tray J-Plate, SS03 single fiber stripper and CC39 Transit Case with Carrying Strap                   | S017519 |
| <b>90S Fusion Splicer Kit (with cleaver) – includes:</b> CT50 Cleaver, ADC-20 AC Adapter, ACC-14 AC Cord, BTR-15 Battery, ELCT2-16B Spare Electrodes (pair), Sheath Clamps, SP-03 Fiber Holder Set Plates, USB-01 Cable, Alcohol Dispenser, Screwdriver, Splicer Carrying Strap, Quick Reference Guide, TS-03 Tripod Screw, Work Tray J-Plate, SS03 single fiber stripper and CC39 Transit Case with Carrying Strap | S017521 |
| <b>90S Fusion Splicer without Bluetooth (machine only) – includes:</b> ADC-20 AC Adapter, BTR-15 Battery, ACC-14 AC Cord, ELCT2-16B Spare Electrodes (pair), Sheath Clamps, SP-03 Fiber Holder Set Plates, USB-01 Cable, Alcohol Dispenser, Screwdriver, Splicer Carrying Strap, Quick Reference Guide, TS-03 Tripod Screw, Work Tray J-Plate, S03 Single Fiber Stripper and CC39 Transit Case with Carrying Strap  | S017520 |
| One Year Extended Warranty  | S012996 |
| Two Year Extended Warranty  | S013000 |

\* [See page 43](#) for Recommended Products for the 90S Fusion Splicer



In Work Tray

## 90R Fusion Splicers

### Specifications

| PARAMETER                    | VALUE  |  |
|------------------------------|--|--|
| Fiber Alignment Method       | Self cladding alignment with melting surface tension |  |
| Fiber Count Can Be Spliced   | Up to 16 fiber ribbon                                |  |
| Applicable Fiber             | Fiber Type   | Single-mode optical fiber  |
|                              | Cladding Dia.  | Multimode optical fiber<br>Approx. 125 μm  |
| Applicable Coating           | Sheath Clamp   | Coating shape. : Refer to options<br>Cleave length : 10mm  |
| Fiber Splice Performance     | Splice Loss  | ITU-T G.652 : Avg. 0.05 dB   |
|                              |  | ITU-T G.651 : Avg. 0.02 dB   |
|                              |  | ITU-T G.653 : Avg. 0.08 dB   |
|                              |  | ITU-T G.655 : Avg. 0.08 dB   |
|                              | Splice Time  | ITU-T G.657 : Avg. 0.05 dB<br>SM FAST mode : Avg. 14 to 15 sec.<br>SM AUTO mode : Avg. 19 to 20 sec. |
| Applicable Protection Sleeve | Sleeve Type  | Heat-shrinkable sleeve   |
|                              | Sleeve Length  | Max. 66 mm   |
|                              | Sleeve Dia.  | Max. 6.0 mm before shrinking   |
| Sleeve Heat Performance      | Heat Time  | 40 mm FP-05 mode : Avg. 38 to 40 sec.<br>40 mm FP-04T mode : Avg. 17 to 19 sec.                      |
| Fiber Tensile Test Force     |  | Single 60 mm mode: Avg. 13 to 15 sec.  |
| Electrode Life               |  | Approx. 2.0 N  |
| Physical Description         | Dimensions W   | Approx. 1,500 splices  |
|                              | Dimensions D   | Approx. 170 mm without projection  |
|                              | Dimensions H   | Approx. 173 mm without projection  |
|                              | Weight   | Approx. 150 mm without projection  |
| Environmental Condition      | Temperature  | Approx. 2.6 kg including battery<br>Operate : -10 to 50°C<br>Storage : -40 to 80°C                   |
|                              | Humidity   | Operate : 0 to 95% RH non-condensing   |
|                              | Altitude   | Storage : 0 to 95% RH non-condensing   |
| AC Adaptor                   | Input  | Max. 3,700 m<br>AC100 to 240 V, 50/60 Hz, Max. 1.5 A   |

| PARAMETER             | VALUE                                |   |
|-----------------------|--------------------------------------|---|
| Battery Pack          | Type                                 | Rechargeable Lithium Ion                      |
|                       | Output                               | Approx. DC14.4V / 6,380 mAh                   |
|                       | Capacity                             | Approx. 165 splice and heat cycles            |
|                       | Temperature                          | Recharge : 0 to 30°C<br>Storage : -20 to 30°C |
|                       | Battery Life                         | Approx. 500 recharge cycles                   |
| Display               | Recharge Time                        | Approx. 5 – 8 hours from empty                |
|                       | LCD Monitor                          | TFT 5 inches with touch screen                |
| Illumination          | Magnification                        | Approx. 20X : 12 Ribbon to 60X : Single       |
|                       | V-Grooves                            | LED lamp                                      |
| Interface             | PC                                   | USB 2.0 Mini B type                           |
|                       | External Led Lamp                    | USB 2.0 A type, Approx. DC5V, 500 mA          |
|                       | Ribbon Stripper                      | Mini DIN 6 pin, DC12V, Max. 1A                |
|                       | Wireless                             | Bluetooth 4.1 LE                              |
| Data Storage          | Splice Mode                          | 100 splice modes                              |
|                       | Heat Mode                            | 30 heat modes                                 |
|                       | Splice Result                        | 10,000 splices                                |
|                       | Splice Image                         | 100 images                                    |
| Screw Hole For Tripod |                                      | 1/4-20 UNC                                    |
| Other Features        | Automatic Functions                  | Splice mode select by fiber type analysis     |
|                       |                                      | Discharge power calibration                   |
|                       |                                      | Wind protector: open/close                    |
|                       |                                      | Sheath clamp: open                            |
|                       | Heater lid: open/close               |   |
|                       | Heater clamp: open/close             |   |
| Reference Guide       | Video and PDF file stored in splicer |   |
| Electrode             | Replaceable without tool             |   |

## 90R Fusion Splicers

### Ordering Information

| DESCRIPTION   | AFL NO. |
|---|---------|
| <b>90R Fusion Splicer (machine only) – includes:</b> BTR-15 Battery, ADC-20 AC Adapter, ACC-14 AC Cord, ELCT2-16B Spare Electrodes (pair) with spare V-Grooves (VG12-01), FH-70-12 Fiber Holder, USB Cable, Alcohol Dispenser, Splicer Carrying Strap, Quick Reference Guide, TS-03 Tripod Screw, Video Instruction Manual, Work Tray and CC-39 Transit Case with Carrying Strap  | S017509 |
| <b>90R Fusion Splicer Kit (with cleaver &amp; thermal stripper) – includes:</b> BTR-15 Battery, CT50 Cleaver, RS03 Stripper, ADC-20 AC Adapter, ACC-14 AC Cord, ELCT2-16B Spare Electrodes (pair) with spare V-Grooves (VG12-01), FH-70-12 Fiber Holder, USB Cable, Alcohol Dispenser, Splicer Carrying Strap, Quick Reference Guide, TS-03 Tripod Screw, Video Instruction Manual and CC-39 Transit Case with Carrying Strap                   | S017511 |
| <b>90R Fusion Splicer without Bluetooth (machine only) – includes:</b> BTR-15 Battery, ADC-20 AC Adapter, ACC-14 AC Cord, ELCT2-16B Spare Electrodes (pair) with spare V-Grooves (VG12-01), FH-70-12 Fiber Holder, USB Cable, Alcohol Dispenser, Splicer Carrying Strap, Quick Reference Guide, TS-03 Tripod Screw, Video Instruction Manual and CC-39 Transit Case with Carrying Strap   | S017540 |
| <b>90R Fusion Splicer Kit without Bluetooth (with cleaver &amp; thermal stripper) – includes:</b> BTR-15 Battery, CT50 Cleaver, RS01 Stripper, ADC-20 AC Adapter, ACC-14 AC Cord, ELCT2-16B Spare Electrodes (pair) with spare V-Grooves (VG12-01), FH-70-12 Fiber Holder, USB Cable, Alcohol Dispenser, Splicer Carrying Strap, Quick Reference Guide, TS-03 Tripod Screw, Video Instruction Manual and CC-39 Transit Case with Carrying Strap | S017510 |
| One Year Extended Warranty  | S012996 |
| Two Year Extended Warranty  | S013000 |

\* See page 43 for Recommended Products for the 90R Fusion Splicer



 Bluetooth®



Wind Protector Open

# 41S Fusion Splicers

## Specifications

| PARAMETER                       | VALUE   |
|---------------------------------|---|
| Model                           | 41S   |
| Applicable Fibers               | Single-mode (G.652 & G.657), Multimode (G.651), DSF (G.653), NZDS (G.655)   |
| Cladding Diameter               | 125 µm  |
| Coating Diameter                | 250 µm up to 3 mm   |
| Fiber Cleave Length             | 5 mm to 16 mm   |
| Typical Average Splice Loss     | 0.03 dB (SM), 0.01 dB (MM), 0.05 dB (DS) and 0.05 dB (NZDS)   |
| Splicing Time                   | Typical 6 sec with SM   |
| Arc Calibration Method          | Automatic, real-time and by using results of previous splice when in AUTO mode, manual arc calibration function available |
| Splicing Modes                  | Total 100 splice modes  |
| Splice Loss Estimate            | Determined with cladding or core alignment based on method selected by the user   |
| Storage of Splice Result        | 10,000 splice results   |
| Fiber Display                   | 5 inch TFT color LCD with X or Y view or both X and Y view simultaneously   |
| Magnification                   | 200X for single-camera view and 132X magnification for dual-camera view   |
| Viewing Method                  | 2 axis CMOS camera  |
| Operating Condition             | Altitude: 0 to 5,000 m above sea level, -10° to +50° C, Humidity: 0 to 95% RH, non-dew                                    |
| Mechanical Proof Test           | 1.96 N  |
| Tube Heater                     | 30 heating modes  |
| Tube Heating Time               | Typical 25 sec with FP-60 (60 mm) sleeve  |
| Protection Sleeve Length        | 60 mm, 40 mm, micro   |
| Splice/Heat Cycles with Battery | Typical 200 cycles with BTR-11A   |
| Electrode Life                  | 5,000 splices   |
| Power Supply                    | Auto select from 100 V to 240 V with AC adapter, 14.8 V DC with installed battery   |
| Terminals                       | USB 2.0   |
| Wind Protection                 | Maximum wind velocity of 15 m/s. (34 mph)   |
| Dimensions                      | 131 x 201 x 79 (mm)   |
| Weight                          | 1,300 g (2.85 lbs) with battery   |



## Ordering Information

| DESCRIPTION  | AFL NO. |
|--|---------|
| <b>Fujikura 41S Fusion Splicer – includes:</b> Fujikura 41S Fusion Splicer, S31A Sheath clamps (installed), FH-70-250 Fiber Holders (pair), FH-70-900 Fiber Holders (pair), SP-31 Set Plates, ADC-19A AC Adapter, BTR-11A Battery Pack (installed), ACC-09 Power Cord, ELCT2-16B Spare Electrodes (pair), Screwdriver, Operation Manual on CD, Quick Reference Guide, SS-03 Single Fiber Stripper and CC-36 Transit Case                                     | S017090 |
| <b>Fujikura 41S Fusion Splicer Kit with CT50 Cleaver – includes:</b> Fujikura 41S Fusion Splicer, CT50 Cleaver, S31A Sheath clamps (installed), FH-70-250 Fiber Holders (pair), FH-70-900 Fiber Holders (pair), SP-31 Set Plates, ADC-19A AC Adapter, BTR-11A Battery Pack (installed), ACC-09 Power Cord, ELCT2-16B Spare Electrodes (pair), Screwdriver, Operation Manual on CD, Quick Reference Guide, SS-03 Single Fiber Stripper and CC-36 Transit Case | S017091 |
| One Year Extended Warranty   | S012996 |
| Two Year Extended Warranty   | S013000 |

\* See page 43 for Recommended Products for the 41S Fusion Splicer

[Back to Table of Contents](#)

## Accessories for the 90S, 90R and 41S Fusion Splicers

| DESCRIPTION  | FOR USE WITH<br>SPLICER MODEL | AFL NO. |
|--|-------------------------------|---------|
| <b>Cleavers and Strippers</b>  |                               |         |
| CT08 Cleaver   | 90S, 41S                      | S017004 |
| CT50 Cleaver   | 90S, 90R, 41S                 | S017030 |
| RS01 Thermal Stripper  | 90R                           | S016815 |
| RS02 Thermal Stripper  | 90R                           | S016816 |
| RS03 Thermal Stripper  | 90R                           | S016817 |
| <b>Fiber Holders (pair)</b>  |                               |         |
| FH-70-250 (250 µm coated fiber)  | 90S, 90R, 41S                 | S017111 |
| FH-70-900 (900 µm jacketed fiber)                                      | 90S, 90R, 41S                 | S017113 |
| FH-60-LT900 (Loose buffer 900 µm fiber)                                | 90S, 90R, 41S                 | S015181 |
| FH-70-160 (160 µm coated fiber)  | 90S                           | S017095 |
| FH-70-2  | 90R                           | S017114 |
| FH-70-4  | 90R                           | S017115 |
| FH-70-6  | 90R                           | S017116 |
| FH-70-8  | 90R                           | S017117 |
| FH-70-10   | 90R                           | S017118 |
| FH-70-12   | 90R                           | S017119 |
| FH-70-12PC<br>(pitch conversion holder for 200 µm loose fibers)        | 90R                           | S017464 |
| FH-70-12-200 (200 µm pitch ribbons)                                    | 90R                           | S017681 |
| FH-70-16   | 90R                           | S017533 |
| <b>FUSEConnect® Accessories</b>  |                               |         |
| FH-FC-20 (900 µm within 2.0 mm sheathing) (each)                       | 90S, 90R, 41S                 | S014696 |
| FH-FC-30 (900 µm within 3.0 mm sheathing) (pair)                       | 90S, 90R, 41S                 | S014695 |
| FH-FC-900 (900 µm cable) (each)  | 90S, 90R, 41S                 | S014697 |
| CLAMP-FC-2000 (pair)   | 90S, 90R, 41S                 | S014705 |
| CLAMP-FC-3000 (pair)   | 90S, 41S                      | S014704 |
| <b>Power Supply Options and Equipment</b>                              |                               |         |
| BTR-11A Battery Pack   | 41S                           | S017354 |
| ADC-19A AC Adapter   | 41S                           | S017104 |
| ACC-09 Power Cord  | 41S                           | S014390 |
| ADC-20 AC Adapter  | 90S, 90R                      | S017513 |
| ACC-14 AC Power Cord   | 90S, 90R                      | S014536 |
| BTR-15 Battery   | 90S, 90R                      | S017512 |
| DCC-20 Power Cord<br>(connects AC Adapter to cigarette lighter socket) | 90S, 90R                      | S017527 |

| <b>Power Supply Options and Equipment (cont.)</b>                              |               |         |
|--|---------------|---------|
| DCC-21 Power Cord<br>(connects AC Adapter to power source via alligator clips) | 90S, 90R      | S017528 |
| DCA-03 DC Adapter (Connect AC Adaptor without battery)                         | 90S           | S017526 |
| <b>Miscellaneous</b>   |               |         |
| SS03 Single fiber stripper (3 hole)  | 90S, 90R, 41S | S017098 |
| SS01 Single fiber stripper (1 hole)  | 90S, 90R, 41S | S017099 |
| ELCT2-16B Electrodes   | 90S, 90R, 41S | S017103 |
| USB-01 Cable   | 90S, 41S      | S014777 |
| Splicer V-Groove Cleaning Kit  | 90S, 41S      | S014397 |
| SP-31 Set Plate (pair)   | 41S           | S017106 |
| CC-36 Transit Case   | 41S           | S017105 |
| CLAMP-S31A Sheath Clamps   | 41S           | S017100 |
| CLAMP-S31B Sheath Clamps for loose buffer 900 µm                               | 41S           | S017101 |
| CC-36 Transit Case   | 41S           | S017105 |
| SP-03 Fiber Holder Set Plates  | 90S           | S017518 |
| Portable Tripod Workstation (see <a href="#">specification sheet</a> )         | 90S, 90R      | S014773 |
| ASW-02 Splicing Workstation (see <a href="#">specification sheet</a> )         | 90S, 90R      | S010532 |
| WT-09R Work Tray Right   | 90S, 90R      | S017515 |
| WT-09L Work Tray Left  | 90S, 90R      | S017516 |
| JP-09 Work Tray J-Plate  | 90S, 90R      | S017517 |
| JP-10 J-Plate (Cooling tray attaches to splicer)                               | 90S, 90R      | S017522 |
| JP-10-FC J-Plate with Fiber Clamps   | 90S, 90R      | S017523 |
| TS-03 Tripod Screw (90 Series)   | 90S, 90R      | S017524 |
| ST-02 Fusion Splicer Strap   | 90S, 90R      | S017525 |
| CLAMP-DC-12 (Drop cable clamp for work tray)                                   | 90S, 90R      | S017550 |
| CC-39 Transit Case   | 90S, 90R      | S017514 |
| FST-12 Fiber Separation Tool   | 90R           | S014012 |
| FAT-04 Fiber Arrangement Tool  | 90R           | S010212 |
| RT-02 Fiber Arrangement Tool   | 90R           | S017465 |
| VG12-01 12 fiber V-groove  | 90R           | S017548 |
| VG12-01-200 12 fiber V-groove (200 µm pitch ribbons)                           | 90R           | S017680 |
| VG04-01 4 fiber V-groove   | 90R           | S017551 |
| VG08-01 Spare 8 fiber V-grooves  | 90R           | S017508 |
| VG16-01 16 fiber V-groove  | 90R           | S017552 |
| FAA-03A Ribbon Forming Adhesive (4 oz. bottle)                                 | 90R           | S008720 |
| FAA-03A Ribbon Forming Adhesive (0.5 liter bottle)                             |               | S008622 |



## NETWORK TEST AND INSPECTION

All fiber networks require optical testing and inspection for network verification and troubleshooting. AFL designs test and inspection tools that are easy to use and provide quick results, without complicated training requirements.

AFL has a complete range of fast, easy-to-use tools that inspect and clean fiber end-faces. Using these tools consistently eliminates the #1 cause of network outages – dirty connectors.

### FlexScan® FS200 Optical Time Domain Reflectometers (OTDRs)

FlexScan OTDRs are pocket-sized and performance packed. They enable both novice and expert technicians to quickly and reliably troubleshoot optical networks or fully characterize newly installed or repaired networks. FlexScan's SmartAuto® mode uses multi-pulse OTDR scans to quickly and accurately detect, locate, identify and measure network components and faults with just the push of a button. Results may be viewed as traditional OTDR traces or with LinkMap® color-coded icons which clearly identify detected events and their pass/fail status. FlexScan OTDRs weigh less than a pound and feature integrated OLS, OPM, VFL, Bluetooth® and PC-based TRM® 3.0 Test Results Manager reporting software.

Users can significantly reduce multi-fiber test times using FS200-300/304 Flexpress® fast tests plus FlexScan MPO switch control.



FlexScan FS200 SM OTDR

**Recommended FlexScan Configuration:**  
**FS200-304-BIPM-P1-W1-A-SC-ENG-US-ACS/ASC-ASC**



FlexScan FS200 PRO OTDR Kit

# FlexScan® FS200 Optical Time Domain Reflectometers (OTDRs)

## Ordering Information

FS200-[MOD]-[KIT]-[PW]-[C]-[LNG]-[AC]-[FR]-[TIP]<sup>a</sup> where:

| [MOD] | FS200 FLEXSCAN OTDR CONFIGURATION                                 |
|-------|---|
| 50    | 1550 nm only Troubleshooting OTDR                                 |
| 60    | 1650 nm filtered Live PON Troubleshooting OTDR                    |
| 100   | 1310/1550 nm Verification & Troubleshooting OTDR                  |
| 300   | 1310/1550 Pt-to-Pt & PON Verification & Troubleshooting OTDR      |
| 304   | 1310/1550/1650 Pt-to-Pt & PON Verification & Troubleshooting OTDR |

| [KIT] | FS200 FLEXSCAN KIT CONFIGURATION   |
|-------|--|
| BAS   | Basic kit with soft case, TRM 2.0 Basic, USB cable   |
| PLUS  | Adds 150 m Fiber Ring, One-Click cleaner, TRM 2.0 Advanced   |
| PRO   | Adds Fiber Ring, One-Click cleaner, TRM 2.0 Advanced, FOCIS Flex   |
| BIPM  | BIPM Complete kit adds OFI-BIPM to PRO kit   |
| MPO   | Multi-fiber kit includes FlexScan plus MPO Switch, MPO launch cable, OTDR-to-Switch patch cord, OTDR-to-Switch USB cable |

| [PW]   | POWER METER / WIRELESS OPTION   |
|--------|---|
| P0-W0  | No Source, Power Meter, or Bluetooth/WiFi (FS200-50/60/100 only)                      |
| P0-W1  | No Source or Power Meter; Includes Bluetooth/WiFi (FS200-300/304 only)                |
| P1-W0  | No Bluetooth/WiFi (-304 only); Includes Source, Power Meter                           |
| P1-W1  | Includes Source, Power Meter, Bluetooth/WiFi (all models except -50)                  |
| P1-W1H | Includes Source, Power Meter, Bluetooth/WiFi, hard carry case (all models except -50) |

| [C] | OTDR / SOURCE CONNECTOR TYPE |
|-----|------------------------------|
| A   | APC (recommended)            |
| U   | UPC                          |

| [LNG] | LANGUAGE      | DNK | Danish   | NOR | Norwegian  |
|-------|---------------|-----|----------|-----|------------|
| ENG   | English       | FIN | Finnish  | POL | Polish     |
| CHS   | Chinese Simp. | FRA | French   | POR | Portuguese |
| CHT   | Chinese Trad. | ITA | Italian  | SPA | Spanish    |
| CZE   | Czech         | JPN | Japanese | TUR | Turkish    |
| DEU   | German        | KOR | Korean   |     |            |

| [AC] | DESTINATION COUNTRY | AC PLUGS   |
|------|---------------------|------------|
| US   | USA                 | 2-pin, US  |
| EU   | European Union      | 2-pin, EU  |
| UK   | United Kingdom      | 2-pin, UK  |
| CN   | China, Australia    | 2-pin, SAA |

| [FR]   | 150 M SMF FIBER RING | [FR]       | 150 M SMF FIBER RING  |
|--------|----------------------|------------|-----------------------|
| Blank  | N/A in Basic kits    | ASC/ST     | FR1-SM-150-ASC-ST     |
| SC/SC  | FR1-SM-150-SC-SC     | ASC/ASC    | FR1-SM-150-ASC-ASC    |
| SC/FC  | FR1-SM-150-SC-FC     | ASC/AFC    | FR1-SM-150-ASC-AFC    |
| SC/LC  | FR1-SM-150-SC-LC     | ASC/ALC    | FR1-SM-150-ASC-ALC    |
| SC/ST  | FR1-SM-150-SC-ST     | ALC/ALC    | FR1-SM-150-ALC-ALC    |
| SC/ASC | FR1-SM-150-SC-ASC    | FC/FC      | FR1-SM-150-FC-FC      |
| SC/AFC | FR1-SM-150-SC-AFC    | FC/ST      | FR1-SM-150-FC-ST      |
| SC/ALC | FR1-SM-150-SC-ALC    | FC/LC      | FR1-SM-150-FC-LC      |
| LC/LC  | FR1-SM-150-LC-LC     | FC/AFC     | FR1-SM-150-FC-AFC     |
| LC/ASC | FR1-SM-150-LC-ASC    | AFC/AFC    | FR1-SM-150-AFC-AFC    |
| LC/ALC | FR1-SM-150-LC-ALC    | ASC-AE2000 | FR1-SM-150-ASC-AE2000 |
| ASC/FC | FR1-SM-150-ASC-FC    | SC-E2000   | FR1-SM-150-SC-E2000   |

| [TIP] * | FOCIS FLEX TIPS & CLEANING (PRO ONLY)                          |
|---------|--|
| Blank   | Option not available in Basic & PLUS kits                      |
| SC      | SC-UPC bulkhead tip, 2.5 mm UPC ferrule tip, 2.5 mm cleaning   |
| FC      | FC-UPC bulkhead tip, 2.5 mm UPC ferrule tip, 2.5 mm cleaning   |
| LC      | LC-UPC bulkhead tip, 1.25 mm UPC ferrule tip, 1.25 mm cleaning |
| ASC     | SC-APC bulkhead tip, 2.5 mm APC ferrule tip, 2.5 mm cleaning   |
| AFC     | FC-APC bulkhead tip, 2.5 mm APC ferrule tip, 2.5 mm cleaning   |
| ALC     | LC-APC bulkhead tip, 1.25 mm APC ferrule tip, 1.25 mm cleaning |

\* For additional FOCIS Flex adapter tips, see [FOCIS Flex spec sheet](#).

## FOCIS Flex

End-face inspection scope

### Ordering Information

| DESCRIPTION   | AFL NO.        |
|---|----------------|
| FOCIS Flex Kit, soft carry case / holster, USB cable, AC charger, TRM 2.0 reporting software, reference guide, no tips  | FOCIS-FLX-P4XN |
| FOCIS Flex Kit, soft carry case / holster, USB cable, AC charger, TRM 2.0 reporting software, reference guide, 2 user-selected UPC adapter tips (ferrule and bulkhead), user-selected One-Click cleaner | FOCIS-FLX-P4XU |
| FOCIS Flex Kit, soft carry case / holster, USB cable, AC charger, TRM 2.0 reporting software, reference guide, 2 user-selected APC adapter tips (ferrule and bulkhead), user-selected One-Click cleaner | FOCIS-FLX-P4XA |



### FOCIS Flex Adapter Tips

| DESCRIPTION                                | AFL NO.      |
|--|--------------|
| SC-UPC bulkhead adapter tip                | FFLX-01-SC   |
| FC-UPC bulkhead adapter tip                | FFLX-01-FC   |
| ST-UPC bulkhead adapter tip                | FFLX-01-ST   |
| LC-UPC bulkhead adapter tip                | FFLX-01-LC   |
| Universal 2.5 mm, UPC ferrule adapter tip  | FFLX-01-U25  |
| Universal 1.25 mm, UPC ferrule adapter tip | FFLX-01-U125 |
| SC-APC bulkhead adapter tip                | FFLX-4S-ASC  |
| FC-APC bulkhead adapter tip                | FFLX-4S-AFC  |
| LC-APC bulkhead adapter tip                | FFLX-4S-ALC  |
| Universal 2.5 mm, APC ferrule adapter tip  | FFLX-01-A25  |
| Universal 1.25 mm, APC ferrule adapter tip | FFLX-01-A125 |



SC/UPC bulkhead



LC/UPC bulkhead



Universal 2.5 mm,  
UPC ferrule



Universal 1.25 mm,  
APC ferrule



SC/APC bulkhead,  
quad-slotted



LC/APC bulkhead,  
quad-slotted, with internal prism

## Optical Fiber Identifiers

### Ordering Information

| DESCRIPTION  | AFL NO.    |
|--|------------|
| BI Optical Fiber Identifier with integrated Optical Power Meter. The kit includes one 2.5 mm Universal Power Meter Port Adapter, BIPM-00-25. | OFI-BIPM   |
| <b>OPTIONAL OFI-BIPM ADAPTERS (ORDERED SEPARATELY)</b>   |            |
| OFI-BIPM 2.5 mm Universal Power Meter Port Adapter   | BIPM-00-25 |
| OFI-BIPM SC Power Meter Port Adapter   | BIPM-00-SC |
| OFI-BIPM FC Power Meter Port Adapter   | BIPM-00-FC |
| OFI-BIPM ST Power Meter Port Adapter   | BIPM-00-ST |
| OFI-BIPM LC Power Meter Port Adapter   | BIPM-00-LC |



## Optical Power Meters

### Ordering Information

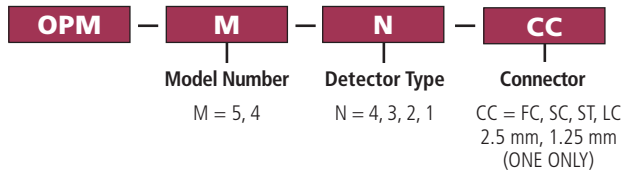

| MODEL   | CALIBRATED WAVELENGTHS (NM) |     |     |     |     |      |      |      |      |      | DETECTOR TYPE | MEASUREMENT RANGE (DBM) | PC SOFTWARE |         |
|---------|-----------------------------|-----|-----|-----|-----|------|------|------|------|------|---------------|-------------------------|-------------|---------|
|         | 650                         | 660 | 780 | 850 | 980 | 1300 | 1310 | 1490 | 1550 | 1625 |               |                         |             |         |
| OPM5-4D |                             |     |     | ◆   | ◆   |      |      | ◆    | ◆    | ◆    | ◆             | InGaAs                  | +26 to -50  | TRM 2.0 |
| OPM5-3D |                             |     |     | ◆   |     |      | ◆    | ◆    | ◆    | ◆    |               | InGaAs                  | +10 to -75  | TRM 2.0 |
| OPM5-2D |                             |     |     | ◆   |     |      | ◆    | ◆    | ◆    |      |               | Germanium               | +6 to -60   | TRM 2.0 |
| OPM4-4D |                             |     |     | ◆   | ◆   |      |      | ◆    | ◆    | ◆    | ◆             | InGaAs                  | +26 to -50  |         |
| OPM4-3D |                             |     |     | ◆   |     |      | ◆    | ◆    | ◆    | ◆    |               | InGaAs                  | +10 to -75  |         |
| OPM4-2D |                             |     |     | ◆   |     |      | ◆    | ◆    | ◆    |      |               | Germanium               | +6 to -60   |         |
| OPM4-1D | ◆                           | ◆   | ◆   | ◆   |     |      |      |      |      |      |               | Silicon                 | +6 to -70   |         |



[Back to Table of Contents](#)

## Test Results Manager TRM® 2.0/3.0 Software

### TRM 2.0/3.0 Basic Software Features

- Generate professional acceptance reports including:
  - OTDR traces
  - Certification loss results/OPM loss results
  - Connector end-face images from FOCIS Flex, FOCIS WiFi PRO and DFS1
  - Connector pass/fail results from FOCIS Flex
- Create certification results and apply Pass/Fail criteria
- Organize test results and document networks to reduce maintenance cost
- Powerful OTDR Batch editing to increase productivity
- Supports Telcordia (GR-196 v1.1, SR-4731 issue 1 & 2) .SOR file formats
- Languages Supported
  - English, Chinese, French, German, Italian, Japanese, Polish, Portuguese, Russian, Spanish & Turkish

### Ordering Information

TRM 2.0 Basic software is included with M-Series, C-Series, OFL-Series, FlexTester and FlexScan OTDRs and OPM5 (may be installed in up to 5 PCs). Users may download a full working version of TRM 2.0 (Basic plus Advanced features) and try it for 30 days. Once the evaluation period ends, users must purchase and install a TRM 2.0 Basic or Advanced software license to continue to use TRM. To order the TRM 2.0 software, contact your AFL Sales representative or AFL Customer Support. The TRM 2.0 Basic and Advanced software part numbers are listed below.

| DESCRIPTION   | AFL NO.       |
|---|---------------|
| TRM 2.0 Basic Software (OTDR Trace/OLTS Viewer, Batch Editor and Reports) | TRM-00-0900PR |
| TRM 2.0 Advanced Software (Basic TRM plus Advanced Features and Reports)  | TRM-00-0910PR |
| TRM 2.0 Upgrade from Basic to Advanced Software                           | TRM-00-0920PR |

### TRM 2.0/3.0 Advanced Software Features

- Macro/Microbend detection capabilities
  - Identify excess insertion loss due to poor installation and fiber handling
  - Detect insertion loss difference between wavelengths ( $\geq 0.2$  dB)
- Bi-directional trace analysis
  - Averages end-to-end and event loss measurements using results from both directions
  - Bi-directional trace information in the Event table
  - Reverse direction test data for each event
- Comprehensive Reports for Macrobend/Microbend and Bi-directional Trace Analysis
- Export .SOR file contents to .CSV format



[Back to Table of Contents](#)



## Don't Scrub Your Data

The connectors entrusted to carry the critical information that passes through your network deserve far more than a wipe on a t-shirt. Don't risk losing the critical information that passes through your network every day by inspecting and cleaning fiber incorrectly. A one micron diameter speck of dust obscures 1% of a 10 micron fiber core, resulting in about 0.06 dB of additional optical return loss. AFL's industry-leading cleaning and inspection solutions enable optimal data center performance levels and minimal service disruptions.

Visit our [Resource Hub](#) to read the "[New Does Not Equal Clean](#)" blog for more reasons why cleaning is important to keep your networks running in optimal condition.

**85%** OF ALL NETWORK FAILURES ARE DUE TO **DIRTY CONNECTORS**



[Back to Table of Contents](#)

# Cleaning

## One-Click® Cleaners

### Ordering Information

| DESCRIPTION  | AFL NO.        |
|--|----------------|
| One-Click Cleaner SC, ST, FC (500+ cleans)                               | 8500-05-0001MZ |
| One-Click Cleaner MU/LC (500+ cleans)                                    | 8500-05-0002MZ |
| One-Click Cleaner ODC, outdoor connector (500+ cleans)                   | 8500-05-0004MZ |
| One-Click Cleaner Mini-100 SC, ST, FC (100+ cleans)                      | 8500-05-0005MZ |
| One-Click Cleaner Mini-100 MU/LC (100+ cleans)                           | 8500-05-0006MZ |
| One-Click Cleaner Mini-500 SC, ST, FC (500+ cleans)                      | 8500-05-0009MZ |
| One-Click Cleaner Mini-500 MU/LC (500+ cleans)                           | 8500-05-0010MZ |
| One-Click Ultra Cleaner 2.5 (enlarged cleaning) SC, ST, FC (500+ cleans) | 8500-05-0007MZ |
| One-Click Cleaner D-LC, Duplex LC (2 x 500+ cleans)                      | 8500-05-0008MZ |
| One-Click Cleaner MPO (500+ cleans)                                      | 8500-05-0030MZ |
| One-Click Cleaner MPO-16 (500+ cleans)                                   | 8500-05-0013MZ |
| One-Click Cleaner MT-RJ (500+ cleans)                                    | 8500-05-0031MZ |



Mini-100 SC, ST, FC



Mini-100 MU/LC



Mini-500 SC, ST, FC



Mini-500 MU/LC



MU/LC



SC/ST/FC



D-LC



Ultra 2.5



MPO

# FCP3 Easy-Access Cleaning Kits

## Ordering Information

| DESCRIPTION   | AFL NO.      |
|---|--------------|
| <p><b>Basic Easy-Access Cleaning Kit.</b><br/> <b>Includes:</b> FCC2 Fiber Connector Cleaner and Preparation Fluid (can), FCC3 Debris Destroyer Fiber Optic Cleaning Pen, CCTS-12 (for 1.25 mm ferrule) and CCTS-25 (for 2.5 mm ferrule) Connector Cleaning Tips, Cletop-S Type B with White Tape, One-Click Cleaners (SC, LC/MU, Ultra 2.5, MPO/MTP), Soft Carry Case</p>            | FCP3-00-0900 |
| <p><b>Enterprise Easy-Access Cleaning Kit</b><br/> <b>Includes:</b> FCC2 Fiber Connector Cleaner and Preparation Fluid (can), FCC3 Debris Destroyer Fiber Optic Cleaning Pen, CCTS-12 (for 1.25 mm ferrule) and CCTS-25 (for 2.5 mm ferrule) Connector Cleaning Tips, Cletop-S Type B with White Tape, One-Click Cleaners (Duplex LC, LC/MU, Ultra 2.5, MPO/MTP), Soft Carry Case</p> | FCP3-00-0901 |



FCP3-00-0900



# AFL



[www.AFLglobal.com](http://www.AFLglobal.com)

# Appendix D

Alpha Power Supply Cabinet

# Power

## FlexNet™ FMPS

Multipurpose Power Supply



- Fiber-to-the-Premise UPS for Multiple Dwelling, Multiple Tenant and Small Business Unit applications
- Supports one or two MDU/SBU ONTs located up to 100ft from FMPS
- Battery management performs periodic battery capacity testing and status reporting to the ONT and customer
- Battery heater option provides extended runtime for applications in cold winter conditions
- Hybrid 16AWG and alarm cable minimizes installation labor
- Status indicators and audible alarm provide local status

Alpha extends its family of FlexNet FTTx powering solutions to include the FTTx Multipurpose Power Supply (FMPS) supporting MDU, MTU and SBU ONT products. The FMPS is an intelligent microprocessor controlled 48Vdc UPS system. The input is powered from either a customer owned 90 to 320Vac power outlet or a hard-wired AC connection. System includes one or two parallel outputs and alarm connections, supporting distances of up to 100ft between the FMPS and ONT, allowing the FMPS to be located close to existing power outlets. Individually monitored 48Vdc strings of standard 7.2Ah maintenance free, sealed lead acid batteries provide standby power. Battery heater models support extended runtimes at -40°C. LED indicators and an audible alarm provide local visual status, and PacketCable compliant telemetry connections to the ONT provide remote status reporting.

# FlexNet FMPS

## Specifications

### Input

AC Input Voltage: 90 to 320Vac  
 AC Input Frequency: 45 to 66Hz  
 Surge protection: ANSI/IEEE Std. C62.41 to Category A, B, or C requirements, using a "Ring Wave" or "Combination" waveform, at a level of 6kV

### Output

Operational Output Power: 150W continuous  
 170W, 10sec max.  
 Output Voltage: 48 to 58Vdc w/AC power, 42 to 58Vdc with battery  
 Output Current: 3.1A typical (crowbar limited beyond 5A DC)  
 Output Power Loading: Following GR-909 telephone lines in various states, e.g., ringing, off-hook, on-hook, data, and video operation requirements.  
 Ripple: Less than 3mVrms  
 Noise: Less than 100mVp-p  
 Output Connection: Two terminal blocks accepting 16AWG, parallel connections

### Local Alarms

System LED:  Green Steady = System Output Normal, DC Output  
 Off = No AC or Battery Power  
 Battery LED:  Yellow Steady = System on Battery  
 Off = Normal Mode  
 Replace Battery:  Red Steady = Replace One or Two Battery Strings  
 Off = Batteries Within Parameters  
 Replace Battery A&B (Internal): Steady Red = Replace One or Both Battery Strings  
 Off = Batteries Within Parameters

### Remote Alarms

Connection: Two five position IDC 24AWG, parallel connections  
 Pin 1 Alarm Return: Open collector return reference  
 Pin 2 AC Fail: On battery  
 Pin 3 Replace Battery: One or both battery strings failed periodic self test  
 Pin 4 Missing Battery: Less than eight batteries  
 Pin 5 Battery Low: Battery string voltage is less than 46.8Vdc

### Local - Audible Indicator

Alarm On: "Alarm Enable/Disable" toggle switch located on UPS  
 Batteries Below Voltage Parameters

### Physical

FMPS  
 Dimensions (in): 14W x 23.75H x 5.5D  
 (cm): 35.6W x 60.3H x 14D  
 Weight (lb/kg): 25/11.3  
 FMPS + Shipping Carton  
 Dimensions (in): 17W x 28.5H x 11.75D  
 (cm): 35.6W x 60.3H x 14D  
 Weight (lb/kg): 30/13.6

### Battery

Battery Type: Four or eight 7.2Ah Valve Regulated Lead Acid (VRLA) (Batteries sold separately)

### Environment

Operating (with heater option): -40 to 46°C (-40 to 115°F) plus solar loading, 0 to 95%  
 (without heater option): -10 to 46°C (14 to 115°F) plus solar loading, 0 to 95% humidity, 0 to 10000ft (0 to 3000m) elevation  
 Storage: -15 to 85°C (-5 to 185°F), 0 to 95% humidity, 0 to 50000ft (0 to 15000m) elevation

### Compliance

CSA/UL 60950, EN 60950, EN 55022 Class B, FCC Part 15 Class B, GR-63 Sect 4.2 Fire Resistance, GR-1089 Sect 3 Emissions, Sect 4 Lightning and AC Power Fault, Sect 7 Electrical Safety, CE, C-Tick, RoHS 5

### Warranty

3 year repair or replace

### Part Numbers

010-592-20-050 FlexNet FMPS, 120V Line cord, 150W, 48Vdc out, -40°C, Verizon  
 010-592-20-052 FlexNet FMPS, FTTX Multipurpose PS, 120V line cord, 150W  
 010-592-20-053 FlexNet FMPS, FTTX Multipurpose PS, 120V line cord, -40°C



FMPS with cover removed and two 7.2Ah battery strings installed

For more information visit [www.alpha.com](http://www.alpha.com)

# Appendix E

Calix E3-2 Module



**INTELLIGENT  
ACCESS** EDGE

**Calix E3-2**

**AXOS Release 21.1**

# Product Planning Guide

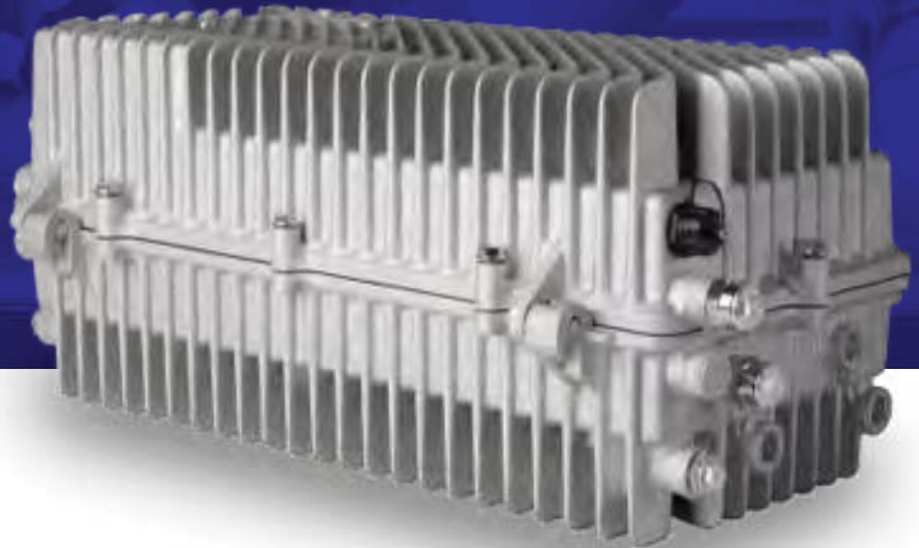

**NO:** CAB-21-004

**DATE:** February 2021

**ORIG:** PLL

**DIST:** External

The information contained in this document is not a commitment, promise or legal obligation to deliver any material, code or functionality. The development, release, and timing of any features or functionality described for our products remains at our sole discretion.

© 2020 Calix | Calix confidential and proprietary

# Table of Contents

|  |    |
|--|----|
| Calix E3-2 AXOS Release 21.1 Overview .....  | 4  |
| E3-2 Solution Overview .....   | 5  |
| Physical Attributes .....  | 6  |
| E3-2 Modules .....   | 9  |
| Interface Modules .....  | 9  |
| WAN Modules .....  | 10 |
| Control Modules .....  | 11 |
| Switch Modules .....   | 12 |
| E3-2 Module Compatibility .....  | 12 |
| Environmental Alarm Support .....  | 13 |
| Powering Options .....   | 14 |
| -48VDC Powering .....  | 14 |
| Battery Backup .....   | 15 |
| Coaxial Input Powering .....   | 15 |
| Line Powering .....  | 16 |
| Mounting Options .....   | 17 |
| Strand Mount .....   | 17 |
| Pole/Wall Mount .....  | 18 |
| Pedestal Mount .....   | 18 |
| Fiber Routing .....  | 19 |
| Connecting Fibers Using the Calix Fiber Pigtail Cable .....  | 19 |
| Connecting Fibers without Connectors .....   | 20 |
| Desiccant for Moisture Control .....   | 20 |
| Supported Applications .....   | 21 |
| Layer 2 residential triple-play GPON or XGS-PON services using a<br>switched (VLAN) transport network .....                  | 22 |
| Layer 2 GPON, XGS-PON or 10G EPON business services using a<br>switched (VLAN) transport network .....                       | 23 |
| T1 PWE support via GPON .....  | 23 |
| Connecting to E5-306 and E5-308 systems via GPON .....   | 24 |
| Layer 2 GPON and XGS-PON services using a single E3-2 .....  | 26 |
| Layer 3 classification of GPON, XGS-PON, or 10G EPON residential<br>services using a switched (VLAN) transport network ..... | 28 |

|  |    |
|--|----|
| Layer 3 classification of GPON or 10G EPON residential data service using a routed transport network ..... | 29 |
| New features in AXOS-R21.1 .....   | 31 |
| IPFix Enhancements .....   | 31 |
| SNMP MIB Enhancements .....  | 32 |
| GP1100X Enhancements .....   | 32 |
| Software Image Management Enhancements .....   | 33 |
| AXOS Always On Upgrades .....  | 33 |
| Specifications .....   | 37 |
| Ethernet Switching Capacity .....  | 37 |
| PON Capacity .....   | 37 |
| Layer 3 Capacity .....   | 38 |
| Protocols and Standards Supported .....  | 39 |
| XGS-PON ONT Support .....  | 39 |
| DOCSIS Management Support using DPx .....  | 40 |
| E3-2 Ordering Information .....  | 41 |
| CALIX E3-2 GPON PACKAGES .....   | 41 |
| CALIX E3-2 XGS-PON PACKAGES .....  | 42 |
| CALIX E3-2 10G EPON PACKAGES .....   | 43 |
| CALIX OPTICAL PLUGGABLE MODULES .....  | 45 |



## Calix E3-2 AXOS Release 21.1 Overview

AXOS Release 21.1 introduces enhancements to the E3-2 including:

- **IPFIX enhancements.** IPFIX is a protocol for streaming OLT and ONT statistics to an external IPFIX data collector. To increase your ability to monitor the E3-2 system remotely, this release increases the number of OLT and ONT data statistics that can be reported via IPFIX. In addition, support is provided for UDP format collectors.
- **SNMP enhancements.** This release introduces additional SNMP capabilities expanding the ability to monitor system status and performance statistics.
- **GP1100X enhancements.** OLT support is included for new GP1100X capabilities. This includes support for two additional voice protocols (H.248 and MGCP), and 802.1ag CFM (CCMs, Loopback, Link Trace).
- **Improved software image management for new hardware.** This release introduces a new Factory Default Image that is shipped on all new E3-2 systems and Control Modules. This simplifies software version management on spares and eliminates potential software compatibility issues.
- **AXOS always on upgrades.** This feature provides the ability to upgrade individual AXOS components without requiring a full system reboot. This results in an “always on” experience where individual AXOS components can be upgraded to correct a field issue without requiring a maintenance window.

Calix E3-2 AXOS Release 21.1 is supported by Calix SMx Release 21.1 and Calix DPx Release 21.1.

Please note that this Product Planning Guide builds upon previous product planning guides released for earlier E3-2 AXOS releases. Refer to those documents for information on E3-2 functionality in prior release.

*NOTE: AXOS Release 21.1 also provides support for E7-2 and E9-2 systems. Please refer to the Calix E7-2 AXOS Release 21.1 PPG, Calix E9-2 AXOS Release 21.1 PPG, and Calix E9-2 ASM AXOS Release 21.1 PPG for information related to those products.*

## E3-2 Solution Overview

The E3-2 features an environmentally hardened, modular “deploy anywhere design”. The E3-2 does not require active cooling, making it a perfect solution for outside plant (OSP) deployments. The E3-2 can be mounted aurally, on a pole, on a wall, or in a pedestal. This first of its kind system establishes a new intelligent strategic location in the network, allowing the E3-2 to move the OLT, routing, and IP policy and accounting functions from the headend toward the subscriber, thereby extending the reach of edge functionality from the data center. This distributed intelligence model, combined with the extended reach of fiber technologies, can eliminate the need to expand existing facilities or facilitate the consolidation and collapse of expensive existing facilities.

Powered by AXOS, the E3-2 delivers on the promise of Software Defined Access (SDA). Its “always on” stateful operation allows operators to deploy independently rich software features deep into the network, while using the zero-touch activation and nodal management capabilities of AXOS and SMx to “simplify” system and network management. The E3-2 modular software facilitates virtualized architectures in an SDN multi-vendor, multi-technology environment further reducing operational complexities and providing a rich alternative to Distributed Converged Cable Access Platform (D-CCAP).

In addition to support for Layer 2 PON functionality using VLANs, the E3-2 can optionally support fully integrated Layer 3 capabilities. This enables support for Layer 3 dynamic routing protocols and Layer 3 subscriber management capabilities, greatly expanding the intelligence available in the access network and eliminating the need for aggregation routers. Additionally, support for both Layer 2 and Layer 3 capabilities in a single form factor can facilitate for the first time the collapse of these networks into one unified PON solution.

The system is fully upgradable, enabling rapid migration to 10Gbps PON services and beyond. Every module in the E3-2 can be easily and quickly removed and replaced in the field, providing a completely field serviceable solution. By replacing one or both subscriber interface modules, you can migrate your network to 10 Gbps PON services and beyond without replacing every module, enabling a cost-effective and future-proof solution. As the power supply units are also modular, the E3-2 supports multiple powering options allowing complete flexibility to support your power needs. For traditional telco powering where battery backup is desired, the E3-2 supports -48VDC. Battery backup can be provided with an external Alpha power supply. For typical MSO outside plant applications, the Calix E3-2 Intelligent PON Node supports existing cable plant powering: coaxial square wave input from 60VAC to 90VAC. Additional powering options include support for commercial AC, and +/-190VDC span power through an external Alpha power supply.

## Physical Attributes

The E3-2 contains replaceable and upgradeable modules and transport interfaces as well as accommodates the fiber management for pre-connectorized service cables. The E3-2 also contains the redundant power supply and additional electronic components associated with the unit. The Calix E3-2 has the following physical attributes:

- **Network Interfaces:**
  - 4 x 10GE 10 Gigabit small form-factor pluggable (XFP or SFP+) sockets for 10GE uplinks and/or subtending downlinks. The units can participate in Layer 3 routed networks as well as daisy chain or ring using Layer 2 standards such as G.8032v2 and LAG, allowing connection to other Calix E-Series and C-Series products.
- **Subscriber Interfaces:**
  - GPON: 4 x GPON interfaces per GP401 module (8 total GPON interfaces per E3-2)
  - XGS-PON: 2 x XGS-PON interfaces per NG201 module (4 total XGS-PON interfaces per E3-2)
  - 10G EPON: 2 x 10G EPON interfaces per XEP201 module (4 total 10G EPON interfaces per E3-2)
- **Environmental Alarm Inputs:** 4 input alarms
- **Power Feeds:** 60VAC/90VAC coax power, -48VDC, Commercial AC (110/220VAC), or Line Powering (+/-190VDC) using an external sealed Line Powering option
- **Operating Environment:** The E3-2 is environmentally sealed and hardened, supporting an operational temperature range of -40 °C to +65 °C with humidity of 5% to 95% (non-condensing).
- **Dimensions:** 9.65" x 11.5" x 22" (24.5 cm x 29.2 cm x 55.9 cm)

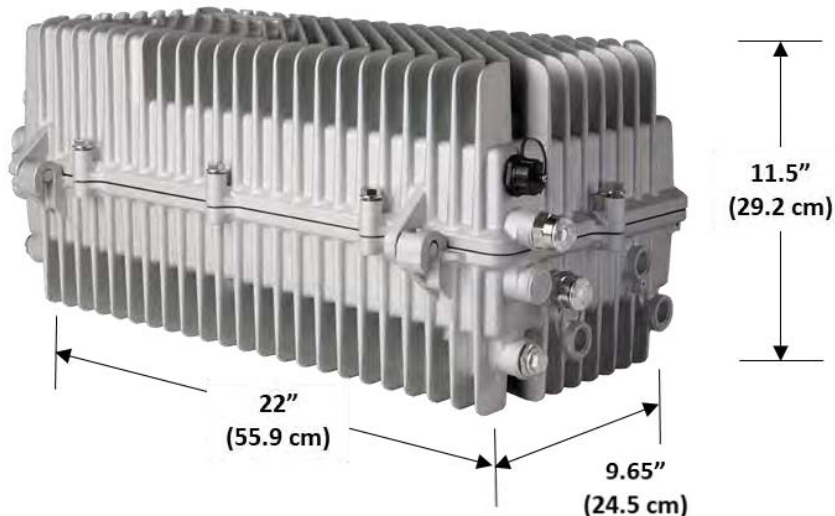

Figure 1. E3-2 dimensions

- Physical Enclosure:** The E3-2 is a sealed enclosure that easily integrates into outside plant deployments. The unit consists of a ruggedized aluminum housing with access ports for incoming power and fiber connections, as well as an externally accessible USB management port. Fiber and power connections can be input from either side of the E3-2, providing flexibility for different network deployments. The USB port connection is only present on the right side of the enclosure. Externally accessible ports are shown in the figure below.



Figure 2. E3-2 right and left side view

The E3-2 enclosure has one opening on the left side and one on the right side for the fiber cable, giving the option for routing fiber through one or both openings. Calix provides an optional fiber cable accessory (100-04767) listed in the ordering section of this guide. The E3-2 has one opening on the left side and one on the right side for coaxial power entry, giving the option of routing power through either opening. Other powering options use a separate power entry port that allows easy access to the terminal block for wiring connections. When not being used, openings can be sealed using provided covers. The right side of the E3-2 includes covered access to a USB 2.0 port which can be utilized for external management access. If external management access is not desired, this port can be sealed, or the USB 2.0 port disconnected. Additional sealed openings are for future purposes.

The E3-2 supports multiple mounting options. For aerial (strand) mounting, clips are provided which allow for direct mounting to the strand. These clips can also be used when mounting within a pedestal enclosure. The mounting clips can be adjusted using a standard one-half inch bolt. For pole or wall mounting, screw holes are provided on the lid of the enclosure. Please refer to the mounting options section of this guide for additional information.

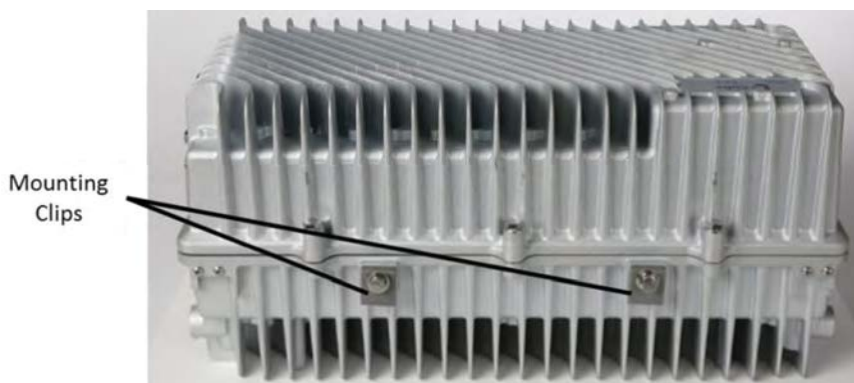

Figure 3. E3-2 mounting clips for aerial (strand) and pedestal mounting

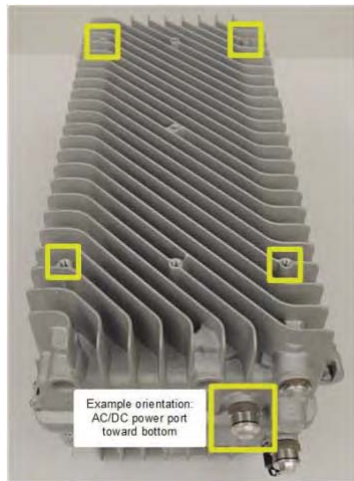

Figure 4. E3-2 pole/wall mounting screw holes

To secure the E3-2 and maintain the seal, 8 spring-loaded tightening bolts are provided. Each bolt is a standard one-half inch hex bolt. When sealed, the Calix E3-2 exceeds IP 67 requirements, meaning that it can withstand immersion in water at a depth of 1 meter for more than thirty minutes. However, the Calix E3-2 is not designed to be deployed in areas where it will remain immersed in water for prolonged periods of time.

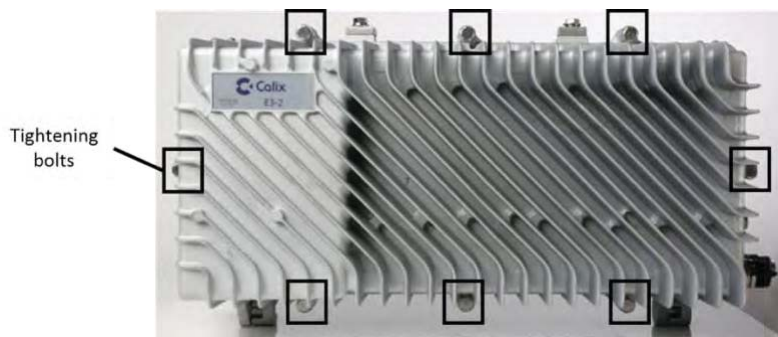

Figure 5. E3-2 tightening bolts

## E3-2 Modules

Every module within the E3-2 is field-serviceable and upgradable, providing a very flexible and future-proof system. The following diagram shows the internal components of the E3-2:

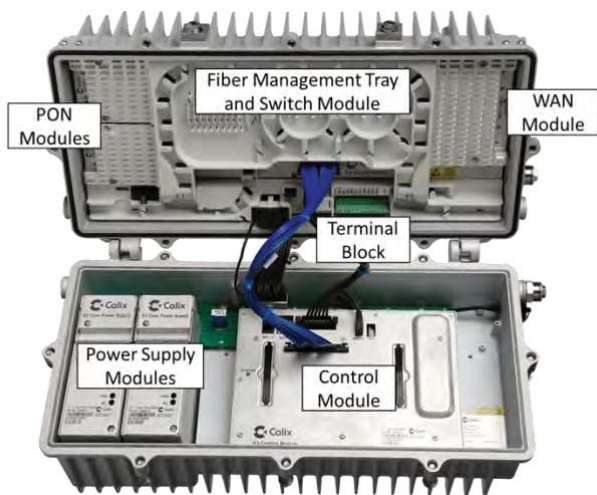

Figure 6. E3-2 interior view

## Interface Modules

The E3-2 can contain up to two interface modules for connection toward subscriber interfaces.

### NG201 XGS-PON/NG-PON2 Interface Module

The NG201 GPON Module provides two ports of 10 Gigabit PON and is capable of either XGS-PON or NG-PON2. Support for NG-PON2 requires hardened NG-PON2 optics, which are not currently available. Therefore, in this release this module supports XGS-PON. Each port can subtend up to 128 ONTs. This provides a capacity of 256 ONTs per NG201 module, and 512 ONTs per E3-2 if two NG201 modules are used. Each XGS-PON/NG-PON2 port has the following characteristics:

- Supports two XFP ports of XGS-PON/NG-PON2
- Based on the ITU G.989 NG-PON2 and XGS-PON family of standards
- Supports PON rates of 9.953 Gbps downstream, 9.953 Gbps upstream
- Supports XGS-PON optics initially, with support for up to 2 TWDM NG-PON2 wavelengths (one per physical port) in the future
- Interoperable with the Calix family of next-generation 10G PON residential SFUs and MDUs as well as Business ONTs
- Class N1 ODN support, +29 dB link budget
- Supports AES encryption

### GP401 GPON Interface Module

The GP401 GPON Module provides four ports of GPON. Each port can subtend up to 64 ONTs in AXOS-R21.1.0, with expansion to 128 ONTs per PON port in a future



Figure 7. XP201 XGS-PON/NG-PON2 interface module

release. This provides a capacity of 256 ONTs per GP401 modules, and 512 ONTs per E3-2 if two GP401 modules are used. Each GPON port has the following characteristics:

- Based on the ITU G.984 GPON family of standards
- Supports GPON rates of 2.488 Gbps downstream, 1.244 Gbps upstream
- Interoperable with the Calix family of ONTs
- Class B+ ODN support, +28 dB link budget, up to 20 km at 32-way splits
- Class C+ ODN support, +32 dB link budget with Forward Error Correction (FEC), up to 32 km at 32-way splits
- Supports AES encryption
- A GP401 interface module cannot co-exist with an XEP201 in the same E3-2 system
- The GP401 interface module requires use of the RSX3001 switch module

#### XEP201 10G EPON Interface Module

The XEP201 10G EPON Module provides two ports of 10 Gigabit EPON. Each port can subtend up to 128 ONTs. This provides a capacity of 256 ONTs per XEP201 modules and 512 ONTs per E3-2 if two XEP201 modules are used. Each 10G EPON port has the following characteristics:

- Supports two XFP ports of 10G EPON
- Based on the IEEE 802.3 family of standards
- Each PON port supports symmetric 10G EPON (10.3125 Gbps downstream, 10.3125 Gbps upstream)
- Interoperable with Calix 10G EPON ONUs, as well as third-party DPoE-compliant ONUs. Contact Calix for additional information on third-party ONU interoperability
- An XEP201 interface module cannot co-exist with a GP401 or NG201 in the same E3-2 system
- The XEP201 interface module requires use of the RSX3001E or RSX3101E switch module

#### WAN Modules

The E3-2 has a single WAN module slot for supporting uplink and transport. Two WAN module options are available with AXOS Release 21.1: XE401 and XE401S.



Figure 8. GP401 GPON interface module



Figure 9. XEP201 10G EPON interface module

### XE401 WAN Module with XFP Interfaces

The XE401 module provides four ports of 10GE for use as uplink and transport bandwidth. Although only one port is required for operation, the four ports allow for a maximum of 40 Gbps of uplink capacity, allowing for non-blocking transport even when the E3-2 is populated with 10G PON. The four ports also allow for a variety of uplink redundancy including LAG, RSTP, ERPS, and G.8032v2.

### XE401S WAN Module with SFP+ Interfaces

The XE401S (part #100-05288) provides four 10GE ports for use as transport. This module supports all use cases (both GPON and 10G EPON) and switch module types. The XE401S accepts SFP+ optical modules as specified in the Calix Optical Transceiver Modules Datasheet (#250-00191).

## Control Modules

The E3-2 supports a single Control module slot. Two Control Module options are available in AXOS Release 21.1: RCX3001 and RCX3101.

### RCX3001

The RCX3001 provides the control functionality for the system, as well as the management interfaces. The following physical management interfaces are supported:

- One RS-232 Serial (RJ-11) interface
- One 10/100 Ethernet (RJ-45) interface
- One USB interface. This interface can optionally be routed to an external port, allowing management access to the system without opening the E3-2.

### RCX3101

For some customers, the E3-2 is deployed in a non-secured location within the network. Although access to local management port may be necessary, the requirement is to prevent unauthorized access that cannot be detected. For these customers, the E3-2 supports the RCX3101 (part #100-05287). The RCX3101 is very similar to the RCX3001 control module but provides an additional security plate to restrict access to local management ports. As with the RCX3001, this module supports all E3-2 use cases (both GPON and 10G EPON) and switch module types.

The RCX3101 provides the control functionality for the system. In typical installations, the local management ports are inaccessible as they are covered with a security plate. If access to the local management ports is required, then the security plate can be removed. This requires removal of the power cable prior to removal of the security plate.



Figure 10. XE401 10G WAN uplink and transport module



Figure 11. 10G WAN module



Figure 12. RCX3001 control



## Switch Modules

The E3-2 contains a single Switch Module slot. For GPON applications, there is one Switch Module option available: the RSX3001. For 10G EPON applications, there are two Switch Module options available: RSX3001E and RSX3101E.

### RSX3001

The RSX3001 provides a Layer 2 and Layer 3 switching module capable of supporting the following interface module types:

- GP401 GPON interface module

The RSX3001 does not provide support for XEP201 10G EPON interface modules.

### RSX3001E

The RSX3001E provides a Layer 2 and Layer 3 switching module capable of supporting the following interface module types:

- XEP201 10G EPON interface module

*Note that the RSX3001E is required for use with the XEP201 interface modules. The RSX3001E does not provide support for GP401 or NG201 interface modules.*

### RSX3101E

Some customers wish to provide additional security on traffic transmitted from the E3-2 to the network using encryption on the 10GE uplinks. For those customers, the E3-2 supports the RSX3101E (part #100-05289). The RSX3101E provides a Layer 2 and Layer 3 switching module capable of supporting the following interface module types:

- XEP201 10G EPON interface module

In addition to providing switching functionality for the system, the RSX3101E incorporates an additional chip enabling line-rate support for MACsec on the network uplinks.

*Note: MACsec capability can be either enabled or disabled through system software commands. Therefore, the RSX3101E can support applications without MACsec requirements as well as applications with MACsec requirements.*



Figure 13. RSX3001 switch module



Figure 14. RSX3001E 10G EPON switch module



Figure 15. RSX3101E 10G EPON switch module

## E3-2 Module Compatibility

The E3-2 support the ability to mix module types, providing flexibility to support multiple network configurations within a single system.

The following table illustrates module compatibility:

|                       |        | Switch Modules |         |         | PON Interface Modules |        |       | WAN Modules |        | Control Modules |         |
|-----------------------|--------|----------------|---------|---------|-----------------------|--------|-------|-------------|--------|-----------------|---------|
|                       |        | RSX3001        | RX3001E | RX3101E | GP401                 | XEP401 | NG201 | XE401       | XE401S | RCX3001         | RCX3101 |
| PON Interface Modules | GP401  | Yes            | No      | No      | Yes                   | No     | Yes   | Yes         | Yes    | Yes             | Yes     |
|                       | XEP401 | No             | Yes     | Yes     | No                    | Yes    | No    | Yes         | Yes    | Yes             | Yes     |
|                       | NG201  | Yes            | No      | No      | Yes                   | No     | Yes   | Yes         | Yes    | Yes             | Yes     |

Figure 16. E3-2 module compatibility

## Environmental Alarm Support

The E3-2 supports contacts for four environmental alarms. One of these alarms is pre-wired for the E3-2 enclosure open alarm, allowing remote monitoring of the status of the E3-2 enclosure. The other three sets of alarm contacts allow for user-defined alarms. A typical use of these alarm contacts is to monitor the status of the external power source (e.g., an Alpha power supply).



Figure 17. Figure 15 - E3-2 Terminal Block with Environmental Alarm Contacts

## Powering Options

The E3-2 supports a variety of powering options, giving a network provider complete flexibility to use whatever powering option is available at a given location. Any powering option can be used with any combination of modules installed in the E3-2. The following sections describe the different powering options.

### -48VDC Powering

The E3-2 can be powered with a -48VDC input signal. As the E3-2 natively operates using -48VDC, there is no additional power module required to be inserted. In this case, the power module slots can remain empty. A power/alarm cable (part #100-04589) is used to connect to the terminal block on the base of the unit, as shown in the figure below.

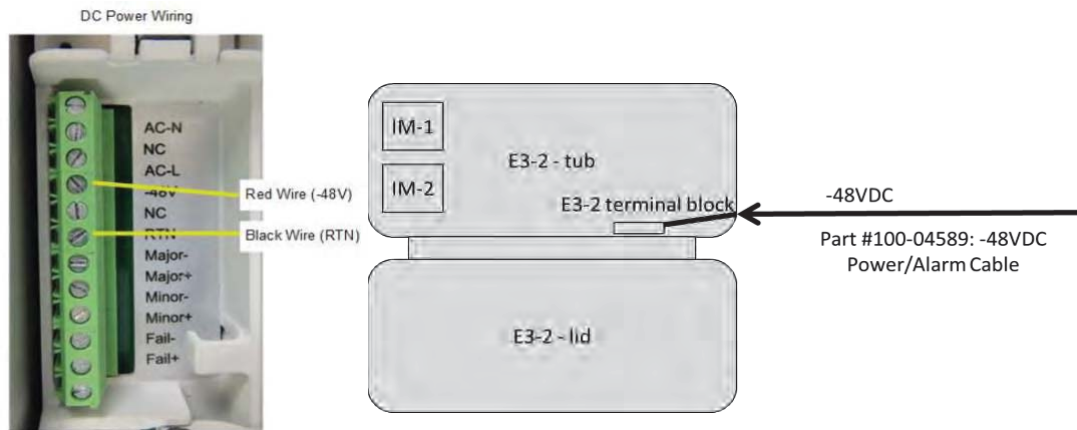

Figure 18. 48VDC powering for the E3-2

Using -48VDC powering, a network provider can take advantage of existing options for providing battery-backup. Please contact Calix for recommendations on external battery backup systems that are appropriate for the E3-2.

## Battery Backup

When using -48VDC powering, a network provider can take advantage of existing options for providing battery-backup. The E3-2 requires typical maximum powering of less than 100 Watts, but Calix recommends that an external Alpha supply be used with 150 Watts of capacity. The FlexNet FMPS Multipurpose Power Supply (Alpha part number 010-592-20-053, Calix part number 100-02224) provides 150 Watts of capacity and supports individually monitored 48Vdc strings of standard 7Ah to 8Ah VRLA batteries for standby power (part number 100-01565). Telemetry for alarms can be carried to the E3-2 using the E3-2 -48VDC power/alarm cable, part number 100-04589.

Battery backup parts can be ordered from Calix or direct from Alpha. Please send Alpha orders to Alpha Technologies Ltd. by email at [orderpo@alpha.ca](mailto:orderpo@alpha.ca) or by fax at (604) 638-8698.



Figure 17 - 010-592-20-053 FlexNet FMPS, 120V Line cord, 150W, 48Vdc out, -40°C (-40°F)

## Coaxial Input Powering

Typical Cable MSO OSP deployments use coax to provide 60VAC or 90VAC power to remote nodes. When using coaxial input powering, the coax is connected to a coax connector ("stinger") that is inserted in the coax power entry port located on either the right side or the left side of the E3-2. Internally, the E3-2 converts the 60VAC/90VAC to -48VDC using the RPS1000CX power supply module. Although only one RPS1000CX is required to power the system, for redundancy, the user may optionally equip the E3-2 with a second RPS1000CX. The following diagram shows an example of coax powering on the E3-2.

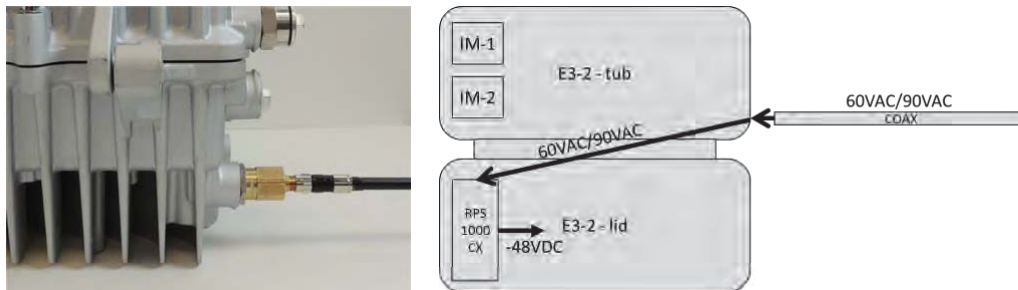

Figure 19. Coaxial input powering for the E3-2

The E3-2 can be powered with a 110V/220V input signal. For this powering option, the Commercial AC signal is connected to the power terminal ports in the E3-2 using the E3-2 AC Power/Alarm Cable (part #100-04585), as shown in the figure below. Inside the E3-2, the AC signal is converted to -48VDC using the RPS1000AX power supply. Although only one RPS1000AX is required to power the system, for redundancy, the user may optionally equip the E3-2 with a second RPS1000AX.

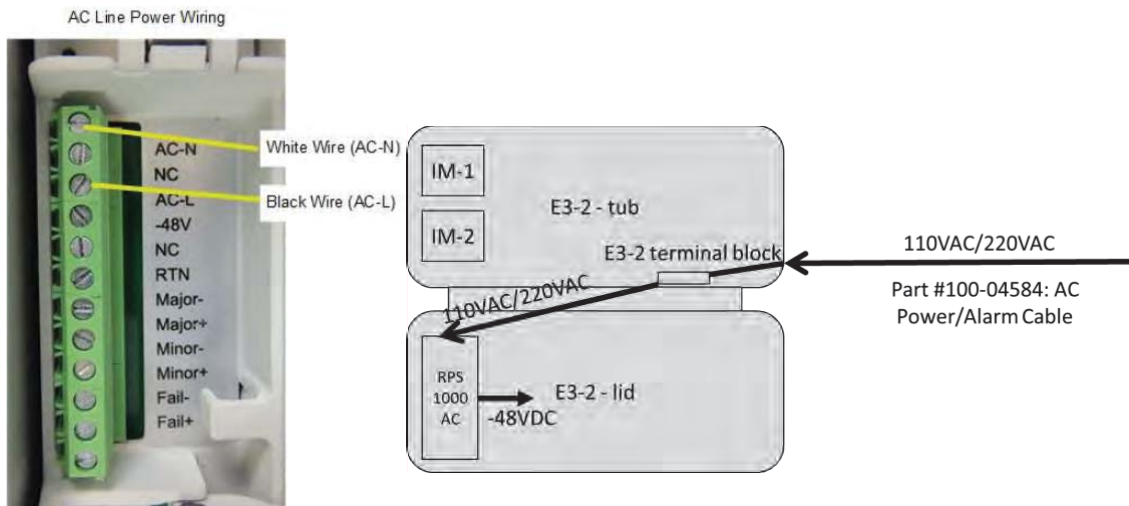

Figure 20. AC powering for the E3-2

## Line Powering

The E3-2 can be powered using +/-190VDC twisted pairs (span powering). Support for line powering is provided through an external sealed line powering unit. The E3-2 requires typical maximum powering of less than 100 Watts, but Calix recommends that an external Alpha supply be used with 150 Watts of capacity. Calix recommends the LPR12/48-150-IP68 Line Powering Remote Downconverter Unit. This unit converts the +/-190VDC signal received via twisted copper pairs to -48VDC, which is then carried into the E3-2 via the -48VDC power/alarm cable (part #100-04589). Telemetry for alarms can be carried to the E3-2 using this cable.

The following manufacturer part numbers are readily available from Alpha and should be ordered direct from Alpha. Please send all orders to Alpha Technologies Ltd. by email at [orderpo@alpha.ca](mailto:orderpo@alpha.ca) or by fax at (604) 638-8698.

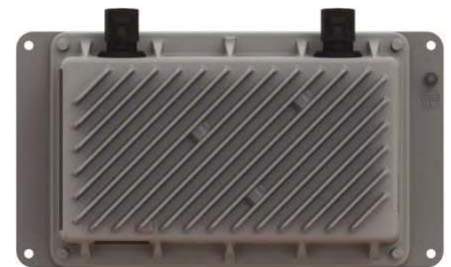

Figure 21. 0120057-001  
LPR12/48-150-IP68 +/-  
190Vdc to 12 or 48Vdc Line  
Powering Remote  
Downconverter Unit

## Mounting Options

The E3 is environmentally hardened and designed to be mounted anywhere. The E3-2 supports the following mounting options:

- Strand-mount
- Pole/wall mount
- Pedestal mount

### Strand Mount

The E3-2 can be aerially mounted using the attached mounting clips. These mounting clips are always included with the E3-2, and therefore there is no need to order an additional part to support this mounting option.



Figure 22. Strand mounted E3-2

## Pole/Wall Mount

The E3-2 supports mounting on a pole or wall. For this option, order the E3-2 Pole/Wall Mount Installation Kit (part number 100-04590).



Figure 23. Figure 22 - Pole/wall mount option

## Pedestal Mount

When mounting in a pedestal, the E3-2 can be attached to the mounting bar using the attached clips. It is not necessary to order any additional mounting hardware.



Figure 24. Pedestal mount option

## Fiber Routing

Fiber can be routed through the E3-2 in one of two ways:

- Using the Calix fiber pigtail cable (part number 100-04767) which comes with fiber connectors attached
- Using incoming fiber without connectors and performing splicing to fibers with connectors inside the E3-2

### Connecting Fibers Using the Calix Fiber Pigtail Cable

The Calix Fiber Pigtail Cable (part number 100-04767) is a 20' fiber pigtail which has connectors on one end and bare fiber on the other. The connectorized end is designed for insertion into the E3-2, and contains the following:

- 9 fibers with SC/UPC connectors
- 9 fibers with LC/UPC connectors

When equipped with 8 ports of GPON, the E3-2 requires 8 fibers with SC/UPC connectors, so the fiber cable includes a spare SC/UPC fiber. When equipped with 4 10GE uplink ports, the E3-2 requires 8 fibers with LC/UPC connectors. Therefore, the fiber cable also includes a spare LC/UPC fiber.

The connectorized end of the fiber cable includes a feed-thru adapter nut which connects to the fiber access port on the E3-2. The fibers are then routed through the fiber tray (see figure below) and then routed using the build-in guides on the Switch module to connect to the Interface Modules and WAN module. The following diagrams show the fiber routing using the Calix Fiber Pigtail cable:

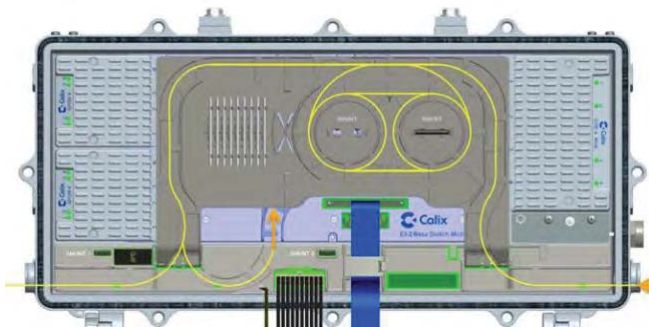

Figure 25. Fiber routing from the fiber access port to the fiber tray

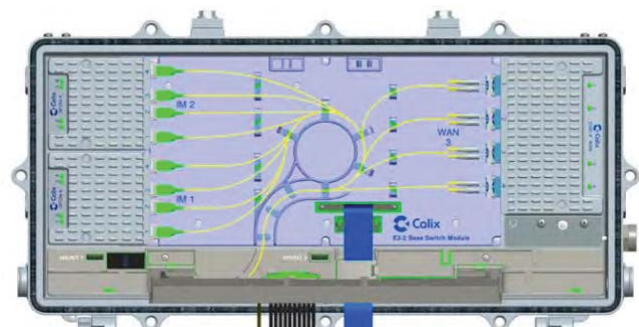

Figure 26. Figure 25 - Fiber routing from the fiber tray to the E3-2 modules



## Connecting Fibers without Connectors

When using fibers that do not have connectors, the incoming fibers are routed to the fiber tray where splicing can be done to a fiber segment with connectors. The splice fiber with connectors is then routed using the built-in guide trays on the switch module to the Interface Modules and WAN module. As stated above, when equipped with 8 ports of GPON, the E3-2 requires 8 fibers with SC/UPC connectors and 8 fibers with LC/UPC connectors. The following diagrams show the fiber routing for incoming fiber without connectors:

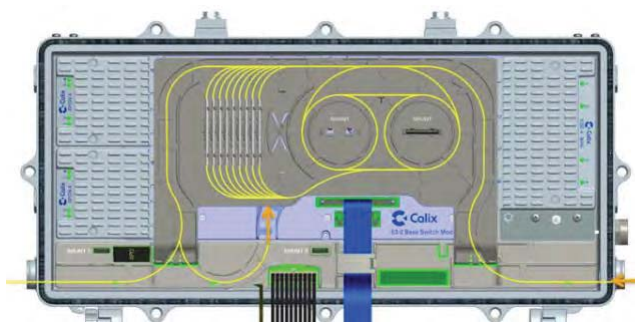

Figure 27. Fiber routing from the fiber access port to the fiber tray

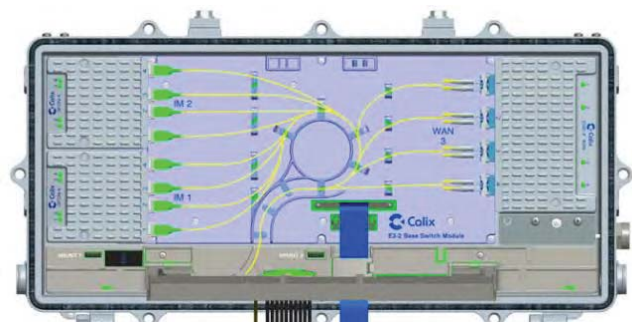

Figure 28. Fiber routing from the fiber tray to the E3-2

## Desiccant for Moisture Control

When closed, the E3-2 is sealed to prevent moisture from entering the system. However, it is possible for moisture to get sealed inside the E3-2 during installation or servicing. To address this, Calix factory-installs desiccant inside each E3-2 enclosure before shipping. Using the desiccant is very important to ensure that any moisture that may gather from high humidity when you open and close the E3-2 enclosure does not persist, as moisture can possibly damage the electronic components. The desiccant must not be removed and should be periodically replaced or refreshed to maintain effectiveness.

Ensure that the factory-installed desiccant remains inside the E3-2 enclosure when installed. Do not remove the desiccant during the installation process.

Desiccant eventually loses effectiveness as it absorbs moisture and must be periodically maintained. Monitor its status and replace/refresh the desiccant as required, per the following guidance:

- **Early E3-2 versions:** The factory-supplied desiccant is a bag that sits loose inside the enclosure. Check the bag for moisture. If there is any detectable moisture, its effectiveness has been exhausted and it should be replaced.
- **Later E3-2 versions:** The factory-supplied desiccant sits inside a reusable plastic module attached to the inside wall of the enclosure with velcro. The desiccant module has an indicator that changes color from blue to pink when it needs to be replaced. Check the module periodically and replace when pink. Desiccant replacement kits are available from Calix using part #120-00387.



## Supported Applications

The Calix E3-2 Intelligent PON Node supports both Layer 2 and Layer 3 applications, as well as both GPON, XGS-PON and 10G EPON applications. The following applications are supported in this release:

- Layer 2 residential triple-play GPON or XGS-PON services using a switched (VLAN) transport network
- Layer 2 GPON, XGS-PON or 10G EPON business services using a switched (VLAN) transport network
- Layer 2 GPON and XGS-PON support for residential and business services within a single E3-2 using a switched (VLAN) transport network
- Layer 3 classification of GPON, XGS-PON, and 10G EPON residential services using a switched (VLAN) transport network
- Layer 3 classification of GPON or 10G EPON residential data service using a routed transport network (OSPF, IS-IS, I-BGP)

The following sections define the services and applications for AXOS Release 21.1.

## Layer 2 residential triple-play GPON or XGS-PON services using a switched (VLAN) transport network

PON networks can provide cost-effective high-speed fiber triple-play residential services. High Speed Internet (HSI) service is typically provided using N:1 VLANs. Multiple voice options are available including SIP, H.248, MGCP and TDM Gateway. Please note that not all ONT types support voice ports. Video service can be provided using IPTV (multicast or unicast) or RF Video. If RF video is used, then either an external micronode or a compatible ONT must be used at the customer premise to separate the RF overlay wavelengths.

To enhance security, the E3-2 supports security features for this application including:

- DHCP Snoop, along with MAC Forced Forwarding (MACFF) and IP Source Verification (IPSV)
- DHCP Relay Option 82
- DHCP Proxy

Example GPON triple-play service applications are shown below:

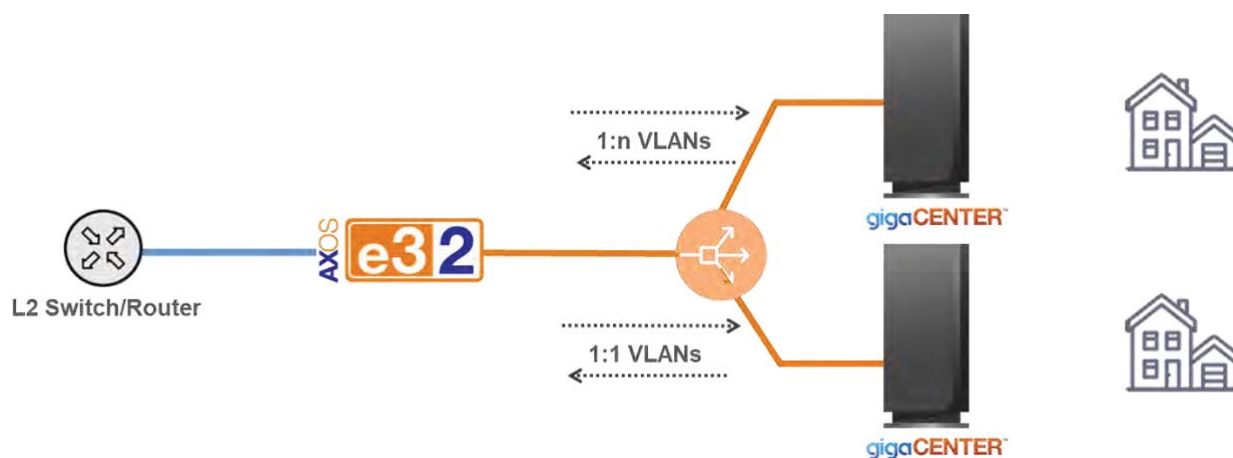

Figure 29. Layer 2 triple-play services (voice, video, data)

**NOTE:** In this release an E3-2 can support either XGS-PON (using the NG201) or GPON (using the GP401) but cannot support both simultaneously. Support for GPON and XGS-PON within a single E3-2 will be provided in a future release.

## Layer 2 GPON, XGS-PON or 10G EPON business services using a switched (VLAN) transport network



- Solution Attributes:**
- ✦ E-LINE
  - ✦ LAG, G.8032, or ERPS for uplink redundancy
  - ✦ SIP Voice
  - ✦ IPv4 and IPv6 HSI (E-LINE)

Figure 30. Layer 2 GPON, XGS-PON (or 10G EPON) Business E-LINE Data Service and VoIP Service

AXOS Release 21.1 supports E-LINE, a Layer 2 data service for transporting a data service transparently through the network. An E-LINE is a service type defined by the MEF for connecting two UNIs where those two UNIs can communicate only with one another. E-LINES are defined in Metro Ethernet Forum standards MEF 6.2 and MEF 10.3. In this application, the E3-2 operates using a traditional Layer 2 VLAN model. Voice services (either SIP or MGCP) can be provided through VoIP.

Notes regarding this application:

- This service can be provided via GPON, XGS-PON or 10G EPON
- E-LINE service is a dedicated point-to-point service transported through the E3-2 using a VLAN per subscriber
- No security features are supported for this application (e.g., no MAC forced forwarding), as the E-LINE service is carried transparently through the network

### T1 PWE support via GPON

Business services can also be supported with T1 Pseudowire (PWE3) emulation when connected with the following Calix ONTs:

- 743GE
- 744GE
- 766GX
- 767GX

Because T1 services are traditionally TDM based (synchronous in nature), a means to transport these services over a packetized network (asynchronous) is needed. PWE3 is a standards-based (RFC3916) mechanism that emulates the essential attributes of Time Division Multiplex (TDM) services over a Public Switched Network (PSN) using Internet Protocol (IP) transport. A Pseudowire connects two TDM circuits over a packet switched Ethernet network. In the most basic example, two T1 endpoints are connected, converting a T1 signal into Ethernet frames and transported over an asynchronous Ethernet network. On the receiving end, the Ethernet frames are converted back to TDM T1 signaling.

## GPON PWE Support for the E3-2

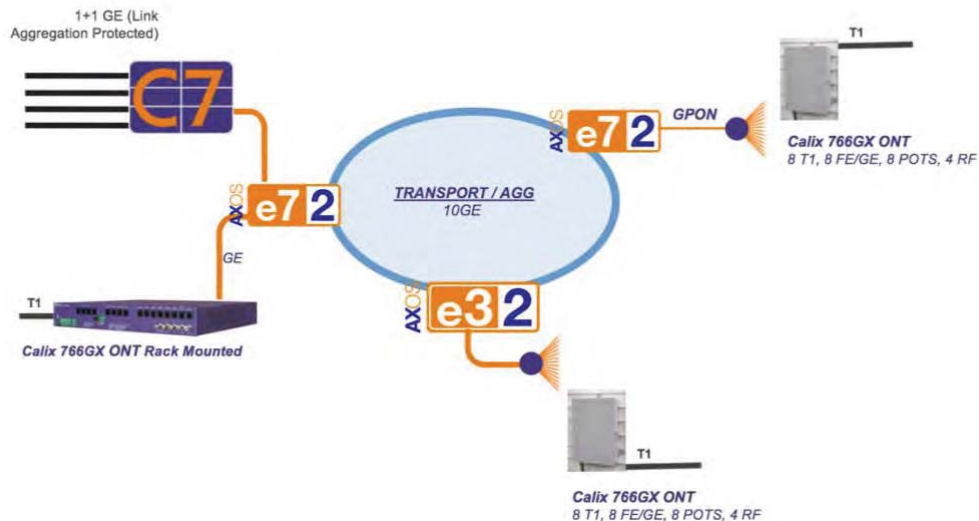

Figure 31. PWE3 application example

The figure above shows two typical applications of PWE3 support using the Calix E3-2. A T1 service is connected to the Calix 766GX ONT, where it is packetized and transmitted via PWE3 to the E3-2 over a GPON connection. The E3-2 transports the PWE3 packet stream through the network to the E3-2 at the headend, where there are two options for converting it back to a TDM-based T1. In the first option, the E3-2 connects via a GE port to a Calix C7, which converts the PWE3 packet stream back into a T1. This option can use any GE port on the Calix E3-2. The second option is to connect via a GE port to a second Calix 766GX ONT, providing a bookend solution.

*Note:* this option requires the use of Active Ethernet (AE) connection to the 766GX ONT at the central office.

For additional detail on PWE3 support within the E3-2, please refer to the *Calix T1 Pseudowire Applications Guide* (document number 220-00515), which is available on MyCalix.

### Connecting to E5-306 and E5-308 systems via GPON

The E3-2 can also support E5 Ethernet Business Service (EBS) units connected via GPON. AXOS Release 21.1 interoperates with the GPON Interface Adapter (GIA) that installs into the E5-306/308 for business services. The GIA is a single port GPON ONT in an SFP form factor. The GIA supports full GPON support enabling to business services. The services must be enabled as ELINE to ensure QoS.

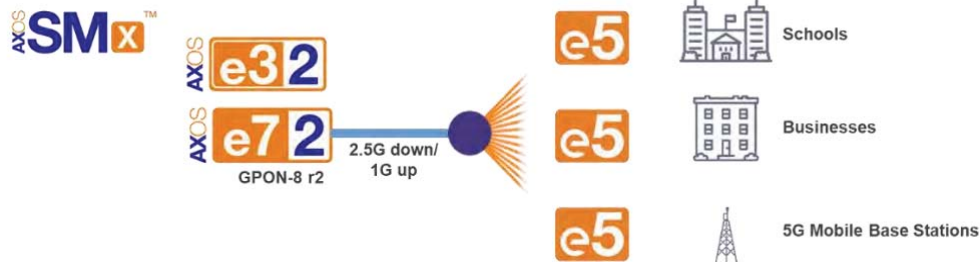

Figure 32. Connection of E5-306 and E5-308

Please reference the system documentation and Release Notes for additional detail and limitations of the current release.

## Layer 2 GPON and XGS-PON services using a single E3-2

AXOS Release 21.1 allows simultaneous support of GPON services (using the GP401 module) and XGS-PON services (using the NG201 module). Using this application, customers can support both business and residential services within a single E3-2. The GPON and XGS-PON services can be transmitted over separate Optical Distribution Networks (ODNs) or combined onto a single ODN using an external co-existence element to combine the GPON and XGS-PON wavelengths.

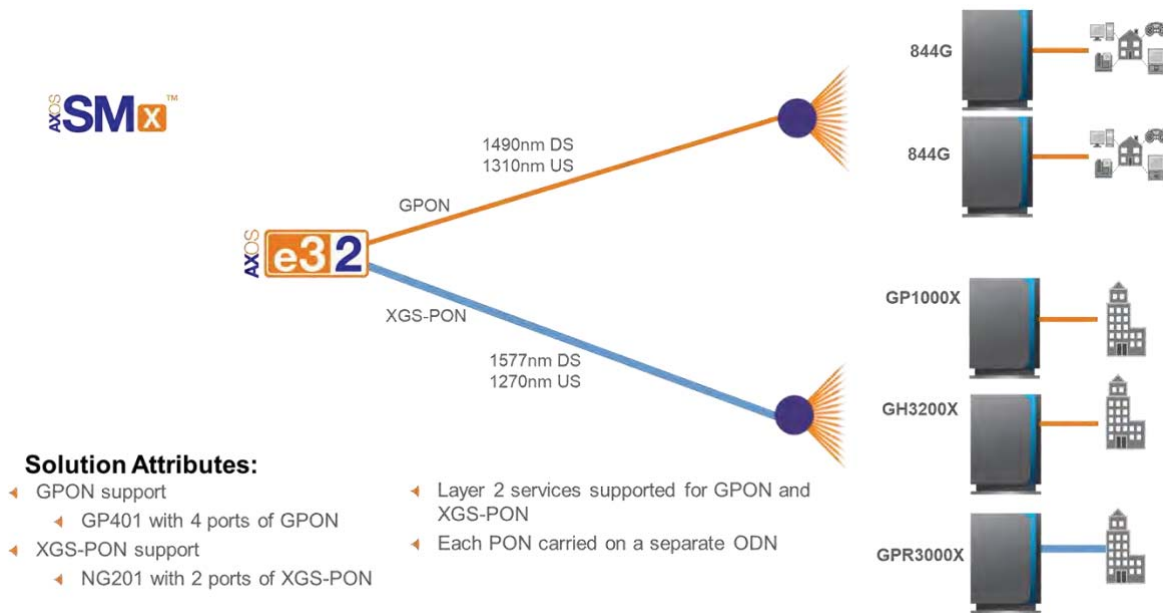

Figure 33. Simultaneous support of GPON and XGS-PON within an E3-2 – separate ODNs

ACOS SMx™

ACOS e32

GPON 1490nm DS  
1310nm US

XGS-PON 1577nm DS  
1270nm US

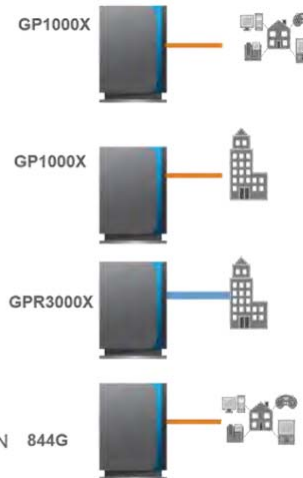

### Solution Attributes:

- ◀ GPON support
  - ◀ GP401 with 4 ports of GPON
- ◀ XGS-PON support
  - ◀ NG201 with 2 ports of XGS-PON
- ◀ External coexistence element
- ◀ Layer 2 services supported for both GPON 844G and XGS-PON

Figure 34. Support of GPON and XGS-PON within an E3-2 on a single ODN

**Note:** When converting an interface module slot between GPON and XGS-PON, a system reboot is required in order to load the appropriate PON MAC image for that interface module slot.

**Note:** If a system with only one installed interface module is upgraded to AXOS Release 21.1, the MAC for the empty interface module is configured for XGS-PON. If an NG201 module is inserted into the empty location, then a system reboot is not required. However, if a GPON module is inserted into the empty location then a reboot is required as described in the previous note.

The Coexistence Element is not sold by Calix. Calix recommends that CEs meet the requirements listed in Calix bulletin CAB-19-027. CE devices can be purchased directly from the following suppliers:

- Clearfield Inc.
  - [www.seeclearfield.com](http://www.seeclearfield.com)
  - Contact e-mail: [dfarr@clfd.net](mailto:dfarr@clfd.net)
- Corning Inc.
  - [www.corning.com](http://www.corning.com)
  - Contact e-mail: [LeyB@corning.com](mailto:LeyB@corning.com)
- Lambda Networks
  - [www.lambda.net](http://www.lambda.net)
  - Contact e-mail: [john@lambda.com](mailto:john@lambda.com)
- Montclair Fiber Optic Inc.
  - [www.montclairfiber.com](http://www.montclairfiber.com)
  - Contact e-mail: [kthompson@montclairfiber.com](mailto:kthompson@montclairfiber.com)
- Optiworks Inc.
  - [www.optiworks.com](http://www.optiworks.com)
  - Contact e-mail: [yanyan\\_ma@optiworks.com](mailto:yanyan_ma@optiworks.com)

To prevent interference from XGS-PON or NG-PON2 wavelengths, GPON ONTs must filter out unwanted wavelengths. For Calix GPON ONTs deployed since 2012, this filter is built-in. If the filter is not built-in, then an external filter is required. The following guidelines apply:

- All GigaFamily products have the filter built-in
- 700GE and 836GE ONTs have the filter built-in
- 700GX and 760GX ONTs have the filter built-in if produced in 2012 or later



If you have any questions regarding the compatibility of your existing GPON ONTs with XGS-PON or NG-PON2 deployments, please contact your Calix representative. The compatibility can be verified using the CLEI codes.

| NEXT GEN STANDARD | CALIX ONTS 500S, 700S, 700GS, 2300S, 2400S, T-063, T-076G, T077G, T-710G-24, T-720G-24 | CALIX ONTS T071G, T072G, T073G | CALIX ONTS 740G, 765G, 700GX, 760GX | CALIX ONTS GIGACENTERS, GIGAHUBS, GIGAPOINTS, 700GE, 740GE, 836GE |
|-------------------|--|--------------------------------|-------------------------------------|---|
| XGS-PON           | Requires external filters  | Coexistence                    | Coexistence if shipped after 2011   | Coexistence   |

Figure 35. Coexistence of Calix GPON ONTs with XGS-PON

## Layer 3 classification of GPON, XGS-PON, or 10G EPON residential services using a switched (VLAN) transport network

This application is typically associated with deployments in Cable MSOs. In this application, service is provided to the end user through Layer 3 flows. The E3-2 operates at Layer 3, giving it visibility to monitor and control not just the flows but the specific service type that is being carried on the flows. For example, DNS traffic can be rate limited to prevent a DOS attack from flooding the PON with malicious DNS traffic. This provides unprecedented intelligence in an OLT that can be in harsh outdoor environments.

Additionally, usage data is gathered on each individual flow and conveyed to external IPDR collectors for billing. Toward the network, the E3-2 provides transport using Layer 2 switched VLANs, providing a simple means of configuring the transport network. Transport redundancy can be provided by configuring the E3-2 systems in a ring, and/or through Link Aggregation Groups. In this application, video service is typically provided using IPTV unicast as prioritized HSI data.

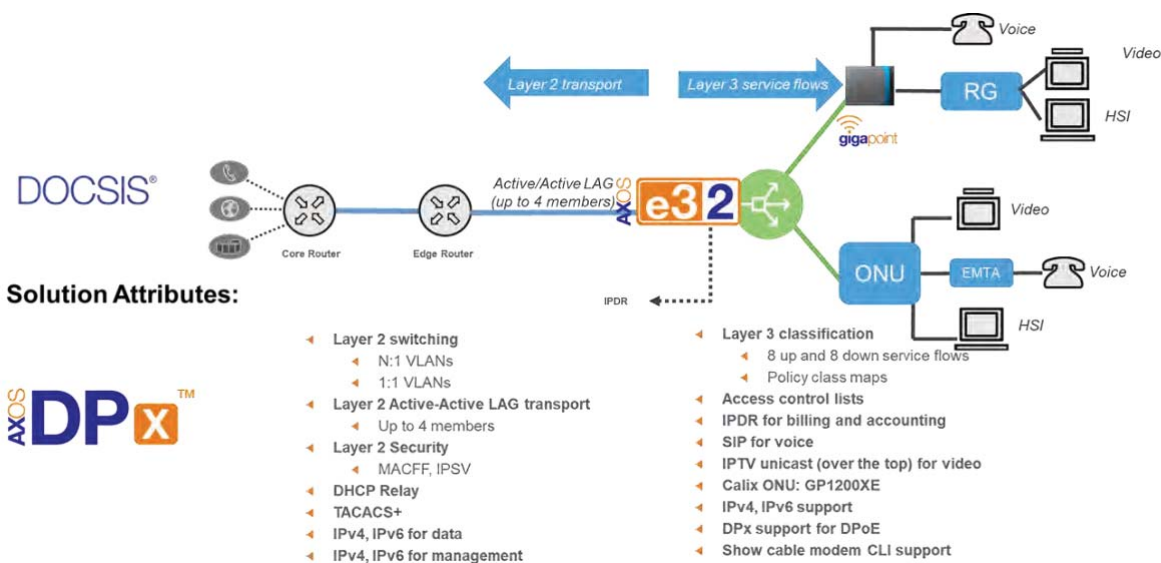

Figure 36. Layer 3 classification of 10G EPON residential services using a switched (VLAN) transport network

## Layer 3 classification of GPON or 10G EPON residential data service using a routed transport network

This application is typically associated with deployments in Cable MSOs. In this application, service is provided to the end user through Layer 3 flows. The E3-2 operates at Layer 3, giving it visibility to monitor and control not just the flows but the specific service type that is being carried on the flows. For example, DNS traffic can be rate limited to prevent a DOS attack from flooding the PON with malicious DNS traffic. This provides unprecedented intelligence in an OLT that can be in harsh outdoor environments.

Additionally, usage data is gathered on each individual flow and conveyed to external IPDR collectors for billing. Toward the network, the E3-2 can participate in a Layer 3 routed network. This allows the E3-2 to connect directly to Edge routers, eliminating the need for costly aggregation routers. The E3-2 supports standard Layer 3 routing protocols such as IS-IS, BGP, and OSPFv2 allowing support for both IPv4 and IPv6 networks. Transport redundancy can be provided by configuring the E3-2 systems in a ring with other routed equipment, and/or through Link Aggregation Groups. In this application, video service is provided using an RF overlay. The additional RF wavelength is split off at the residence using a micronode, while the ONT provides the data and voice service.

The following diagram illustrates a typical Layer 3 residential application in a routed network:

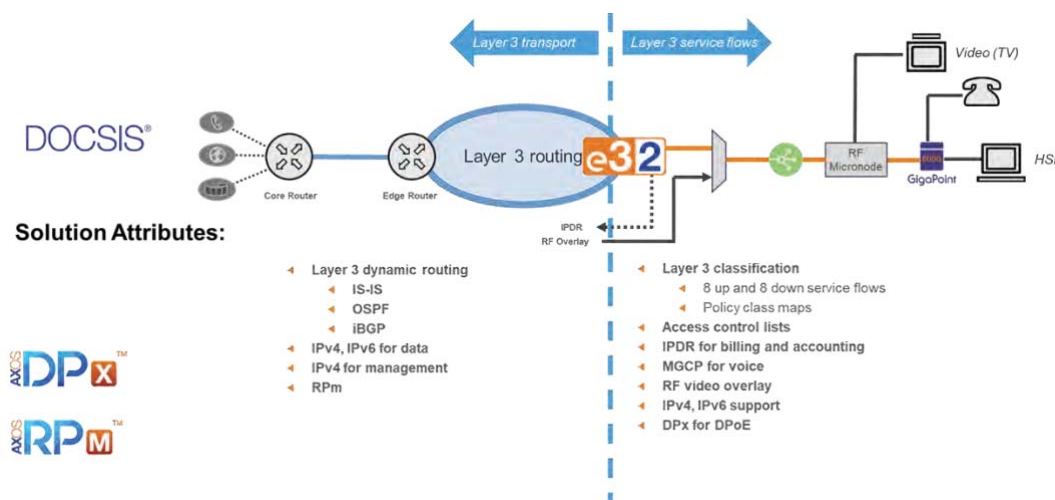

Figure 37. Typical Layer 3 Residential Service Application

Notes regarding this application:

- The E3-2 is responsible for terminating both the PON connectivity from each customer's ONT as well as applying all configurations to each customer based on the service they have purchased. This means applying policing and shaping to limit throughput to the speed tier the customer purchased, providing a layer 3 gateway IP, acting as a DHCP/DHCPv6 relay agent, applying access lists to filter traffic to protected internal subnets or sourced from restricted ports and prioritizing traffic towards the customer or towards the metro network.
- In this application, residential data services are provided as Layer 3 flows. The E3-2 supports up to 8 independent flows downstream, and 8 flows upstream. However, there is a VLAN tag that is used to carry services across the PON.
- If desired video service can be provided using an RF video overlay. A micronode is used at the residence to split the RF video from the PON wavelength. Support can also be provided for IPTV unicast using prioritized data on the PON.
- When using GPON, the Calix ONT 801G can be used as a demarcation point for a data service. If VoIP services are desired, then VoIP can be provided using either SIP or MGCP with an ONT 803G or other GigaFamily ONT. When using 10G EPON, the Calix ONT GP1200XE can be used to provide data services and (future) voice services
- The RG uses a DHCP discover/DHCPv6 solicit to get its IP address. All customer devices use NAT (for IPv4) or routing (IPv6 with Prefix Delegation) through the RG to get their IP address
- The E3-2 forwards traffic to a Layer 3 logical VLAN interface based on its incoming VLAN tag. The logical VLAN interface acts as a Layer 3 gateway and a DHCP Relay agent.
- The E3-2 uses Access Control Lists (ACLs) in both the upstream and downstream directions to (for example) restrict destination IP ranges, to restrict traffic to certain TCP/UDP ports, and to restrict the bandwidth of certain types of traffic (e.g., DNS traffic)
- The E3-2 gathers billing statistics per flow and transmits those to an IPDR Collector using the IPDR SAMIS Type 1 record format
- The E3-2 participates in the Layer 3 routed network. The E3-2 supports IS-IS, BGP, and OSPFv2 providing a flexible means of using the E3-2 in both IPv4 and IPv6 routed networks.

## New features in AXOS-R21.1

The following new capabilities are introduced for the E3-2 in AXOS-R21.1:

- **IPFIX enhancements.** IPFIX is a protocol for streaming OLT and ONT statistics to an external IPFIX data collector. To increase your ability to monitor the E3-2 system remotely, this release increases the number of OLT and ONT data statistics that can be reported via IPFIX. In addition, support is provided for UDP format collectors.
- **SNMP enhancements.** This release introduces numerous SNMP improvements expanding the ability to monitor system status and performance statistics.
- **GP1100X enhancements.** For GP1100X ONTs, support is added for H.248 and MGCP voice protocols. In addition, support is added for 802.1ag CFM.
- **Improved software image management for new hardware and spare cards.** This release introduces a new Factory Default Image that is shipped on all new hardware cards. This simplifies software version management and can be easily upgraded to any supported Calix AXOS software release.
- **AXOS always on upgrades.** This feature provides the ability to upgrade individual AXOS components without requiring a full system reboot. This results in an “always on” experience where individual AXOS components can be upgraded to correct a software issue.

### IPFix Enhancements

Calix AXOS OLTs support multiple mechanisms for gathering performance statistics from the OLT, including IPFIX. Using the IPFIX protocol, the OLT can stream statistics to an external IPFIX Collector at a user-specified interval (e.g., every 15 minutes). In this release the E3-2 provides the following IPFIX enhancements:

- IPFIX dataset enhancements
- Support for UDP format when transmitting to IPFIX collectors

The following is an overview of the IPFIX dataset enhancements in AXOS-R21.1:

- PON Utilization Stats
  - **New for AXOS-R21.1:** addition of PON port temperature (temperature), PON port transmitted power (tx-power), PON port optical voltage (tx-voltage), PON port admin status (admin-state), PON port interface transmit bias (tx-bias), and received unicast available bandwidth (rx-unicast-available bandwidth)
- PON Optical Stats from OLT and ONT:
  - **New for AXOS-R21.1:** addition of ONT side transmit optical level (tx-opt-level), ONT optical receive signal level (rx-opt-signal-level), range-length, and current version (curr-version)
- ONT Ethernet UNI Utilization Stats (received at OLT via OMCI)
  - **New for AXOS-R21.1:** configured speed on ONT-Eth interface (cfg-speed)
  - **New for AXOS-R21.1:** ONT Ethernet counters:
    - Upstream-unicast-packets

- Upstream-multicast-packets
  - Upstream-broadcast-packets
  - Downstream-unicast-packets
  - Downstream-multicast-packets
  - Downstream-broadcast-packets
- Ethernet interface counters for NNI and LAGs:
    - **New for AXOS-R21.1:** addition of hostname, shelf, slot, port, if-index, interface-ethernet-aid, mac, sample-time, drop-events, octets, pkts, broadcast-pkts, multicast-pkts, crc-align-error, undersize-pkts, oversize-pkts, pkts-64, pkts-65to127, pkts-128to255, pkts-256to511, pkts-512to1023, pkts-1024to1518, pkts-1519to2047, pkts-2048to4095, pkts-4096to9216, pkts-9217to16383, rx-pkts, rx=octets, rx-unicast-pkts, rx-multicast-pkts, rx-broadcast-pkts, rx-discards, rx-pause-frames, rx-errors, rs-unknown-protos, tx-pkts, tx-octets, tx-unicast-pkts, tx-multicast-pkts, tx-broadcast-pkts, tx-discards, tx-pause frames, tx-errors, align-errors, fcs-errors, jabbers, rx-utilization, tx-utilization, rx-pps, tx-pps, role

The E3-2 now supports UDP format in addition to TCP format when transmitting to IPFIX collectors. The UDP format is widely used by many third party IPFIX platforms, and support for UDP gives service providers the option to choose an IPFIX collector that best suits their network needs. The ability to select between TCP and UDP format for exporting to IPFIX collectors is selected within the **config-ipfix** CLI command.

## SNMP MIB Enhancements

In AXOS-R21.1, the E3-2 enhances its supported SNMP MIBs to provide additional capabilities to monitor the system via SNMP. New MIB files are provided for the following:

- Axos-System-MIB.mib: This MIB provides information about the AXOS system using the axosSystemModule table
- Axos-Card-MIB.mib: This MIB provides information about the system hardware modules including the admin state, the card serial number, part number and CLEI code. Additionally, the MIB includes information on the PON ports including the PON port status, transmitted and receive power, and PON port temperature.
- Axos-Ont-MIB.mib: This MIB provides information on the ONTs connected to the OLT system. This includes information on the admin and operational status of the ONT, the transmitted and received optical signal levels, and the ONT software version.

These enhancements are also supported on the other AXOS OLT system (E7-2 and E9-2), providing a common set of SNMP capabilities across all AXOS OLT systems.

## GP1100X Enhancements

AXOS-R21.1 includes support for the following GP1100X enhancements:

- Voice enhancements: in addition to SIP, support is now provided for H.248 and MGCP on the GP1100X
- 802.1ag CFM support: The GP1100X now includes support for 802.1ag CFM capabilities including CCMs, Loopback, and Link Trace messages

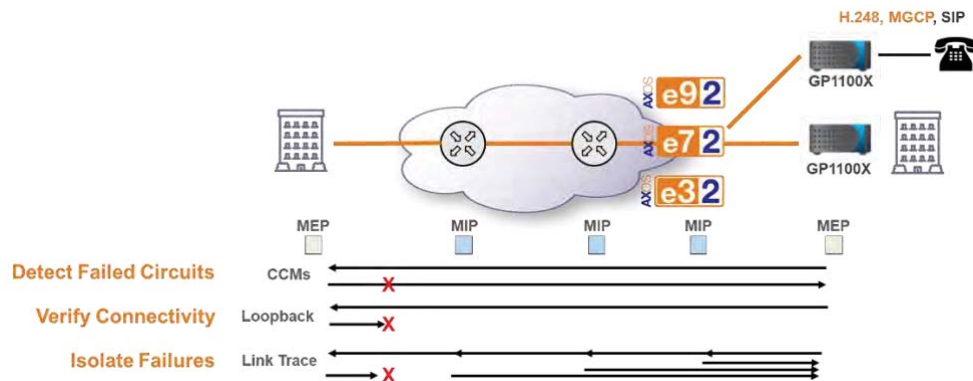

Figure 38. GP1100X enhancements: H.248, MGCP, 802.1ag

## Software Image Management Enhancements

When managing software versions in network deployments, a common challenge customers face is managing the software image in the network and the compatibility between different software versions. This can be compounded by the software version that ships from Calix on new line cards. In the past, Calix would ship a production software release on all new hardware, and periodically update the software image that was shipped. This could lead to the following problems:

- This software image may not be one that is standardized for deployment, leaving open the possibility that the default software is accidentally deployed onto a system.
- In addition, these cards can be stored in inventory for weeks or months, leading to the possibility of old or incompatible software when installed into a running network.

To address these challenges Calix has implemented a modification to the software image that ships with all new AXOS hardware including the E3-2. Beginning in AXOS-R21.1, all E3-2 systems will ship with a Factory Default Image. This image is compatible with all E3-2 software versions running in the field. This allows it to be quickly and easily upgraded automatically when inserted into a running system. In addition, there will no longer be a concern with having different production software versions on systems that are stored in inventory.

If a new system is turned up with cards that contain the Factory Default Image, the system will issue an alarm and prompt the user to upgrade to a production software release. Similarly, if the user logs into the CLI a banner will indicate that the image should be upgraded to a production software release.

## AXOS Always On Upgrades

As part of the commitment to reduce and eliminate maintenance windows, this release introduces support for AXOS Always On upgrades for AXOS components. One of the common challenges service providers face is the requirement to upgrade networking equipment in a maintenance window to address a software defect. To resolve these defects, a maintenance window, or windows, is scheduled that can span days or weeks based on the size of the deployment which extends the overall time period to address an issue. AXOS is a modular architecture that allows for individual components to be updated without requiring maintenance windows. Upon identifying a software issue, a specific module can be upgraded to resolve the identified issue. AXOS Release 21.1

includes the Always On upgrade feature that is supported on all the AXOS E-series systems: E9-2, E7-2, and E3-2.

AXOS Always On upgrades allows selective components or software modules to be upgraded without upgrading the entire AXOS image. This allows minor software changes to be applied onto a running card or the system without having to reload the card or the system. In order to qualify for an Always On upgrade, the impacted AXOS modules must meet the following criteria:

- The fixes must be for software fixes between cadence releases, not for regular cadence releases
- The impact of the change must be isolated to re-startable AXOS modules. In AXOS-R21.1, approximately 70% of all AXOS modules qualify for Always On upgrade

Note:

- For any release please refer to the Release Notes for information on whether the release qualifies as an Always On upgrade.
- An Always On release can only be applied to the corresponding cadence release (e.g., an AXOS-R21.1 Always On release cannot be applied to AXOS systems running AXOS-R21.2)
- The content of any Always On releases will be included in the next cadence release

The process for installing an Always On software maintenance release is the same as when doing a full system upgrade:

- Download the image for the system or line card
- Activate the image for the system or line card

In support of this new capability, the following CLI commands have been added or modified:

- **show live upgrades:** this command shows the installed or deactivated maintenance patch(es) in each image on each card. The following is an example screen output

```
CLX3001# show live-upgrades
live-upgrades 1/1
current
-----
PARTITION  PATCH  PACKAGE NAME  PACKAGE VERSION  RELEASE  DISTRO  STATE  INSTALL DATE
NUMBER                                     VERSION          VERSION
-----
imgx       1      log-mgr       3.4.2-r2         AXOS-R21.3.0.1  21.3.0.1  Active  Tue Sep 29 04:42:00 PDT 2020
-----

standby
-----

live-upgrades 1/2
current
-----
PARTITION  PATCH  PACKAGE NAME  PACKAGE VERSION  RELEASE  DISTRO  STATE  INSTALL DATE
NUMBER                                     VERSION          VERSION
-----
imgx       1      log-mgr       3.4.2-r2         AXOS-R21.3.0.1  21.3.0.1  Active  Tue Sep 29 04:42:00 PDT 2020
-----
```

- **show images:** this command includes the following information about the patch(es) in the following fields:
  - live-release-version - show the last patch's version
  - patches - show all patches' versions.

An example of the command output is shown below:

```
CLX3001# show images
images 1/1
summary
-----
PARTITION  RELEASE  MEDIA  STATE  NEXT  PATCHED  COMMITTED
-----
imgx       N/A       sda    Standby false  false    true
imgy       N/A       sda    Active  true   true     true
-----

active-image-status ok
detail
image imgx
full-release-version N/A
live-release-version N/A
image-type           FullRelease
patches              "yes(N/A, N/A)"
features             Signed-Optics-Enforcement-Disabled
distro               "MB-AXOS-21.1 2020.10.09 17:43:05"
schema              22.0.0
timestamp           "2021.02.09 17:43:05"
details              MBAXOS211-CI1-233
state                Standby
next                 false
image imgy
full-release-version N/A
live-release-version N/A
image-type           FullRelease
patches              yes(N/A)
features             "Signed-Optics-Enforcement-Disabled"
distro               "IB-AXOS-21.1 2020.11.09 14:12:40"
schema              23.0.0
timestamp           "2020.11.09 14:12:40"
details              IBAXOS211-CI1-483
state                Active
next                 true
active-image-status ok
```

- **show version patches:** this command displays all the patches installed on a given card. Below is the example output:

```
E9-2-Sys071# show version patches
version 1/1
patches "yes(AXOS-R21.1.0.1, AXOS-R21.1.0.2)"
version 1/2
patches "yes(AXOS-R21.1.0.1, AXOS-R21.1.0.2)"
version 2/1
patches "yes(AXOS-R21.1.0.1, AXOS-R21.1.0.2)"
```

- **show version live-release-version:** this command displays the last patch installed on a given card. Below is the example output:

```
E9-2-Sys071# show version live-release-version
version 1/1
live-release-version AXOS-R21.1.0.2
version 1/2
live-release-version AXOS-R21.1.0.2
version 2/1
live-release-version AXOS-R21.1.0.2
```

- **upgrade deactivate last|all:** this command deactivates the last patch or all patches on each card. Multiple deactivations are allowed prior to a reload. In addition, to remove the deactivated patch(es) user needs to perform a "reload all".

Below is the example output:

```
CLX3001# upgrade deactivate
status Attempting to deactivate. Check upgrade status for details
CLX3001# show upgrade status
upgrade 1/1
```



```

status
system-state      "System image deactivation completed; 'reload all' required to finish deactivation"
state             "Reload required to finish deactivation"
reason            OK
curl-error        "No error"
install-error     OK
remote-filename   file:///FLASH/logmgr.run
local-filename    /FLASH/tmp_install/4makeself/blackburn/LiveRelease_blackburn_IB-AXOS-
21.1_20200824232018_hdinh.run
image-type        LiveRelease
downloaded-bytes  9269849
download-speed-kbps 7241
download-percent-complete 100
download-finished-in-secs 10
verify-finished-in-secs 10
install-finished-in-secs 10
upgrade-finished-in-secs 30
upgrade-finished-timestamp "Fri Aug 28 11:43:14 2020"
install-media     sda
install-partition imgy
patch-to-deactivate 1
upgrade 1/2
status
state             "Reload required to finish deactivation"
reason            OK
curl-error        "No error"
install-error     OK
local-filename    /FLASH/tmp_install/4makeself/blackburn/LiveRelease_blackburn_IB-AXOS-
21.1_20200824232018_hdinh.run
image-type        LiveRelease
downloaded-bytes  9269849
download-speed-kbps 7241
download-percent-complete 100
download-finished-in-secs 10
verify-finished-in-secs 10
install-finished-in-secs 10
upgrade-finished-in-secs 30
upgrade-finished-timestamp "Fri Aug 28 11:43:14 2020"
install-media     sda
install-partition imgx
patch-to-deactivate 1

```

## Specifications

### Ethernet Switching Capacity

| Description                                   | Capacity   | Detail  |
|---|--|---|
| Switching Capacity                            | Wire speed full duplex forwarding across all ports   | Dedicated, non-blocking switch port to all PON and 10GE interfaces  |
| MAC Address Table Capacity                    | 32,000 MAC Addresses   |   |
| VLAN Support                                  | 4094 VLANs   | VLANs 1002, 1003, 1004, and 1005 are reserved for system use but can be changed to another range.   |
| Broadcast Video Channel Support               | 4000   | Maximum IGMP group size   |
| Number of Nodes Allowed in ERPS Ring          | 32 E-series cards per ring   | This number counts all E-Series cards located in the ring whether in a dual or single card E7 shelf, as well as all E3-2 systems. This number does not include devices or E7 subtended from the ring. |
| Number of Egress Priority Queues (10GE ports) | 8 per port   | Based on p-bit value with p-bit = 7 highest priority  |
| Queue Scheduling Algorithm                    | Strict priority with maximum and minimum guaranteed bandwidth per class  | Tail drop is used when dropping packets from queue  |
| Link Aggregation Groups                       | Up to 4  | Logical LAG interfaces per system   |
| Ports Allowed in 10GE LAG Groups              | Up to 4 x 10GE ports can be provisioned in a LAG group in Layer 2 application<br>Up to 1 x 10GE ports can be provisioned in a LAG group in Layer 3 application |   |

### PON Capacity

| Description                            | Capacity  | Detail  |
|--|---|---|
| MTU Packet Size (PON Services)         | 9600 bytes  | Requires an ONT that supports this capacity   |
| GPON Bandwidth                         | 2.488 Gbps down<br>1.244 Gbps up  |   |
| ONT Capacity                           | 64 per PON (software limit)<br>128 per PON (hardware limit)                     | Each PON has a non-blocking symmetric connection to the switch core                     |
| Bandwidth Shaping (ONT Ethernet ports) | 64 kbps to 1000 Mbps in 64 kbps increments                                      |   |
| Max. number of T-CONTs per PON         | 1024  | 8 T-CONTs per T-Series and P-Series GE ONT, 4 (+1 for OMCI) T-CONTs per P-Series GX ONT |
| Max. number of GEM Ports per PON       | 4096  |   |
| Max. number of T-CONTs per ONT         | 8   | P-bit values are mapped into eight CoS queues<br>P- and T-Series GE ONTs                |
| Max. number of GEM Ports per ONT       | 32  |   |
| Queue Scheduling Algorithm             | Strict priority and WFQ with maximum and minimum guaranteed bandwidth per class | Tail drop is used when dropping packets from queue                                      |

## Layer 3 Capacity

| Description   | Capacity  | Detail   |
|---|-----------|--|
| Routing   |           |  |
| FIB Size (switch)   |           |  |
| Maximum number of IPv4 network Routes (netmask 1-31)        | 32K       |  |
| Maximum number of IPv4 host routes (/32)                    | 64K       | There is a maximum of 64K IPv4 routes and hosts.   |
| Maximum number of IPv6 network Routes (netmask 1-127)       | 12K       | Maximum of 12K IPv6 hosts and routes   |
| Maximum number of IPv6 host routes (/128)                   |           |  |
| Host Table Size (switch)                                    |           |  |
| Maximum number of NDP Entries (next hop MAC in hardware)    | 4K        |  |
| Maximum number of ARP Entries (next hop MAC in hardware)    | 4K        |  |
| Host Table Size (switch)                                    |           |  |
| Maximum number of NDP Entries (next hop MAC in hardware)    | 4K        |  |
| Maximum number of ARP Entries (next hop MAC in hardware)    | 4K        |  |
| Host Table Size (software)                                  |           |  |
| Maximum number of next hop Entries (ARP or NDP)             | 4K        |  |
| RIB Size (software)   |           |  |
| Maximum number of ISIS Area                                 | 1         |  |
| Maximum number of BGP IPv4 Routes                           | 20000     |  |
| Maximum number of BGP IPv6 Routes                           | 20000     |  |
| Maximum number of ISIS Neighbors                            | 10        |  |
| Maximum number of OSPF Area                                 | 5         |  |
| Maximum number of OSPF IPv4 Routes                          | 5000      |  |
| Maximum number of OSPF Neighbors                            | 10        |  |
| Maximum number of BGP IPv4 Routes                           | 20000     |  |
| Maximum number of BGP IPv6 Routes                           | 20000     |  |
| Maximum number of BGP Peers                                 | 5         |  |
| Other   |           |  |
| Number of adjacent hosts per SD (VLAN on ONT Ethernet Port) | 8         | This is the maximum number of ARP/NDP entries which can exist on a per VLAN per ONT Ethernet port. |
| Number of SD  | 2048      | Each VLAN on an ONT Ethernet port uses one SD  |
| Configuration/Flow/QoS                                      |           |  |
| Maximum number of Policy-Maps Configured                    | 31        | This is how many unique policy-maps can be configured but not applied                              |
| Maximum number of Policy-Maps                               | 31        | This is how many unique policy-maps can be applied to interfaces                                   |
| Maximum number of Class-Maps Configured                     | unlimited |  |
| Maximum number of class-maps per policy-map                 | 1         |  |
| Maximum number of flows per class-map                       | 8/8       | This allows for 8 ingress and 8 egress flows in a class-map, or 8 bi-directional flows.            |
| Maximum number of rules per flow                            | 16        | There can be up to 16 match-rules per flow.  |
| Services  |           |  |
| Maximum number of DHCPv4 Relay Leases                       | 8000      |  |
| Maximum number of DHCPv6 Relay Leases                       | 8000      |  |
| Maximum number of Secondary IP address per interface        | 16        |  |
| Maximum number of Loopback Interfaces                       | 8         |  |
| Maximum number of DHCPv4 Server Leases                      | 1         | The DHCP server is only in support of devices locally connected to the craft port                  |

## Protocols and Standards Supported

| Standard      | Title  |
|---------------|--|
| IEEE 802.1ad  | Bridged VLANs - 802.1Q Amendment 4, Provider Bridges (QinQ or Stacked VLANs)   |
| IEEE 802.1D   | MAC Bridges  |
| IEEE 802.1p   | Priority   |
| IEEE 802.1Q   | Virtual Bridged Local Area Networks (VLAN)   |
| IEEE 802.1w   | Rapid Spanning Tree Protocol (RSTP)  |
| IEEE 802.3    | LAN/MAN Carrier sense multiple access with collision detection (CSMA/CD) access method and physical layer specifications, Ethernet |
| IEEE 802.3ad  | Link Aggregation   |
| IETF RFC 3046 | DHCP Relay Agent Information Option  |
| IETF RFC 2578 | Internet Group Management Protocol, Version 2 (IGMP v2)  |
| IETF RFC 4251 | Secure Shell (SSH) Protocol Architecture.  |

## XGS-PON ONT Support

The E3-2 with NG201 IMs operates with the Calix Giga Family series of 10G PON ONTs and is designed to operate with third-party ONTs. The following XGS-PON ONT models are currently supported:

| ONT MODEL                | ETHERNET PORTS  | VOICE PORTS | MEF CE 2.0 | RG   |
|--------------------------|-----------------|-------------|------------|------|
| Calix ONT GP1000X        | 1-100/1000/10G  | None        | No         | None |
| Calix ONT GPR3000X       | 1-100/1000/10G  | None        | Yes        | None |
| Calix ONT GH3200X        | 1-10GE          | 2           | No         | None |
| <b>Calix ONT GP1100X</b> | 1-100/1000/2500 | 1           | No         | None |

## DOCSIS Management Support using DPx

DPx enables cable operators to deliver, provision and ensure services over fiber using the Calix AXOS Intelligent Access Edge E-Series systems. DPx enables cable operators to continue to use DOCSIS operations support systems because DPx conforms to DOCSIS and DPoX standards. With DPx cable operators can deploy PON access networks for residential subscribers without changing operational procedures and systems.

DPx supports the following AXOS systems, ONUs, and services:

- AXOS-R21.1.0 System Software
- XGS-PON, GPON, and 10G EPON
- E3-2 remote OLT systems with 10G EPON, GPON, or XGS-PON\*
- E7-2 GPON-8 r2 or NGPON2-4 systems\*
- Provisioning of residential high-speed Internet services
- Provisioning of residential SIP service on GPON
- GPON ONUs
  - 812Gv2
  - 844G
  - 803G
  - 801G
  - 813Gv2
  - 823G-2
- XGS-PON ONUs
  - GP1000X
  - GP1100X
  - GH3200X
- EPON ONUs
  - GP1200XE

*\*Note: Mixed PON types in a single AXOS system are not supported in this release.*

*For additional information on DPx, please refer to the DPx Operations Guide.*

## E3-2 Ordering Information

When ordering the E3-2 system use the following approach:

- Choose an E3-2 equipment package. Note that the equipment package does not include a powering option.
- Choose a powering option and add the appropriate 100-level parts
- Add accessories if desired
- Add the desired pluggable transceiver modules
- Add the AXOS software licensing fees (details for this will be added in a future revision of this document)

The E3-2 system components may also be ordered as individual a la carte items. This includes availability of spare parts such as additional surge suppressors.

### CALIX E3-2 GPON PACKAGES

#### 000-00967 – E3-2 GPON Package – 8 Ports GPON with XFP WAN

This package provides 8 ports of GPON, and contains the following components:

| Part Number    | Description                                       | Quantity |
|----------------|---|----------|
| 100-04582..... | E3-2 Remote OLT – Container                       | 1        |
| 100-04583..... | E3-2 GP401 GPON-4 Interface Module (4 ports GPON) | 2        |
| 100-04598..... | XE401 10GE-4 WAN                                  | 1        |
| 100-04667..... | RCX3001 Control Module                            | 1        |
| 100-04668..... | RSX3001 Switch Module                             | 1        |
| 100-04672..... | E3-2 Integration Kit                              | 1        |

#### 000-01019 – E3-2 GPON Starter Package – 4 Ports GPON with XFP WAN

This package provides 4 ports of GPON, with the second interface module slot left unpopulated for future expansion. This package contains the following components:

| Part Number    | Description                                       | Quantity |
|----------------|---|----------|
| 100-04582..... | E3-2 Remote OLT – Container                       | 1        |
| 100-04583..... | E3-2 GP401 GPON-4 Interface Module (4 ports GPON) | 1        |
| 100-04598..... | XE401 10GE-4 WAN                                  | 1        |
| 100-04667..... | RCX3001 Control Module                            | 1        |
| 100-04668..... | RSX3001 Switch Module                             | 1        |
| 100-04672..... | E3-2 Integration Kit                              | 1        |

### 000-01152 – E3-2 GPON Package – 8 Ports GPON with SFP+ WAN

This package provides 8 ports of GPON, and contains the following components:

| Part Number    | Description                                       | Quantity |
|----------------|---|----------|
| 100-04582..... | E3-2 Remote OLT – Container                       | 1        |
| 100-04583..... | E3-2 GP401 GPON-4 Interface Module (4 ports GPON) | 2        |
| 100-05288..... | XE401S SFP+ 10GE-4 WAN                            | 1        |
| 100-04667..... | RCX3001 Control Module                            | 1        |
| 100-04668..... | RSX3001 Switch Module                             | 1        |
| 100-04672..... | E3-2 Integration Kit                              | 1        |

### 000-01153 – E3-2 GPON Starter Package – 4 Ports GPON with SFP+ WAN

This package provides 4 ports of GPON, with the second interface module slot left unpopulated for future expansion. This package contains the following components:

| Part Number    | Description                                       | Quantity |
|----------------|---|----------|
| 100-04582..... | E3-2 Remote OLT – Container                       | 1        |
| 100-04583..... | E3-2 GP401 GPON-4 Interface Module (4 ports GPON) | 1        |
| 100-05288..... | XE401S SFP+ 10GE-4 WAN                            | 1        |
| 100-04667..... | RCX3001 Control Module                            | 1        |
| 100-04668..... | RSX3001 Switch Module                             | 1        |
| 100-04672..... | E3-2 Integration Kit                              | 1        |

## CALIX E3-2 XGS-PON PACKAGES

### 000-01020 - E3-2 XGS-PON Starter Package - 2 Ports XGS-PON with XFP WAN

This package provides 2 ports of XGS-PON, and contains the following components:

| Part Number    | Description   | Quantity |
|----------------|---|----------|
| 100-04582..... | E3-2 Remote OLT – Container                                 | 1        |
| 100-04599..... | E3-2 NG201 10G PON interface module (2xXGS-PON/NGPON-2 XFP) | 1        |
| 100-04598..... | XE401 10GE-4 WAN  | 1        |
| 100-04667..... | RCX3001 Control Module                                      | 1        |
| 100-04668..... | RSX3001 Switch Module                                       | 1        |
| 100-04672..... | E3-2 Integration Kit  | 1        |

### 000-01155 - E3-2 XGS-PON Starter Package with SFP+ WAN (2 ports XGS-PON. 4x10GE SFP+ WAN)

This package provides 2 ports of XGS-PON, and contains the following components:

| Part Number    | Description   | Quantity |
|----------------|---|----------|
| 100-04582..... | E3-2 Remote OLT – Container                                 | 1        |
| 100-04599..... | E3-2 NG201 10G PON interface module (2xXGS-PON/NGPON-2 XFP) | 1        |
| 100-05288..... | XE401S SFP+ 10GE-4 WAN                                      | 1        |
| 100-04667..... | RCX3001 Control Module                                      | 1        |
| 100-04668..... | RSX3001 Switch Module                                       | 1        |
| 100-04672..... | E3-2 Integration Kit  | 1        |

### 000-01156 - E3-2 XGS-PON with SFP+ WAN (4 ports XGS-PON. 4x10GE SFP+ WAN)

This package provides 2 ports of XGS-PON, and contains the following components:

| Part Number    | Description   | Quantity |
|----------------|---|----------|
| 100-04582..... | E3-2 Remote OLT – Container                                 | 1        |
| 100-04599..... | E3-2 NG201 10G PON interface module (2xXGS-PON/NGPON-2 XFP) | 2        |
| 100-05288..... | XE401S SFP+ 10GE-4 WAN                                      | 1        |
| 100-04667..... | RCX3001 Control Module                                      | 1        |
| 100-04668..... | RSX3001 Switch Module                                       | 1        |
| 100-04672..... | E3-2 Integration Kit  | 1        |

#### 000-01157 - E3-2 XGS-PON with XFP WAN (4 ports XGS-PON, 4x10GE XFP WAN)

This package provides 2 ports of XGS-PON, and contains the following components:

| Part Number    | Description   | Quantity |
|----------------|---|----------|
| 100-04582..... | E3-2 Remote OLT – Container                                 | 1        |
| 100-04599..... | E3-2 NG201 10G PON interface module (2xXGS-PON/NGPON-2 XFP) | 2        |
| 100-04598..... | XE401 10GE-4 WAN  | 1        |
| 100-04667..... | RCX3001 Control Module                                      | 1        |
| 100-04668..... | RSX3001 Switch Module                                       | 1        |
| 100-04672..... | E3-2 Integration Kit  | 1        |

## CALIX E3-2 10G EPON PACKAGES

#### 000-01087 - E3-2 10G EPON Package - 4 Ports 10G EPON with XFP WAN

For 10G EPON customers who do not require MACsec encryption capabilities on the network uplinks, this package provides 4 ports of 10G EPON, and contains the following components:

| Part Number    | Description   | Quantity |
|----------------|---|----------|
| 100-04582..... | E3-2 Remote OLT – Container                                 | 1        |
| 100-04864..... | E3-2 XEP201 10G EPON Interface Module<br>(2 ports 10G EPON) | 2        |
| 100-04598..... | XE401 10GE-4 WAN  | 1        |
| 100-04667..... | RCX3001 Control Module                                      | 1        |
| 100-04865..... | RSX3001E 10G EPON Switch Module                             | 1        |
| 100-04672..... | E3-2 Integration Kit  | 1        |

#### 000-01112 - E3-2 10G EPON Starter Package - 2 Ports 10G EPON with SFP+ WAN

For 10G EPON customers who do not require MACsec encryption capabilities on the network uplinks, this package provides 2 ports of 10G EPON, and contains the following components:

| Part Number    | Description   | Quantity |
|----------------|---|----------|
| 100-04582..... | E3-2 Remote OLT – Container                                 | 1        |
| 100-04864..... | E3-2 XEP201 10G EPON Interface Module<br>(2 ports 10G EPON) | 1        |
| 100-04598..... | XE401 10GE-4 WAN  | 1        |
| 100-04667..... | RCX3001 Control Module                                      | 1        |
| 100-04865..... | RSX3001E 10G EPON Switch Module                             | 1        |
| 100-04672..... | E3-2 Integration Kit  | 1        |



### 000-01150 - E3-2 10G EPON with MACsec Package - 4 Ports 10G EPON with SFP+ WAN

For 10G EPON customers who require the additional MACsec encryption capabilities on the network uplinks, this package provides 4 ports of 10G EPON with additional hardware support for MACsec, and contains the following components:

| Part Number | Description   | Quantity |
|-------------|---|----------|
| 100-04582   | E3-2 Remote OLT – Container                                 | 1        |
| 100-04864   | E3-2 XEP201 10G EPON Interface Module<br>(2 ports 10G EPON) | 2        |
| 100-05288   | XE401S SFP+ 10GE-4 WAN                                      | 1        |
| 100-05287   | RCX3101 Control Module with Security Plate                  | 1        |
| 100-05289   | RSX3101E 10G EPON Switch Module with MACsec                 | 1        |
| 100-04672   | E3-2 Integration Kit  | 1        |

### CALIX E3-2 POWERING OPTIONS

After choosing an E3-2 equipment package, choose from one of the following powering options.

- Coax powering
- -48VDC powering
- AC powering
- Line powering (requires purchase of an external unit from Alpha)

The following table provides the part numbers for each powering option

| Powering Option                          | Part Number                   | Description   |
|--|-------------------------------|---|
| Coax Powering                            | 100-04586                     | E3-2 60VAC/90VAC Coaxial Input Power Supply Module  |
| -48VDC Powering                          | 100-04589                     | E3-2 Negative 48VDC Power/Alarm Cable 20'   |
| AC Powering                              | 100-04584                     | E3-2 RPS1000AC AC (Mains) Power Supply Module   |
|  | 100-04585                     | E3-2 AC Power/Alarm Cable   |
| Line Powering (thru external Alpha unit) | 0120057-001<br>(Alpha part #) | LPR12/48-150-IP68 +/-190Vdc to 12 or 48Vdc Line Powering Remote Downconverter Unit (must be ordered from Alpha) |

### CALIX E3-2 ACCESSORIES

The following E3-2 accessories are available as an option:

| Part Number | Description  |
|-------------|--|
| 100-04590   | E3-2 Pole/Wall Mount Kit                               |
| 100-04767   | Fiber Pigtail: 9 x SC/UPC, 9 x LC/UPC, 30ft, OSP rated |

Please note that the E3-2 Pole/Wall Mount Kit (100-04590) is not needed if the intent is to strand mount or pedestal mount the E3-2. For those cases, the included mounting clips are used.

### CALIX E3-2 Modules and Spare Parts

In addition to ordering as a package, the E3-2 system components may also be ordered as individual a la carte items. The following table lists the individual part numbers for the E3-2 replaceable modules and spare parts.

| Part Number | Description   |
|-------------|---|
| 100-04583   | E3-2 GP401 GPON-4 Interface Module (4 ports GPON)           |
| 100-04599   | E3-2 NG201 10G PON interface module (2xXGS-PON/NGPON-2 XFP) |
| 100-04864   | E3-2 XEP201 10G EPON Interface Module (2 ports 10G EPON)    |
| 100-04598   | XE401 10GE-4 WAN  |

|                        |  |
|------------------------|--|
| <b>100-04667</b> ..... | RCX3001 Control Module                               |
| <b>100-05287</b> ..... | RCX3101 Control Module with Security Plate           |
| <b>100-04668</b> ..... | RSX3001 Switch Module                                |
| <b>100-04865</b> ..... | RSX3001E 10G EPON Switch Module                      |
| <b>100-05289</b> ..... | RSX3101E 10G EPON Switch Module with MACsec          |
| <b>120-00368</b> ..... | E3-2 power shunt replacement part (quantity 10)      |
| <b>120-00369</b> ..... | E3-2 surge suppressor replacement part (quantity 10) |
| <b>120-00370</b> ..... | E3-2 fiber tray replacement part                     |
| <b>120-00387</b> ..... | E3-2 Desiccant Replacement Kit                       |

## CALIX OPTICAL PLUGGABLE MODULES

The E7-2 supports pluggable modules for all service and network interfaces. Refer to the Calix Optical Transceiver Modules Datasheet (#250-00191) for a complete list of modules and specifications including:

| Optic Type    | Description  |
|---------------|--|
| XFP           | 10GE optical Small Form-factor Pluggable (XFP) modules           |
| SFP+          | 10GE optical Enhanced Small Form-factor Pluggable (SFP+) modules |
| Direct Attach | Multi-rate copper Small Form-factor Pluggable (SFP/SFP+) cables  |

The following XGS-PON optics are available. These XGS-PON optics are encrypted and must be sourced from Calix.

| Optic Type | Description   |
|------------|---|
| 100-04692  | XGS-PON XFP, 10G/10G, 1577/1270nm, Single Fiber Transceiver, 20km, I-Temp                           |
| 100-05490  | XGS-PON SFP+, 10G/10G, Class N2, 1577/1270nm, Single Fiber Transceiver, 20km, I-Temp, OLT, E-Series |

The following AXOS GPON optics are available. These GPON optics are encrypted and must be sourced from Calix.

| Optic Type | Description  |
|------------|--|
| 100-05148  | GPON SFP OIM, Class B+, 20Km, 1490/1310nm Single Fiber Transceiver, I-Temp, AXOS |
| 100-05071  | GPON SFP OIM, Class C+, 60Km, 1490/1310nm Single Fiber Transceiver, I-Temp, AXOS |

### Calix Sourced Modules

High-speed optic module operational tolerances and performance vary significantly and can dramatically affect network operations. To maintain predictable performance and product reliability, Calix E-Series systems are supported with Calix GPON, XGS-PON, and NG-PON2 optical modules only (“Optical Modules”). Ethernet based SFP, CSFP, CDFP, XFP, SFP+, QSFP+, QSFP-DD, QSFP-28 pluggable transceivers (“Optical Transceivers”) and direct attach cables are available directly from Calix. Calix does not guarantee full compliance to product specifications for units using non-Calix modules and does not provide customer service support for optical network issues when non-Calix modules are used. Some third-party optics do not fully comply to the standard power and reach characteristics and in several cases have overheated and damaged the Calix equipment resulting in service outages. Calix Product Warranty shall not apply to any third-party Optical Modules, Optical Transceivers and direct attach cables, including counterfeit Calix branded products, used with Calix Products, nor shall the Product Warranty apply in the event that the Product’s defect or nonconformance is due to its use with hardware which is not purchased directly from Calix.

**HEADQUARTERS** 2777 Orchard Pkwy,  
San Jose, CA 95131  
Phone: 707-766-3000

**INFORMATION** Web: [www.calix.com](http://www.calix.com)

### **TECHNICAL SUPPORT**

Email: [techsupport@calix.com](mailto:techsupport@calix.com)  
Phone: 877-766-3500

### **ORDER MANAGEMENT**

Email: [order.management@calix.com](mailto:order.management@calix.com)  
Phone: 877-766-3500  
Fax: 707-283-3771