

City of
TOQUERVILLE

STANDARDS AND
SPECIFICATIONS

March 26, 2019

TABLE OF CONTENTS
CITY OF TOQUERVILLE STANDARD SPECIFICATIONS

SECTION 1 – General Conditions

1.1	Introduction	1-1
1.2	Definitions	1-1
1.3	Bonds and Insurance	1-6
1.4	Starting and Completing the Work	1-6
1.5	Before Construction Begins	1-6
1.6	Preconstruction Conference	1-7
1.7	Approved Documents Intent	1-7
1.8	Amending and Supplementing the Approved Drawings	1-8
1.9	Underground Facilities Shown or Indicated	1-8
1.10	Underground Facilities Not Shown or Indicated	1-9
1.11	Reference Points and Monuments	1-9
1.12	Contractor’s Responsibilities/Supervision/Superintendency	1-9
1.13	Safety and Protection	1-9
1.14	Site Emergencies	1-10
1.15	Authorized Variations in Work	1-11
1.16	Rejecting Defective Work	1-11
1.17	Warranty and Guarantee	1-11
1.18	Inspections and Observations	1-11
1.19	Contractor Employees	1-12
1.20	Historic, Archaeological or Paleontological Discoveries	1-12
1.21	Working Hours	1-12
1.22	Uncovering Work	1-12

1.23	City’s Representative May Stop the Work	1-12
1.24	Correction or Removal of Defective Work by Contractor	1-12
1.25	One Year Correction Period	1-12
1.26	Acceptance of Defective Work	1-13
1.27	Correction or Removal of Defective Work by Owner	1-13
1.28	Work Fully Completed	1-13
1.29	Final Inspection	1-13
1.30	Final Walkthrough	1-13
1.31	Final Acceptance	1-14
1.32	Suspension of Work	1-14

SECTION 2 – General Requirements

2.1	Introduction	2-1
2.2	Construction Drawings	2-1
	2.2.1 Something	2-1
	2.2.2 Curb and Gutter, Drainage, Sidewalks and Streets	2-2
	2.2.3 Sewer	2-3
	2.2.4 Culinary Water	2-3
	2.2.5 Power	2-4
	2.2.6 Detail Sheets	2-4
	2.2.7 Grading Plan	2-5
	2.2.8 General Utility Location Information	2-5
	2.2.9 Drawing Submittals	2-6
2.3	Inspection, Testing and Quality Control	2-6
	2.3.1 Requests for Inspection	2-6
	2.3.2 Construction Completion Inspection (Final Inspection)	2-7
	2.3.3 Guarantee of Work	2-7
	2.3.4 Quality Control Testing	2-8
	2.3.5 Test Reports	2-8
2.4	Drawings of Record	2-8
2.5	Barricades and Warning Signs – Work Area Protection	2-9

2.5.1	General Traffic Control Requirements	2-9
2.6	Cooperation with Utilities	2-10
2.7	Cooperation Between Contractors	2-11
2.8	Construction Stakes, Lines and Grades	2-11
2.9	Use of Explosives	2-12
2.9.1	Permits and Blast Plat	2-12
2.9.2	General Blasting Criteria	2-12
2.9.3	Logs	2-14
2.10	Protection and Restoration of Property and Landscape	2-14
2.11	Survey Monuments	2-15
2.12	Hazardous Materials Discoveries	2-15
2.13	Improvement Sequence	2-16
SECTION 3 – Design Standards		
3.1	Introduction	3-1
3.2	Street Design	3-2
3.2.1	Street Cross-Section Standards	3-2
3.2.2	Roadway Network Design	3-2
3.2.3	Improvement Requirements	3-6
3.2.4	Technical design	3-7
3.2.5	Pavement Structural design	3-16
3.2.6	Curb Side Mail Boxes	3-18
3.2.7	Signs and Pavement Markings	3-18
3.2.8	Underground Water	3-18
3.3	Off-site Improvement Soil Study Guidelines	3-18
3.4	Drainage and Flood Control Design	3-18
3.4.1	General Requirements	3-18
3.4.2	Design Criteria – Streets	3-20
3.4.3	Design Criteria – Storm Drains	3-21
3.4.4	Design Criteria – Culverts	3-22
3.4.5	Design Criteria – Bridges	3-22
3.4.6	Design Criteria – Channels	3-23
3.4.7	Design Criteria – Storage Facilities	3-23
3.4.8	Floodplains	3-25

3.4.9	Erosion Control	3-25
3.4.10	Irrigation Ditches	3-25
3.5	Sanitary Sewer Design and Standards	3-26
3.6	Culinary Water Design	3-26
3.6.1	Design Flow Pressure	3-26
3.6.2	Flow Design Criteria	3-26
3.6.3	Minimum Size and Depth	3-27
3.6.4	Valves and Hydrants	3-27
3.6.5	Pressure Reducing Valves	3-27
3.6.6	Fire Hydrant Spacing and Location	3-28
3.6.7	Fire Flow Requirements	3-29
3.6.8	Miscellaneous Water System Design Criteria	3-29
3.6.9	Network Hydraulic Analysis	3-31
3.7	Secondary Water or Wastewater Reuses Irrigation System	3-33
3.8	Other Utilities Systems Design	3-33
3.8.1	Responsibility	3-33
3.8.2	Street Lights	3-33
3.8.3	Burial of Lines	3-33
3.8.4	Layout	3-33
3.8.5	Front Lot Line Systems	3-33
3.8.6	Quality Control	3-33
3.9	Traffic Standards	3-34
3.9.1	Access Control	3-34
3.9.2	Traffic Impact Studies	3-34
3.10	Survey Monumentation Standards	3-36
3.10.1	General Requirements	3-36
3.10.2	Monuments	3-36
3.10.3	Types of Monuments	3-37

SECTION 4 – CONSTRUCTION STANDARDS

4.1	Introduction	4-1
4.2	Survey Requirements	4-1
4.3	Earthwork	4-1
4.3.1	Materials	4-1

4.3.2	Construction Methods	4-2
4.3.3	Quality Control	4-4
4.3.4	Special Requirements	4-5
4.4	Pipeline Construction	4-5
4.4.1	Materials	4-5
4.4.2	Construction Methods	4-16
4.4.3	Quality Control	4-29
4.5	Roadway Construction	4-31
4.5.1	Roadway Construction	4-31
4.5.2	Construction Staking	4-31
4.5.3	Grade Control Systems	4-32
4.5.4	Geotechnical Investigation	4-33
4.5.5	Roadway Subgrade	4-33
4.5.6	Subgrade – Class I and Class II	4-35
4.5.7	Untreated Roadbase – One Inch and Three-Quarter Inch	4-36
4.5.8	Prime Coat	4-38
4.5.9	Tack Coat	4-40
4.5.10	Dense-Graded Asphalt	4-40
4.5.11	Hydrated Lime for Asphalt Mixture	4-43
4.5.12	Aggregate	4-44
4.5.13	Storing, Mixing and Shipping of Plant Mix Bituminous Pavements	4-46
4.5.14	Asphalt Concrete Surge and Storage Silos	4-50
4.5.15	Shipping Asphalt Mixtures	4-51
4.5.16	Surface Preparation for Asphalt Overlays	4-51
4.5.17	Adjustment of Manhole and Utility Covers	4-51
4.5.18	Asphalt Paving Equipment	4-52
4.5.19	Rollers	4-53
4.5.20	Weather and Date Limitations	4-53
4.5.21	Spreading and Finishing	4-54
4.5.22	Rolling and Compacting	4-56
4.5.23	Open-graded Wearing Course	4-58
4.5.24	Acceptance Testing Requirements and Tolerances	4-61
4.6	Bituminous Seal Coat (Chip Seal)	4-66
4.6.1	Material Specifications	4-66
4.6.2	Aggregate Quality Control	4-67
4.6.3	Equipment	4-68
4.6.4	Bituminous Chip Seal Construction Methods	4-70
4.7	Asphalt Emulsion Seal Coat (Slurry Seal)	4-72
4.7.1	Material Specifications	4-73
4.7.2	Material Quality Control	4-77

4.7.3	Equipment	4-77
4.7.4	Asphalt Emulsion Slurry Construction Methods	4-78
4.8	Concrete Work	4-81
4.8.1	Materials	4-81
4.8.2	Construction Methods and Equipments	4-90
4.8.3	Quality Control	4-97
4.9	Restoration of Existing Surface Improvements	4-99
4.9.1	Introductions	4-99
4.9.2	Gravel Surfaces	4-100
4.9.3	Bituminous Surfaces	4-100
4.9.4	Concrete Surfaces	4-101

SECTION 5 – SIGNING AND PAVEMENT MARKINGS

5.1	Introduction	5-1
5.2	Signing Materials, Fabrication and Placement	5-1
5.2.1	Street Name Signs	5-1
5.2.2	Traffic Signs	5-1
5.2.3	Visibility	5-1
5.3	Pavement Marking	5-1
5.3.1	Line Types	5-2
5.3.2	Pavement Word and Symbol Markings	5-2
5.3.3	Traffic Paint	5-2
5.3.4	Temporary Markings	5-3
5.3.5	Raised Pavement Markers	5-3

SECTION 6 – STREET LIGHTING

6.1	Introduction	6-1
6.2	Streetlight Pole	6-1
6.3	Policy Number 5.6	6-1
	Street Light Installation Agreement	6-2

SECTION 7 – POWER SYSTEM

7.1	Introduction	7-1
7.2	Electrical Services	7-1
7.2.1	Power Connection	7-1

7.2.2	Electrical Service Agreement	7-1
7.2.3	Customer Service Facilities	7-1
7.3	Materials and Workmanship	7-2
7.4	Control of Ground Water	7-2
7.5	Excavation and Backfill	7-2
7.6	Concrete	7-3
7.7	Meters	7-3

SECTION I

GENERAL CONDITIONS

1.1 INTRODUCTION. This section contains the general conditions and instructions for development and other related construction of infrastructure improvements within the City of Toquerville. It sets forth the conditions by which this work will take place. It also sets forth the duties, responsibilities and obligations for the construction of improvements. These conditions apply to all development related work.

1.2 DEFINITIONS. Wherever used in these specifications the following terms have the meanings indicated which are applicable to both the singular and plural thereof.

1. **AASHTO:** The American Association of State Highway and Transportation Officials.
2. **ACCESS:** An intersection or driveway that connects with a public roadway to provide ingress and egress to a property or parcel of ground, whether public or private.
3. **ANSI:** The American National Standard Institute.
4. **APPROVED DOCUMENTS:** The approved drawings, standard specifications, standard drawings, and any other approved supplemental specifications and conditions.
5. **APPROVED DRAWINGS:** The graphic and pictorial portions of the approved documents approved by the City's Representative showing the design, location and dimensions of the work, and generally include, the plan, profiles, elevations, cross sections, details, schedules and diagrams, etc.
6. **ASTM:** The American Society for Testing Materials.
7. **AWWA:** The American Water Works Association.
8. **BACKFILL:** Any earth that has been excavated from a trench or other excavation and then replaced and compacted with existing or imported material.
9. **BENCH MARK:** A surveyor's mark made on a stationary object of previously determined position and elevation and used as a reference point for surveys or other applicable points.

10. **BONDS:** An instrument of security submitted by the owner and approved by the City to guarantee and/or warranty the required improvements.
11. **CITY:** The City of Toquerville, Utah, a governmental entity having authority to adopt and enforce ordinances.
12. **CITY ENGINEER:** The officially appointed Professional Engineer designated as the “City Engineer” to act in behalf of and for the City of Toquerville. May also refer to the City Engineer’s designated representative.
13. **CITY’S REPRESENTATIVE:** The person designated to act for and in behalf of the City of Toquerville.
14. **CITY SURVEYOR:** The officially designated Professional Surveyor who acts in capacity as the City Surveyor.
15. **CONTRACTOR:** The person, firm or corporation with whom the owner has entered into an agreement to construct the necessary work.
16. **CUSTOMER:** One for whom city related services are rendered.
17. **DECELERATION LANE:** An auxiliary lane, independent from through traffic lanes which is developed to allow turning vehicles to reduce their speed when approaching a driveway or intersection.
18. **DEFECTIVE WORK:** The work that is unsatisfactory, faulty or deficient, or does not conform to the approved documents, or does not meet the requirements of any inspection, reference standard, test or approval referred to in the approved documents, or has been damaged prior to the City Representative’s final inspection.
19. **DEVELOPER:** The authority, corporation, association or firm which undertakes the development or subdivision of land or properties and with whom the Contractor has entered into an agreement and for whom the work is to be provided.
20. **DEVELOPMENT:** The process of constructing a building or group of buildings for residential, commercial, industrial or other uses or the general changing of land or property into something other than its current or natural state or condition.
21. **DRAWING OF RECORD:** The drawing(s) or plan(s) which show the locations and dimensions of constructed facilities, based on actual measurements taken in the field, as governed by City’s policy and ordinances.
22. **EMBANKMENT:** Any raised area of compacted earth used to support a roadway, curb and gutter, sidewalk, trail, structure, parking lot, etc. Material used for

embankment shall be specified and tests shall be performed to determine the material's adequacy for the specific project.

23. **ENGINEER:** A Civil Engineer registered with the Utah State Department of Business Regulation and licensed to practice as a Professional Engineer in the State of Utah
24. **FILL:** Any material used to fill a depression, hole or any other anomaly in the ground. Material used for fill shall be specified and tests shall be performed to determine the material's adequacy for the specific project. Embankment is a type of fill.
25. **FINAL ACCEPTANCE:** Satisfaction on the part of the City's Representative that all work is fully complete and there are no other obligations to be fulfilled by the Contractor.
26. **FINAL INSPECTION:** An inspection of the work which is conducted by the City's Representative(s) and other necessary parties after said work is fully completed.
27. **FIRE CHIEF:** The officially appointed person designated as the City Fire Chief for the City of Toquerville or his designated representative.
28. **FLOOD PLAIN:** That area of a channel, river or other water course and the adjacent land areas which are inundated during abnormally high water (flooding) generally associated with a 100-year or 500-year flood event.
29. **FLOODWAY:** The area of the flood plain that is or must be reserved in order to pass the 100-year flood event in accordance with applicable regulations and which shall not be encroached upon by construction, fill or other development.
30. **GEOTECHNICAL ENGINEER:** That Professional Engineer registered with the Utah State Department of Business Regulation and licensed to practice as a Professional Engineer in the State of Utah specializing in geotechnical investigations which has been retained to investigate soil and other similar conditions and submit recommendations and/or reports concerning said conditions.
31. **HILLSIDE DEVELOPMENT STANDARDS:** The standards as noted in the City of Toquerville Hillside Ordinance used in all hillsides overlay zones.
32. **INSPECTION PUNCH LIST:** A written list of work discrepancies and deficiencies compiled by the City's Representatives and others during a final or other inspection.

33. **I.T.E.:** The Institute of Transportation Engineers.
34. **LAWS AND /OR REGULATIONS:** Any federal, state, county, city, or local jurisdiction's laws, rules, regulations, ordinances, codes, and orders.
35. **MAXIMUM DRY DENSITY:** The Maximum Dry Density shall be determined by ASTM Standard D-1557.
36. **MUTCD:** “The Manual of Uniform Traffic Control Devices”, latest edition and revisions as published by the U.S. Department of Transportation, Federal Highway Administration.
37. **OWNER:** The authority, corporation, association or firm with whom the Contractor has entered into an agreement and for whom the work is to be provided. This can refer to the Developer or the Owner of the property being developed.
38. **OWNER’S ENGINEER (OR THE ENGINEER):** The professional engineer or engineering firm (registered with the Utah State Department of Business Regulation) which has been retained by the Owner to produce plans, specifications, oversee work, etc. required by the Owner in the prosecution of the development of said Owner’s properties. (See engineer).
39. **OWNER'S REPRESENTATIVE:** The person, firm, or corporation designated to act for and in behalf of the owner.
40. **PLANS (DRAWINGS):** The graphic and pictorial portions of the documents approved by the City’s Representative showing the design, location and dimensions of the work, which generally include all details, schedules and diagrams required for construction of the project.
41. **POWER DEPARTMENT:** Shall refer to Utah Power and Light Company.
42. **PRESSURIZED IRRIGATION:** Refer to Washington County Water Conservancy District.
43. **PRIVATE IMPROVEMENTS:** The work or improvements which are undertaken by the Owner or Developer for the benefit of a select group of private individuals and are not maintained or repaired by the City and are not dedicated to the City for public use.
44. **PROJECT:** The total work to be provided under the approved documents.
45. **PUBLIC IMPROVEMENTS:** The work or improvements which are dedicated to

and maintained by the City for the benefit of the public-at-large.

46. **SEWER DISTRICT:** Refer to Ash Creek Special Sewer District.
47. **SHOP DRAWINGS:** All drawings, diagrams, illustrations, schedules and other data prepared by or for the Contractor to illustrate some portion of the work as well as all illustrations, brochures, standard schedules, performance charts, instructions, diagrams and other information prepared by suppliers and submitted by the Contractor to illustrate material or equipment required for some portion of the work.
48. **SOILS REPORT (GEOTECHNICAL REPORT):** That report produced by the Owner's Geotechnical Engineer and submitted to the City which describes the existing conditions, for the foundation soils of the lands being considered for development by the Owner. Said report also sets forth said Engineer's recommendations concerning the requirements of said soils for the intended use. (A soils report is the same as a geotechnical report).
49. **SPECIFICATIONS:** Those portions of the approved documents consisting of these Standard Specifications as well as other requirements for materials, equipment, construction systems, standards and workmanship as applied to the work and certain applicable administrative details.
50. **STANDARD SPECIFICATIONS:** The specifications contained in these documents.
51. **STREET NAME SIGNS:** Public and private signs indicating the street name, address coordinate, type of road, color designation or combination thereof.
52. **STRUCTURAL ENGINEER:** That Professional Engineer or engineering firm specializing in structural engineering and design which has been retained to design and engineer the structural elements required in the project under consideration.
53. **SUBCONTRACTOR:** An individual, supplier, firm or corporation having a contract with the Contractor or with any other subcontractor for the performance of any part of the work.
54. **SUBGRADE:** Subgrade shall refer to the native, prepared original soil or engineered fill under any roadway, fill, embankment, structure, etc.
55. **SUPPLEMENTARY CONDITIONS:** The part of the approved documents which amends or supplements the Standard Specifications.
56. **SUPPLIER:** A manufacturer, fabricator, distributor, material producer or vendor.
57. **SURVEYOR:** An individual registered with the Utah State Department of Business

Regulation and licensed to practice as a Professional Land Surveyor in the State of Utah.

58. **T.I.S.:** The Traffic Impact Study which may be required by the City and furnished by a Traffic Engineer for and in behalf of the Owner/Developer in accordance with all applicable standards and requirements of the City.
59. **TRAFFIC SIGNS:** All regulatory, warning, advisory, informational and other roadside traffic signs placed.
60. **UNDERGROUND FACILITIES:** All pipelines, conduits, ducts, cables, wires, manholes, vaults, tanks, tunnels or other such facilities or attachments, (as well as any encasement containing such facilities which have been installed underground to furnish any of the following services or materials; electricity, gases, steam, liquid petroleum products, telephone or other communication, cable television, sewage and drainage removal, traffic or other control systems or water.
61. **WATER DEPARTMENT:** Shall refer to City of Toquerville Water and its authorized City Representative.
62. **WORK:** The construction services and materials required to be furnished in accordance with the approved documents. Work is the result of performing services, furnishing labor and furnishing and incorporating materials and equipment into the construction.
63. **WORK COMPLETION or COMPLETION OF WORK:** Work and all obligations which have been fulfilled in accordance with the approved documents.
64. **XERISCAPE:** Desert-type landscaping requiring low-water demands as approved by the City.

1.3 BONDS AND INSURANCE. The Contractor shall be required to obtain all necessary bonds and to carry and provide proof of all necessary insurances needed to carry out the work.

1.4 STARTING and COMPLETING THE WORK. The Contractor shall start the work in a timely manner after receiving the approved plans. Work shall be performed in an expeditious manner so as not to unduly inconvenience the public. Work should be continuous without long periods of stoppage.

1.5 BEFORE CONSTRUCTION BEGINS. Before undertaking each part of the work, the Contractor shall carefully study and compare the approved plans and check and verify pertinent

figures shown thereon and all applicable field measurements. The Contractor shall promptly report to the Owner and the City's Representative any conflict, error or discrepancy which Contractor may discover and shall obtain a written interpretation or clarification from the Owner's Engineer and the City's Representative before proceeding with any work affected thereby.

Before any work at the site is started, Contractor shall deliver to City's Representative copies of all permits which Contractor is required to purchase/obtain and maintain, and Contractor's written plan to control quality of products and workmanship in the work.

1.6 PRECONSTRUCTION CONFERENCE. Before Contractor starts the work at the site, Contractor will attend a conference with Owner, Owners Engineer, City's Representative and others for the following purposes.

1. to discuss the work and the proposed schedule,
2. to discuss procedures for processing the project,
3. to designate the name of the individual who shall have the authority to act for the Contractor at all times while work is in progress, and
4. to establish a working understanding among the parties as to the work.

1.7 APPROVED DOCUMENTS INTENT. It is the intent of the approved plans and the standard specifications to describe a functionally complete project to be constructed in accordance with City Standards and good engineering practices. Any work, materials or equipment that may reasonably be inferred from as being required to produce the intended result will be supplied whether or not specifically called for. When words which have a well-known technical or trade meaning are used to describe work, materials or equipment, such words shall be interpreted in accordance with that meaning. Reference to standard specifications, manuals or codes of any technical society, organization or association, or to the laws or regulations of any governmental authority, whether such reference be specific or by implication, shall mean the latest standard specification, manual, code or laws or regulations in effect at the time of approval of the project, except as may be otherwise specifically stated.

If, during the performance of the work, Contractor finds a conflict, error or discrepancy in the approved plans or these standards, Contractor shall so report to the Owner and the City's Representative at once and before proceeding with the work affected thereby shall obtain an interpretation or clarification from Owner's Engineer and City's Representative.

1. In the event of any discrepancy between the scaled dimensions on any drawing and the written dimensions shown thereon, the written dimensions shall be taken as correct.
2. Any part of the work which is not mentioned in the specifications, but is shown on the drawings, shall be furnished and installed by Contractor as if fully described in the specifications.
3. Work and materials shall conform to the lines, grades, dimensions and material requirements, including tolerances, shown in the Standard Specifications and on the Approved Drawings. Although measurements, sampling and testing may be

considered evidence as to such conformity, City's Representative shall be the sole judge of whether the work or materials deviate from the approved documents and City Engineer's decision as to any allowable deviations there from shall be final. Deviation from approved documents, as may be required by the needs of construction, will be determined in all cases by the City Engineer or His Authorized Representative.

Performance by the Contractor shall be required only to the extent consistent with the approved documents and reasonably interpreted from the approved plans and standard specifications and any approved supplementary specifications as being necessary to produce the intended results. In case of an irreconcilable conflict between provisions the City Engineer's decision shall be final.

1.8 AMENDING AND SUPPLEMENTING the APPROVED DRAWINGS. The approved drawings may be amended on or after the effective date to provide for additions, deletions and revisions in the work thereof. All amendments, supplements, changes and directives require approval of the City Engineer or his Authorized Representative.

1.9 UNDERGROUND FACILITIES SHOWN OR INDICATED. The information and data shown or indicated in the approved plans with respect to existing underground facilities, at or contiguous to the site, is generally based on information and data furnished by others. Unless it is otherwise agreed to:

1. The City shall not be responsible for the accuracy or completeness of any such information or data;
2. Contractor and Owner shall have full responsibility for reviewing and checking all such information and data, with the one-call center (Blue Stakes location center) or other utility coordination service, prior to any excavation to locate all underground facilities shown or indicated in the approved plans; for coordination of the work with the owners of such underground facilities during construction, and for the safety and protection thereof and repairing any damage thereto resulting from the work.

1.10 UNDERGROUND FACILITIES NOT SHOWN OR INDICATED. If an underground facility is uncovered or revealed at or contiguous to the site which was not shown or indicated in the plans the Contractor shall promptly, and before performing any work affected thereby (except in an emergency), identify the owner of such underground facility and give appropriate notice thereof to that owner and to City's Representative. The Owner's Engineer will promptly review the underground facility to determine the extent to which the plans should be modified to reflect and document the consequences of the existence of the underground facility. The plans will be amended or supplemented to the extent necessary. During such time, Contractor shall be responsible for the safety and protection of such underground facility.

1.11 REFERENCE POINTS AND MONUMENTS. Owner's Representative shall establish land survey reference points for construction to enable Contractor to proceed with the work. Contractor shall be responsible for laying out the work, shall protect and preserve the established reference points and shall make no changes or relocations without the prior approval of City's Representative. Contractor shall report to City's and Owner's Representative whenever any reference point is lost or destroyed or requires relocation because of necessary changes in grades or locations, and shall be responsible for the accurate replacement or relocation of such reference points by professionally qualified personnel.

Contractor shall not disturb any survey monuments found within the construction area until approved by the City's Representative. No survey monument shall be disturbed or moved until City's Representative has been notified and Owner's Representative has referenced the survey monument for resetting.

1.12 CONTRACTOR'S RESPONSIBILITIES - SUPERVISION AND SUPERINTENDENCY. Contractor shall supervise and direct the work competently and efficiently, devoting such attention thereto and applying such skills and expertise as necessary to perform and complete the work in accordance with the approved plans and the standard specifications. Contractor shall be solely responsible for the means, methods, techniques, sequences and procedures of construction. Contractor shall be responsible to see that the finished work complies accurately with the approved documents.

Contractor shall keep on the site at all times during the works progress a competent superintendent. The superintendent will be Contractor's representative at the site and shall have authority to act on behalf of Contractor. All communications given to the superintendent shall be as binding as if given to Contractor.

1.13 SAFETY AND PROTECTION. Contractor shall be responsible for initiating, maintaining and supervising all safety precautions and programs in connection with the work. Contractor shall take all necessary precautions for the safety of, and shall provide the necessary protection to prevent damage, injury or loss to:

1. all employees on the work and other persons and organizations who may be affected thereby;
2. all the work and materials and equipment to be incorporated therein, whether in

- storage on or off the site; and
3. other property at the site or adjacent thereto, including trees, shrubs, lawns, walks, pavements, roadways, structures, utilities and underground facilities not designated for removal, relocation or replacement in the course of construction.

Contractor shall comply with all applicable laws and regulation of any public body having jurisdiction for the safety of persons or property, or to protect them from damage, injury or loss; and shall erect and maintain all necessary safeguards for such safety and protection. Contractor shall notify owners of adjacent property and of underground facilities and utility owners when prosecution of the work may affect them, and shall cooperate with them in the protection, removal, relocation and replacement of their property. All damage, injury or loss to any property caused, directly or indirectly, in whole or in part, by the Contractor, any subcontractor, supplier or any other person or organization directly or indirectly employed by any of them to perform or furnish any of the work or anyone for whose acts any of them may be liable, shall be remedied by Contractor. Contractor's duties and responsibilities for the safety and protection of the work shall continue until such time as all of the work is completed and City's Representative has issued a notice to Contractor that the work is acceptable.

The City, its officers, employees and agents, and the City's Representative shall not be answerable or accountable in any manner for any damage or loss that may happen to the work or any part thereof; for any material or equipment used in performing the work; for injury to property or person or persons; for damage to property; or for damage to adjoining property from any cause whatsoever during the progress of the work or at any time before final acceptance.

Contractor shall have the charge and care of the work and shall bear the risk of injury or damage to any part thereof by any acts of God or the elements or from any other cause. Contractor shall rebuild, repair and restore, and make good all injuries or damages to any portion of the work occasioned by any of the above causes before the date of final acceptance and shall bear the expense thereof.

City may make or cause to be made such temporary repairs as are necessary to restore service to any damaged facility. The cost of such repairs shall be borne by the Contractor.

The Contractor acknowledges that he is familiar with and will conform with the latest general safety orders of the State Industrial Commission, as contained in the Utah Occupational Safety and Health Act. The presence on site of an inspector or other person representing the City shall not in any way be construed to limit the Contractor's full responsibility for safety of all persons on the premises.

1.14 SITE EMERGENCIES. In emergencies affecting the safety or protection of persons or the work or property at the site or adjacent thereto, Contractor, without special instruction or authorization from City's Representative is obligated to act to prevent threatened damage, injury or loss. Contractor shall give City's Representative prompt written notice if Contractor believes that any significant changes in the work or variations from the approved documents have been caused thereby.

1.15 AUTHORIZED VARIATIONS IN WORK. Variations in the work shall be authorized by the Owner's Engineer and approved by the City's Representative.

1.16 REJECTING DEFECTIVE WORK. City's Representative and the Owner and his Engineer will have authority to disapprove or reject work which they believe to be defective, and will also have authority to require special inspection or testing of the work whether or not the work is fabricated, installed or completed.

1.17 WARRANTY AND GUARANTEE. Contractor warrants and guarantees to City that all work will be in accordance with the approved documents and will not be defective. All defective work, whether or not in place, may be rejected, corrected or accepted with conditions at the sole discretion of the City.

1.18 INSPECTIONS AND OBSERVATIONS. Contractor shall give City's Representative at least twenty-four hours notice of readiness of the work for all required inspections, or approvals. Inspections and tests made at any point other than the point of incorporation in the work shall not be considered as a guarantee of acceptance. Any retesting of work or materials rejected shall be at Contractor's expense.

City's Representative(s), Owner's Engineer, testing agencies and governmental agencies with jurisdictional interests will have access to the work at reasonable times for their observation, inspecting and testing. Contractor shall provide proper and safe conditions for such access.

If laws or regulations of any public body having jurisdiction require any work (or part thereof) to specifically be inspected, tested or approved by other than City's Representative and the Owner's Engineer, Contractor shall assume full responsibility therefore, and furnish City's Representative the required certificates of inspection, testing or approval.

Contractor shall be responsible for all costs in connection with any inspection or testing required in connection with City's acceptance of materials supplied, or equipment proposed to be incorporated in the work, or of materials or equipment submitted for approval prior to Contractor's purchase thereof for incorporation in the work.

All work and materials, and the manufacture and preparation of such materials from the beginning of the work until work completion, shall be subject to acceptance or rejection by the City's Representative.

Any work or materials not in accordance with the approved documents that may be discovered before work completion shall be corrected upon notification by City's Representative. Inspection by City's Representative shall not relieve Contractor from responsibility to furnish material and workmanship in accordance with the approved documents. Failure on the part of City's Representative to discover, condemn or reject materials or work shall not be construed to imply acceptance of the same should their noncompliance become evident before work completion. It is expressly understood that nothing in this paragraph waives any of the City's rights under the guarantee provision of these specifications.

1.19 CONTRACTOR EMPLOYEES. Only competent employees of the Contractor, or subcontractor, shall be employed on the work project. Any person employed by Contractor, the subcontractor themselves, or subcontractor employees, who is found by City's Representative to be incompetent, intemperate, troublesome, disorderly or otherwise objectionable, or who fails or refuses to perform work properly and acceptably, shall be immediately removed from the work project by the Contractor and not be re-employed on the work project.

1.20 HISTORIC, ARCHAEOLOGICAL OR PALEONTOLOGICAL DISCOVERIES. If a suspected regulatory historic, archeological or pale ontological item, feature, or site is encountered, construction operations shall be immediately stopped in the vicinity of the discovery and the Owner and proper state and/or federal agencies shall be notified of the nature and exact location of the findings. The Contractor shall not damage the discovered objects.

The Owner shall keep the City's Representative informed as to the status of any restrictions placed upon the project and when such restrictions are removed.

1.21 WORKING HOURS. Construction activities on the contract work site shall comply with any applicable local noise and other ordinances. Unless otherwise directed or upon approval of different hours by City's Representative, working hours at the work site shall be limited to between 7:00 A.M. and 7:00 P.M. local time. Work shall not proceed on Saturday, Sunday, or on any legal holidays without prior approval from the City's Representative.

1.22 UNCOVERING WORK. If any work is covered or buried contrary to the request of City's Representative, it must, if requested, be uncovered for observation, inspection or testing as may be required to verify compliance at the Contractor's expense.

1.23 CITY'S REPRESENTATIVE MAY STOP THE WORK. If the work is defective, or Contractor fails to supply sufficient skilled workers or suitable materials or equipment, or fails to furnish or perform the work in such a way that the completed work will not conform to the approved documents, City's Representative may order Contractor to stop the work, or any portion thereof, until the cause for such an order has been eliminated.

1.24 CORRECTION OR REMOVAL OF DEFECTIVE WORK BY CONTRACTOR. If required by the City's Representative, the Contractor shall promptly, as directed, either correct all defective work, whether or not fabricated, installed or completed, or if the work has been rejected by the City's Representative, remove it from the site and replace it with non-defective work. The Contractor shall bear all direct, indirect and consequential costs of such correction or removal (including but not limited to fees and charges of the City, engineers, architects, attorneys and other professionals) made necessary thereby.

1.25 ONE YEAR CORRECTION PERIOD. If within the one year guarantee period, or such longer period of time as may be prescribed by laws or regulations, or by the terms of any applicable special guarantee required, or by any specific provision of the approved documents, any work is found to be, defective regardless of cause, the Owner shall promptly cause the Contractor, without

cost to the City, either correct such defective work, or, if it has been rejected by the City, remove it from the site and replace it with non-defective work. If the Contractor fails within thirty days to promptly comply with the terms of such instructions, or in an emergency where notice and delay would cause serious risk of loss or damage, the City may have the defective work corrected or the rejected work removed and replaced, and the Owner shall be liable for all direct, indirect and consequential costs of such removal and replacement.

The one year correction period shall similarly apply to all rework done by the Contractor.

1.26 ACCEPTANCE OF DEFECTIVE WORK. If, instead of requiring correction or removal and replacement of defective work, and City prefers to accept it, City may do so. Owner shall bear all direct, indirect and consequential costs attributable to City's Representative evaluation of and determination to accept such defective work.

1.27 CORRECTION OR REMOVAL OF DEFECTIVE WORK BY OWNER. If Owner fails within a reasonable time after written notice of City's Representative to proceed to correct defective work or to remove and replace rejected work as required by City's Representative, or if Contractor fails to perform the work in accordance with the approved documents, City may, after seven days' written notice to Owner, correct and remedy any such deficiency. All direct, indirect and consequential costs of City in exercising such rights and remedies will be charged to the Owner. Such direct, indirect and consequential costs will include but not be limited to fees and charges of engineers, architects, attorneys and other professionals, all court costs and all costs of repair and replacement of work of others destroyed or damaged by correction, removal or replacement of defective work.

1.28 WORK FULLY COMPLETED. When Owner considers the work (or portion thereof) ready for its intended use, Contractor shall certify in writing to City's Representative that the work (or portion thereof) has been completed in accordance with the approved documents. If fully completed, City's Representative shall within a reasonable time, schedule a **final inspection** preparatory to writing the final inspection punch list and in accordance with these standard specifications and City policies.

1.29 FINAL INSPECTION. After all construction work is complete, the Developer shall request a "Construction Completion Inspection" (final inspection). Upon receipt of the request the City shall schedule this inspection with the appropriate parties. Any faulty or defective work shall be detailed in the City's inspection report. All faulty and defective work shall be corrected within 30 days from the date of the City's inspection report. If, after thirty days, the faulty or defective work has not been completed, another "final inspection" may be conducted by the City to determine if additional corrective work is required. The development will not be released and the guarantee period will not commence until all faulty work has been corrected.

1.30 FINAL WALKTHROUGH. Prior to the end of the guarantee period, a final walk through will be conducted. The Owner and the Contractor should contact the City's Representative to schedule the walk through. All work found to be defective shall be corrected immediately. This is preparatory to final acceptance by the City.

1.31 FINAL ACCEPTANCE. If, on the basis of Owner's and Contractor's request that work be given final acceptance and City's Representative is satisfied that the work has been satisfactorily completed and after a final or one-year walk through has taken place, the City's Representative will give written notice to Owner that the work is acceptable and the guarantee period will end. Otherwise, City's Representative will indicate in writing to Owner the reasons for refusing to recommend final acceptance, in which case Owner shall make the necessary corrections and resubmit request for final acceptance approval.

1.32 SUSPENSION OF WORK. The City's Representative shall have the authority to suspend the work wholly or in part for such period as City's Representative may deem necessary due to unsuitable weather or to such other conditions City's Representative considers unfavorable for suitable prosecution of the work. The Contractor shall immediately comply with the City's Representative order to suspend the work wholly or in part. The suspended work shall be resumed when the conditions are favorable and methods are corrected as approved in by the City's Representative.

In the event the suspension of work is ordered for any reason, the Contractor, at Contractor's expense shall do work necessary to provide a safe and secure site. If pedestrian or vehicular access is required, a smooth and unobstructed passageway shall be provided through the construction site for use by the public. In the event the Contractor fails to perform this work, the City may perform such work and the cost thereof will be billed to the Contractor or Owner.

SECTION 2

GENERAL REQUIREMENTS

2.1 INTRODUCTION. This section defines the general requirements for development work and other related construction of infrastructure improvements within the City of Toquerville. It covers such items as drawing requirements, inspections, traffic control, and cooperation with others, use of explosives and other miscellaneous requirements.

The improvements shall include all public and private infrastructures, including, but not limited to streets, water, sewer, traffic and drainage.

- Required improvements shall extend from the nearest acceptable point of existing improvements.
- Layouts must provide for future extension to adjacent properties and shall be compatible with appropriate City of Toquerville master plans.
- All underground improvements shall be installed to the boundary lines of the development and in some cases extended beyond boundary to assure system reliability.
- Required geotechnical investigation recommendations shall be followed.

2.2 CONSTRUCTION DRAWINGS. Complete and detailed construction plans, drawings of improvements, and all necessary reports shall be submitted to the City for review and acceptance. All plans, drawings and reports submitted shall be stamped and signed by a professional Civil Engineer licensed in the State of Utah.

The instructions contained herein are for the purpose of standardizing the preparation of drawings and to obtain uniformity in appearance, clarity, size and style. The plans and drawings shall meet the standards hereinafter outlined.

All drawings and/or prints shall be clear and legible and conform to standard engineering and professional drafting practice.

The standard drawing size shall be twenty-four by thirty-six inches.

Note: Construction work shall not begin until the appropriate construction plans and reports have been reviewed for compliance with City requirements and released for construction by the City Engineer or his appropriate City Representative(s).

2.2.1 GENERAL. The following shall be included on the drawings. The City may require additional information as it deems necessary:

- A. North arrow.
- B. Scale - Standard engineering scales shall be used. Uncommon scales generated by CAD systems shall not be used. Graphic scales should be used where drawings may be reduced.

- C. Stationing and elevations for profiles - Profiles should be drawn directly below plan view when possible. Bench marks and elevations must be referenced to latest revision of USGS datum or other datum as may be approved.
- D. Title block, located on the right side of the sheet to include:
 - 1. Project title;
 - 2. Type of project;
 - 3. Professional Engineers stamp (licensed in the State of Utah) and signature.
 - 4. Name, address and phone number of firm preparing drawings.
 - 5. Date, drawing number, drawn by, checked by, and other appropriate information.
 - 6. Name, address and telephone number of Owner/Developer and contact person.
- E. Revision block, located in or above title block containing the revision number, description, date, and reviser's name.
- F. Drawings shall have a heavy border outlining the entire sheet situated approximately ½ inch from the top and sides and 1 inch from the bottom.
- G. Additional information as required by the Joint Utility Committee (JUC) shall also be required on the drawings. (See the JUC for requirements).

2.2.2 CURB AND GUTTER, DRAINAGE, SIDEWALKS AND STREETS. The drawings for curb and gutter, drainage, sidewalks and streets shall contain:

- A. Plan view showing all necessary information to completely detail the work to be constructed including, but not limited to, all existing improvements, right-of-way lines, easement boundaries, roadway centerline, curb and gutter location, sidewalks, cross drains, cut and fill slopes, drainage pipes, etc. for each street.
- B. Top back of curb and street centerline elevations at one hundred (100) foot intervals or at every lot line and at all PC's, mid-points and PT's. At all street intersections, elevations shall be shown at the half delta points (minimum).

- C. Standard engineering stationing and all curve data.
- D. Plan and profile and details of drainage system showing flow directions, pipe grades, inlets, cleanouts, invert elevations, and types of pipe, etc.
- E. Bench mark locations and elevations (latest revisions of USGS datum must be used).
- F. Typical street cross section from right-of-way line to right-of-way line, showing type of curb, sidewalk and pavement section.
- G. Gradient center line of roads, top, back of curbs (if different from centerline), or edge of pavement (if different from centerline and no curb exists), and flow-lines of drainage pipes and channels. Profiles shall be shown at all intersections to assure that street grades transition smoothly. Transition grades shall not be left to be worked out in the field!
- H. Location of existing and proposed permanent survey monuments.
- I. Profiles shall show existing ground profile at the centerline and each right of way line.
- J. When matching into existing improvements, profiles shall be extended for a minimum of two hundred and fifty (250) feet to assure that road transitions are smooth. When matching into existing improvements across the street, cross-sections shall be shown indicating how the new portion will match.

2.2.3 SEWER. Sewer drawings shall show:

- A. Plan and profile sheets showing location, size, and grade of main lines, sub mains, and service laterals (existing and proposed).
- B. Manhole size, type, station (location) and elevation at top of manhole and flow-line (in and out).
- C. Type of pipe (in accordance with City's standards).
- D. Bench mark locations and elevations (latest revision of U.S.G.S. datum shall be used).
- E. Trench details showing bedding backfill, compaction and shoring requirements.

2.2.4 CULINARY WATER. Culinary water drawings shall show:

- A. Size, location and type of all existing and proposed water mains, valves and hydrants, service laterals and all necessary appurtenances.
- B. Type of pipe (in accordance with City standards).
- C. Profile drawings showing high and low elevation with respect to grade.
- D. Minimum cover shown (thirty-six inches to top of pipe).
- E. Typical and special trench details showing bedding, backfill, compaction and shoring requirements.
- F. Backflow protections devices.

2.2.5 POWER. Power drawings shall show:

- A. Point of interconnect (to be determined by City's Representative before plans are prepared and submitted).
- B. Location of existing and proposed transformers, service boxes, street lights, etc.
- C. Primary, secondary and service lines and phasing details.
- D. Topography and proposed grading unless shown on grading plans.
- E. Sizes, capacities and characteristics of all components (e.g., wire, transformers, etc.)
- F. Approval block for respective utility.

2.2.6 DETAIL SHEETS. Each set of plans shall be accompanied by a separate sheet of details (unless already shown on standard drawings) for structures which will be constructed. Detail sheets shall include the following information:

- A. Drawing size: twenty-four by thirty-six inches.
- B. Scale of each detail.
- C. Title block on the right side of the sheet (same format on all sheets).
- D. Information required in section 2.2.1.D., E. and F.
- E. All details must be properly dimensioned and labeled.

- F. All details shall conform to the details shown in the standard drawing section of these standards. All details not in conformance with the standard details shall require individual approval.

2.2.7 GRADING PLAN. All development projects and projects requiring installation of public and private improvements are required to obtain a grading permit. A grading plan shall be submitted showing, at a minimum, the details outlined in Appendix Chapter 33 of the Uniform Building Code (UBC). The grading plan should be included with the Construction Drawings when submitted to the City Representative for review.

A Soils Engineering Report and an Engineering Geology Report addressing the adequacy for the intended use of the proposed development shall be submitted with the grading plan.

When Construction Drawings, including the grading plan, are approved by the City's Representative, a grading permit will be issued upon payment of the required grading plan review and permit fees in accordance with the fee schedule included in Appendix Chapter 33 of the UBC.

2.2.8 GENERAL UTILITY LOCATION INFORMATION. The following information is provided as a general guide in laying out utilities during the preparation of construction drawings. This information is to be used as a guide and may be changed by the City as required. For more precise information contact the Joint Utility Committee (JUC) and the City Engineering Division.

- A. A proximity detail and street locations will be required for all utility drawings.
- B. The sewer, drainage and power layouts should be the first utilities designed.
- C. For joint trench details, placement and layout of utilities and burial depths see standard drawings.
- D. A joint trench for phone, cable and power shall be located on the north and west side of the roadway behind the sidewalk (whenever possible) or opposite gas. In planned developments without sidewalks, joint utility trenches shall be thirty-six inches from back of curb.
- E. Water and gas lines shall be located on the south and east side of the roadway with the gas line located behind sidewalk and water line located five feet into roadway measured from the lip of curb (whenever possible) or opposite power. In planned developments, gas lines shall be located at lip of curb. The water location would remain the same.
- F. Sewer lines will generally be located fifteen (15) feet from the curb and gutter on the same side of the road as the power system.

G. Storm drain lines will be placed at the inside lip of curb and gutter as per standard drawing detail.

H. The cable and phone boxes will be located on the right and left side of power transformers and secondary boxes. The cable shall be on the left and phone on the right when looking from the street at the lot to be served.

I. Gas mains shall be located a minimum of five feet off the back of the sidewalk on public streets.

J. Gas and water “long side stubs” will be placed five and three feet, respectively, to the right or left of the property line, with gas on the left and water on the right, looking from the street at the lot to be served. See standard drawings for details.

- K. Color coding for utility conduits/lines shall be as follows:
- | | | |
|-----------------|---|---|
| Power | - | Black with red stripe or gray |
| Water | - | Blue or white or ductile iron |
| Sewer | - | Green or white |
| Gas | - | Orange or yellow |
| Phone | - | White or gray and labeled |
| Reuse Water | - | Purple |
| <u>Cable TV</u> | | |
| Falcon | - | Dark green 2" stripe with company label |

2.2.9 DRAWING SUBMITTALS. Four (4) sets of construction plans and drawings shall be submitted to the City Engineer’s Representative for review. Additional sets of drawings in accordance with JUC requirements shall also be submitted to the JUC for review. When all revisions required by the City have been made and the plans accepted, seventeen (17) complete sets shall be submitted to the City Engineer’s Representative for processing. Five sets of plans that have been appropriately stamped as released for construction will be returned to the applicant. One stamped set shall be kept available at the construction site at all times during the construction of the project.

2.3 INSPECTION, TESTING AND QUALITY CONTROL. All construction work involving the installation of improvements in Toquerville City shall be subject to Owner inspection and testing as outlined in the quality control section of each specification.

2.3.1 REQUESTS FOR INSPECTION. A request for inspection shall be made to the City by the person responsible for the construction. Notice shall be given at least twenty-four hours (or as otherwise directed) in advance of the starting of work. Any work requiring backfill or cover shall not be backfilled or covered prior to inspection. It should be noted that any inspection or observation by the City is for the City’s sole use and does not relieve the Contractor or Developer from complying with City standards. The City

provides 'spot' inspections throughout the course of work. These inspections should not be confused with that of providing full time observation or inspection. It is recommended that the Developer retain the use of a professional engineering firm during the course of construction to provide the necessary full-time inspections to ensure that said standards are met and to certify as such. Said certification is required for private developments.

2.3.2 CONSTRUCTION COMPLETION INSPECTION (FINAL INSPECTION).

After all construction work is complete, the Developer shall request a "Construction Completion Inspection". Upon receipt of the request the City shall schedule this inspection with the appropriate parties. Any faulty or defective work shall be detailed in the City's inspection report. All faulty and defective work shall be corrected within 30 days from the date of the City's inspection report. If, after thirty days, the faulty or defective work has not been completed, another "final inspection" may be conducted by the City to determine if additional corrective work is required. The development will not be released and the guarantee period will not commence until all faulty work has been corrected.

2.3.3. GUARANTEE OF WORK. All work shall be warranted and guaranteed to remain in good condition for a period of one year after the date indicated in Section 2.3.2 or as directed by the City Engineer. The responsible party shall agree to make all repairs to and maintain the improvements and every part thereof in good condition during the specified time at no cost to the City. A 10% financial guarantee provided by the Developer of improvements will be required by the City Engineer for the period of the one-year guarantee.

The determination for the necessity of repairs and maintenance of the work shall rest with the City Engineer. His decision upon the matter shall be final and binding. The guarantee hereby stipulated shall extend to and include, but shall not be limited to the entire road base, power system, all pipes, joints, valves, backfill and compaction as well as the working surface, curbs, gutters, sidewalks, and other accessories that shall be constructed.

Whenever, in the judgment of the City Engineer, said work shall be in need of repairs, maintenance, or rebuilding, he shall cause a written or other notice to be served the responsible party and thereupon the responsible party shall undertake and complete such repairs, maintenance or rebuilding. If the responsible party fails to do so within thirty days from the date of the service of such notice, the City Engineer may have such repairs made, and the cost of such repairs shall be paid by the responsible party together with 25 percent of the cost of the repairs in addition thereto, for stipulated damages for such failure on the part of the responsible party to make the repairs. Any omission on the part of the City Engineer, or his designated representative, to condemn defective work or material at the time of construction shall not be deemed an acceptance. The Contractor will be required to correct defective work or material at any time within the one-year before final acceptance.

Prior to the end of the one-year guarantee period, a final walk through for final acceptance will be conducted. All work found to be defective shall be repaired

immediately. Upon completion of these final repairs, the work will be accepted by the City and all appropriate bonds released.

2.3.4 QUALITY CONTROL TESTING. Material testing shall be conducted by an independent testing laboratory. The testing laboratory used for this purpose shall be one that is approved by the City. All testing shall comply with current ASTM, AASHTO, AWWA, Public Drinking Water Regulation standards, or other applicable standards and these specifications. All testing shall meet the minimum testing requirements as outlined in the specifications. The cost of any and all re-testing required to bring materials into compliance shall not be borne by the City. If determined necessary by the City, additional testing may be required.

2.3.5 TEST REPORTS. Written test results will be required for review by the City after each portion of the work (i.e. pipeline construction, earthwork, curb, gutter and sidewalk, roadway construction) has been tested.

A final report of compliance will be required upon completion of the project. This report will include all test results, and any other items required in the plans and specifications.

A certification of compliance with minimum inspection and testing requirements as set forth herein must be submitted for any private subdivision, planned unit development and/or other developments which contain private streets. This certification must be on a form approved by the City and certified to by a Professional Engineer licensed in the State of Utah.

2.4 DRAWINGS OF RECORD. Upon completion of the project and prior to final inspection, a complete set of Drawings of Record that includes all items specified in SECTION 2.2 Construction Drawings shall be submitted to the City. The Drawings of Record shall show all improvement dimensions as they were constructed in the field. The Drawings of Record shall be submitted on twenty-four inch by thirty-six inch Mylar sheets and in electronic format in AutoCAD .dxf or .dwg format in accordance with City policy (unless otherwise directed by the City's Representative). Improvements and any bond held by the City shall not be released until drawings of record are received.

The Developer's Project Engineer shall be required to submit drawings of record containing the signatures of the contractor and the developer's engineer. They shall include a transmittal letter, in duplicate, containing the submittal date, project title, and signature of the Contractor, or Contractor's authorized representative indicating concurrence by the Contractor. The Developer's Project Engineer shall be responsible for the accuracy of the record drawings and shall include a certification by the Professional Engineer, that each drawing of record is complete and accurate.

The submitter shall also provide all drawings of record in AutoCAD format latest update, on a disk with a .dxf or .dwg file format, or as otherwise directed by the City's Representative upon completion of the project.

2.5 BARRICADES AND WARNING SIGNS - WORK AREA PROTECTION. The Contractor shall provide, erect, and maintain all necessary barricades, channelizing devices, lights, warning signs, and other traffic control devices. All necessary precautions shall be taken to protect the work area and to safeguard the public and construction workers. Streets closed to traffic shall be protected by proper barricades, and obstructions shall be illuminated during hours of darkness. Suitable warning and detour signs shall be provided to control and direct traffic properly. All traffic control operations and signing shall be performed in accordance with the instructions outlined in the "Manual on Uniform Traffic Control Devices (MUTCD)", latest edition. A traffic control plan shall be required on each project.

2.5.1 GENERAL TRAFFIC CONTROL REQUIREMENTS. The Contractor shall at all times so conduct his work as to assure the least possible obstruction to traffic and adjacent residents. The safety, convenience, and the protection of persons, property, general public, and residents along the street, highway, and areas adjacent to the work area shall be provided for by the Contractor.

Temporary traffic control devices shall be used to guide and channel traffic through construction areas. Devices shall include cones, portable barricades, vertical panels and other approved devices. Metal vertical panels shall not be used as channelization devices. Traffic cones shall not be permitted as traffic channelizing devices during the hours of darkness.

Advance warning devices shall be used to alert the motorist of an obstruction in the roadway. They include diamond-shaped signs, flags, and flasher type high level warning devices.

All temporary traffic control devices used during hours of darkness shall be properly reflectorized and lighted, in accordance with requirements of the MUTCD. Devices shall have adequate maintenance to retain the reflection and lighting capability. At all times, traffic control devices shall be erect, properly positioned, clean, and in full view of the intended traffic movement.

All traffic control devices shall be immediately removed from roadway or sidewalk when no longer needed.

A traffic lane should be a minimum of ten feet wide. Additional width may be necessary depending on the conditions encountered.

A minimum of two traffic lanes, one for each direction, shall be maintained open to traffic at all times on all major streets unless otherwise approved by the City Engineer.

When two-way traffic cannot be maintained, flag persons shall be provided. Flag persons must be certified and suitably equipped and properly clothed.

Unless otherwise approved by the City's Representative, all existing traffic lanes on major streets shall be maintained open to traffic during peak hours, generally from 7:30 AM to 8:30 AM and 4:30 PM to 5:30 PM weekdays.

Local access shall be maintained to all properties on the project at all possible times. When local access cannot be maintained, the Contractor must notify the affected property owner at least twenty-four hours in advance. Access shall be restored the same day of completion of work which caused loss of access.

A temporary traffic lane shall not be open to traffic unless it is paved with hot mix or cold mix asphalt or graded reasonably smooth and maintained dust free as directed by the City's Representative.

Arrangements for partial or complete street closure permits shall be obtained through the City Engineer or his designated representative. An advance notice of forty-eight hours for major streets and twenty-four hours for local streets and alleys is required. The Contractor shall be required to notify all emergency services (ambulance, fire, etc.) and all other necessary parties as dictated by the City's Representative.

The Contractor is responsible for all barricading, 24-hours a day, 7-days a week. In the event of inclement weather conditions, such as windstorms, rainstorms, etc. the Contractor (or his authorized representative) shall immediately inspect his work area and take all necessary actions to ensure that public access and safety are maintained. In general, trenches and excavations shall not be left open or uncovered over night. Special conditions may be given consideration by the City's designated representative.

The Contractor shall maintain all existing STOP, YIELD, street name signs and other traffic control devices until such time as construction requires their removal. At that time the Contractor shall obtain authorization from the City to remove said signs and posts without damage and deliver them to a storage site as directed by the City Representative. When required, the Contractor may need to install temporary signs (i.e., regulatory signs) until such time as permanent signs can be reinstalled. The City will reinstall all traffic signs.

If at any time project construction shall require the closure or disruption of traffic in any roadway or alley such that normal refuse collection will be interfered with, the Contractor shall, prior to causing such closure or disruption, make arrangements with the appropriate refuse removal service in order that collection service can be maintained.

The Contractor shall provide the City's Representative with a 24-hour emergency phone number of his representative(s) responsible for maintenance of barricades, warning signs and other traffic control devices.

2.6 COOPERATION WITH UTILITIES. The Contractor will notify all utility companies, all pipe line owners, or other parties affected, and endeavor to have all necessary adjustments of the

public or private utility fixtures, pipe lines, and other appurtenances within or adjacent to the limits of construction, made as soon as practicable.

The Contractor shall comply with the requirements of the Blue Stake one call system, in notification to the interested utility owners prior to start of construction. The Contractor shall resolve all problems with the utility owners concerned.

Where water user's association facilities obstruct construction of the work, the Contractor shall contact officials of the association relative to the shutdown of irrigation water and shall acquaint himself with and conform to the requirements of the association.

Water lines, gas lines, wire lines, service connections, water and gas meter boxes, water and gas valve boxes, light standards, cable ways, signals and all other utility appurtenances within the limits of the proposed construction which are to be relocated or adjusted by or under the direction of the facility owners at no expense to the City.

2.7 COOPERATION BETWEEN CONTRACTORS. The City reserves the right at any time to contract for and perform other or additional work on or near the work being done.

When separate contracts are let within the limits of any one project, each Contractor shall conduct his work so as not to interfere with or hinder the progress or completion of the work being performed by other Contractors. Contractors working on the same project shall cooperate with each other as directed by the City's Representative.

Each Contractor involved shall assume all liability, financial or otherwise, in connection with his contract and shall protect and save harmless the Public Agency from any and all damages or claims that may arise because of inconvenience, delay, or loss experienced by him because of the presence and operations of other Contractors working within the limits of the same project.

The Contractor shall arrange his work and shall place and dispose of the materials being used so as not to interfere with the operations of the other Contractors within the limits of the same project. He shall join his work with that of others in an acceptable manner and shall perform it in proper sequence to that of the others.

2.8 CONSTRUCTION STAKES, LINES AND GRADES. The Project Engineer will set construction stakes establishing lines and grades for road work, curbs, gutters, sidewalks, structures and centerlines for utilities and necessary appurtenances as may be deemed necessary. The Project Engineer (or the Developer) will furnish the Contractor all necessary information relating to the lines and grades. Such stakes and marks shall constitute the field control by and in accordance with which the Contractor shall establish other necessary controls and perform the work. A copy of the field notes shall be submitted to the City's Representative upon request.

The Contractor shall perform the work in accordance with construction stakes and marks, and shall be charged with full responsibility for conformity and agreement of the work with such construction markings. When obvious errors or conflicts occur in the staking, the Contractor shall stop work and immediately notify the Project Engineer or the City's Representative.

The Contractor shall be held responsible for the preservation of all stakes and marks. If the construction stakes or marks have been carelessly or willfully destroyed or disturbed by the Contractor, the cost for replacing them will be borne by the Contractor.

2.9 USE OF EXPLOSIVES. The use of explosives or blasting is generally not allowed within the City, however, if explosives or blasting are permitted, their use is controlled by the Uniform Fire Code. The Contractor shall obtain a special permit from the City's Fire Chief for the use of explosives. A copy of this permit shall be delivered to the City's Representative prior to the use of explosives. The approval by the City's Representative for the use of explosives shall not relieve the Contractor from his responsibilities for proper use and handling of the explosives or for any and all damages resulting from their use.

Explosives shall be transported, stored, handled and used in accordance with the provisions and requirements of all applicable laws, ordinances and regulations.

2.9.1 PERMITS AND BLAST PLAN. When any blasting is to occur within the City a permit for such activity shall be applied for at least three working days prior to the desired blasting day. A detailed blast plan shall be submitted for review at the time of application for a permit. The blast plan shall contain the following information:

- A. Number of holes per blast.
- B. Blast pattern.
- C. Depth of holes.
- D. Maximum holes per delay.
- E. Numbers of the delays used.
- F. Type of explosives used.
- G. Total pounds of explosives.
- H. Maximum pounds per delay.
- I. Method of detonation.
- J. Proximity to nearest structure.
- K. Expected duration of blasting activity.
- L. Name of independent monitoring company.
- M. Whether or not pre-blast survey is required and the name of the company doing such a survey.
- N. Plan outline for notification of Fire Marshall, Fire Chief or governing agency one hour prior to detonation of each blast.

2.9.2 GENERAL BLASTING CRITERIA

- A. Blasting activity that is to occur within one thousand (1,000) feet of any school (public or private), university, day care center, church, library, medical facility, or any public building shall be conducted during off hours where possible and shall require seismic monitoring of each blast to ensure the integrity of the building as well as the safety of the occupants of said buildings. Since there is a wide variety in the type density, specific gravity,

velocity and general characteristics within the graphical area of southern Utah, there are varied methods that can be employed to attain the desired results. These methods, if used and however varied, shall adhere to the appropriate limit criteria.

- B. Any blasting that is intended within five hundred (500) feet of any structure (building, tunnel, underground utilities, gas lines, overhead transmission lines, pump station, piping, radio tower, or any other structure of any kind) requires that the blast be monitored with a seismograph capable of measuring peak particle velocities in three spatial components of horizontal, vertical and transverse and be capable of printing this data into a permanent record as digital as well as wave form and air blast overpressure in terms of millibar, PSI or decibel (dB) recording of each event. Any structure such as residential homes, commercial buildings, public buildings, storage facilities, or any other permanent structure that lies within five hundred (500) feet of blasting activity shall be required to have a pre-blast survey performed at the expense of the Contractor and/or the blaster by an independent company whose primary nature of business is to conduct and perform these types of services. The said company shall furnish to the Fire Chief a copy of the pre-blast survey report prior to issuance of the blasting permit. A certificate of insurance issued by an underwriter legally doing business within the State of Utah showing Contractor and/or blaster to be properly insured for the express purpose of blasting and showing the issuing agency as additional insured, shall be submitted with the application of the blasting permit. The amount of insurance shown on the certificate of insurance shall be in the amount required by City's Fire Chief or Owner's Representative. A blasting permit shall be site specific and expire thirty days from issuance.
- C. Furnish and erect special signs to warn the public of blasting operations. Said signs shall be located and maintained so as to be clearly evident to the public during all critical periods of blasting operations.
- D. Notify each public utility company, having structures or facilities adjacent to the work, of his intention to use explosives. Such notice shall be given sufficiently in advance to enable the companies to advise the Contractor of any precautions that should be taken to protect their structures from damage.
- E. Make a survey of adjacent properties, before commencing blasting operations, locating on drawings and by photographs all existing cracks and damages to structures. A copy shall be filed with the Representative, including a report of any property owners who refused to cooperate and permit entry and inspection.
- F. Blasting shall be accomplished in such a manner that nearby buildings, structures, railways, highways, etc. will be safe from rocks and other projectiles. Adequate blasting mats or other means of protection shall be

employed when blasting in congested area or close proximity to any of the above improvements. Steel mats shall not be allowed within two thousand (2,000) feet of power lines.

- G. Immediately prior to the time of firing, the Contractor shall station certified floggers along the road(s) at sufficient distance from the blasting operation to control traffic as required.
- H. The City reserves the right to order the discontinuance of blasting operations at any time.

2.9.3 LOGS. The blaster shall, at the request of The City, surrender logs and records, or a copy thereof, for review within twenty-four hours of receiving such request. Failure to keep current and/or surrender the logs to the City will result in the immediate cancellation of any and all permits issued. No further permits will then be issued within thirty days of submission of said records.

2.10 PROTECTION AND RESTORATION OF PROPERTY AND LANDSCAPE. The Contractor shall be responsible for the preservation of all public and private property and shall protect from disturbance or damage all survey control land monuments and boundary marks. Prior to disturbing any monuments, the Contractor shall notify the City Surveyor who shall require said Contractor to hire a licensed Surveyor to properly reference the monument, unless otherwise directed.

When or where any direct or indirect damage or injury is done to public or private property by or on account of any act, omission, neglect, defective work or materials, or misconduct in his manner or method of executing the work, or in consequence of the non-execution thereof by the Contractor, he shall restore, at his expense and at no cost to the City, such property to a condition similar or equal to that existing before such damage or injury was done, by repairing, rebuilding, or otherwise restoring as may be directed, or he shall make good such damage or injury in an acceptable manner. Said responsibility shall not be released until the project has been completed and accepted.

The Contractor shall not dump spoil or waste material on private property without first obtaining written permission from the property owner. All such dumping shall be in strict conformance with the Grading and Drainage Ordinances.

Prior to any construction in front of driveways the Contractor shall notify the property owner twenty-four hours in advance. Inconvenience caused by construction across driveways and sidewalks shall be kept to a minimum by restoring the serviceability within twenty-four hours, or as otherwise approved by City's Representative. If it is necessary to leave open excavation for a longer period of time the Contractor shall provide structurally adequate steel plates to bridge the excavation.

2.11 SURVEY MONUMENTS. Class I or Class II survey control monuments (as shown in the standard drawings of these specifications) shall be installed on all dedicated and private streets. All survey control monuments shall be installed in strategic locations (as determined by the City's Representative) so as to insure adequate survey control required for subsequent resurvey in the area.

All Class I monuments shall be cross tied and referenced to permanent features and mapped sufficiently for future use in relocation and replacement. All cross tie information shall be submitted to the City Surveyor and should also be kept in a permanent record by the Professional Surveyor doing the work.

Any section, witness or reference corners which fall within roadway or parking lot construction areas shall be reset with a Class I type monument with appropriate cap (as shown in the standard drawings). All corners being replaced shall be referenced in a manner as to accurately reset the corner. A copy of the field notes shall be submitted to the appropriate public agency surveyors for approval before corners are destroyed. The appropriate public agency surveyors (city or county) shall give direction on requirements for referencing of corner(s) to be replaced and the method of reinstallation prior to corner(s) being destroyed.

2.12 HAZARDOUS MATERIALS DISCOVERIES. If suspected hazardous materials (including chemicals, petroleum products, etc.) are encountered, construction operations shall be immediately stopped in the vicinity of the discovery and the proper authority shall be notified of the nature and exact location of the findings. The Contractor shall secure the site of the discovery and shall provide written confirmation of the discovery and proper notification to the City's Representative within twenty-four hours. The written confirmation shall include a statement regarding responsibility to report the discovery to the local health district and the Utah Department of Environmental Response and Remediation within twenty-four hours as required by Federal Statute (40 CFR 280.50) as adopted by the State of Utah. The Contractor or the Property Owner shall then report the discovery as specified in the law.

After operations in the vicinity of the discovery have been restricted, the Property Owner shall keep the City informed concerning the status of the restriction. The time necessary for the Property Owner and appropriate Regulatory Agency to arrange for an acceptable solution to the discovered hazardous material situation is variable and dependent upon the nature and extent of the discovered materials. After clearance is received from the appropriate Regulatory Agency, the Property Owner shall inform the Contractor and the City Representative when work may be continued in the vicinity of the discovery. Written confirmation shall be provided within two calendar days.

2.13 IMPROVEMENT SEQUENCE. Improvements shall generally be installed in the following sequence, unless otherwise directed or approved by the City's Representative.

- A. Construction Traffic Control
- B. Rough grading
- C. Sanitary Sewer
- D. Storm Drainage
- E. Culinary Water
- F. Electrical Service
- G. Telephone
- H. Cable T.V.
- I. Natural Gas
- J. Sub Grade
- K. Sub Base
- L. Road Base
- M. Curb and Gutter
- N. Asphalt and/or Sidewalks
- O. Street Signs and Pavement Markings
- P. Manholes frames & covers and Valve boxes and covers raised to Grade
- Q. Survey Monuments
- R. Clean-up

Please note that this is a general sequence and is not intended to cover all aspects or steps of the construction work.



SECTION 3

DESIGN STANDARDS

3.1 INTRODUCTION. This section defines design requirements for public improvements. It is not the intent of these standards to restrict professional judgement, but rather to serve as a guide and to establish consistency in design.

These standards are the minimum required and should be considered as such. It is recommended that the Engineer in charge review each project on its own merit and impose a higher professional standard as necessary for each project.

3.2 STREET DESIGN. All streets shall be designed to conform to the standards and technical design requirements contained within this sub-section. AASHTO, a policy on geometric design of highways and streets, shall be used as a supplement to these guidelines. In cases of conflict, a determination shall be made by the City Engineer, which determinations shall be final. These requirements may apply as required by sub-ordinance.

These requirements may apply as required by the subdivision ordinance.

3.2.1 STREET CROSS-SECTION STANDARDS. Requirements for the street cross-section configurations are shown in Table 3.1. These requirements are based on traffic capacity, design speed, projected traffic, system continuity and overall safety.

All new developments shall use street cross-sections with fifty feet (50) or more of right-of-way. Access to multi-family or commercial developments, shall use street cross-sections with sixty (60) feet or more of right-of-way.

Alternate road cross-sections incorporating the use of a planting strip may be permitted, if applicable safety and traffic standards are met and approved by the City Engineer.

3.2.2 ROADWAY NETWORK DESIGN. New roadway networks shall be designed in accordance with the general planning concepts, guidelines, and objectives provided within this sub-section.

- The "Quality of Life" for residential occupants shall be a primary concern when designing a residential roadway network.
- An emphasis on proper street hierarchy should be adhered to, namely, local streets should access residential collectors; residential collectors should access major collectors; major collectors should access minor arterials; etc.
- An emphasis on access management should provide control of the location, design, and operation of all driveways, median openings, and street connections to a roadway.
- Roadways should be designed in a curve a linear method in order to reduce, or eliminate, long straight stretches of residential roadways which encourage speeding and cut through traffic.
- Substantial increases in average daily traffic, due to development of adjacent property on established streets not originally designed to accommodate such increases should be avoided.
- Drainage methods should concentrate on meeting the drainage needs while not impeding the movement of traffic (see drainage guidelines).

- Roads should be designed to lie within existing topographic features without causing unnecessary cuts and fills.
- A reduction in the use of cul-de-sacs should be emphasized in order to provide greater traffic circulation and less volume on collector roads. Circulation is of the up most importance, long blocks and excessive dead end streets should be avoided.
- Stopping sight distance should be considered at all intersections and curves to ensure the safety of the public, in accordance with AASHTO standards.
- Pedestrians and bicycle traffic should be considered in the planning and design of all developed streets.

Table 3.1
Street Cross-section Configurations

	Maximum ADT or [D.U.'s]	Traffic Index	Maximum Grade (%)	Right of Way (feet)	Standard Section			Optional Section		
					Pave-ment Width ¹ (feet)	Sidewalk Width (feet)	Right of way (feet)	Pavement Width ¹ (feet)	Planter Width (feet)	Sidewalk Width (feet)
Residential Local	<500 (2 to 50)	5	15	50	32	4	50	29	4	4
Residential Standard	510 to 1,250 (51 to 125)	5	15	50	35	4	53 ⁷	32	4	4
Residential Collector	1,260 to 2,000 (126 to 200)	5.5	15	60	42	5	60	39	4	4
Major Collector ⁵	2,010 to 6,000 (201 to 600)	6	12	66	49	6 ³	70	46	4	5 ³
Minor Arterial ⁵	6,000 to 20,000	7	10	90	67	6 ³	90	65	5	6 ³
Arterial Major ⁵	>20,000	8	8	>100	as req.	6 (min)	>100	as req'd.	6 (min)	6
Commercial Local	NA	10	8	60 ⁶	43 ⁶	6	66	42	4	5
Industrial Local	NA	10	6	66 ⁶	48 ⁶	6	68	45	4	5

11. Pavement width measured from lip of curb to lip of curb.
12. A four-foot wide or wider planter strip shall be placed between the back of curb and front of sidewalk within right-of-way widths shown.
13. A planter strip may be required between back of sidewalk and any wall, fence, hedge, etc. This area can be private or public. If public, additional right-of-way will be required. Alternate sections with meandering sidewalks may be proposed.
14. Not used.
15. Configuration of major collector and higher classifications may be adjusted with proper justification and approval of City Engineer. May require widening at intersections for turning movements. Where on street parking is allowed, additional width and other considerations may be required.
16. The minimum right-of-way and pavement width is shown. Each may be increased when required by a traffic impact study.

17. If approved by the City, a 50' wide right-of-way may be used with the three feet of sidewalk being placed in an appropriate easement.
- NOTE: When approved by the City Engineer, approved modified curb (standard RU30) may be used on the Residential Local and Residential Standard streets using the Optional Section as follows:
- | | |
|---------|---|
| 1 - 100 | ADT (2-10 lots) use Residential Local Optional Section |
| 101-500 | ADT (11-50 lots) use Residential Standard Optional Section. |

3.2.3 IMPROVEMENT REQUIREMENTS. All improvements including, but not limited to the following, shall be constructed in accordance with the standard specifications and drawings unless otherwise approved.

3.2.3.1 Curb, Gutter and Sidewalk. Required curb, gutter and sidewalk shall be constructed.

3.2.3.2 Driveways. Driveways shall be constructed in approved locations.

3.2.3.3 Pavement. All streets, public or private, shall be surfaced to grade, with asphalt concrete pavement, to the required minimum width and thickness in accordance with these specifications.

3.2.3.4 Street lighting. Street lighting shall be provided on all streets. The construction on public streets shall be in accordance with the standard drawings and these specifications. Standard Public street lights may be installed on private streets upon agreement with the City and the local power agency when applicable.

3.2.3.5 Cross Gutters. No cross gutters shall be allowed across major collector or major and minor arterial streets. On commercial and industrial streets, cross gutters are generally not allowed and require approval by the City Engineer for their use. The City Engineer may prohibit construction of cross gutters on any street deemed necessary.

3.2.3.6 Handicap Ramps. When new construction occurs handicap ramps shall be constructed at all street intersections, unless otherwise approved, in accordance with the standard drawings. In addition, when a project occurs where existing improvements are in place, handicap ramps shall be upgraded to meet current standards.

3.2.3.7 Roadway Medians. Medians on public roadways shall be approved by the City Engineer. Design and construction shall be in accordance with applicable standards.

3.2.3.8 Minimum Access. Proposed developments shall have only the required number of accesses to adequately address the needs of the development and only at approved locations. Too many access points or access on major routes hinder the safety and efficient travel of vehicles using these routes. In addition, too few accesses can stifle circulation and unnecessarily concentrate traffic at selected locations.

3.2.3.9 Drainage. Adequate drainage facilities shall be installed to properly conduct runoff from the roadway. Sub-drains and surface drainage facilities shall be designed in accordance with the approved drainage study. Cross gutters shall be used sparingly to maintain the public's driving comfort and in accordance with these specifications.

3.2.3.10 Traffic Control Devices. Appropriate traffic control devices and street signs, as required by the City Engineer, shall be installed in accordance with the MUTCD.

3.2.3.11 Pavement Marking. Appropriate pavement markings, as required by the City shall be installed in accordance with the MUTCD.

3.2.3.12 Street Trees and Landscaping. Street trees and landscaping shall be required in accordance with current City of Toquerville Standards.

3.2.3.13 Other Improvements. The above-required improvements are not all inclusive. Other improvements needed to complete the development in accordance with current engineering and planning standard practice may be required by the City Engineer.

3.2.4 TECHNICAL DESIGN REQUIREMENTS. The following requirements apply to streets.

3.2.4.1 Street Grades

A. All street grades shall have a maximum grade as shown in Table 3.1

B. A request to increase the maximum street grades shown in Table 3.1 may be considered upon submittal of a request and information justifying such a request to the City Engineer. Request for approval must be based upon and in accordance with the latest edition of AASHTO's "A Policy on Geometric Design of Highways and Streets" guidelines. Any approvals for increased grades must be consistent with access requirements of fire apparatus as defined by the Fire Department. The City Engineer's decision will be final. Cost of construction will not be justification for approval.

3.2.4.2 Intersections

A. Wherever possible, all street intersections should intersect at ninety degree angles.

B. In the event an acute angle intersection is proposed, the City Engineer may require mitigation by realigning to achieve a ninety degree intersection. If no other reasonable option for realignment exists, a skew may be allowed up to a maximum of 15° from 90°. Other design approaches to mitigate the skewed angle may be required by the City Engineer.

C. Proper combination of horizontal and vertical alignment should be obtained by engineering study and consideration of the general guidelines listed in

AASHTO (Section Titled: Combination of Horizontal and Vertical Alignment, 1990 edition).

D. Intersections should not be located on the interior of, or near, sharp curves. Intersections should be located a sufficient distance from all curves to provide proper sight distance for vehicles on the intersecting road or driveway and on the through road.

E. New intersections with more than four “legs” are generally not permitted. For arterial access, only four-leg intersections, “T” intersections and modern roundabouts are permitted. When designing local road networks, “T” and “L” intersections are desired. The “L” intersection (knuckle) will only be permitted when the street length, in either direction from the angle point, is three hundred-fifty feet (350'), or less. Four-leg intersections on local road networks are generally discouraged. Where determined that a four-leg intersection is necessary, approval from the City Engineer shall be obtained prior to final design of the local road network. Exceptions to these requirements may be granted by the City Engineer on a case by case basis. The developer's engineer must provide acceptable compelling Traffic Engineering analysis justification before deviations will be granted.

F. When designing local road networks, block lengths without an intervening connector street shall not exceed eight hundred feet (800') in length unless previous approval has been obtained from the City Engineer. Cul-de-sacs are not considered an intervening connecting street.

G. New access locations created by development shall be unified whenever possible to create the fewest number of access points onto arterials or major collectors. Cross use agreements shall be required where necessary.

H. Access to corner lots should be from the lesser-classified road at the greatest distance possible from the intersection, and should no be less than the distances shown below. This distance is measured from the PC of the corner curve. A 25' radius is considered the minimum where the existing radius is less than 25'.

Table 3.2

ACCESS DISTANCE FROM CORNER (in feet)		
Facility Type	Upstream	Downstream
Residential Access	50**	50**
Local Residential	50**	50**
Residential Standard	50**	50**
Residential Collector	100	75
Major Collector	175	150
Minor Arterial *	200	185
Major Arterial *	250	230

- All access points shall be approved by the City Engineer. Distances shown may be increased as required by the City Engineer on a case-by-case basis. Exceptions can only be approved by the City Engineer upon submittal of proper traffic justification.

** Distance shown is preferred. See Section 3.2.4.2.K below or Section 7 of the Toquerville Zoning Ordinance for variations.

I. The intersection of two local roads should be designed to operate with minimal traffic control devices. For example, do not design an intersection to operate with a four-way stop or signal control.

J. Direct access will not be allowed for parking, loading or driveway areas that require backing maneuvers onto major collector or higher order streets. This requirement shall apply to commercial and industrial use regardless of the order or classification of street.

K. Residential and commercial developments are generally required to provide at least two improved accesses to the development depending upon the forecasted traffic volumes. Adjacent developments may be required to combine or share driveway access to public roadways. The access shall be of proper widths to accommodate the calculated traffic volumes and expected vehicle types when the area is fully developed and shall be in accordance with Section 7 of the Zoning Ordinance. Projected traffic volumes shall be calculated using the criteria outlined within the Traffic Impact Study requirements of these specifications.

L. Covered driveways will not be allowed unless approved by the City Engineer.

3.2.4.3 Intersection Spacing. Street intersections shall be spaced far enough apart so that the existing and projected traffic stopped to make left turns at one intersection does not interfere with traffic movements at the adjacent intersection and to not hinder the capacity or safety of the roadway. When a street intersects a low volume residential street, the minimum distance is 150 feet. When a street intersects a minor or major collector street, the minimum distance is 250 feet. Minimum distance measurements are centerline-to-centerline. The minimum spacing requirement on arterials shall be as determined by the City Engineer. Locations shall be based upon a number of items such as projected volumes, turning and stacking distances, intersection spacing, traffic progression, etc. Generally the minimum distance will be 650 feet for arterials and 1/4 mile for major arterials. The City Engineer shall review and give final approval to any intersection requests on arterials.

3.2.4.4 Maximum Design Volume. The maximum design volume shown on Table 3.1 shall be used unless otherwise approved by the City Engineer. A request to increase these volumes may be submitted for consideration to the City Engineer. This request shall include all necessary and required information including support and justification from the Traffic Impact Study.

Conditions which must be considered when reviewing a request for an increase in maximum design volume include hillsides, safety, parking, traffic studies, access requirements, etc.

3.2.4.5 Cul-de-Sac Streets. Such streets shall not exceed six hundred (600') feet in length as measured from center of cross street to center of cul-de-sac. The turnaround pavement radius shall not be less than forty-two and one-half feet (42 ½') (50 feet at property line). Commercial pavement radii shall be no less than forty-seven and one-half feet (47½ ') (55 feet at property line). No road shall be ended without a properly designed cul-de-sac turnaround unless otherwise approved by the City Engineer. Major collectors and higher order roads shall not be permanently dead-ended.

3.2.4.6 Sidewalks

- A. Sidewalk shall be required in all residential and commercial developments. See Table 3.1.
- B. For developments which are within hillside areas, see the City of Toquerville Hillside Ordinance.
- C. Sidewalks in areas of high pedestrian traffic may require greater width as delineated by the City Engineer.

3.2.4.7 Curb and Gutter. All public or private streets shall use curb and gutter of the type shown in standard drawings unless otherwise approved by the City Engineer. In large subdivisions, in rural or agricultural settings, the curb and gutter may be eliminated (although the use of the rural curb is recommended) unless required for drainage or street continuity. When eliminated, roadside drainage and shoulder shall be as shown in standard drawings.

3.2.4.8 Planter Strips

- A. Planter strip areas in road right-of-way must be landscaped with at least fifty percent (50%), by area, of live vegetation.
- B. Xeriscape landscaping must be approved by City's Representative.
- C. Planter strips shall not be filled with concrete or other hard surfaces.
- D. Special drainage requirements may be imposed by City's Representative to protect pavement and curb and gutter from damage due to irrigation of planter strips.

3.2.4.9 Design Speed. The design of geometric features such as horizontal and vertical alignment will depend on the design speed selected for each street. The design speed is primarily determined by the street function and classification, and is the maximum speed for safe and comfortable operation of a vehicle. The use of design speeds other than those listed below must be approved by the City Engineer who may decide that the speed provided in this sub-section be changed to that which is reasonable and prudent under the conditions and having due regard to the actual and potential hazards.

DESIGN SPEED

<u>Classification</u>	<u>Design</u>
Residential Access	25
Local Residential	25
Local Standard	25
Residential Collector	30
Major Collector	35-40
Minor Arterial	40-45
Major Arterial Varies *	(45 min.)
Commercial Local	30
Industrial Local	35

- Variance of design speeds on residential collectors or higher order roads may be granted by the City Engineer to no greater (or less) than five MPH increments when conditions warrant. Variances will not be granted for short segments of roads, but for entire contiguous stretches so that consistency and driver expectancy are maintained.

3.2.4.10 Clear Sight Distance at Intersections. At intersections, adequate, clear sight distance should be provided to permit drivers entering the higher order street from a driveway or STOP-controlled intersection to see approaching traffic from a long enough distance to allow them to decide when to safely enter the higher order street and complete their turning maneuvers in advance of approaching traffic. Clear sight distance, for both left and right turning vehicles, should be in accordance with AASHTO guidelines and generally as follows:

<u>Through Street Design Speed</u>	<u>Sight* Distance</u>
25	290
30	375
35	465
40	575
45	710
50	840
55	980

* Sight distances should be adjusted with cross road grades

3.2.4.11 Vertical Alignment

A. Vertical curves shall be provided in all changes in grade where the algebraic difference is greater than one (1).

B. Longitudinal street grades shall not be less than one-half (1/2%) unless adequate alternative street drainage is provided, nor more than fifteen percent (15%), unless specifically approved by the City Engineer.

C. Vertical curve stopping sight distance design shall utilize criteria recommended by the latest edition of AASHTO. K-values shall be noted on all design drawings.

D. Minimum cross slope from street crown shall be two percent (2%) and the maximum four percent (4%) unless otherwise approved by the City Engineer.

E. Vertical alignment with the intersection is also of special nature, and design alternatives may be required. As a guideline, the approach area where vehicles stop while waiting to enter an intersection should not exceed five percent (5%) from the gutter line of the street being intersected for a distance of fifty (50) feet, though a range of fifty (50) to one hundred (100) feet is more desirable. This applies to all intersections, except those where both intersecting streets are minor or major collectors. In this situation, the landing area for a residential and major collector which is controlled by a STOP or YIELD sign should be designed for a grade of three percent (3%) for a distance of one hundred feet. Any other major intersection streets shall be approved by the City Engineer.

3.2.4.12 Safe Stopping Sight Distance. The minimum sight distance (length of roadway visible to the driver) to be provided for through traffic traveling at, or near, the design speed to stop before reaching a object in its path shall comply with the requirements set forth below (AASHTO guidelines):

<u>Design Speed</u>	<u>Required Distance</u>
25	150
30	200
35	250
40	325
45	400
50	475
55	550

3.2.4.13 Horizontal Curves. The recommended minimum centerline radius for horizontal curves are outlined below.

<u>Design Speed</u>	<u>Curve Radius in Feet</u>
25 MPH	185*

30 MPH	310
35 MPH	419
40 MPH	628
45 MPH	730
50 MPH	926

* For residential streets use 150.

3.2.4.14 Super Elevation

- A. Generally, Super elevation shall not be used on urban roads with design speeds less than thirty five miles per hour unless otherwise approved by the City Engineer.
- B. Maximum Super elevation for urban roads shall be 4 percent (4%) unless otherwise approved by the City Engineer.
- C. The use of Super elevation shall require prior approval from the City Engineer.

3.2.4.15 Deceleration Lanes

- A. Deceleration lanes may be required on streets in conjunction with driveways and/or intersections adjacent to a proposed development. They are specifically required when all of the following factors are determined to apply:
- B. 5,000 vehicles per day are using or are projected to use, the street;
- C. The 85th percentile traffic speed on the street is thirty-five miles per hour or greater; or forty miles per hour for a two lane (one lane each direction) roadway; and
- D. Fifty vehicles or more making right turns into the driveway or street during a one-hour peak period.
- E. The lane lengths for a deceleration lane shall be determined on a case-by-case basis and must receive prior approval of the City Engineer. In addition to the above guidelines, deceleration lanes may be required in connection with the results of a Traffic Impact Study or by the City Engineer.

3.2.4.16 Driveway Profiles. The slope of a driveway can dramatically influence its operation. Usage by large vehicles can have a tremendous effect on operations if slopes are severe. The profile, or grade, of a driveway should be designed to provide a comfortable and safe transition for those using the facility, and to accommodate the storm water drainage system of the roadway.

Required treatments of driveway grades are shown below. In commercial use, while eight percent (8%) should be the maximum allowable initial grade, maximum grades of three percent (3%) are preferable for high-volume driveways and six percent (6%) for low-volume driveways.

For driveways that require steeper grades an engineered design is recommended.

Driveway Type and Adjacent Street Classification	Maximum Grade
Low Volume Driveway** on Local Street*	15%
Low Volume Driveway** on Collector Street	10%
Low Volume Drive** on Arterial Street	5%
High Volume Driveway*** on Any Street	5%
<p>* For single family residential homes these values apply to only the initial 10 ft. of the driveway beyond the sidewalk or right-of-way, whichever applies. ** Low Volume Driveway - defined as a driveway with less than 100 vehicles in the peak hour in the peak direction. *** High Volume Driveway - defined as a driveway with more than 100 vehicles in the peak hour in the peak direction.</p>	
<p>The above requirements apply only to driveways that adjoin public streets and are recommended for those adjoining private streets.</p>	
<p>For grade changes greater than 12%, a vertical curve of at least 10 ft. should be used to connect the tangents.</p>	

3.2.4.17 Alignment and Continuity - Off-Site

A. Normally, off-site pavement construction requires asphalt concrete paving to the right-of-way centerline and in some cases beyond. When asphalt pavement is existing, the developer's engineer shall submit to the City Engineer sufficient information prepared by the Engineer to indicate vertical and horizontal alignments are maintained and adequate drainage is provided for. The developer may be required to replace all, or any portion of existing roadway, in a manner that two-way traffic can be maintained without the use of potentially hazardous alignment transitions (vertical or horizontal) and in a manner to ensure that adequate drainage is provided for. As a minimum, there shall be twenty five feet of paving to accommodate through traffic. Required parking and shoulders are not included in the 25 feet.

When off-site pavement construction consists of improvement to the right-of-way centerline (approximately), leading and trailing transition tapers shall be placed at each end of the improvements. Horizontal transition tapers shall be designed and constructed based upon the roadway speed and in accordance with the taper

requirements in the MUTCD and applicable AASHTO guidelines unless otherwise approved by the City Engineer.

B. When paving for partial street construction, the edges of the pavement are to be protected by placing a minimum two feet of aggregate base material beyond the edge of pavement matching the pavement grade.

C. Wherever partial street construction is required, grades shall be set for the future curb line and approved by the City's Representative. The future grades shall be compatible with the curb and centerline grades for the partial street construction. It may be necessary to design the roadway for a minimum of two hundred (200) feet to as much as one thousand (1000) feet beyond the development to ensure a future match.

D. Where a street abruptly ends or transitions, proper signage according to the MUTCD shall be required. Safe transitions into existing elevations shall be required where new roads transition into existing surfaces, i.e. gravel or natural surface.

3.2.5 PAVEMENT STRUCTURAL DESIGN. The structural details shown on the standard drawings are minimum requirements. The actual structural section for each roadway shall be designed by accepted Engineering design methods for flexible pavement (i.e. AASHTO, UDOT or CALTRANS). Required subgrade soil properties shall be obtained from an on-site geotechnical investigation. Required traffic information for design shall be approved by the City Engineer.

The geotechnical investigation shall be conducted by the Geotechnical Engineer. The investigation shall include a thorough exploration and sampling program of the subgrade to determine the nature and engineering properties of the on-site soils within the roadway construction area. For new construction and reconstruction projects, the minimum sampling and testing requirements are as follows.

- Excavate test holes to a minimum depth of five feet below subgrade. There shall be three test holes for the first one thousand (1000) feet and one for every eight hundred (800) feet thereafter, or as soil type varies.
- Calculate "R" values using AASHTO T 190-93 or ASTM D2844-69 (1975) using exudation pressure of 300 PSI (2070 Kpa) corrected to 2.50 inches (63.50 mm) specimen. Calculate "CBR" values using AASHTO T 193-93 three point using T 180 (Method D) for mold compaction with exceptions as listed in 5.1.1 through 5.1.3 of Test Method T193-93.

Minimum Testing Frequency for "R" or "CBR" values shall be as follows:

Two tests with at least one test per significant soil type for roadway lengths of one foot to one thousand feet.

Three tests with at least one test per significant soil type for roadway lengths of one thousand feet to five thousand feet.

Four tests with at least one test per significant soil type for roadway lengths of five thousand feet to sixteen thousand feet.

Two tests per five thousand feet of roadway with at least one per significant soil type for any roadway over sixteen thousand feet.

- Conduct sieve analysis using either AASHTO T27-91 or ASTM C136-95. Conduct a sand equivalent test to determine the presence or absence of plastic fine material using either AASHTO T176-86(1993) 4.3.2 alternate method No. 2, pre-wet 4.3.3 mechanical shaker or ASTM D2419-91 9.4.2 Procedure B, 11.6.1 mechanical shaker. Either method shall use distilled or demineralized water for the working solution.

One test for each stratum of each test hole.

- Calculate density in place using the drive-cylinder method ASTM D2937-83 or nuclear method ASTM D2922-93.

Two tests per test hole.

- Calculate resistivity and pH using test methods AASHTO T-288-91 and AASHTO T-289-91.

One test for each corrugated metal pipe culvert location.

- Test for soluble salts using Toquerville Standard Test Method S2297-96 at one-third of the number of test hole locations.
- Expansion index of soils shall be determined using the ASTM D4829-88 test method. This test shall be conducted whenever potentially expansive soils are encountered in a test hole.

The above schedule represents minimum sampling and testing requirements. The Registered Professional Engineer responsible for directing and controlling the geotechnical investigation shall analyze each project to determine actual sample locations, frequency and testing program beyond the minimums given above.

The above testing and design requirements may be waived by the City's Representative providing a prior development has already performed the above testing, design and construction on the first half of the roadway in the same location. In this case the new development shall match the existing roadway section.

3.2.6 CURB SIDE MAIL BOXES. All roadside mail boxes should be installed in accordance with applicable postal standards in the following locations: In areas where the sidewalk is next to the curb, install boxes behind the sidewalk so as to not encroach into the sidewalk; in areas where a planter strip is provided, mail boxes may be installed within the strip, provided no part extends into the sidewalk or beyond the back of the curb; in rural areas where no barrier curb is installed, a minimum clear zone of ten feet from the traveled way should be provided.

3.2.7 SIGNS AND PAVEMENT MARKINGS. All street name and traffic control signs and pavement markings required on the street system within development or as a result of the development, shall be installed at the developer's expense in accordance with the standard drawings and MUTCD standards. A signing plan should be submitted with the engineering drawings, however, additional signing and traffic control may be added to the project as determined by the City's Representative.

3.2.8 UNDERGROUND WATER. When underground water in or adjacent to the site is encountered by geotechnical investigation or during the construction work, the City's Representative and the Project Engineer shall be notified immediately. The Project Engineer shall cause the necessary studies to be made and the required mitigation work to be installed. Do not ignore the situation!

3.3 OFF-SITE IMPROVEMENT SOIL STUDY GUIDELINES. The construction of off-site improvements is subject to the recommendations of a soils investigation report. This information shall be submitted at the same time off-site improvement plans are submitted to the City Engineer. The findings contained in the soils report shall be used as the basis for the design and construction of the off-site improvements unless otherwise directed by the City's Representative.

The soils investigation shall be conducted by the Geotechnical. The report shall be sufficiently comprehensive to determine the location and nature of all soils within the off-site construction area.

3.4 DRAINAGE AND FLOOD CONTROL DESIGN. This sub-section sets forth the criteria for engineering design of drainage and flood control systems.

3.4.1 GENERAL REQUIREMENTS. All development in the City that requires a grading permit or exceeds one acre in area, and all commercial development, shall submit a Drainage Control Plan and Report.

Design of drainage systems associated with development cannot cause increases in the flood peak discharges downstream from the development for 10-year and 100-year flood events.

All drainage plans shall conform to the requirements of the General Drainage Manual and be approved by the City Engineer or his designee.

Drainage and flood control plans shall be approved by the City Engineer.

Drainage facilities shall be designed using currently accepted civil engineering standards of practice, applicable safety standards, and City or other approved design specifications.

In general, each development should handle its storm water runoff in such a manner that no increase in the 10 or 100-year peak storm runoff above the pre-development and/or natural state will occur on downstream properties.

In general, development changes the characteristic (quantity) of drainage from sheet flow to point discharge flow. While the amount of water may be controlled, the effects of all point discharges must be handled to insure no detrimental effects downstream of development.

Drainage facilities should be analysed, designed, and constructed to protect the development from the 100-year peak storm runoff. Most drainage collection system capacities for new development will be sized for the 10-year flood event, but no significant damage or risk of personal injury may occur from the 100-year flood. Major hydraulic structures (including bridges, large culverts, and open channels) will be designed for the 100-year flood.

For analysis purposes of the drainage system of a drainage basin area, all of the drainage basin upstream of the proposed development should be analysed for the conditions of new and/or planned development in conformance with the City's current Land Use Master Plan. Effects on downstream property owners and downstream flood control system shall be considered in the design and any negative impacts mitigated or design changes presented to mitigate problems to the satisfaction of the City Engineer or his designee. This may include acquisition of easements or agreements and/or construction or modification of existing improvements where needed both within the development and/or downstream.

All storm drainage and flood control systems shall be separate and independent from the sanitary sewer system.

New development should not cause a natural drainage channel to be filled in, obstructed, or diverted. When modifications to a natural drainage channel is proposed within the development, such changes will be addressed in the Drainage Control Plan and Report and shown on the improvement plans, and must be approved by the City Engineer prior to proceeding. In the event that modifications to natural drainage channels are approved, necessary easements and rights-of-way for structures and improvements shall be provided to the City.

The point at where the natural drainage channel enters and leaves the property will not be changed without approval of the City Engineer.

Improvements designed to protect a development shall be considered permanent and shall be designed and constructed accordingly. Such improvements shall be easily maintained by the maintaining agency.

New development shall provide the necessary means to insure drainage within the property being developed makes use of existing facilities and/or natural washes and shall be required to construct master planned improvements.

Streets are a significant and important component in urban drainage and shall be made use of in storm runoff within reasonable limits. The primary purpose of streets is for traffic. Reasonable limits for the use of streets for runoff shall be set by the City Engineer.

When drainage encroachments beyond that allowed for in the streets or point discharges are exceeded, an independent storm water system shall be designed and constructed by new development.

3.4.2 DESIGN CRITERIA - STREETS. Streets are a significant and important component in urban drainage and may be made use of in storm runoff within reasonable limits. The primary purpose of streets is for traffic. Reasonable limits for the use of streets for runoff shall be set by the City Engineer. Design criteria for gutter capacity and associated lane encroachment will depend on the roadway type as shown in Table 3.3. Street designs must include surface drainage relief points (inlets). This is especially important for flat gradient areas, local sumps or depressions and cul-de-sacs. For pedestrian safety, street flows must be limited such that the product of the depth (ft.) and velocity (ft./sec.) does not exceed six (6) for the 10-year flow and eight (8) for the 100-year flow. Curb overtopping is not permitted in the 10-year event. When street encroachment limits are met, an underground storm sewer system shall be required. Where this underground conveyance is required to limit street flows, it will be designed for the 10-year design storm or greater.

Table 3.3

Street and Gutter Capacity for the 10-year Event	
Street Classification	Maximum encroachment
Local (residential)	No curb overtopping.* Flow may spread to crown of street.
Minor collector (residential); Commercial	No curb overtopping.* Flow spread must leave one lane free of water.
Major Collector	No curb overtopping. * Flow must leave at least two lanes of travel free. (One lane in each direction)
Arterial	No Curb overtopping.* All travel lanes to remain open.
Major Arterial	No Curb overtopping.* No encroachment is allowed on any traffic lane.

* Where no curb exists, encroachment shall not extend over property lines.

Streets must also provide for routing of the 100-year design storm to adequate downstream conveyance facilities. The 100-year flood flows in streets should be contained within street right-of-way and adjacent drainage easements.

3.4.3 DESIGN CRITERIA - STORM DRAINS. Storm drain design conveyance capacity will be sized for a minimum of the 10-year, three hour flood. The 100-year, three-hour design flood will be used for evaluation and prevention of significant damage to street overflow. Inlets must have sufficient capacity to prevent local ponding during the 10-year event, with fifty percent (50%) blockage of inlets by debris. Analysis of combined street and storm drain capacity for the 100-year flood must determine maximum ponding depths and water levels and show that these depths are non-damaging. In instances where sufficient combined capacity does not exist the storm drain size may have to be increased beyond that of the 10-year design.

In areas where underground water is anticipated to be added to the drainage system, the pipe size should be increased accordingly. In general, ground water will not be allowed to flow in streets and gutters and in other overland flow situations.

Design considerations will be given for differences in interception capacity of inlets on a gradient as compared to interception capacity of inlets in sag locations. Inlet spacing and locations will be for continuous grade or sag situations as appropriate. Inlets will be spaced so as to keep the street encroachment of flood waters to the minimum. Sag points may be required to have additional inlets spaced to control the maximum level of ponding.

All storm drains will be designed by application of the Mannings equation. Minimum design velocity shall be two ft./sec. flowing one-half full. The mannings "n" value shall represent that value that will be seen during the useful life of pipe which may differ from that of a new pipe. The hydraulic grade line will be shown for all pipe systems. The minimum storm drain diameter shall be 12" for smooth wall (insides) and 15" otherwise.

Storm drains shall not be designed for surcharged (pressure) pipe conditions unless otherwise approved by the City Engineer. When storm drains are designed for full pipe flow, or surcharged pipe conditions, the designer shall establish the hydraulic grade line considering head losses caused by flow resistance in the pipe, and changes of momentum and interferences at junctions, bends and structures. The water surface elevation profile and hydraulic grade line will be shown for the ten year and the 100-year design flood as required in the Drainage Control Plan and Report.

3.4.4 DESIGN CRITERIA - CULVERTS. In general, culverts are used to carry runoff from an open channel or ditch under a roadway to a receiving open channel or ditch. The minimum culvert diameter shall be 24". All culvert crossings under a roadway shall be designed to handle the 100-year storm (see bridges). All culvert crossings under arterial roads shall not have any road overtopping. Any other road overtopping shall be limited by the velocity/depth product and as detailed in Section 3.4.2.

A culvert entrance blockage factor of up to fifty percent (50%) shall be used for small diameter culverts and culverts placed in drainages with upstream debris as determined by the City. The 100-year design storm water backwater surface upstream will be determined using an approved method (generally a HEC-2 or HEC-RAS) unless otherwise not required by the City. The back water must be shown to be non-damaging and be approved by the affected property owner. Potential paths of embankment overtopping flows will be determined and redirected, if necessary, so that no significant flood damage occurs. Entrance and exit structures must be installed to minimize erosion and maintenance. The minimum culvert slope shall be one percent (1%) unless otherwise approved.

3.4.5 DESIGN CRITERIA - BRIDGES. Bridges consist of major structures carrying major washes or drainages. The roadway facility handled can be any classification of roadway. Low water crossings are generally not permitted. Bridges can consist of free span structures, box culvert, multiple box culverts, multiple precast bridges and others.

Free-span bridges must pass the 100-year event with a minimum of two feet of freeboard. No significant increases are allowed in upstream water levels. An approved method (generally a HEC-2 or HEC-RAS) of potential upstream water surface may be required by the City. Local and regional scour analysis is required on the structure, upstream and downstream and embankments. All potential scour will be mitigated. Appropriate references for this are Stream Stability at Highway Structures, Hydraulic Engineering Circular No. 20, Federal Highway Administration and computer programs such as USCOE HEC-6 or FHWA FESWMS.

For structures crossing FEMA designated flood plains and drainages, other requirements will be used, consult the City Engineering Dept.

3.4.6 DESIGN CRITERIA – CHANNELS

3.4.6.1. Open Channels. Generally, there are two types of channels, they are man made and natural. Natural channels can be further subdivided into several sub-categories such as un-encroached, encroached, partially encroached, bank lined and others. The 100-year recurrence flood will be used for design for all channels unless otherwise approved by the City. All open channels must be designed as permanent in nature and have a minimum freeboard of one (1) foot. They must be designed as generally low maintenance facilities and must have adequate access for the entire length.

3.4.6.2. Man-made Channels. Man-made channel side slopes will generally be limited to a maximum slope of 2H:1V. Flatter slopes are generally recommended for maintenance and safety reasons. Safety is a primary concern. A channel should be designed such that a person falling into it could climb out within a reasonable length. A channel that is shallow in depth or in remote areas, or in areas of restricted right of way may, upon approval, have a steeper slope. Maximum velocities will depend on the type of material used for the channel lining. Supercritical velocities are not permitted for any material used. Drop structures and other energy dissipating design may be required to limit velocities to control erosion and head cutting.

Maximum velocities for grass lined channels depend on the type(s) of grass mixtures. The designers should consult appropriate design literature for details. It is assumed that grass lined channels will be mowed at least annually. The minimum bottom width of a grass lined channel will be 6 feet unless otherwise approved by the maintenance agency. The minimum bottom width of all man-made channels shall be designed to facilitate access and maintenance.

3.4.6.3 Natural Channel. The use and preservation of natural drainage ways shall be encouraged. Natural channels for drainage conveyance can reduce long term maintenance costs, can reduce initial costs associated with drainage, and can enhance passive recreation, and open space uses. When natural channels are incorporated into the drainage control plan, consideration shall be given to the impact of increased flows due to improvements to upstream drainage basins and areas, adequate access for maintenance and debris removal, long term degradation and erosion potential, and the need for additional set-backs for structures.

3.4.7 DESIGN CRITERIA - STORAGE FACILITIES. Generally, there are two types of storage: retention and detention. Retention ponds which are normally intended for infiltration of stored water may require extensive subsoil and groundwater studies as well as extensive maintenance requirements and safety concerns and are generally not allowed.

Detention facilities (basins) are used to temporarily store runoff and reduce the peak discharge by allowing flow to be discharged at a controlled rate. The controlled discharge rate is based on either limited down stream capacity, as in regional basins, or on a limit on the increase in flows over pre-development conditions, as in local facilities, and in some instances both.

Regional detention facilities are those identified by the City and will be identified in the Master Storm Drain Study and other regional studies. Generally, these facilities control flow on major washes or drainage basins, are of major proportion, and are built as part of major development or mitigation plans.

Local detention facilities are usually designed by and financed by developers or local property owners desiring to improve their property. These facilities are intended to allow development of property by protecting a site from existing flooding and/or to protect downstream property from increased runoff caused by development. In small facilities, detention storage volume may be provided in small landscaped or turfed basins, parking lots, underground vaults, excess open space, or a suitable combination. In larger facilities, dual functions may be served. These larger facilities are required to reduce existing flooding to allow a development and/or control increased runoff caused by the development itself. These larger facilities may store significant flood volumes and may handle both off-site and on-site flows.

3.4.7.1 Design Criteria. Detention facilities will generally be used to prevent local increases in the 10-year, 72-hour and the 100-year, 72-hour peak flows, or the 100-year 3-hour storm, whichever case requires the largest volume. Post-development discharges must not exceed pre-development discharges. If downstream facilities lack adequate capacity to handle the flow, other release rates must be used.

Standard engineering practice shall be used in determining the volume of the required facilities. A minimum of one (1) foot of freeboard is required above the maximum water surface elevation. Emergency spillways or overflows will be incorporated into all designs. Structures and facilities shall be designed so as not to be damaged in case of emergency overflow. Detention basins must empty within 24 hours. The maximum depth of a basin should be three (3) feet unless otherwise approved. Below grade basins are preferred. Partially wet basins may be allowed for recreational or aesthetic purposes, but storage below permanent spillways or low-level outlets cannot be included in control calculations. Ground water should not be introduced into detention basins without approval of the City. Multi-use (e.g. recreation) should be considered for all detention basins.

Energy dissipation and erosion protection is required at all outlet structures where storm drainage is released into a natural or erodible channel, unless otherwise approved by the City. All basins are required to function properly under debris and sedimentation conditions. Adequate access must be provided to allow for

cleaning and maintenance. All basins shall be designed as permanent facilities unless otherwise approved in writing by the City.

3.4.8 FLOODPLAINS. Flood plains are generally classified as FEMA (FEMA stands for Federal Emergency Management Agency) and non-FEMA. Any work in and around FEMA designated and mapped Flood plains should refer to the local ordinance governing their use. All work in the FEMA floodplain requires an appropriate permit.

3.4.8.1 Flood Plains (NON-FEMA). In general, all building floor levels should be constructed two feet above the 100-year flood level. Encroachments into the 100-year floodplain for natural water courses will not be permitted unless otherwise permitted by the City. All natural drainages, washes, and waterways that convey a developed 100-year flow of greater than 150 cfs will be left open unless otherwise approved. Developments located adjacent to or in Flood plains may be required to stabilize the continual degradation and erosion of the channel by installing grade control structures and/or by other effective means. Any alteration of the floodplain is not permitted unless the proposed use can be shown to have no significant negative influence on the flood conveyance, the floodplain, or the alteration itself.

In the layout and design of new developments, adequate access to Flood plains and erosion protection shall be provided. It is preferred that streets be positioned between Flood plains and structures. Where not possible or feasible, additional structural setbacks will be required.

Hydrologic, hydraulic, erosion, and geomorphologic studies will be required of developments adjacent to Flood plains.

3.4.9 EROSION CONTROL. Necessary measures shall be taken to prevent erosion due to drainage at all points in new developments. During grading and construction, the developer shall control all potential storm runoff so that eroded soil and debris cannot enter any downstream water course or adjoining property. All drainage that leaves a new development shall be adequately addressed to mitigate all erosion on adjacent properties. Erosion mitigation shall be permanent unless otherwise approved. A comprehensive reference on erosion control is Sedimentation Engineering by the ASCE.

3.4.10 IRRIGATION DITCHES. In general, irrigation ditches shall not be used as outfall points for drainage systems, unless such use is shown to be without unreasonable hazard substantiated by adequate hydraulic engineering analysis.

3.4.10.1 Use of Ditches. The irrigation ditches running through the area are laid out on very flat slopes and with limited carrying capacity. It is obvious, based on experience and hydraulic calculations, that irrigation ditches cannot, as a general rule, be used as an outfall point for storm drainage because of physical limitations. Exceptions to the rule are when the capacity of the irrigation ditch is adequate to carry the normal ditch flow plus the maximum storm runoff with

adequate freeboard to obviate creating a hazard to those below and around the ditch. Ditches are almost always totally inadequate for use as drainage ways.

Irrigation ditches are sometimes abandoned in areas after the agricultural land is no longer farmed. Provisions must be made for ditch perpetuation prior to its being chosen and used as an outfall for drainage. Use of irrigation ditches for collection and transportation of storm runoff shall be made only when in accordance with the basin master plan.

3.4.10.2 Irrigation Company Approval. Any use of, alteration of, or relocation of structures on any irrigation ditch (or canal) shall have the written approval of the irrigation company who shall take the responsibility thereof.

3.5 SANITARY SEWER DESIGN AND STANDARDS. SEE ASH CREEK SPECIAL SERVICE DISTRICT STANDARDS AND SPECIFICATIONS.

3.6 CULINARY WATER DESIGN. All culinary water mains and appurtenances within the City of Toquerville shall be designed to provide for adequate future service for all contiguous areas which may, within a twenty year period in the future, be tributary thereto. Water trunk lines shall be designed in accordance with the system master plan.

3.6.1 DESIGN FLOW PRESSURE. Water mains shall be designed to provide a minimum residual pressure of twenty (20) psi under maximum day demand conditions including designed fire flow (as called out in SECTION 3.6.7 of these Standards). A minimum of forty (40) psi residual pressure must be maintained under normal peak hour conditions without fire flow.

3.6.2 FLOW DESIGN CRITERIA. Flow design criteria shall conform to the requirements outlined in the current edition of the State of Utah Rules for Public Drinking Water Systems, Section R309-1-5 "Quantity Requirements" and R309-112 "Distribution System". In any case where these specifications require a higher design standard than is contained in the referenced Rules, the higher design standard shall take precedence.

Peak instantaneous flow for outdoor use shall be assumed as follows:

Indoor Peak Instantaneous Flow multiplied by two.

Peak instantaneous fire flows shall be added to peak instantaneous domestic flows for distribution system design flow total.

Commercial or industrial areas may require special investigation to determine fire flow requirements. Existing and future static pressure and flow information used in the design must be approved by the City.

3.6.3 MINIMUM SIZE AND DEPTH. The minimum depth of cover (to the top of the pipe) for water mains shall be three feet below the final grade of the street with a maximum of 10 feet unless otherwise approved by the Water Department. Where final grades have not been established, mains shall be installed to a depth great enough to ensure a minimum of three feet and a maximum of 10 feet of cover below future grade. The water mains shall be sized to deliver the peak instantaneous flow rate as previously outlined. The fire flow requirements and pressures shall be as previously outlined. The size of the pipe shall also be based on a five (5) foot per second (fps) velocity maximum at peak instantaneous flows. However, the minimum water main size to be installed shall be eight inches in diameter unless otherwise approved by the Water Department.

Departures from the minimum requirements will be considered only in special circumstances. Water mains in cul-de-sacs, internal streets within subdivisions, and other areas where water mains will not be extended in the future, may be six inches in diameter if that size water main meets the development's water demand requirements. Any departure from minimum requirements identified above shall be justified by a network hydraulic analysis.

A fire hydrant shall not be connected to a main which does not have sufficient fire flow capacity.

In locations where the City has determined line size for the future based on a Master plan Study, the master-planned line size will be installed.

3.6.4 VALVES AND HYDRANTS. The water system shall be looped and valves shall generally be spaced such that a break in any one length of main will put no more than six hundred feet of main, nor more than two fire hydrants, out of service (whichever is less) while maintaining adequate minimum service in the remainder of the water system during repairs, except for major transmission lines, where longer spacing may be allowed. All distribution mains connecting to larger transmission mains shall be valved at the connection. All fire hydrant runs shall also be valved at the distribution main.

Valves shall generally be located at street intersection.

3.6.5 PRESSURE REDUCING VALVES. Pressure reducing valves shall be installed on main lines where designated by the City Water Department. The standard design for these pressure reducing valves and vaults shall be provided by the City Water Department.

3.6.5.1 Secondary Pressure Reducing Valves. The Water Department requires that in high-water-pressure zones (greater than 80 psi), secondary pressure reducing devices be installed by the building owner on all water connections to buildings. The locations of the high-water-pressure zones within the City can be located and identified upon request from the System Owner.

3.6.6 FIRE HYDRANT SPACING AND LOCATION. Generally, fire hydrants shall be spaced and located as follows:

3.6.6.1 At each intersection, generally on the same sides of the street.

3.6.6.2 In residential areas, fire hydrant spacing shall be no greater than 500 feet and no house shall be more than 250 feet from a hydrant measured along a street access to the property being served.

3.6.6.3 In multiple family areas, PUD zones, P.D. zones, industrial, business or commercial areas, fire hydrant spacing shall require special investigation to determine the hydrant spacing per Appendix 111-B of the Uniform Fire Code (UFC). (Generally, spacing shall be no greater than 350 feet and all commercial buildings shall be within 175 feet of a hydrant.)

3.6.6.4 Generally, hydrants shall be located in line with extensions of the property line when located mid-block.

3.6.6.5 Hydrants shall be placed no more than five (5) feet from the back of the sidewalk. Where sidewalk is not adjacent to the curb and a four (4) foot wide or wider planter area exists, the hydrant may be placed in the planter no closer than two feet from the back of the curb. Provide a five (5) foot elliptical radius of clearance to adjacent obstacles with the lowest water outlet not less than eighteen (18) inches or more than thirty (30) inches from the final ground elevation (see standard drawings). The "break-away" flange at bottom of hydrant shall be installed so that it is at, or within six (6) inches above, final ground elevation.

3.6.6.6 All fire hydrants shall be owned and maintained by the Water Department and shall be installed on dedicated easements or public rights-of-way.

3.6.6.7 A fire hydrant shall be placed in the end of all cul-de-sacs or on dead end lines.

Fire hydrants shall not be located:

A. within five (5) feet of a driveway, power pole, light standard, or any obstruction

B. or, within three (3) feet of any block wall or fence when measured to the rear of the hydrant.

3.6.7 FIRE FLOW REQUIREMENTS. Under maximum day demand conditions, fire flow shall be at least 750 gallons per minute at any one hydrant with a total fire flow of at least 1,500 gpm at any combination of two hydrants in the area, and/or must meet the requirements of the Federal Insurance Service Office. The total system design shall be such that fire flows and normal peak instantaneous flow demand (as called out within this sub-section) can be met while still maintaining a minimum pressure of twenty (20) psi at all points in the distribution system.

A maximum water velocity of ten (10) feet per second shall be utilized when designing for fire flows and/or other emergency conditions.

High density residential, commercial or industrial areas shall require special investigation to determine fire flow requirements and hydrant spacing per the Uniform Fire Code (UFC).

Existing and future static pressure and flow information used in the design shall be approved by the Water Department.

3.6.8 MISCELLANEOUS WATER SYSTEM DESIGN CRITERIA.

3.6.8.1 All public water mains shall be installed in a public rights-of-way, dedicated roadway, or designated drainage way, with adequate access for maintenance vehicles. Pipelines will not be installed on back lot or side lot lines due to potential flood and other damage.

3.6.8.2 Dead-end mains shall be avoided wherever possible and if installed, shall not exceed six hundred feet. Hydrants shall be located at the end of dead-end mains and cul-de-sac mains for flushing purposes as well as for fire protection. Blow-off valves rather than fire hydrants are not desirable except where warranted by special circumstances as determined by the Water Department. Blow-off valves shall be installed per the standard drawings.

3.6.8.3 Each building or lot shall be served by a separate line and meter except in PUD's as approved by the Water Department. In some situations a common tap and service line from the main to a manifold with two meter setters and boxes may be installed to serve two adjacent properties. All lots shall have a minimum of three quarter (3/4) inch service line from the main to the meter box. Multiple housing of two units, or more, shall have a minimum of one (1) inch service. When there are more than two multiple housing units the service line shall be sized accordingly.

3.6.8.4 All service line taps shall be machine tapped at the time of the water main installation. Service lines shall be installed prior to testing and acceptance of the water main.

3.6.8.5 Water mains shall be laid at least ten (10) feet horizontally from any existing or proposed wastewater main. The distance shall be measured edge to edge. If necessary, and where approved by the City's Representative, SECTION 12.2.1 of the State of Utah Public Drinking Water Regulations can be implemented.

3.6.8.6 When a water main crosses over a wastewater main, the water main shall be laid at such an elevation that the bottom of the water main is at least eighteen (18) inches above the top of the wastewater main. When the water main cannot be as high as eighteen (18) inches above the wastewater main, the wastewater main shall be constructed of material with pressure conduit standards for a distance of ten feet on either side of the crossing.

3.6.8.7 All tees, bends, plugs and hydrants shall be provided with reaction blocking, tie rods, and/or joints designed to prevent movement, i.e. "mega lug" or approved equal. Wood blocking of future main extensions is not acceptable. When thrust restraints cannot be used, concrete thrust blocks shall be formed and poured in place and must bear against undisturbed soil, per the thrust block details in the standard drawings. Installation of concrete thrust blocks shall receive prior approval of the Water Department.

3.6.8.8 Air release vacuum assemblies and blow-off valves shall be provided on all mains twelve inches in diameter and larger, where required, to prevent damage due to air accumulations.

3.6.8.9 All water lines shall require a 14-gauge insulated THWN wire be installed with the line for locating purposes. The wire shall be installed and extended up at each valve and hydrant.

3.6.8.10 Sufficient valves shall be provided on water mains to minimize inconvenience and sanitary hazards during repairs. Valves shall be generally located as follows:

- A. At intervals to isolate no more than two (2) fire hydrants at any time.
- B. At minimum intervals of 500 feet in commercially zoned areas.
- C. In residential areas to isolate a maximum of thirty services (approximately 600 feet).
- D. A maximum of five (5) valves will be required to isolate any location.

E. Valves shall not be located in street gutters, valley gutters, or in driveways.

F. A valve is required at the end of all temporarily dead-ended mains. The valve location is to be a minimum of ten (10) feet upstream of the cap or blow off assembly.

G. Valved outlet(s) for future service laterals six (6) inches in diameter and larger may be installed when approved by the Water Department. (Valved outlet installation approval does not constitute a water commitment.)

H. A shut off valve immediately adjacent to the water main shall be provided for all service laterals greater than two (2) inches in diameter and for all fire hydrant laterals.

I. The Water Department may require additional valves as deemed necessary.

3.6.9 NETWORK HYDRAULIC ANALYSIS.

3.6.9.1 WHEN REQUIRED. The Water Department may require that a network hydraulic analysis be conducted by the Engineer if:

- the project is a major subdivision with an internally looped system
- the project is located in the higher elevations of a low static pressure zone
- a high fire flow demand is required (greater than 1,500 gallons per minute)
- there will be extensive irrigation
- the new water plans will complete a loop on the current system, or
- as otherwise required by the Water Department.

3.6.9.2 DESIGN. The consulting engineer should request the source hydraulic grade line (HGL) from the water department prior to the initial design where a network hydraulic analysis is required. The following information shall be submitted at the time of such a request:

- location, type of development, and the acreage or number of units with the development, and
- anticipated fire flow requirements, and
- the location where the proposed water distribution system is planned to tie into the existing system.

3.6.9.3 SUBMITTAL FOR REVIEW AND APPROVAL. The network hydraulic analysis shall be submitted with the project design for review. For larger projects, such as a major subdivision, obtaining network hydraulic analysis

approval prior to submitting the water plan is preferred. The Water Department shall, upon request, make a determination as to which submittal method must be followed.

The network hydraulic analysis submittal shall include two copies of the following items:

- the data input sheets, as well as the analysis results
- information about the development (i.e., type, number of acres, number of units, fire flow requirements, etc.)
- data sheet(s) outlining all assumptions (i.e, method used to assign demands to corresponding nodes and source HGL's used)
- map identifying pipe and node numbers and their locations
- fire hydrant locations
- the name and version of software used for the analysis
- elevations of junction nodes
- staging or phasing of development, and
- appropriate off-site demands.

3.6.9.4 MISCELLANEOUS. The roughness factors to be used in the analysis should be as follows:

- C equal to 100 for all unlined cast iron pipe
- C equal to 120 for existing pipe twelve inches, or less, in diameter
- C equal to 130 for existing pipe (150 for PVC) fourteen inches, or greater, in diameter
- C equal to 130 for new pipe (150 for PVC) regardless of diameter

For any other sizes or materials not covered by the above, the consulting engineer shall contact the Water Department for guidance.

When identifying the fire flow available in a network hydraulic analysis, use the hydrant located at the development's weakest point (highest point in the development and/or last hydrant on dead-end main). Also, verify the hydrant is located at a junction node.

The elevations used in the network hydraulic analysis should preferably be based on a project grading plan or the anticipated final elevation. If the final grading plan deviates significantly from the elevations used in the analysis, a revised analysis will be required.

A chart to be used as a guide to determine water consumption for various types of developments shall be obtained from the Water Department.

3.7 SECONDARY WATER OR WASTEWATER REUSES IRRIGATION SYSTEM. All secondary water irrigations systems shall be designed and constructed in accordance with the requirements outlined for culinary water systems in SECTIONS 3 and 4 of these specifications. However, all valve box covers shall bear the legend "Irrigation" in order to clearly differentiate between culinary and secondary systems. The pipe material shall be colored purple, or a discrete color different from the culinary water main. There shall be no cross connections between secondary and culinary water systems.

All wastewater reuse irrigation systems shall be designed and constructed in accordance with the requirements outlined for culinary water systems in SECTIONS 3 and 4 of these specifications. However, all requirements for the treating and reuse of wastewater outlined in the latest applicable Utah Division of Water Quality Standards for Utilization and Isolation of Domestic Wastewater Treatment Works Effluent shall be followed. These requirements include, but are not limited to, a reuse project plan, allowed uses, required treatment processes and water quality limits.

3.8 OTHER UTILITIES SYSTEMS DESIGN. All other utility systems shall meet the following:

3.8.1 RESPONSIBILITY. Other necessary utility installations (Gas, Electricity, Phone, T.V.) will be coordinated and installed by the developer.

3.8.2 STREET LIGHTS. All developments shall include street light and necessary appurtenance in accordance with the local power company's specifications.

3.8.3 BURIAL OF LINES. All utility lines in subdivisions, planned unit developments, and other developments shall be underground. Lines shall be buried at a minimum depth of forty-two (42) inches for primary power. Power lines shall not be buried in any water or sewer trench.

3.8.4 LAYOUT. Utility lines shall be located within designated utility easements and in accordance with the requirements of the Joint Utilities Committee (JUC).

3.8.5 FRONT LOT LINE SYSTEMS. Where utilities are located in front lot lines, other utility system construction shall not begin until the completion of water, sewer, curb and gutter, and must be complete before installation of street asphalt.

3.8.6 QUALITY CONTROL. All utility trench construction shall conform to the design and testing requirements set forth in Section 4.4 (Pipeline Construction) of these standards.

3.9 TRAFFIC STANDARDS. This sub-section sets forth the criteria for access control and Traffic Impact Studies.

3.9.1 ACCESS CONTROL. The general access control requirements for “major” and “minor” arterials and “major” collectors are provided below. All access points on these facilities shall be subject to approval by the City Engineer or his designated representative. Where necessary, stricter requirements deemed may be evoked.

3.9.1.1. GENERAL REQUIREMENTS. Direct access to a residential lot(s) shall not be allowed unless otherwise approved by the City Engineer. If allowed, additional requirements and restrictions may be imposed such as increased setbacks, circular drives, etc.

A. Driveway access shall not be allowed within one hundred fifty feet of the nearest right-of-way line of an intersecting street for major collectors and 185 feet for minor arterials (see section 3.2.4).

B. Unless otherwise approved by City Engineer, access shall be limited to one driveway for each tract of property separately owned. Properties contiguous to each other and owned by, or previously owned by, the same party are considered to be one tract.

C. Driveways giving direct access may be denied if alternate access is available.

D. When necessary for the safe and efficient movement of traffic, access points may be required to be designed for right turns in and out only and will include appropriate deceleration and turning lanes.

E. When approved, or directed by the City Engineer, a driveway access design may be a "street type intersection" with curb returns.

3.9.2 TRAFFIC IMPACT STUDIES. A Traffic Impact Study, (TIS) is a specialized study of the impacts that a certain type and size of development will have on the surrounding transportation system. It is specifically concerned with the generation, distribution, and assignment of traffic to and from the “new development”. The term “new development” also includes properties that are being redeveloped.

A TIS shall be required for all new developments or additions to existing developments which generate 100 or more trips during the morning or afternoon peak hours or which will have a significant impact on the City’s transportation system as determined by the City Engineer. Traffic Impact Studies are divided into three categories. The scale of development will determine which category of study will be required. Each category differs by specific analysis requirements for the study and the study’s level of detail. Below is a description of each category.

CATEGORY I -- Developments which generate 100 or more new peak hour trips, but less than 500 trips during the morning or afternoon peak hours. Peak hour trips will be determined by ITE's Trip Generation Manual.

In addition to the above threshold requirements, a Category I TIS may also be required by the City Engineer for any specific traffic problems or concerns such as:

- proposed or existing offset intersections;
- situation with a high number of traffic accidents;
- driveway conflicts with adjacent developments;
- nearby intersections that have reached their capacity;
- proposed property rezones when there is a significant potential increase in traffic volumes;
- when the original TIS is more than two years old, or where the proposed traffic volumes in the original TIS increase by more than twenty percent (20%).

For a Category I TIS, the study horizon shall be limited to the opening year of the full build-out of the development.

The minimum study area shall include site access drives, affected signalized intersections and major unsignalized street intersections.

CATEGORY II -- Developments which generate from 500 to 1,000 new peak hour trips during the morning or afternoon peak hours.

The study horizon shall be for the year of completion for each phase of the development, the year of its completion and five years after the development's completion.

The minimum study area shall include the site access drives and all signalized intersections and major unsignalized street intersections within one-half mile of the development.

CATEGORY III -- Developments which generate above 1,000 new peak hour trips during the morning or afternoon peak hours.

The study horizon shall be for the year of completion for each phase of the development, the year of its completion, five years after the development's completion, and ten years after the development's completion.

The minimum study area shall include the site access drives and all signalized intersections and major unsignalized street intersections within one-half mile of the development.

The City Engineer, or his designated representative, shall make the final decision of requiring a TIS and determining whether the study falls within Category I, II, or III.

The TIS shall be conducted and prepared by the Traffic Engineer. The subject Engineer shall have special training and experience in traffic engineering and be a member of the Institute of Transportation Engineers (ITE).

Generally, the data necessary for such a study will require a description of the study area, the scope of development, turning movement traffic counts, accident analyses, roadway geometry, traffic control devices, and trips generated by the new development. The roadways and intersections within the study area shall be analyzed with and without the proposed development to identify and projected impacts with regard to level of service and safety.

Where the highway will operate a Level of Service 'C' or better without the development, the traffic impact of the development on the roadways, and intersections within the study area shall be mitigated to Level of Service 'C'. Mitigation to Level of Service 'D' may be acceptable with the concurrence of the City. A list of mitigation improvements will be provided in the study to achieve this Level of Service.

The guidelines and specific requirements for the preparation of a TIS are found in the "City of St. George Traffic Impact Study Guidelines". All studies prepared for submittal to the City shall follow these guidelines unless otherwise approved.

3.10 SURVEY MONUMENTATION STANDARDS. This sub-section sets forth the general standards for survey monuments.

3.10.1 GENERAL REQUIREMENTS. Only a Land Surveyor, registered in the State of Utah, shall be authorized to determine or establish the exact location for a survey monument. Only such registered Land Surveyor shall be authorized to perpetuate and reference existing Class I and II survey monuments located within the limits of public or private streets.

3.10.2 MONUMENTS. Class I or II monuments shall be set in accordance with the recorded maps so that the survey, or any part thereof, may be readily retraced. Such monuments shall be set at:

- A. All angle points in survey boundary (Class II).
- B. All angle points of tangency and points of curvature on and along survey boundary (Class II).
- C. All street centerline intersections Class I).

- D. At a P.I. outside of right-of-way (Class II). If the P.I. falls outside the limits of pavement then P.C.'s and P.T.'s shall be monumented with Class I. If the P.I. falls inside the pavement area then a Class I monument is required and no monumentation required for P.C.'s and P.T.'s.
- E. All intersections of street centerlines at survey boundary (Class II).
- F. 600-foot intervals, unless otherwise approved. If line of sight is not obtainable within a 600-foot interval, then monuments will be required to be closer together unless otherwise approved by the City Surveyor.

All the above established points which fall within the limits of public or private rights-of-way shall be referenced with four permanently established reference points within a radius of twenty (20) feet to one hundred (100) feet all of which shall be outside the pavement area. The angle from tie to tie shall be as near ninety degrees as possible, radiating from the established intersection points. A copy of the survey notes documenting the setting of the reference ties shall be kept by the responsible surveyor and a copy shall be delivered to the office of the City Surveyor and of the County Surveyor's depository.

When a section corner, quarter corner or sixteenth corner falls within a fully improved roadway and must be set, or reset, the responsible surveyor shall contact the County and City Surveyor for directions and/or requirements.

All monuments shall have brass marker or aluminum cap in accordance with the standard drawings. The surveyor's registration or license number shall be stamped on the cap.

Monuments must be set prior to the final acceptance of the improvements.

Where hard rock or other physical obstructions are encountered, monument length sufficient to resist removal may vary within reasonable limits.

All monuments shall be set in such a manner that the accuracy of their relative positions is not less than second-order Class II, in accordance with the specifications established by the U.S. Federal Geodetic Control Committee. When monuments are being reset, the initial order used in the setting shall be used, but in no event shall it be less than second-order Class II.

3.10.3 TYPES OF MONUMENTS. Class I and II monuments shall be installed in accordance with City requirements.

SECTION 4

CONSTRUCTION STANDARDS

4.1 INTRODUCTION. This section sets forth the requirements for earthwork, pipeline construction, roadway construction, chip seals, slurry seals, concrete work and restoration of surface improvements.

4.2 SURVEY REQUIREMENTS. Prior to commencing the work, all construction shall have appropriate construction staking in conformance with the approved drawings unless otherwise approved by the City Engineer. The staking shall have all necessary information including, but not limited to, stationing, cut or fill data, off-set distance and invert elevations. The information shall be placed on the face of stakes in a legible manner using weatherproof marking materials and shall be in accordance with general surveying practice. All construction staking shall be under the direction of the Engineer responsible for the project.

When a water main design has a profile with grades, a grade line will be staked at the designated grades prior to installation of any pipe. A laser may be used in lieu of a grade line. All sewer lines and storm drains will require that a grade line be set and checked prior to installation of any pipe.

4.3 EARTHWORK. This subsection defines the requirements for excavation and backfill for structures, preparation of embankments and fills, and subgrade preparation for pavement and other surface improvements.

4.3.1 MATERIALS. Earthwork materials shall conform to the following:

4.3.1.1 EXCAVATION. All structures shall be founded on prepared original soil or engineered fill. Unauthorized excavation below the specified structure subgrade shall be replaced with concrete, untreated base course, or approved engineering fill thoroughly compacted to a minimum of ninety five percent (95%) of maximum dry density. Subgrade soil for all concrete structures, regardless of type or location, shall be firm and thoroughly compacted to a minimum of ninety-five percent (95%) of maximum dry density for granular soils or ninety percent (90%) of maximum dry density for silty/clay (fine-grained) soils.

4.3.1.2 SUBSOIL REINFORCEMENT. Coarse gravel, crushed stone, or a geotextile may be used for subsoil reinforcement when approved by the City Engineer. Coarse gravel or crushed stone shall be applied in six (6) inch layers, each layer being embedded in the subsoil by thorough tamping. Approved geotextile shall be installed in accordance with manufacturers recommendations. All excess soil shall be removed. The finished elevation of any subsoil shall not be above the specified sub-grade elevation.

4.3.1.3 BACKFILL. Backfill shall be placed to the lines and grades shown on the approved drawings, or as directed by the City's Representative. Prior to

backfilling any construction work, the excavation shall be cleaned of all forms, trash and debris, and such material shall be removed from the site. Backfill material shall be approved and consist of excavated material or clean imported materials such as sand, gravel or other suitable material.

Backfill shall be placed in layers compatible with the equipment and not exceeding six (6) inches in compacted thickness. Each layer shall be compacted to a minimum density of ninety-five percent (95%) of maximum dry density for granular soils or ninety percent (90%) of maximum dry density for silty/clay (fine-grained) soils.

4.3.2 CONSTRUCTION METHODS. The methods employed in performing the work shall be the responsibility of the Contractor. These methods shall include, but are not limited to, the following.

4.3.2.1 CONSTRUCTION OF EMBANKMENTS. Unsuitable materials that occur in the foundations for embankments shall be removed by clearing, stripping and/or grubbing. When required by the City Engineer, the embankment and the materials used shall be approved by a Geotechnical Engineer. All materials in embankments shall be placed, moistened, and compacted as outlined in the following paragraphs.

When the material needed for embankment exceeds the amount of material available from excavation, sufficient additional materials shall be provided by the Contractor. All materials used for embankment construction shall be free from deleterious materials and rocks larger than three inches in diameter and all other material unsuitable for construction of embankments. Rocks larger than three inches may be used when recommended by the Geotechnical Engineer and approved by the City Engineer.

Grading of completed embankments shall bring the surfaces to a smooth, uniform condition with final grades being within 0.1 foot of the design grade. Cut and fill slopes shall be a 2 horizontal to 1 vertical maximum (2h:1v). Construction of slopes steeper than 2h:1v or fills in excess of five feet, or when placement is on a slope of greater than 5h:1v, shall be reviewed and recommended by the Engineer.

4.3.2.2 COMPACTION OF EARTH MATERIALS. The fill material shall be deposited in horizontal layers having a thickness of not more than eight (8) inches and then compacted to the density as herein specified. Moisture content during compaction operations shall be within two percent (2%) of optimum for granular soils and shall be two to five above (2%-%5) optimum for fine-grained soils unless otherwise directed by the Geotechnical Engineer. The moisture content shall be uniform throughout the layers.

If the moisture content is greater than specified for compaction, the compaction operations shall be delayed until such time as the material has dried to the specified moisture content. When the material has been conditioned as herein - specified, the backfill or embankment shall be compacted as directed below.

Under roadways, curb and gutter, sidewalks and driveways, and extending one foot beyond the proposed construction (or to a distance equal to the depth of the embankment material, whichever is greater), the embankment material shall be compacted to a density equal to not less than ninety five percent (95%) for granular soils and ninety (90%) percent for fine-grained soils. Other fills and embankments not noted above shall be compacted to ninety (90) percent maximum dry density. When compaction cannot be met with native or imported materials, a sand slurry mix (no gravel) may be used in lieu of compacted materials for backfill which is above the six to eight (6-8) inch zone above the pipe.

Exposed natural soils within construction areas, beneath walkways, slabs and pavement shall be scarified to a depth of twelve (12) inches, moisture conditioned, and compacted to the specified density. Where rock or other acceptable material is exposed, scarification may not be necessary.

Foundations for structures shall be uniform throughout and shall not be placed partially on undisturbed soil or compacted fill and partially on cemented deposits or rock.

Foundation soils should not be allowed to become saturated during construction.

4.3.2.3 SUBGRADE PREPARATION. As a minimum, the original soils under roadways, curb and gutter, sidewalks, and driveways shall be scarified to a depth of one foot prior to compaction operations. All scarified soils shall be compacted to the equivalent of ninety five percent (95%) of maximum dry density for granular soils or ninety percent (90%) of maximum dry density for fine grain soils. Additional overexcavation and recompaction of original soils due to poor subgrade conditions may be required. Subgrades shall be shaped and graded to the design grade. Drainage shall be maintained at all times. Subgrades shall be stabilized and compacted as directed. When springs or underground water is encountered during construction the Engineer and the City's Representative shall be notified immediately. Work shall not proceed until an acceptable mitigation plan is approved. Ground water discovered during construction shall not be ignored!

The subgrade preparation requirements listed above are considered to be the minimum. When required, the subgrade shall be overexcavated and the material removed from the site. Select borrow material may be imported, placed and compacted as directed by the City's Representative.

To demonstrate the stability and compaction of the subgrade, the Contractor may be required to proof-roll the subgrade prior to placing any base gravel. The subgrade shall be proof-rolled with at least one pass coverage with a roller with pneumatic tires or other acceptable equipment of at least ten-ton capacity. All proof-rolling shall be accomplished in the presence of the City's Representative. Ground contact pressure for all tires shall be 85 to 90 psi unless otherwise recommended. When the proof-rolling shows an area to be unstable, it shall be brought to satisfactory stability by additional compaction, reworking, or removal of unsuitable material and replacement with acceptable material.

4.3.2.4 CONSTRUCTION OF NON-STRUCTURAL FILLS. Fills shall be placed to the lines and grades shown on the approved drawings and shall include all areas not specifically designated for support of structures, roads, utilities, easements, drainage ways, etc. (such as landscape areas, open space areas, etc.). Fill material shall generally be compacted to a minimum of ninety percent (90%) of maximum density and shall consist of material that can be compacted to prevent settlement such as soil, rocks, blocks, crushed stone, broken concrete, etc. Fill material shall not include broken asphalt, toxic or hazardous materials waste sludge, deleterious materials such as muck, ash, sod, grass, trash, tree stumps, lumber, dead animals, etc.

4.3.3 QUALITY CONTROL. All earthwork shall be performed in accordance with these standards and shall be tested and accepted as follows:

4.3.3.1 TESTING. Minimum testing of earthwork shall be as follows:

- Soil Classification - One per material source. Soil classifications shall be in accordance with AASHTO M-145. For determination of granular soils or fine grained soils use ASTM D-2487 (Unified Soil Classification System). The sieve analysis shall be according to ASTM C-136 and C-117.

- Soil Proctor - One determination for each significant change in soil type as necessary to provide required compaction testing. Tests shall be ASTM D-1557 method A or D (modified proctor).

- Earth fill moisture/
Density
determination - One test per five hundred (500) cubic yards of fill placed in an embankment. Tests shall be ASTM D-1556 or D-2922 and D-3017.

- Subgrade moisture/
density
determination - One test per seven hundred fifty (750) square yards of surface area. Tests shall be ASTM D- 1556 or D-2922 and D-3017. Additional moisture density determinations may be made when required by the City's Representative.

4.3.3.2 ACCEPTANCE. Any earthwork determined not to be in compliance with these standards shall be removed and replaced or reworked until compliance is obtained. Costs for the rework or testing the rework shall be paid for by the Contractor.

4.3.4 SPECIAL REQUIREMENTS. The requirements outlined in this section are only a minimum. When a geotechnical investigation is required, the recommendations of the geotechnical report shall be followed unless said recommendations are less than minimum standards.

All development projects shall submit a final soils engineering and engineering geology report in accordance with Uniform Building Code, 1994 Edition, Appendix Chapter 33, or as subsequently modified.

4.4 PIPELINE CONSTRUCTION. This subsection covers the requirements for materials, trenching, placing, backfilling, cleaning, testing and other miscellaneous requirements for underground pipeline construction and associated work. This section incorporates the requirements of the AWWA Standards and the Manufacturer's Recommended Installation Procedures, whichever is more stringent.

4.4.1 MATERIALS. This subsection specifies the acceptable materials for pipeline construction for use in sanitary sewers, underground culverts, storm drains, water pipes, and appurtenant construction. All materials shall be new and conform to the requirements for class, brand, size and material as specified herein. All materials shall be stored and handled in accordance with manufacturers recommendations.

4.4.1.1 SEWER PIPE AND FITTINGS. SEE ASH CREEK SPECIAL SERVICE DISTRICT.

4.4.1.2 STORM DRAIN PIPE. Pipe listed under Sections 4.4.1.1 A, C, and D. "Sewer Pipes" of these standards, as well as the following pipes, may be used in the construction of storm drain lines and culverts.

A. CORRUGATED POLYETHYLENE PIPE. Corrugated polyethylene pipe shall be high density polyethylene corrugated exterior with a smooth interior wall. Eight to ten (8-10) inch diameter shall meet the requirements of AASHTO M-252 and have a smooth interior liner. Twelve to thirty six (12-36) inch diameters shall conform to AASHTO M-294 Type S. Forty-two to forty-eight (42-48) inch diameter shall conform to AASHTO MP-6 type. Materials shall conform to ASTM D-3350. All pipe joints and fittings shall be water tight and conform to AASHTO M-353 or M-294, and shall be approved by the City's Representative.

B. CORRUGATED ALUMINUM PIPE. Corrugated aluminum alloy pipe shall conform to AASHTO designation M-196. Any aluminum alloy to be in contact with concrete shall first be spray or brush coated to a

minimum thickness of 0.05 inch with an asphalt-fiber compound conforming to the requirements of Section 702 of the State of Utah Standard Specifications for Road and Bridge Construction. The aluminum alloy shall be thoroughly cleaned, including the removal of oil and grease, and shall be dry prior to treatment. Pipe installation and appurtenances shall conform to UDOT Standard Specifications, 1992.

C. CORRUGATED STEEL PIPE. Use of corrugated steel pipe shall require pre-approval from the City Engineer and shall be on a case-by-case basis.

Corrugated steel pipe shall be in conformance with AASHTO M-36 and other applicable AASHTO standards as required. Smooth flow spiral rib pipe shall generally be used in storm drain applications while other applications may require annular or helical corrugations. Pipes shall be fabricated with a continuous lock seam or ultra high-frequency resistance welded seams.

(1) **COATINGS.** All pipe shall have an aluminized coating, both sides, in accordance with AASHTO M-274 specifications unless otherwise approved. The pipe shall be fabricated from steel coils that have been hot-dipped coated in a bath of commercially pure aluminum. This coating shall be uniform throughout on both sides of the sheet and be metallurgically bonded between the metals.

When a polymer coating is approved for use, such coating shall be a minimum of 10 mils in thickness and shall be a two-sided coating and shall conform to AASHTO M-245

When a galvanized coating is approved for use, such coating shall be hot dipped in accordance with AASHTO M-245. The coating shall be on both sides.

Other coatings and linings may be approved.

(2) **JOINTS.** All joints shall have the same base metal and coating as the pipe being joined. Joints shall provide circumferential and longitudinal strength to preserve the pipe alignment, to prevent separation of the pipe, to prevent infiltration of fill material and to provide water tight joints. O-ring gaskets or other acceptable material shall be used.

(3) **FITTINGS AND ACCESSORIES.** All fittings, bolts and accessories shall meet applicable specifications of the pipe being used. Use accessories and gaskets recommended by the manufacturer.

(4) **INSTALLATION.** Installation shall be in accordance with the manufacturer's recommendations and these specifications.

NOTE: Use of this pipe may require significant testing and evaluation to determine compatibility with the ground and the intended installation. Soil Ph, resistibility and other necessary determinations should be made to ensure compatibility.

4.4.1.3 SEWER MANHOLES. SEE ASH CREEK SPECIAL SERVICE DISTRICT.

4.4.1.4 WATER PIPE AND FITTINGS. The materials used for pipe and fittings shall all be new and conform to the requirements for class, brand, size and material as specified.

A copy of the manufacturer's installation recommendation for each type of pipe shall be provided for each construction job and shall be available on the jobsite at all times. These recommendations shall be followed during construction unless instructed otherwise by the City's Representative. All pipe materials are as outlined below.

A. GENERAL PIPE REQUIREMENTS. Pipe materials shall conform to the following requirements.

SIZE	TYPE
3/4" to 1"	Polyethylene Pipe IPS Size
1 1/2" - 2"	Black or Blue Poly (HDPE) Copper Tube Size
Over 2"	Ductile Iron Class 51 with poly jacket sock <u>or</u> PVC C-900, Class 150 (sand bedded) see note #1 below. Ultra-Blue PVC (mo) Pressure Pipe C-909PC150

Note:

1. High density polyethylene pipe may be used upon approval of the Water Department.
2. For pipes greater than 12 inches, material type will be determined by the Water Department. When the pipe is to be installed in a rocky area, the pipe material will be ductile iron.

All pipe shall conform to the current AWWA standards for each class of pipe listed above.

B. CONNECTING WATER METERS. Only authorized employees of the Water Department shall be allowed to connect or disconnect water meters. All boxes set in concrete shall be flanged to prevent settlement.

C. DUCTILE IRON PIPE. All ductile iron pipe shall be Class 51 conforming to the latest edition of AWWA Specifications C-151 (ANSI A21.51).

C.1 JOINTS. Ductile Iron Pipe shall be either Mechanical Joints, Rubber Gasket Slip-on Joints, Flanged Joints, or a combination of the above as specified on the plans. Pipe shall also conform to all current AWWA standards.

C.2 POLYETHYLENE WRAPPING. A polyethylene wrap shall be required on all ductile iron pipe. The polyethylene wrap tubing shall be cut to provide for a minimum of one foot of lap over both the adjoining pipes. The ends of the tubing shall be wrapped using three circumferential turns of plastic adhesive tape. The loose wrap on the barrel shall be pulled snugly around the barrel of the pipe and the excess folded over at the top. This fold shall be held in place by means of six-inch-long strips of plastic tape placed at intervals of three feet along the pipe barrel.

Bends, reducers, offsets and restraint gland locations shall be wrapped in the same manner as the pipe. Valves shall be wrapped by bringing the tube wrap on the adjacent pipe over the bells of the valve and sealing with adhesive tape. The valve bodies shall then be wrapped with flat sheets passed under the valve bottom and brought up around the body to the stem and fastened with the tape.

C.3 POLYETHYLENE WRAPPING. A polyethylene wrapping shall be required on all metal or iron fittings, hydrants, valves and joint restraints.

D. ULTRA BLUE. All ultra blue PVC (mo) pressure pipe shall meet the latest AWWA Standards C-909.

E. PVC PIPE. All PVC Pipe used shall meet the latest AWWA standards C-900 and C-905. HDPE pipe shall meet the latest AWWA standards C-901 and C-906.

F. COPPER PIPE. Where service lines are two (2) inch or less in diameter, type K copper pipe may be allowed with prior approval of the City Water Department. Pipe which has outside dimensions greater than two (2) inches in diameter shall not be copper. All copper pipe shall conform to the current AWWA standards.

G. PIPE FITTINGS. (Two inches through 30 inches) flanged and mechanical joint fittings shall be ductile iron class 250, and shall be produced in accordance with ANSI/AWWA C-110/A 21.10 and

ANSI/AWWA C-111/A21.11 and shall conform to details and dimensions published therein. Fittings are cement lined and seal coated in accordance with ANSI/AWWA C-104/A21.04. The fittings will be manufactured by Tyler or approved equal.

For large tapplings (6 inch and greater) tapped into PVC or ductile iron pipe, the following tapping sleeves are approved for pressures less than 125 psi:

Romac Style fts 419, fts 420
Power Seal (5 bolt), model 3480
Romac 305 Stainless Steel Service Saddle

For pressures greater than 125 psi, a mechanical joint sleeve type will be required. The following are approved for use.

Mueller H-615
5-149-DI
Clow F-5205
Power Seal Model 3490
Romac SST-III with ductile flange rated at 200 psi
Ford FTSS

For larger diameter pipe:

FTS-425 Class D
For HDPE - Romac SST-H

H. TAPPING MATERIAL SPECIFICATION. For small tapplings (three quarter (3/4) inch through two (2) inch) tapped into cast iron, steel, PVC, or ductile iron pipe, the following materials shall be required:

H.1 SADDLE CASTINGS. Large saddle tapplings shall be stainless steel or bronze single/double strap.

H.2 STAINLESS STEEL STRAP. The stainless-steel strap shall consist of a two (2) inch wide strap and shall come complete with sufficient stainless steel or bronze bolts, nuts and washers (with five-eighths [5/8] inch N.C. Teflon coated roll threads) to properly clamp the strap to the pipe. M.I.G. welds shall be pasivated for resistance to corrosion.

H.3 GASKETS. Gaskets shall be made from virgin SBR compounded for water services

I. REPAIR CLAMPS. All repair clamps shall be stainless steel and be equal to the following approved brands:

Romac SS1-552
Power Seal 3121AS, 3122 AS

For HDPE

Romac Style SS1-H, SS2-H

J. VALVES AND BOXES. Unless otherwise specified by the Water Department, all valves, ten (10) inches and smaller, shall be of a resilient-seat-gate-valve type, and all valves over ten (10) inches shall be butterfly valves; except for a ten (10) inch "hot tap".

J.1 GATE AND BUTTERFLY VALVES. Valves shall conform to the latest revision of AWWA valve standards. All valves shall be Mueller, Kennedy, Clow, or Pratt. Exceptions to this will require the City Water Department Engineer's approval.

All valves, ten (10) inches and less, installed next to a fitting must be flange x mechanical joint (MJ) and installed with the flange end connecting to the tee, cross, or fitting and megaluged to the line unless otherwise approved by the Water Department. Valves greater than twelve inches shall have flange x flange with an MJ adaptor in order to flange to tee, cross, or fitting and shall be megaluged to line.

All six- and eight-inch valves shall have a 16"x16"x4" slab of concrete placed under them for support. Valves ten inches and greater shall have a 20"x20"x4" concrete slab placed under them for support. All support slabs shall be tied to the valves.

All setter shut off valves shall be provided with bronze handles.

J.2 VALVE BOXES. All valves shall be provided with a cast iron valve box of the extension sleeve type or a screw type adjustable, and the height shall be adjusted to bring the top of the valve box flush with the finished surface. Extension sleeve shall be drilled or slotted and the marking wire shall be threaded through. The valve box shall not be less than five inches in diameter and shall have a minimum wall thickness of .375 inch. The box shall be provided with a suitable base and cover. The word "WATER" shall be cast on the cover.

Valve boxes shall be installed plumb and properly positioned to allow access of the operating wrench. To ensure that the box is not displaced during backfill operations, the backfill shall be hand mechanically tamped for a distance of five feet each way along the trench. All valve boxes shall include a concrete collar in accordance with the standard drawings with flow indication arrows.

K. WATER SERVICE LATERALS. The material used for water service connections shall comply with the following requirements.

K.1 SERVICE PIPE. Service pipe shall be copper or polyethylene.

Note: When polyethylene pipe is used, only Instatite fittings shall be used.

K.2 CORPORATION STOPS. Corporation stops shall be as manufactured by the Mueller Company, or Ford or approval equal, and shall conform to the several designations shown below for the various sizes.

	WATER SERVICE CONNECTION SIZE			
	3/4"	1"	1-1/2"	2"
MUELLER CO.	H-1500	H-1500	H-1510	H-1501
FORD	F600	F600	F6125	F6125

All services shall have a flare or compression type joint for the service pipe and shall be threaded on the inlet end with an AWWA corporation stop thread.

K.3 METER SETTER YOKES. Meter setters or meter yokes shall have a built-in backflow prevention device and shall have a corrosion-resistant bronze body, dual acetyl plastic valves with natural rubber gaskets that are independently acting and capable of giving two levels of protection; stainless steel springs; a resilient O-ring end-tap seal; and full port inlet angle ball valve with brass handle. All internal parts shall be accessible without removing the valve from the line. Meters shall be installed by Water Department personnel only.

K.4 METER BOX AND LID. The meter boxes shall be high density polyethylene (HDPE) “Brooks” design or equal. Size shall be as follows unless otherwise approved by City’s Representative.

PIPE SIZE	METER BOX SIZE
3/4"	17" x 11 3/4" #1419-18
1"	25" x 16" #1324-18
1 1/2" - 2"	32" x 19" #1730-18

The meter box lids shall have a hinged opening for meter reading. Lid marking shall be approved by the Water Department. A concrete collar shall be installed around the meter box in accordance with standard drawings. All meter boxes shall be placed behind sidewalks in accordance with standard drawings unless otherwise directed by City's Representative.

Any meter box covered, or damaged, during construction operations shall be uncovered, replaced, and raised to finish grade by the Contractor. In areas without sidewalks, meter boxes shall be flush, or one inch above the finish grade.

K.5 SERVICE CONNECTIONS. At all points designated by the Water Department, service connections shall be installed and shall extend from the property line to the building, unless otherwise directed by the Water Department.

Individual water services shall be one inch for dual services and three quarter (3/4) inch for a single service from the water main to the meter setter for normal domestic service. When directed by the Water Department, the water service shall be one and one half (1 1/2) or two inches in diameter. Services shall have a minimum of three (3) feet of cover and be constructed as shown in the standard drawings. For service laterals two inches in diameter and smaller, service saddles shall not be closer than twelve inches (12) from the end of the main, nor closer than eighteen (18) inches to any other service saddle or pipe joint.

A mechanical joint type tapping sleeve shall be used on all "hot taps" where the line pressure is greater than one hundred twenty five (125) psi. The approved mechanical joint sleeves and type shall be as shown in the standard drawings.

L. MARKING WIRE. Marking wire shall be installed on all waterline installations unless otherwise approved by the Water Department. Marking wire shall conform to the following:

L.1 Marking wire shall be spliced together with “grease” nuts, or equal. Prior to installation of the wire nut, a minimum amount of wire shall be bared and twisted together with pliers to assure good contact.

L.2 Marking wire should be taped and pulled tight along the top of the pipe to ensure against breakage.

L.3 Marking wire shall extend up to all hydrants and valves. At valve clusters marking wire shall be run to all valves. The wire should be pig tailed, not looped.

L.4 Marking wire shall extend out of the valve box four (4) to six (6) inches.

L.5 It is the Contractor's responsibility to guarantee and show that the marking wire performs satisfactorily for its intended use. It is recommended that the contractor test the performance of the wire prior to installation of surface improvements.

L.6 After all the boxes are raised and prior to placing concrete collars, the Contractor shall notify the Water Department to perform the final acceptance testing.

M. FIRE HYDRANTS. Fire hydrants shall be a three-nozzle, five and one-half inch (5½) diameter Mueller, Modern Centurion, Model A-423; Kennedy, Model K-81A; or approved equal, with foot valve and six (6) inch mechanical joint connection. Fire hydrants shall conform to the latest edition of AWWA C-502, "Dry Barrel Fire Hydrants." All hydrants shall be designed for a working pressure of two hundred (200) psi and a hydrostatic pressure of three hundred fifty (350) psi. Hydrants shall be furnished with a paint finish above the ground line identical in color to the existing hydrant paint (red).

Hydrants shall be installed with a shut-off valve at the mainline. If the hydrant lateral is greater than two hundred (200) feet long, a second valve shall be installed at a location determined by the Water Department.

After the hydrant is installed and accepted, it will be the responsibility of the Water Department to maintain the hydrant. Where applicable, the customer/property owner will allow the Water Department access for said maintenance.

Dead-end mains shall not be installed without prior approval of the Water Department. If installed they shall not exceed six hundred (600) feet in length. Hydrants shall be located at the end of dead-end mains for flushing purposes as well as for fire protection. Washout valves, in lieu of fire hydrants, are not allowed without prior approval of the Water Department.

Hydrants shall be of a flanged joint type or mechanical joint inlet. All hydrants shall be so designed as to allow the flanges at sidewalk level to separate without material damage to the main barrel section when struck by a large object, such as a vehicle. Upon such damage, the main gate valve must remain closed to avoid flooding or washout. Hydrants with a nominal five-inch valve opening shall be furnished with two nominal two and one half (2½) inch National Standard Thread Hose Nozzles and one nominal four and one half (4½) inch National Standard Thread Pumper Nozzle. All nozzles shall be furnished with a cap and gasket with attaching chain. All hydrants shall open counter clockwise with a pentagon operating nut conforming in size to the specifications of the Water Department.

Fire hydrants shall be set to provide at least the minimum pipe cover for the branch supply line. Nozzles shall be at least eighteen (18) inches above finish grade. Each hydrant shall be set on a concrete foundation at least eighteen (18) inches square and four (4) inches thick. Each hydrant shall be blocked against the end of the trench with concrete. Hydrant drainage shall be provided by installing gravel or crushed rock (¾" to 2" washed gravel) around the hydrant, and below the top of the hydrant supply line. One third (1/3) cubic yard of one and one half (1½) inch gravel shall be placed around the drain holes just above the hydrant valve casing. All hydrants shall stand plumb. The hydrant pumper nozzles shall face the street and be perpendicular to the curb line. The hose nozzle shall be parallel to the street. Hydrants shall be located inside the street utility easements or as otherwise directed by the Water Department.

N. FLOWABLE BACKFILL. Flowable backfill material for water main trenches shall be sand slurry with in-place relative density greater than ninety five percent (95%).

O. PRESSURE REDUCING VALVES. Pressure reducing valve installation will be constructed as per the detail shown in the standard drawings. The valves will be as manufactured by Singer and approved by the Water and Power Engineer.

P. MEGALUG SYSTEM. A megalug retainer gland system shall be used on all mechanical joints and shall meet UNI-B-13 for PVC and be UL/FM approved through twelve (12) inch diameter for both ductile iron and PVC pipe.

A megalug retainer gland system shall be used on all mechanical joints and shall meet Uni-B-13 for PVC and be UL/FM approved through twelve (12) inch diameter for both ductile iron and PVC pipe. The restraint mechanism shall consist of individually activated gripping surfaces to maximize restraint capability. Twist-off nuts, sized the same as the tee-head bolts, shall be used to ensure proper activating of restraining devices. The gland shall be manufactured of ductile iron conforming to ASTM A-536-80. The retainer-gland shall have a pressure rating equal to that of the pipe on which it is used (through fourteen inches) with a minimum safety factor of 2:1. Gland shall be Megalug by EBAA Iron, Inc. or approved equal. The type and model of retainer and amount for each connector is shown on standard drawings.

As an alternate to the megalug system, Ford Uniflange Series 1400 retainer glands and Series 1300 and 1390 joint restraints will be used. For PVC, Ford Uniflange Service 1500 retainer gland will be used. These materials listed are approved for use on the City of Toquerville Water System.

4.4.2 CONSTRUCTION METHODS. This subsection covers the requirements for trenching, placing, and back filling of all underground pipelines (sewer, water, storm drains, etc.). The methods employed in performing the work shall be the responsibility of the Contractor. The Contractor shall make such changes in the methods used as are necessary to install an acceptable finished product. The methods shall include, but are not limited to the following:

4.4.2.1 CONTROL OF GROUND WATER. All trenches shall be kept free from water during excavation, fine grading, pipe laying, jointing, and embedding operations. Where the trench bottom is mucky or otherwise unstable because of the presence of ground water, and in cases where the static ground water elevation is above the bottom of any trench or bell hole excavation, such ground water shall be lowered and controlled to the extent necessary to keep the trench free from water and the trench bottom stable when the work within the trench is in progress. Surface water shall be prevented from entering the trenches.

Dewatering for pipeline construction shall commence when groundwater is first encountered and shall continue until such time as water can be allowed to rise. Requirements of section 4.3.2.2 shall be complied with when groundwater is encountered. Dewatering shall be conducted such that no pipelines are placed in water nor shall water be allowed to rise over the pipe until the pipeline has been

pressure tested and any concrete or mortar has achieved final set. Water shall not be allowed to rise in pipeline trenches or drained excavations until pipelines are backfilled or restrained to prevent flotation.

4.4.2.2 EXCAVATION FOR PIPELINES. Trench excavation shall include all operations necessary for excavation of all materials of whatever nature in relation to pipeline installation. All excavation, including the manner of support and provisions for access to trenches, shall comply with all current regulations as determined by OSHA. Trenches shall be excavated to the lines and grade shown on the drawings, and to a depth to provide the minimum required cover of three (3) feet over the pipe unless otherwise approved by the Water Department. Pipe installation shall be in accordance with the pipe manufacturer's recommendations. The bottom two feet of the trench should have vertical walls. All finish grading necessary for preparation of the trench bottom shall be made manually. Over-excavating shall not be allowed without re-compaction of backfill in accordance with these standards.

Excavation for trenches in rock shall extend to a depth of at least twelve inches below the bottom of the pipe. Bedding material as outlined in Table 4.1 shall be placed and mechanically compacted to ninety-five percent (95%) of maximum dry density in maximum six-inch lifts to provide a smooth, well compacted and stable foundation for the pipe or appurtenant works.

Trench bottoms shall be hand-shaped as specified and the maximum width of the trench, measured at the top of the pipe, shall be as narrow as possible, but not wider than fifteen (15) inches on each side of the pipe.

Where unstable earth, mud or muck is encountered in the excavation at the grade of the pipe, the unsuitable material shall be removed to a minimum of twelve inches below grade and the subsequent hole shall be backfilled with crushed rock or gravel (as called out in Table 4.1 under "foundation material") to provide a stable subgrade. The gravel material shall be deposited over the entire trench width. The maximum layer thickness shall be six inches. Each layer shall be compacted by tamping, rolling, vibrating, spading, slicing, rodding or by a combination of one or more of these methods. In addition, the material shall be graded to produce a uniform and continuous support for the entire length of the installed pipe.

Should the Contractor elect to install the pipe by boring, or jacking, approval must first be obtained from the City's Representative. The Contractor shall furnish, place, and maintain all supports and shoring that may be required for the sides of the excavation, and all pumping, ditching, or other approved measures for the removal or exclusion of water, including, but not limited to, storm water and waste water reaching the worksite from any source so as to prevent damage to the work or adjoining property.

The maximum amount of open trench permitted in any one location shall be five hundred (500) feet, or the length necessary to accommodate the amount of pipe installed in a single day, unless otherwise approved by the City's Representative. Open trenches shall not be allowed to stay open without proper safety precautions and barricading. Trenches should not be left open over night.

In the event "foundation material" is used in backfill, or replacement of over excavated material, the Contractor shall construct dams within the drain rock bedding material at maximum intervals of six hundred (600) feet. The dams shall be constructed to the top of the pipe or the level of groundwater, whichever is greater, with Class "B" Portland Cement Concrete or other approved material and shall have a minimum thickness of six inches.

TABLE 4.1

BACKFILL MATERIAL				
SIEVE SIZE	FOUNDATION MATERIAL	BEDDING/PIPE ZONE MATERIAL UP TO 1 FT ABOVE PIPE*†	2 FT. ABOVE PIPE ZONE	FINAL BACKFILL MATERIAL
	PERCENTAGE PASSING			
12"	--	--	100	Native material which contains no sod, vegetation, rocks larger than 6" diameter, asphalt or concrete chunks, etc.
6"	--	--	90 - 100	
3"	100	--	80 - 100	
2"	90 - 100	--	70 - 100	
1"	70 - 90	--	50 - 100	
½"	51 - 75	100	30 - 100	
#4	31 - 65	50 - 100	25 - 80	
#16	16 - 40	30 - 42	16 - 50	
#200	2 - 12	9 - 25	10 - 50	

* 3/4" or 1" clean crushed gravel may be used in lieu of the above table.

† A 1' sand barrier shall surround the pipe w/ a min. of 9" bedding. When in rock, a 2' sand barrier shall surround pipe w/ a min. of 12" bedding.

4.4.2.3 SHEETING, BRACING, AND SHORING OF EXCAVATIONS. All excavations shall be sheeted, braced, and shored as required to protect the workers and existing utilities and improvements from sliding, sloughing, settling or other movement of the trench walls while the work is in progress. All such sheeting,

bracing and shoring shall comply with the requirements of the Utah State Industrial Commission. All damage resulting from lack of adequate sheeting, bracing and shoring shall be the sole responsibility of the Contractor, and the Contractor shall effect all necessary repairs or reconstruction resulting from such damage.

4.4.2.4 BLASTING. Blasting shall not be allowed except by written permit from the Fire Chief. If the permit is granted, the Contractor shall comply with all laws, ordinances, and applicable safety code requirements and regulations relative to the handling, storage, and use of explosives and protection of life and property.

In addition to the above, all requirements contained in Section 2.9, Use of Explosives, shall be followed.

4.4.2.5 PIPE LAYING AND BEDDING. Pipe will be carefully inspected in the field by the Contractor and the City's Representative before and after laying. If any cause for rejection is discovered in a pipe before or after it has been laid, it shall be removed and replaced by the Contractor.

When connections are to be made to any existing pipe, conduit, or other appurtenances, the actual elevation or position of which cannot be determined without excavation, the Contractor shall excavate for, and expose the existing improvement before laying any pipe or conduit. The City's Representative shall be given the opportunity to inspect the existing pipe or conduit before the connection is made. Adjustments in line or grade of the connecting pipe which may be necessary to accomplish the intent of the plans will be made at this time.

Pipe shall be laid up grade with the socket bell, or collar ends of the pipe up grade unless otherwise authorized by the City's Representative.

In general cases, the pipe will be laid in one direction only.

Pipe shall be laid true to line and grade, with uniform bearing under the full length of the barrel of the pipe. Suitable excavation shall be made to receive the bell or collar, which shall not bear upon the subgrade or bedding. Any pipe which is not true to alignment or shows any settlement after laying, shall be removed and re-laid to the proper grade and alignment.

A. REQUIREMENTS FOR LINE AND GRADE. All drainage pipe shall be installed to the defined line and grade within the following limits.

A.1 Variance from established grade shall be not greater than one tenth (1/10) of a foot between manholes. Variance from established line shall be not more than one half foot between manholes. Any variances approved shall not impact the system design capacity

and shall be approved by the City's Representative. Any variations shall not result in a level or reverse slope installation.

A.2 The invert elevations of each manhole and box at the inlet and outlet and distance between manholes and/or boxes shall be accurately verified by use of surveying instruments prior to pouring the floor.

A.3 On main lines, invert elevations of each manhole inlet and outlet and the distance measurements between manholes shall be verified by use of surveying instruments prior to installing precast manhole bases. For service laterals, grades may be verified by use of a carpenter's level or surveying instrument.

A.4 All sewer and drainage pipe systems shall be visually inspected for defects, displacement, proper workmanship, alignment and general compliance.

B. INSTALLATION OF PIPE. A groove shall be excavated along the bottom of the trench to receive the pipe. Bell holes shall be excavated so that only the barrel of the pipe receives bearing from the trench bottom. Large rocks (over six inches in least dimension) near the trench bottom shall be removed and the hole refilled with approved backfill in accordance with Table 4.1.

Water pipe shall not be deflected at the joint more than a maximum of three percent (3%), or three degrees, per hundred (100) feet, or as per the manufacturer's recommendation.

Sewer and drain pipe shall be laid up grade. All pipe installation shall proceed with joints closely and accurately fitted. Gaskets shall be fitted properly in place and care shall be taken in joining the pipes to avoid twisting the gaskets. Joints shall be clean and dry and a joint lubricant, as recommended by the pipe supplier, shall be applied uniformly to the mating joint surfaces to facilitate easy and positive joint closures. If adjustments to the position of a pipe length are required after being laid, the pipe shall be removed and rejoined as a new pipe. When pipe laying is not in progress, the ends of the pipe shall be closed with a tight-fitting stopper to prevent the entrance of foreign material. In addition to the above requirements, all pipe installation shall comply with the specific requirements of the pipe manufacturer.

C. SETTING OF BENDS, TEES, CROSSES AND REDUCERS. Bends, tees, crosses, and reducers shall be lowered into the trench, inspected, cleaned and joined to the pipe.

Concrete thrust blocks shall not be used as a restraining system for waterline mains or laterals without prior approval of Water Department. Reaction restraints or, when permitted by the City's Representative, thrust blocking, shall be applied at bends and tees, and at points of reduction or at fittings where changes in pipe diameter occur.

The design of concrete thrust blocking shall be as shown in the standard drawings or as directed by the Water Department. The material used for thrust blocking shall be Class C concrete. Blocking shall be placed between solid ground and the fitting to be anchored. The area of bearing on the fitting and on the ground shall in each instance be that required in the standard drawings or by the City's Representative. Unless otherwise directed by the City's Representative, the blocking shall be placed so that the pipe and fitting joints will be easily accessible for repair. Restraining joints (megalug or equal) shall also be used to prevent movement wherever thrust blocks are required.

If a megalug retainer system cannot be used, a concrete thrust block system can be substituted, if approved by the Water Department, on a case by case basis.

D. PLUGGING OF DEAD-ENDS. Standard plugs shall be inserted into the bells of all dead-end fittings. Spigot ends of fittings and plain ends of pipe shall be capped. When directed by the City's Representative, a concrete reaction or thrust block shall be provided at all plugged outlet fittings in the sizes indicated on the standard drawings or as directed by the City's Representative. The plugs and caps shall also be tied to the pipe with restraining joints. The number and size of rods shall be as specified.

E. SERVICE LINES. All service lines shall be installed in accordance with the details shown on the standard drawings.

F. PIPE TO BE KEPT CLEAN. All dirt and foreign matter shall be removed from the interior of the pipe before lowering into position in the trench. Pipe shall be kept clean by means approved by the City's Representative during and after laying.

G. JOINTING PIPE SECTIONS. The sealing surface of the pipe, the bell to be joined, and the elastomeric gaskets shall be cleaned immediately prior to assembly, and assembly shall be made as recommended by the manufacturer. When pipe laying is not in progress, the open ends of installed pipe shall be closed to prevent entrance of trench water into the line. Whenever water is excluded from the interior of the pipe, enough backfill shall be placed on the pipe to prevent floating. Any pipe that has floated shall be removed from the trench and the bedding restored. No

pipe shall be laid when the trench or weather conditions are unsuitable for proper installations as determined by the City's Representative.

H. CUTTING PIPE. The pipe shall be cut in a neat manner without damage so as to produce a smooth end at right angles to the axis of the pipe. Existing transit AC pipe shall not be cut and should be removed and replaced with ductile or PVC pipe.

I. END PREPARATION. Pipe ends shall be cut square, deburred and beveled in accordance with the pipe manufacturer's recommendations.

J. PUSH-ON JOINTS. The push-on joint shall be a single elastomeric gasketed joint which shall be assembled by positioning the elastomeric gasket in the annular groove of the bell and inserting the spigot end of the pipe into the bell. The spigot end of the pipe shall compress the gasket radially to form a positive seal. The gasket and annular groove shall be designed, sized and shaped so that the gasket will resist displacement. Care shall be taken so that only the correct elastomeric gasket, compatible with the annular groove of the bell, is used. Insertion of the elastomeric gasket in the annular groove of the bell must be in accordance with the manufacturer's recommendations.

K. MECHANICAL JOINTS. The mechanical joint shall be a bolted joint of the stuffing box type, and installation recommendations from the manufacturer shall be followed. Each joint shall consist of:

K.1 A bell provided with an exterior gland having bolt holes or slots and a socket with an annular recess for the sealing gasket and the spigot end of the pipe. On all slotted holes the bolts will be supplied with square shoulders.

K.2 A sealing gasket.

K.3 A follower gland with bolt holes matching those in the fitting.

K.4 Tee bolts and hexagonal nuts of cor-ten metal.

L. PIPE BEDDING. Pipe shall be protected from lateral displacement and possible damage resulting from impact or unbalanced loading during backfilling operations by being adequately bedded in accordance with the bedding details in the standard drawings.

Pipe bedding materials shall be deposited and compacted in layers not to exceed six (6) inches in compacted thickness. Deposition and compaction of bedding materials shall be completed simultaneously and uniformly on

both sides of the pipe. Compaction shall be accomplished with hand or mechanical compactors to the satisfaction of the City's Representative. All bedding materials shall be placed in the trench with hand tools, or other approved methods in such a manner that the bedding materials will be scattered alongside the pipe and not dropped into the trench in compact masses. Bedding materials shall conform to the requirements of Table 4.1 of these standards and shall be free from roots, sod, vegetation or other deleterious material.

In the event trench materials are not satisfactory for pipe bedding, imported bedding will be required. Imported bedding material shall be graded in accordance with Table 4.1, under "bedding material".

M. METER BOXES. All meter boxes shall be located behind the sidewalk. All meters will be provided with concrete collars. Any meter box damaged or covered during the construction operations shall be replaced and/or uncovered and raised to finish grade by the Contractor as determined by the City Representative.

4.4.2.6 BACKFILLING AND COMPACTION. Backfill shall include filling of all trenches to the original ground surface or final grading elevation as shown on the drawings, or otherwise directed by the City's Representative. Backfill shall be carefully placed around and over pipes and shall not be permitted to fall directly on a pipe from such a height, or in such a manner as to cause damage. Backfill material shall be as required by Table 4.1 or as approved by the City's Representative and shall not contain any wood, grass, roots, broken concrete, frozen soil, asphalt chunks, trash or debris of any kind that may cause unequal settlement or improper consolidation.

The backfill in all utility trenches under proposed or existing roadways, curb and gutter, sidewalks and driveways shall be compacted to the equivalent of ninety five percent (95%) of maximum dry density for granular soils or ninety percent (90%) of maximum dry density for silty/clay soils. In shoulders and other street right-of-way areas, the in-place density shall be a minimum of ninety percent (90%) of the maximum dry density.

A. INITIAL BACKFILL PROCEDURE. (Pipe Zone) Backfill of selected material, which shall conform to the requirements of Table 4.1, shall be placed carefully in eight-inch non-compacted horizontal layers and compacted to a depth of twelve inches over the top of the pipe. During compaction of the initial backfill, special care shall be taken so as to not move the pipe, either vertically or horizontally. All backfill operations shall be performed in such a manner so as to avoid any damage to the pipe, valves, laterals, etc. In the event such damage or displacement occurs, such damaged or displaced pipe shall be removed and replaced with undamaged pipe on proper grade and alignment.

B. FINAL BACKFILL PROCEDURE. The backfill above a point twelve (12) inches above the top of the pipe shall be filled in horizontal layers twelve (12) inches thick or less with materials free from roots, vegetation or other deleterious material, or rocks, stones or boulders larger than six inches in the greatest dimension. The material shall be mechanically compacted with appropriate vibrating compaction equipment. Wherever, in the opinion of the City Engineer, surface settlement is not, critical compaction may be reduced to a minimum of ninety percent (90%) of maximum dry density and the backfill shall be neatly rounded over the trench to a sufficient height to allow for settlement to grade after consolidation.

C. MECHANICAL COMPACTION OF BACKFILL. The backfill shall be thoroughly compacted by mechanical compaction.

Structural and trench backfill shall be deposited in horizontal layers and compacted by the following method in such manner that the compacted material will be homogeneous and free from lenses, pockets, streaks, and other imperfections.

The materials shall be deposited in horizontal layers across the length or width of the excavation of not more than six inches compacted thickness. The excavation and placing operations shall be such that the materials when compacted will be blended sufficiently to secure the best degree of compaction, impermeability and stability.

Prior to and during compaction operations, all backfill material shall have the required moisture content and shall be uniform throughout each layer.

If the moisture content is not optimum for compaction, the compaction operations shall be delayed until such time that the material has been brought to the required moisture content. When the material has been properly conditioned, it shall be compacted by using appropriate mechanical compaction equipment as indicated below or as otherwise approved by the City's Representative.

C.1 Vibrating rollers shall consist of a self-propelled roller with a vibrating steel drum of at least one-ton capacity. The roller shall have an effective rolling width of at least twenty four (24) inches and shall deliver a compaction force of at least seven hundred (700) pounds per square inch when vibrating.

C.2 Pneumatic rollers shall consist of a self-propelled roller with pneumatic tires arranged in a manner so as to provide a satisfactory compacting unit. The roller shall have an effective rolling width of

at least thirty (30) inches and shall give a compaction force of at least five hundred (500) pounds per inch of width of tread when fully loaded. The tires shall be uniformly inflated.

C.3 Vibrating plates shall consist of a pneumatic vibrating plate attached to the boom of a backhoe and capable of compacting an area of at least three-square feet. The plate and backhoe combination shall together be capable of exerting a compactive force of at least one thousand (1,000) pounds per square inch.

C.4 Hand compactors shall be used when hand-compacted methods are specified or required because the location of the area to be compacted does not permit the use of self-propelled mechanical compactors. Vibrating plates, "pogo-stick" tampers or other approved hand-compacting equipment shall be used.

C.5 Jetting and flooding or other water consolidation methods are not permitted.

D. FLOWABLE BACKFILLING. For trenches under pavement, sidewalk, curb and gutter, and in all existing City streets, flowable backfill may be used (unless otherwise directed by the City's Representative) for backfill and shall be in conformance with the standards for "Flowable Fill" as described below. Flowable fill shall not be used as backfill for water main trenches without prior approval of the City's Representative. Flowable fill shall be discharged from the ready mix truck by reasonable means into the trench to be filled. The fill shall be brought to an elevation equal to the bottom of the road base and shall be finished level to provide a uniform surface. Flowable fill shall not take the place of roadbase or asphalt in the roadway section.

When surface restoration cannot take place promptly in existing City streets or in other areas where safety is a concern, the flowable fill may be extended to the bottom of the surface course and a temporary driving surface installed. When the permanent surface is installed the temporary surface and flowable fill shall be removed to the level of the bottom of the roadbase and the roadway structure properly restored in accordance with these standards.

Flowable fill:

D.1 Portland Cement - Type II or V.

D.2 Fly Ash - ASTM C-618, Class F, except loss on ignition shall not exceed three percent (3%) maximum, and shall come from a source approved by the City Engineer.

D.3 The coarse and fine aggregate for flowable fill shall be natural material and consisting of mineral aggregate particles meeting the following requirements.

<u>Sieve Size</u>	<u>Percent Passing</u>
3/4	100
200	0-10

D.4 Mix Design - shall meet the following:

Minimum compressive strength (28 days)	50 PSI
Maximum compressive strength (28 days)	150 PSI
Maximum fly ash per cubic yard	100 lb.
Minimum cement per cubic yard	50 lb.
Minimum slump	6 in.
Maximum slump	10 in.

4.4.2.7 TRENCHES ON HIGHWAYS AND STREETS. No work of any kind shall be performed in any public right-of-way without first obtaining an encroachment permit. Wherever any trenches will be in, or must cross any State road or any City road, alley or drainage way, the Contractor, or other responsible party, shall obtain any and all encroachment permits as are required for these crossings and shall become familiar with and abide by the rules and regulations of the Utah Department of Transportation and the City of Toquerville.

All Contractors or responsible parties excavating or encroaching over or under any public right-of-way including roads, drainage way, easements or other public property shall first obtain an encroachment permit in compliance with the applicable local ordinances prior to excavating.

All asphalt cuts shall be made with a diamond or carbide-tipped masonry or asphalt cutting saw unless otherwise approved by the City’s representative. No scarifier-tooth cuts, back-hoe or bucket rips will be allowed.

All backfilled trenches in roadways shall be patched with hot-mix asphalt within five days of initial excavation, unless otherwise directed by the City’s Representative. All backfill shall be in accordance with these standards.

All concrete or asphalt surfaces damaged or cut in trenching operations or other work within the right-of-way shall be restored to an “as-good or better condition” in accordance with the provisions outlined in Section 4.7 of these standards.

During the entire trenching, backfilling and patching operations, the Contractor shall be required to observe all safety and traffic control procedures as outlined in these standards.

The Contractor shall be responsible for maintenance of the trench, patch, and related work for a period of twelve (12) months from date of completion.

No more than four hundred (400) feet of trench shall be left unfilled at any time in one continuous run, unless otherwise approved by the City's Representative.

All streets and roads shall be kept free from dust and shall be open to through traffic. Approval to close the street must be obtained by the Contractor from the City Engineer or his designated representative. At least one-half (1/2) the width of any street or road shall be temporarily restored for use before excavation is commenced on the remaining portion of the street or road.

All excavation, backfilling and temporary resurfacing on any portion of any street or road shall be completed in one working day so that trenches are not left open or uncovered over night.

All requirements governing work within a right-of-way as contained in Section 2.5 (Barricades and Warning Signs - Work Area Protection) of these standards shall be adhered to.

All utility installations, i.e., gas, power, phone, cable T.V. and associated utilities, shall conform to the applicable test requirements contained within these standards for earthwork, compaction, base course, bituminous surface course, concrete and other materials.

4.4.2.8 CLEANING OF SANITARY SEWER LINES. SEE ASH CREEK SPECIAL DISTRICT.

4.4.2.9 CLEANING AND DISINFECTION OF WATER SYSTEMS. After being tested and prior to being placed in service, all lines shall be disinfected by chlorination. Prior to chlorination the entire line shall be flushed to ensure that all dirt or foreign objects have been removed from the line. Sufficient chlorine shall be added to ensure a residual of twenty five (25) parts per million in the water after twenty-four (24) hours standing in the pipe. Chlorine calcium hypochlorite dry chlorinating chemical solution may be used for this purpose. Methods of application shall be approved by the Water Department. Following chlorination, all treated water shall be drained and the pipeline thoroughly flushed with clean water.

All lines being disinfected shall be flushed after the specified twenty-four (24) hour contact period. Such flushing shall be continued until the water is free from excess chlorine. All lines being disinfected including hydrant laterals, branch lines, and dead-end mains shall be flushed. After final flushing the chlorine residual shall be tested by the Water Department. It is the contractor's responsibility to coordinate this test. The discharge of flushed water shall not cause erosion or damage to streets or other property. Procedures for discharge will

be subject to the review and approval of the City's Representative and Water Department.

4.4.2.10 SPECIAL REQUIREMENTS.

A. CONNECTIONS TO EXISTING FACILITIES - DRY TAPS. All connections to existing facilities shall be approved by the City Water Department. The Contractor shall make the approved connections to existing facilities as shown on the drawings. Dry connections to existing facilities shall be made only at locations shown on the drawings and shall be made at such times which will cause the least inconvenience to the water user(s). Dry connections shall be planned to minimize the duration of any shut down. The Contractor shall notify the Water Department at least two business days prior to beginning any connections to the existing facilities. When a connection to an existing water main is made, approximately four ounces of high test calcium hypochlorite (HTH) shall be placed in the pipe at each point where the existing main is cut. All new pipe and fittings at such connections shall be swabbed internally with an approved chlorine solution. All connections shall be made in the presence of the Water Department representative.

Valves shall not be operated without a Water Department representative present. Existing facilities shall not be shut down for connections to new facilities without prior Water Department approval. In no case shall an existing pipeline be shut down for a total of more than twenty four (24) hours (a maximum of three (3) eight-hour periods).

The actual work plan and schedule for making a connection to an existing facility which requires an existing pipeline to be shut down, shall be submitted to the Water Department and shall be approved before the Contractor will be allowed to proceed. The Contractor shall notify, by a method approved by the Water Department, all affected Water Department customers at least twenty four hours prior to shut down. Valves at connections to all existing facilities shall be operated by the Contractor, but only in the presence of the Water Department representative. If the water will be shut off for an extended period of time, the Water Department may require the Contractor to supply water for the Water System customers.

B. CONNECTION TO EXISTING FACILITIES - WET TAPS. (Steel and Steel Composite Mains). The Contractor shall furnish and install, at his sole cost and expense, all tapping fittings and valves for all wet taps on existing City water pipelines. The Contractor shall notify the Water Department a minimum of two (2) business days prior to the time the wet tap is required. No wet taps shall be made without prior approval.

Prior to tapping the main, the tapping valve and fittings shall be properly installed and pressure tested and approved by the Water Department. All wet taps to existing City water pipelines shall be made by the City Water Department at the sole expense of the Contractor requesting the work. The Contractor shall also provide all necessary equipment, labor and appurtenances necessary to complete the job. The wet tap materials shall be obtained from a source pre-approved by the Water Department.

4.4.3 QUALITY CONTROL. All underground pipelines shall be installed in accordance with these standards and tested as outlined below. These are minimum requirements and additional testing may be required.

4.4.3.1 TRENCH BACKFILL MOISTURE/DENSITY TESTING. Minimum testing of trench backfill shall be as follows:

Soil Proctor	One determination for each significant change in soil type as necessary to provide required compaction testing. Tests shall be ASTM D-1557 Method A or D (modified proctor).
--------------	--

Trench backfill moisture/ density determination -	Tests are required for trench backfill for every two hundred (200) lineal feet of trench or portion thereof and all service laterals, valve locations and manholes. Tests shall be run at the following trench elevations:
--	--

One test at top of pipe zone.

One test per two (2) feet of depth measured from the bottom of the subgrade to the top of the pipe zone. Tests shall be evenly spaced vertically through the trench with one (1) test at top of trench (bottom of subgrade).

Additional testing may be required by the City's Representative or soils testing laboratory to verify compaction.

Tests shall be according to ASTM D-1556 or D-2922 and D-3017. Moisture/density determinations shall be made in accordance with Section 3 of these standards. Proctors for all trench backfill compaction shall be determined using ASTM D-1557 modified proctor method.

4.4.3.2 SANITARY AND STORM SEWER LINE TESTING AND ACCEPTANCE. SEE ASH CREEK SPECIAL SERVICE DISTRICT STANDARDS AND SPECIFICATIONS.

4.4.3.3 WATER SYSTEM TESTING AND ACCEPTANCE. The Contractor shall test all water mains prior to final acceptance. Testing shall be done in the presence of the City Water Department Representative. When existing facilities must be included in the test and are determined to be faulty and not capable of holding test pressures, the existing facilities must be repaired prior to testing. When concrete thrust blocks are used, they shall be in place at least five days prior to initial filling of the line. (If high early strength concrete is used, three days will be required.)

A. PRESSURE TEST. After the pipe has been laid, including fittings, valves, corporation stops, services, and hydrants, and the line has been backfilled in accordance with these standards, each valved section, unless otherwise directed by the Water Department, shall be subjected to a hydrostatic pressure test of not less than two hundred pounds per square inch. The duration of each such test shall be two hours. Water added to maintain the pressure shall not exceed 0.3 gallons per inch diameter per one thousand lineal feet of pipe being tested during the two-hour test period.

Each valved section of pipe shall be slowly filled with water, and the specified test pressure measured at the lowest point of elevation. The pressure shall be applied by means of a pump connected to the pipe in a satisfactory manner. The pump, pipe connection, gauges, and all necessary apparatus for the test must be furnished by the Contractor. Gauges and measuring devices must be approved by the City Water Department and the necessary pipe taps shall be made as directed. Before applying the specified test pressure, all air shall be expelled from the pipe by a method approved by the Water Department.

Any cracked or defective pipes, fittings, valves, or hydrants discovered in the pressure test shall be removed and replaced with new materials in accordance with the standard specifications. The test shall be repeated until the water main passes the pressure test and is accepted by the City's Water Department or City's Representative.

B. OPERATIONAL INSPECTION. At the completion of the project and in the presence of the City's Representative, the Contractor shall operate all valves, hydrants, and water services to ascertain that the entire facility is in good working order; that all valve boxes are centered and valves are operational; that all hydrants operate and drain properly and that water is available at all meter boxes.

C. TEST RESULTS AND CERTIFICATES OF COMPLIANCE.

Test results shall be submitted for pressure and operational testing in accordance with current City Water Department requirements. Certificates of compliance from material suppliers may be required, at the option of the City's Representative, for any materials not specifically covered herein.

4.5 ROADWAY CONSTRUCTION. This subsection covers roadway construction including subgrade, subbase, roadbase, recycled aggregate materials (RAM), prime coat, tack coat, plant mix bituminous surfaces (dense and open graded), construction staking and other related work.

4.5.1 GENERAL REQUIREMENTS. The Contractor shall furnish all labor, material, equipment, tools, transportation, traffic control and supplies required to complete the work in accordance with the approved plans and these specifications. The approved plans do not purport to show all the details of the work. The plans are intended to illustrate the character and extent of work required and therefore, they may be, if necessary, supplemented or revised as the work progresses. The Contractor shall keep the most current set of approved plans available on the job site at all times.

The Contractor shall arrange the work and shall place and dispose of the materials being used so as not to interfere with the public during the course of the project. The Contractor shall join the new work with that of existing in an acceptable manner and shall perform all work in proper sequence.

The Contractor shall provide and maintain or have provided for, all necessary work zone traffic control in accordance with the requirements of Section 2.5 of these specifications. The Contractor shall also maintain the job site and all adjoining private and public areas in a clean, safe manner. This maintenance shall constitute continuous and effective work prosecuted day-by-day, with proper equipment and adequate work forces to keep all areas related to and adjoining the job site in a condition satisfactory to the City's Representative. If, at any time, the Contractor fails to comply with these provisions the City's Representative will immediately notify the Contractor of such non-compliance. If the Contractor fails to remedy the unsatisfactory maintenance within twenty-four hours after receipt of such notice, the City's Representative may immediately proceed to cause correction(s) to the job site and adjoining areas. The entire cost of this corrective maintenance will be billed to the Contractor and shall be paid in full prior to the City's acceptance of the work.

If a condition develops due to a lack of maintenance by the Contractor that is dangerous to public safety, the Contractor shall proceed to immediately remedy the condition with whatever means are available. The entire cost of the corrective remedy will be the Contractor's responsibility

4.5.2 CONSTRUCTION STAKING. Construction stakes shall be furnished and set, establishing lines and grades for roadway excavation including, but not limited to all cut

and fill slopes finished subgrade, finished subbase and finished roadbase grades for streets, curb & gutter, cross-gutters, sidewalks, drive approaches, any contiguous structures and utilities (to help prevent conflicts of location). In development related projects the Developer and his Engineer shall be responsible for all surveying and the accuracy thereof.

The line and grade stakes shall be, whenever possible, off-set from the construction area a minimum of five feet, and shall show the stationing (corresponding with the approved plans), off-set distance, required cut or fill to the finished grade, flow line, and TBC as indicated on the approved plans. Grade stakes with hubs set to the finished grade of the subgrade shall be painted appropriately. Stakes with hubs set to the finished grade of the subbase or roadbase shall be painted appropriately. Plastic "whiskers" may be used in connection with painted hubs. All stakes and grades shall be set by appropriate methods under the direction of the professional engineer whose seal is on the approved plans. The Contractor constructing the facilities should be provided with copies of the cut sheets generated during construction staking. Cut sheets shall include roadway stationing, reference elevations, grade elevations, etc.

The line and grade stakes and cut sheets along with the most current set of approved plans shall constitute the field control by which the work shall be executed.

The Contractor shall be responsible for preserving property markers, corner survey markers, construction survey stakes and marks for the duration of their usefulness.

If any construction survey stakes or markers are lost or disturbed and need to be replaced, such replacement shall be done at no expense to the City. At no time shall a permanent monument be removed without prior authorization by the City Engineer. When construction work encounters such monuments, the City Surveyor should be contacted immediately.

4.5.3 GRADE CONTROL SYSTEMS. Non-contact grade control systems may be used to establish the roadway elevations of subgrade, subbase and roadbase on public streets providing the following conditions are met.

4.5.3.1 The system shall be equipped with a "self diagnostic" function that continuously monitors all system functions and shuts the system down if an error in the system occurs. It shall also be equipped with a "thermistor" to electronically compensate for differences in air and ground temperature with a minimum operating range not less than zero to 160 degrees F. (-18 to 71 degrees C.).

4.5.3.2 The system shall meet the following minimum specifications:

- Blade slope sensor resolution 0.01% slope
- Main fall sensor resolution 0.01% slope
- Rotation sensor resolution 0.1 degree
- Tractor grade controller ±0.015 foot(4.5 mm) accuracy

- Cross-slope resolution 0.1% slope or 0.01 foot/10 foot (3 mm in 3m).
- Cross-slope system accuracy 0.02 foot/10 feet (6 mm in 3

4.5.3.3 A system meeting the above requirement must be properly installed on a “tight”* properly maintained motor-grader.

*Meeting the equipment manufacturer's service specification tolerances for all controlling surfaces and connecting points that effect the ability of that specific type of equipment to provide proper grade control.

With all the above conditions met the system will be permitted to be used, providing a preset grade and line for curb & gutter, edge of pavement or curb grade line has been established by the Engineer.

The City’s Representative has the right to prohibit the use of such equipment, if in his opinion, the equipment has not been properly maintained or is not being properly operated.

4.5.4 GEOTECHNICAL INVESTIGATION. A geotechnical investigation shall be conducted under the direction and control of a Geotechnical Engineer experienced in flexible pavement design. The investigation shall include a thorough exploration and sampling program of the subgrade to determine the nature and engineering properties of the on-site soils within the roadway construction areas. The minimum sampling and testing requirements shall be as outlined in Section 3.2.5 and where otherwise outlined in these specifications.

The structural details shown on the plans and/or Standard Drawings, and Table 4.2 are minimum requirements. The actual structural section for each roadway shall be designed by accepted engineering design methods for flexible pavement (i.e., AASHTO, UDOT, Caltrans). Required subgrade soil properties shall be obtained from an on-site geotechnical investigation. Required traffic design traffic information is provided in Table 4.2. When, in the opinion of the City Engineer the traffic information listed is inappropriate for the street under consideration the Traffic Index will be adjusted accordingly.

4.5.5 ROADWAY SUBGRADE. This subsection shall govern the preparation of natural, filled or excavated material prior to placement of subbase. The preparation of subgrade shall extend a minimum of one foot beyond the proposed construction limits. This includes roadways, curbs & gutters, drive approaches, sidewalks or any other roadway structures.

4.5.5.1 PREPARATION. The subgrade soils shall be prepared by scarifying and processing to a minimum depth of one foot unless otherwise recommended by the geotechnical firm approved by the City representative.

Unsuitable material found below the processing depth such as saturated soils from groundwater, expansive soils, soluble soils, deleterious and/or organic materials shall be addressed by a Geotechnical Engineer who shall provide a written recommendation to the City’s Representative for approval prior to performing any work in the areas being addressed.

**TABLE 4.2
Minimum Roadway Structural Requirements**

Classification	Traffic Index	(3)(4) Roadway Minimum Asphalt Pavement (inches)	(4) Required Roadway Road-Base (inches)	(5) Required Roadway Sub-base (inches)	Sidewalk Minimum Concrete Thickness (inches)	Sidewalk Minimum Road-Base Thickness (inches)	Driveway Minimum Concrete Thickness (inches) (5)	Driveway Minimum Road Base Thickness “residential” (inches) (6)
Residential - Local	5	2.5 (1)	6	varies	4	4	6	6
Residential - Standard	5	2.5 (1)	6	varies	4	4	6	6
Residential - Collector	5.5	3	6	varies	4	4	6	6
Major Collector	6	3	6	varies	4	4	6	8
Minor Arterial	7	3.5	7	varies	4	4	8	8
Major Arterial	8	4	8	varies	4	4	8	8
Commercial Local	10	4	8	varies	4	4	8 (2)	8
Industrial Local	10	5	12	varies	4	4	9 (2)	8

(1) Asphalt pavements containing more than 1% gypsum (CaSO₄+2H₂O calcium sulfate, dehydrate) shall be a minimum of 3" thick; consisting of 2" of 3/4" dense-graded asphalt base course containing no more than 2% gypsum and 1" of 1/2" dense-graded asphalt wearing course with less than 1% gypsum. This road classification does not require a prime coat unless otherwise specifically designated by the City Representative.

(2) #4 rebar to be placed three inches above the bottom of concrete spaced 12 inches on center each way.

(3) All wearing courses shall have less than 1% gypsum content.

(4) Thickness may vary based upon structural section design by a registered professional engineer experienced in flexible pavement design. Minimum values are shown.

(5) Roadway sb-base is required. The thickness varies based upon the structural section designed by the engineer.

(6) Thickness’ shown here do not apply outside the public right of way or behind the back of sidewalk unless otherwise designated.

4.5.5.1 (continued) Uniform pervious soils that allow the immediate penetration of water to a depth of one foot, will not require scarifying and processing unless a condition previously stated requires it. When scarifying and processing are not required, the moisture content of the top one foot of the subgrade material shall be brought to not less than two percent (2%) of optimum by the addition of water on the surface, and the material shall be compacted by approved equipment to the specified compaction requirements.

When scarifying and processing, the roadbed shall be loosened to a depth of at least one foot, then alternate blading, moistening and rolling will be required to provide a smooth, even and uniformly compacted course true to cross-section and grade. Moisture content at the time of processing and testing shall be not less than two percent (2%) of optimum. All rocks larger than six inches in diameter shall be removed.

4.5.5.2 TOLERANCES. When subbase material is placed on the subgrade the subgrade tolerance shall not vary more than 0.10-foot from the specified grade and cross-section. However, when roadbase or recycled aggregate materials (RAM) placed on the subgrade the subgrade tolerances shall not vary more than 0.05-foot from the specified grade and cross-section.

4.5.6 SUBBASE - CLASS I AND CLASS II. All gravel pits supplying aggregate shall be UDOT approved pits. Subbase for all roadways and associated areas shall consist of select materials, either natural or crushed. Aggregate wear shall be less than fifty percent (50%) when tested by AASHTO T-96. The material passing the 40 (4.75 mm) sieve shall be non-plastic per AASHTO T-90. The subbase shall contain no more than three percent (3%) gypsum or any other deleterious or organic materials by weight. The test for gypsum shall follow City of Toquerville Chemical Quantitative Analysis of Gypsum in Aggregates, Test Procedure S-3171-96.

Prior to delivering any subbase to any site the supplier shall submit, in writing, a job-mix gradation to the City Engineer for approval. The job-mix gradation shall have definite single values for the percentage of aggregate passing each specified sieve based on the dry weight of the aggregate. Dry weight values shall fall within the band limits shown in Table 4.3.

Annual job-mix gradations shall be submitted in writing to the City Engineer for approval prior to January 31 each calendar year or upon selection of new aggregate sources. Any revisions to the approved job mix gradations shall fall within the requirements listed above.

If a supplier does not have an approved job-mix gradation that is current for the aggregate source or calendar year, the "Ideal Gradation" in Table 4.3 will apply.

The subbase mixture placed on projects during one day's operation shall come from a single source. Intermixing from more than one source will not be permitted.

Subbase material shall be deposited and spread in uniform lifts not to exceed eight inches compacted thickness for Class I and six inches compacted thickness for Class II without segregation of size. Each layer shall be compacted for the full width and depth by mechanical means of compaction. When mixing, moistening and placing subbase the moisture content shall be not less than two percent (2%) below optimum. However, caution shall be used to avoid over watering to a state of instability. Alternate blading and rolling will be required to provide a smooth, evenly moistened and uniformly compacted

course true to cross-section and grade. Locations inaccessible to rolling shall be compacted with mechanically operated hand tampers. The subbase shall be compacted to not less than ninety-five (95%) percent maximum dry density as determined by ASTM D1557-78 or AASHTO T-180 Method D. Subbase tolerances when compacted shall not vary more than 0.05-foot from the specified grade and cross-section.

Table 4.3

SUBBASE AGGREGATE GRADATION

PERCENTAGE OF TOTAL AGGREGATE PASSING					
SIEVE SIZE		CLASS I BAND LIMITS	IDEAL GRADATION	CLASS II BAND LIMITS	IDEAL GRADATION
METRIC	AMERICAN STANDARD				
152.4 mm	6"	100	100	--	--
76.20 mm	3"	90 - 100	95	100	100
50.80 mm	2"	80 - 100	90	90 - 100	95
25.0 mm	1"	70 - 90	80	70 - 90	80
12.5 mm	½"	51 - 75	63	51 - 75	63
4.75 mm	#4	31 - 65	48	31 - 65	48
1.18 mm	#16	16 - 40	28	16 - 40	28
.075 mm	#200	2 - 12	7	2 - 12	7

4.5.7 UNTREATED ROADBASE - ONE INCH AND THREE-QUARTER INCH.

All gravel pits supplying aggregate shall be UDOT approved pits. Roadbase for all roadways and associated areas shall consist of select materials, natural and/or crushed. Coarse aggregate shall be all material retained on the #4 (4.75 mm) sieve, and shall be crushed stone, crushed gravel, or crushed slag with a minimum of forty percent (40%) fractured faces per FLH designation T-506-94. Fine aggregate may be a natural, or manufactured, product and shall pass through a #4 (4.75 mm) sieve. All aggregates shall be clean, hard, tough, durable and sound containing no more than two percent (2%) gypsum and be free from other deleterious and/or organic materials and harmful adherent coatings. The test for gypsum shall follow City of Toquerville Chemical Quantitative Analysis of Gypsum in Aggregates, Test Procedure S-3171-96.

Aggregate wear shall be less than fifty percent (50%) when tested by AASHTO T-96 and the material passing the #40 (.0425 mm) sieve shall be non-plastic per AASHTO T-90. The dry-rodded unit weight shall be at least seventy five pounds per cubic foot (1200 kg/m³) per AASHTO T-19.

Prior to delivering any roadbase to any site, the supplier shall submit, in writing, a job-mix gradation and a standard aggregate gradation plot to the City Engineer for approval. The job-mix gradation shall have definite single values for the percentage of aggregate passing each specified sieve based on the dry weight of the aggregate. Dry weight values shall fall within the band limits shown in Table 4.4, and provide a uniform curve when plotted on a standard aggregate gradation chart. The City Engineer has the right to request modification to the job-mix gradation to provide an acceptable curve. The accepted job mix will then become the target gradation for the aggregate source for the calendar year.

Annual job-mix gradations shall be submitted in writing to the City Engineer for approval prior to January 31 each calendar year, or upon selection of new aggregate sources. Any revisions to the approved job-mix gradation shall fall within the requirements listed above.

If a supplier does not have an approved job-mix gradation that is current for the aggregate source, or calendar year, the "Ideal Gradation" in Table 4.4 will apply.

The roadbase placed on a project during one day's operation shall come from a single source. Intermixing from more than one source will not be permitted.

Roadbase shall be placed in layers compatible with the equipment and not exceeding eight (8) inches in non-compacted thickness. Where the required thickness is more than eight inches the roadbase shall be spread and compacted in two or more layers of approximately equal thickness. However, if vibratory compaction equipment of a type approved by the City's Representative is used, and the requirements for density and moisture content are complied with, the noncompacted thickness of any one layer may be increased to ten (10) inches. Each layer shall be compacted for the full width and depth by mechanical means. When mixing, moistening and placing roadbase the moisture content shall be not less than two percent (2%) below optimum. Care shall be used to avoid overwatering. Alternate blading and rolling will be required to provide a smooth, evenly moistened and uniformly compacted course true to cross-section and grade. Locations inaccessible to rolling shall be compacted with mechanically operated hand tampers. The roadbase shall be compacted to not less than ninety-five percent (95%) maximum dry density as determined by ASTM D-1557-78 or AASHTO T-180 method D. Roadbase tolerances when compacted shall meet or exceed the required minimum thickness and shall not vary more than 0.02 foot from the specified grade and cross-section at the time the asphalt pavement is placed.

When the roadbase surface is used to convey traffic, or is left unpaved for an extended period of time, the contractor shall preserve the integrity and grade and an asphalt prime coat meeting the requirements in Section 4.5.8 shall be applied. When asphalt prime is not used, the contractor shall maintain the roadbase moisture, structural integrity and finish, to the finished tolerances of this subsection.

**Table 4.4
ROADBASE AGGREGATE GRADATION**

PERCENTAGE OF TOTAL AGGREGATE					
Sieve Size		1 inch/ 25mm Band Limits	Ideal Gradation	3/4 Inch/ 19mm Band Limits	Ideal Gradation
Metric	American Standard				
25mm	1"	100	100	–	–
19mm	3/4"	–	–	100	100
12.5mm	1/2"	79-91	85	–	–
9.5mm	3/8"	--	--	78-92	85
4.75mm	#4	49-61	55	55-67	61
1.18mm	#16	27-35	31	28-38	33
.075mm	#200	7-11	9	7-11	9

4.5.8 PRIME COAT. Prime coat is required for all roadway work unless otherwise approved by the City Engineer. This work shall consist of preparing and treating an existing aggregate base with bituminous material and blotter material, if required, in accordance with these specifications and in conformity with the lines shown on the plans or established by the City’s Representative. The type and grade of bituminous material shall be MC-70 liquid asphalt, unless otherwise approved by the City’s Representative.

The Contractor shall provide equipment for heating and applying the bituminous material. The asphalt distributor shall be so designed, equipped, maintained and operated that bituminous material will be applied uniformly on variable widths of surface at readily determined and controlled rates from 0.05 to 2.0 gallons per square yard with uniform pressure and an allowable variation from any specified rate not to exceed 0.02 gallon per square yard. Distributor equipment shall include a tachometer, pressure gauges, accurate volume measuring devices or a calibrated tank, and thermometer for measuring temperatures of tank contents. Distributors shall be equipped with a power unit for the pump and full circulation spray bars adjustable laterally and vertically.

Bituminous material shall not be applied on a wet surface that has free standing water, or when the atmospheric and surface temperature is less than 50⁰ F. (10⁰C.) or when weather conditions, in the opinion of the City’s Representative, would prevent the proper application of the prime coat. The surface upon which the bituminous prime coat will be placed shall conform to the established lines and grades, shall be smooth and uniform and shall be compacted to the required density with the optimum moisture content at plus, or minus, two percent (2%). If, for any reason, the required density and/or moisture

deteriorates between the time the gravel course was compacted and the time the prime coat is placed, the surface shall be recompact and/or moisture conditioned to the required density and moisture content.

Bituminous material shall be applied to the width of the section to be primed by means of a pressure distributor in a uniform, continuous spread. When traffic is maintained, not more than one-half of the width of the section shall be treated in one application. Traffic will not be allowed on the treated surface until the bituminous material is absorbed and will not adhere to the vehicle tires. Care shall be taken that the application of bituminous material at the junctions of spreads is not in excess of the specified amount. Skipped areas or deficiencies shall be corrected.

Application rate shall be 0.25 gallon per square yard, or as directed by the City's Representative. At the time of placement the temperature of the liquid asphalt shall be uniform and not less than 120 degrees F. (49 degrees C.) nor more than 180 degrees F. (82 degrees C.).

If the bituminous material fails to penetrate within forty-eight hours, blotter material shall be spread as required to absorb any excess bituminous material. All loose blotter material shall be completely removed from the treated areas prior to placing surfacing material. Prior to placing asphalt concrete, additional prime coat shall be applied as directed by the City's Representative to areas where the prime coat has been damaged, and loose or extraneous material shall be removed.

Sand blotter material shall meet the following requirements. The material may be accepted in the stockpile at the source.

<u>REQUIRED TESTS</u>	<u>TEST METHODS</u>
Sieve Analysis	AASHTO T27
Sampling Aggregate	ASTM D 75
Organic Impurities	ASTM C 40

GRADATION REQUIREMENTS

Percentage by Weight

<u>Sieve Sizes</u>	<u>Passing Sieve</u>
½ Inch	100
No. 4	90 - 100
No. 16	30 - 75
No. 200	0 - 12

Liquid asphalt shall not be sprayed upon adjacent pavements, that portion of the traveled way being used by traffic, structures, railings and barriers, markers, adjacent property and improvements, and other roadway improvements or facilities not mentioned herein.

4.5.9 TACK COAT. This work shall consist of preparing and treating an existing bituminous or concrete surface with asphaltic emulsion in accordance with these specifications and in conformity with the lines shown on the plans or established by the City's Representative. The type and grade of bituminous material shall be SS-1h asphalt emulsion, unless otherwise directed.

Asphalt emulsion used as a tack coat between courses of plant mix surface, or over an existing surface, shall be prepared for application by using warm water to cut back the emulsion in the quantity of fifty percent (50%) of the emulsion by weight.

Bituminous material shall be applied to the width of the section to be tacked by means of a pressure distributor in a uniform, continuous spread. Care shall be taken that the application of bituminous material at the junctions of spreads is not in excess of the specified amount. Skipped areas or deficiencies shall be corrected.

The Contractor shall provide equipment for heating and applying the bituminous material. The asphalt distributor shall be so designed, equipped, maintained and operated that bituminous material will be applied uniformly on variable widths of surface at readily determined and controlled rates from 0.05 to 2.0 gallons per square yard with uniform pressure and with an allowable variation from any specified rate not to exceed 0.02 gallon per square yard. Distributor equipment shall include a tachometer, pressure gauge(s), accurate volume measuring devices or a calibrated tank, and a thermometer for measuring temperatures of tank contents. Distributors shall be equipped with a power unit for the pump and full circulation spray bars adjustable laterally and vertically.

Application of tack coat may occur only when the surface and air temperature is 50 degrees F. (10 degrees C.) and rising. The surface shall be clean, dry, free of irregularities and shall be smooth and uniform.

At the time of placement the temperature of the asphaltic emulsion shall be uniform and not less than 75 degrees F. (24 degrees C.) nor more than 130 degrees F. (54 degrees C.). The tack shall be applied at a rate of 0.05 to 0.10 gallon per square yard. The rate of application may be adjusted by the City's Representative.

Liquid asphalt shall not be sprayed upon adjacent pavements, structures, railing, barriers, markers, adjacent property improvements, and other facilities not mentioned herein.

4.5.10 DENSE-GRADED ASPHALT. This work shall consist of mixing, laying and compacting an asphalt course of one or more layers composed of aggregate, asphalt cement, applicable additives and lime, as required. All materials shall be mixed at a central mixing plant.

4.5.10.1 RELATED WORK. Work related to asphalt concrete pavement shall include surface preparation, prime coat, tack coat, transporting, placement, compaction and finishing of asphalt mixture as required. Work zone traffic

control shall be in accordance with the requirements of Section 2.5 of these specifications.

4.5.10.2 ASPHALT CEMENT. Viscosity graded asphalt cement shall meet AASHTO designation M-226-80 (1993). Viscosity is to be measured at 140°F (60°C) when used in pavement construction. The asphalt cement shall be homogeneous, free from water, and shall not foam when heated to 347° F (175° C). Sampling and testing of asphalt cements shall be in accordance with the following AASHTO Standard Methods:

- | | |
|--------------------------------------|------|
| • Sampling | T40 |
| • Viscosity at 140°F (60°C) | T202 |
| • Viscosity at 275°F (135°C) | T201 |
| • Penetration | T49 |
| • Flash point (COC) | T48 |
| • Solubility in bituminous materials | T44 |
| • Thin-film oven test | T179 |
| • Ductility | T51 |
| • Spot test | T102 |
| • Rolling thin film oven test | T240 |
| • Water | T55 |

The asphalt cements shall conform to the requirements given in Table 4.5.

**TABLE 4.5
Paving Grade Liquid Asphalt Requirements**

	AC-10	AC-20	AC30
Viscosity: 140° (60°C) poises	1,000 ± 200	2,000 ± 400	3,000 ± 600
Viscosity: 275°F (135°C), Cs-minimum	250	300	350
Penetration: 77°F (25° C), 100g, 5 sec-min.	80	60	50
Flash Point: COC, C(F)-minimum	219(425)	232(450)	232(450)
Solubility in trichloroethylene: percent-minimum	99.0	99.0	99.0
Tests on residue from thin-film oven test:			
Loss on heating: percent - maximum (1)	0.5	0.5	0.5
Viscosity: 140°F (60°C), poises-maximum	4,000	8,000	12,000
Ductility: (77°F (26°C), 5cm per minutes), cm-minimum	75	50	40
Spot test (when and as specified (2) with: Standard naphtha solvent	Negative for all grades		
Naphtha-Xylene-solvent, % Xylene	Negative for all grades		
Hepthan-Xylene-solvent, % Xylene	Negative for all grades		

- (1) The use of loss on heating requirement is optional.
- (2) The use of the spot test is optional. When it is specified, the City Engineer's Representative shall indicate whether the standard naphtha solvent, the naphtha-xylene solvent, or the heptane xylene solvent will be used in determining compliance with the requirement. If xylene solvent is used the percentage of xylene shall be indicated.

4.5.10.3 SHIPMENT OF ASPHALT MATERIAL. Asphalt cement shall be uniform in appearance and consistency and show no foaming when heated to the specified loading temperature. Shipments of asphalt shall not be contaminated with any other type or grade of asphalt material. A bill of lading shall accompany each shipment of material and shall include the following information:

- Type and grade of material.
- Type and amount of additives used, if applicable.
- Destination.
- Consignee's name.
- Date of shipment.
- Truck identification.
- Loading temperature.
- Net weight or net gallons corrected to 60°F (16.6°C).
- Specific gravity.

- Bill of lading number.
- Manufacturer of asphalt material.

4.5.11 HYDRATED LIME FOR ASPHALT MIXTURE. The physical properties of hydrated lime shall conform to ASTM C-1097, subparagraph d.1; use test method ASTM C-110, paragraph 6.

The water used in saturating the aggregate to be coated shall be potable or water that is clean and free of dirt, silt and other damaging material. The aggregate bulk specific gravity (saturated-surface-dry (SSD)) shall be not less than one and one-half percent (1 ½%) nor more than three percent (3%) using AASHTO T-85 for the coarse aggregate retained on a No. 4 (4.75 mm) sieve and AASHTO T-84 for the fine aggregate passing the No. 4 (4.75 mm) sieve. Hydrated lime shall be applied at a rate determined during the Marshall Design requirements in Table 4.6, unless otherwise directed by the City Engineer. Two options for coating the aggregate with lime are as follows:

4.5.11.1 Aggregate shall be monitored for SSD by taking a belt cut between the stockpile and the pugmill or drum. The pugmill or drum shall be equipped with metering devices that will introduce the required amount of hydrated lime and water into the mixer to produce an aggregate SSD of one and one-half percent (1½%) to three percent (3%).

4.5.11.2 Use of a lime slurry of one (1) part lime and three (3) parts water by volume may be used, if the plant is equipped with a mixing chamber that can maintain the lime suspension in the slurry. Spraybars for introducing the required quantity of slurry into the mixer shall be equipped with a positive shutoff. If this option is used the aggregate stockpile shall be maintained at two percent (2%) SSD.

Asphalt plants shall provide a positive signal system that automatically closes down the cold feed when the appropriate amount of hydrated lime and water ceases to be introduced into the aggregate. This shall be accomplished by the use of interlocked and synchronized metering devices and feeders. The plant shall be equipped in such a way that the quantity of hydrated lime incorporated into the mix can be readily checked at any time.

**TABLE 4.6
MARSHALL DESIGN REQUIREMENTS**

TRAFFIC CATEGORY*	I		II	
ASTM D-1559 (number of blows)	75		50	
TEST PROPERTY	MIN	MAX	MIN	MAX
MARSHALL STABILITY, LB.	1500	--	1200	--
FLOW, 0.01 IN	8	16	10	18
AIR VOIDS: PERCENT	3	5	3	5
VOIDS IN MINERAL AGGREGATE (VMA)	13	17	13	17
FRACTURED FACES RETAINED ON THE NO. 4 (4.75 mm) SIEVE PER FLH DESIGNATION: T-506-94 2.1	100%	---	75%	--
SAND EQUIVALENT PER AASHTO T-176-86 (1993) 4.3.2, 4.3.3	55	---	40	--
WEAR TEST AASHTO T-96	---	30%	---	30%
DRY-RODDED UNIT WEIGHT AASHTO T-19	AM. STD.	METRIC	AM. STD.	METRIC
	75 pounds per cubic foot	1200 kg/m ³	75 pounds per cubic foot	1200 kg/m ³
STRIPPING TESTS: AASHTO T-283 ASTM D-4687 including Note 5	Shall be used to determine the required amount of hydrated lime or anti-stripping agent in the asphalt. The mix design shall have a tensile strength ratio of 70 percent.			

* Traffic Category I applies to arterial streets or truck routes with a Traffic Index of seven or more.
Traffic Category II applies to streets with a Traffic Index of less than seven.

4.5.12 AGGREGATE. The requirements for crushed rock, rock dust, gravel, stone, slag, and sand are included in this subsection. All aggregate shall be clean, hard, sound, durable and uniform in quality. The quality of soft, friable, thin, elongated, laminated pieces and disintegrated materials will be determined by the supplier's professional Geotechnical Engineer at the time the mix design is submitted, at which time the City's Representative will have the option to approve or reject the material. Organic matter, oil,

alkali or other salts shall not exceed two percent (2%) total weight. In the surface course this material may be restricted to less than one percent (1%) by weight.

4.5.12.1 Aggregate for three-quarter (3/4) inch (19.0 mm) Category I (NR), (see Table 4.7) shall be one hundred percent (100%) crushed material (all manufactured). This is considered a non-rutting (NR) mix.

4.5.12.2 Coarse aggregate for three-quarter (3/4) inch standard (19.0 mm standard) and one-half inch (12.5 mm) Category II (see Table 4.7) shall be retained on the No. 4 (4.75 mm) sieve and shall have no less than seven-five percent (75%) fractured face material as defined in FLH T 506-94 2.1.

4.5.12.3 Fine aggregate for other than the three quarter (3/4) inch NR, may be a natural or manufactured product. It shall pass the No. 4 (4.75 mm) sieve. It shall be clean, hard-grained angular, non-plastic, and have no more than two percent (2%) by weight of organic matter or other detrimental substances, including gypsum.

4.5.12.4 The test for gypsum shall be conducted using City of Toquerville Chemical Quantitative Analysis of Gypsum in Aggregates, Test Procedure S-3171-96.

4.5.12.5 Surface courses, or asphalt wearing courses, shall be free from organic materials and contain less than one percent (1%) by weight of soluble minerals, such as gypsum, and phosphates.

TABLE 4.7

DENSE-GRADED ASPHALT AGGREGATE GRADATION

PERCENT OF TOTAL AGGREGATE PASSING (DRY WEIGHT)				
TRAFFIC CATEGORY		I	II	II
METRIC		19.0 mm NR	19.0 mm std.	12.5 mm
AMERICAN STANDARD		3/4 inch NR	3/4 inch std.	1/2 inch
SIEVE SIZE				
METRIC	AMERICAN STANDARD			
25.0 mm	1 inch	---	---	---
19.0 mm	3/4 inch	100	100	---
12.5 mm	1/2 inch	74 - 99	---	100
9.5 mm	3/8 inch	69 - 91	75 - 91	---
4.75 mm	#4	49 - 65	46 - 62	60 - 80
2.36 mm	#8	33 - 47	---	---
1.18 mm	#16	21 - 35	22 - 34	28 - 42
.300 mm	#50	6 - 18	11 - 23	11 - 23
.075 mm	#200	2 - 6	5 - 9	5 - 9

4.5.13 STORING, MIXING AND SHIPPING OF PLANT MIX BITUMINOUS PAVEMENTS. Hot mix plants may be batch or drier-drum type plants (with not less than four aggregate bins).

4.5.13.1 STORAGE. The various natural and manufactured aggregates shall be stored separately. The various aggregate sizes shall be placed in bins which allow the material to be properly and evenly fed to the dryer to ensure a uniform flow of properly combined aggregates. When placing materials in storage bins, or when moving them from storage to the feeder, no method will be used which may cause segregation, degradation or the intermingling of different size aggregates. Materials not meeting the gradation requirements shall be reprocessed to comply with the requirements. All scales and meters shall be certified and sealed by the Utah Department of Agriculture, Division of Weights & Measures, annually and when the plant has been moved.

4.5.13.2 BATCH PLANT METHOD. The aggregates shall be dried and heated for sufficient time in the dryer so that the moisture content of the aggregate will not be greater than one percent (1%). The dryer shall be equipped with a calibrated thermometer to determine the temperature of the aggregate leaving the dryer. The thermometer shall be accurate to the nearest 10°F (5.5°C), and shall be installed in such a manner that a fluctuation of 10°F (5.5°C) in the aggregate temperature will be indicated within one minute and be clearly read from the operator's platform.

After drying, the aggregates shall be evenly fed to screens having clear square openings to separate, classify and quantify materials for hot storage bins. The aggregate passing these screens shall be separately stored in individual bins until proportioned into the mixer.

Each bin shall be provided with an opening to prevent overflow into adjacent bins. All overflow material shall be returned to an appropriate storage area for reprocessing.

If a substantial change is made in the cold feed to accommodate the demands of a different type of mixture, the hot storage bins shall be emptied and recharged with the correct materials.

All materials shall be proportioned by weight. The aggregate scales shall be fully automatic, solid-state digital strain-gage transducer with a capacity exceeding one and one-quarter times the total amount of materials to be weighed in one operation. Asphalt binder shall be weighed by a fully automatic scale having a capacity of not more than five hundred pounds (227kg) with one-pound (0.45kg) resolution for mixers with a manufacturer's rated capacity of four thousand pounds (1814kg) or less, and a capacity of not more than one thousand pounds (454 kg) with one pound (0.45kg) resolution for mixers with a manufacturer's rated capacity over four thousand pounds (1814kg).

When bag house fines or mineral filler is used, it shall be proportioned by weight or volume. The method used shall uniformly feed the material within ten percent (10%) of the required amount.

Mixing shall be done with a twin shaft pug mill-type mixer and shall be operated at the speed recommended by the manufacturer. The paddles shall be of sufficient size and quantity to deliver a uniform mixture.

The weight of the material that may be mixed per batch shall not exceed the manufacturer's rated capacity of the mixer, nor exceed an amount that will permit complete mixing of all the materials. Dead areas in the mixer, in which the material does not move or is not sufficiently agitated, shall be corrected by reduction in the volume of materials or by repairs to the mixing equipment before any further production will be allowed.

The entire batch shall be mixed until all the materials are thoroughly blended. The batch mixing time will begin on the charging stroke of the weight hopper dump mechanism and conclude when discharge from the mixer has started. The mixer shall be equipped with a time lock which locks the mixer discharge gate for the mixing period and actuates an indicator light visible from the operator's platform.

The aggregate and liquid asphalt drop time into the mixer shall not exceed ten seconds and the time for mixing materials will not be less than thirty seconds per batch. If the City's Representative determines that the mixture is not thoroughly blended, and all aggregate properly coated with asphalt cement, the mixing time will be increased to produce a homogeneous material.

The weight-box housings and mixer platform shall provide safe and convenient access with properly sized gates and tracks for sampling the discharged materials.

4.5.13.3 DRIER-DRUM METHOD. When a drier-drum is used, aggregate shall be fed directly to the mixer drum at a uniform rate, and monitored for combined aggregate moisture and gradation by taking belt cut samples. A minimum of one moisture content check and gradation test per day and one moisture and gradation test per five hundred tons (551 tonne), or as conditions require, shall be made. The results of these tests shall be kept on logs for review by the City's Representative. Sampling and testing may be performed by the manufacturers properly trained and equipped staff or by an approved testing lab. If sampling is performed by the manufacturer, five percent of the samples shall be split and a testing firm approved by the City shall verify that the test results accurately represent the product being tested by the manufacturer. The sample to be split may be selected at random by the manufacturer's quality control team, or the City's Representative.

If the cold feed material gradation is outside the allowable mean of deviations of the approved mix design as determined in Section 4.5.24, production shall be stopped until the necessary corrections are made. If the moisture content of the cold feed reaches five percent, production shall be stopped until certified by an approved independent materials testing firm under the direction of a Registered Professional Engineer, licensed in the state of Utah. This firm shall then be

employed to provide continuous plant quality control and testing, and production may be resumed.

All production shall be prohibited if the cold feed material reaches seven percent moisture, without exception. During lay down operations, if in the opinion of the City's Representative excess moisture is present in the asphalt material, it shall be sampled and tested for moisture under AASHTO T-164-94 Note-6 or ASTM D 2172-93 Note 3. Asphalt found to contain excess moisture shall be removed in its entirety and properly disposed of.

The drier-drum shall be equipped with a calibrated thermometer to determine the temperature of the mixed materials leaving the drum. The thermometer shall be accurate to the nearest 10°F (5.5°C), and shall be installed in such a manner that changes of 10°F (5.5°C) in temperature of the mixed material will be shown within one minute and be clearly read from the operators station.

Asphalt cement shall be measured through a meter under constant pressure with a gage indicating the pressure and temperature at all times. This metering system shall be calibrated and certified for accuracy every six months, or whenever the plant is moved.

During any day's run, the temperature of asphalt cement shall not vary more than 50°F (10°C). If the meter loses pressure the operator's computer shall be equipped to warn the operator or automatically shut down the system.

The aggregate feeders for each material in the mixture and for the combined aggregates shall be equipped with devices by which the rate of feed can be determined while the plant is in full operation. The combined aggregate shall be weighed on a belt scale. The scale shall be of such accuracy that, when the plant is operating between thirty percent and one hundred percent of belt capacity, the average difference between the indicated weight of the material delivered and the actual weight delivered will not exceed one percent of the actual weight for three two-minute runs. For any of the three individual two-minute runs, the indicated weight of material delivered shall not vary more than two percent from the actual weight delivered.

The belt scale for the combined aggregate, the other proportioning devices for additives and the asphalt cement proportioning meter shall be interlocked so that the rates of feed will be automatically adjusted to maintain the proper material ratios as designated by the approved mix design. The plant shall not be operated unless this automatic system is operable and in good working condition.

The asphalt cement meters, additive feeders and aggregate belt scales used for metering the aggregate additives and asphalt cement into the mixer shall be equipped so that the actual quantities of asphalt cement, additives and aggregate introduced into the mixture can be determined.

Mixing shall be performed for sufficient time, and at a sufficiently high temperature, so that at discharge from the mixer, the sizes of aggregates are uniformly distributed throughout the completed mixture and all particles are thoroughly and uniformly coated with asphalt cement.

Temperature of the completed mixture at discharge from the drum shall not exceed 325°F (163°C) for all dense-graded mixes using AC-10, AC-20 and AC-30 grades of asphalt cements. Maximum temperatures for open-graded mixes using AC-20 and AC-30 shall not exceed 275°F (135°C). Open-graded mixes using AC-20R shall not exceed 325°F (163°C).

The mixed material shall be discharged from the drum into a surge silo of not less than forty tons in capacity. The manufacturer shall also provide a means of diverting the flow of material away from the silo, when starting and stopping the plant production, to prevent incompletely or improperly mixed portions of the mixture from entering.

Paving grade asphalts shall be added to the aggregates, in both batch and drier-drum plants, at a temperature between 285°F (140°C) and 350°F (177°C). The temperature of the aggregates at the time of adding the asphalt cement shall not be less than 265°F (130°C), nor more than 325°F (163°C). A thermometer with a 500°F (260°C) capacity, and accurate to 10°F (5.5°C) will be fixed in the asphalt cement feed line or storage tank at a suitable location to view when sampling the asphalt. The manufacturer will provide a suitable sampling outlet in the asphalt cement feed lines connecting the storage tank(s) to the asphalt cement meter. The sampling valve shall consist of a one-half inch (12.7 mm) or three-quarter inch (19 mm) valve constructed in such a manner that a one-quart (.95 liter) sample may be withdrawn slowly at any time during plant operations. The sampling valve shall be placed in the least hazardous location that is readily accessible. A drainage receptacle shall be provided for flushing the valve prior to sampling. One gallon (3.8 liters) shall be drawn from the sampler prior to taking the sample.

4.5.14 ASPHALT CONCRETE SURGE AND STORAGE SILOS. The type of conveying equipment used to deliver the hot-mix asphalt from the discharge chute on the drier-drum mixer or from the hopper under the pugmill may be either a variable or constant speed - bucket elevator, drag slat conveyor or hot material belt conveyor.

The manner in which the mix exits from the conveyor or elevator and enters the top of the silo, shall be such as to prevent segregation of the completed asphalt mixture. Properly installed, maintained and operated systems such as rotating spreader chutes, batchers and gob hoppers are all acceptable segregation prevention systems. Splitter systems, or a series of baffles, may be used providing they are approved by the City's Representative.

Silos shall be cylindrical with conical bottoms providing a minimum angle of 55° and maximum angle of 70°. The gate opening in the bottom shall be sized to work with the angle of the cone to prevent center draw down resulting in material segregation.

Heated or insulated surge silos are not required, however, a heated discharge cone is preferred.

The asphalt mixture that develops lumps, hardening or chills below 250° (120°C) while the mix heats the silo and discharge cone shall not be used. All surge silos shall be emptied of mix at the end of each production day.

Storage silos shall be well insulated and equipped with heated discharge cones and well sealed discharge gates. Dense-graded asphalt may be stored up to forty-eight hours in silos with heated cones, and seventy two hours with heating of the silo vertical walls and cone.

Storage silos may be used for storage or surge purposes, but under no circumstance may a surge silo be used for storage. Either silo must be equipped with high and low indicator systems.

4.5.15 SHIPPING ASPHALT MIXTURES. Trucks used for hauling mix shall have tight, clean, smooth beds which are treated to prevent the mix from adhering to the bed. Amounts of solution that form visible pools in the truck bed shall be removed prior to loading asphalt mix.

Asphalt mix shall be deposited in a mass into the haul truck or loading hopper from the silo. The gates on the bottom of the silo cone shall open and close quickly. To prevent segregation, it is also necessary for the gates to open completely so that the flow of mix is unrestricted. The mix shall be delivered in evenly divided drops into the length of the truck bed. In no case shall the truck be loaded continuously by the truck driver moving forward under the silo as the mix is being discharged. Multiple drops of small quantities or dribbling mix into the haul vehicle at the end of the main delivery should be avoided to prevent segregation.

4.5.16 SURFACE PREPARATION FOR ASPHALT OVERLAYS. Prior to placing asphalt overlays, all manholes, utility covers, monuments and other items affected by the paving operations shall be located, referenced and protected. The existing asphalt surface shall be thoroughly cleaned of all deleterious materials and brought to a uniform grade by spot leveling or by the application of a bituminous leveling course to the surface. A bituminous tack coat shall be applied to the existing prepared surface immediately prior to placing the finish asphalt course in accordance with Section 4.5.9 of these specifications.

4.5.17 ADJUSTMENT OF MANHOLE AND UTILITY COVERS. Prior to paving and after roadbase is placed, all manholes and utility covers shall be brought to the base grade. Damaged valve boxes, covers, grade rings, cones, flattops, risers, etc. replaced.

Manhole cones or flattops that are more than eighteen inches below finish grade shall be raised by using risers etc. under the cone or flattop. Existing roadbase shall not be contaminated with soil or subbase. Backfill material around adjusted manholes and utilities shall comply with roadbase standards meeting Section 4.5.7 of these specifications, and be compacted to ninety five percent as determined by ASTM D-1557-78 or AASHTO T-180 Method D. When paving is complete, all manhole and utility covers shall be raised to finished grade, including concrete collars, in accordance with standard requirements.

4.5.18 ASPHALT PAVING EQUIPMENT. A self-propelled paver with a screed unit that provides a smooth, steady pull on the screed arms shall be used. The screed unit shall strike off, partially compact, and iron the surface of the mat at least twelve feet (3.7 m) wide. The screed unit shall be equipped with automatic controls and heaters and vibrators. The screed plate must be smooth and not excessively worn. All screed extensions shall be ridged, or hydraulically extendable. The screed extensions shall maintain the proper elevation and angle of attack to the main screed at all times and shall also be heated and provide vibration. Augers shall adequately feed all areas of the extended screed.

The automatic screed controls shall be full contact electronic or non-contact ultrasonic grade control systems. These systems shall be adaptable to a floating-beam system a minimum of thirty feet long. The floating-beam shall be equipped with shoes that are allowed to rotate and can be individually displaced by isolated disruptions in the existing surface without changing the height of the whole beam. The automatic grade sensor shall be set at the midpoint of the floating beam.

Ultrasonic grade control systems may be used without the floating beam on all Traffic Category II streets unless otherwise directed. The ultrasonic grade control system must meet the following conditions in order to be used without the floating beam.

4.5.18.1 The system shall be equipped with a “self diagnostic” function that continuously monitors all system functions and shuts the system down if an error in the system occurs. It shall also be equipped with a “reference bail” to electronically compensate for differences in air and ground temperature with a minimum operating range not less than zero to 160 degrees F. (-18 to 71 degrees C.).

4.5.18.2 The system shall perform to a minimum of the following specifications:

Ultra sonic grade controller:

- On-grade tolerance ±0.01 foot
- Resolution 0.001 foot
- Operating range 10 in. to 42 in.
- Mat thickness control - 0.01 foot

Slope controller:

- Correction window - 1.0%
- On-grade tolerance - 0.1%
- Resolution - 0.01%
- Operating range ±0.0% to 100%.

The systems meeting the above requirements must be properly installed on a “tight,” properly maintained self-propelled paver with a screed unit. A “tight” system shall meet the equipment manufacturer's service specification tolerances for all controlling surfaces and connecting points that affect the ability of that specific type of equipment to provide proper grade control.

The City’s Representative has the right to prohibit the use of such equipment if in his opinion the equipment has not been properly maintained or is not being properly operated.

If the automatic grade control becomes inoperative, the Contractor may finish the day's work using manual controls provided the required grade, thickness and smoothness tolerances are met. Paving shall not continue on the project, or any new project, until the automatic control system has been repaired.

4.5.19 ROLLERS. Rollers shall be vibratory, steel-wheeled double-drum with a static weight of not less than 10 tons (9.10 tonnes) for breakdown rolling. Pneumatic-tired rollers with a minimum operating weight of two thousand pounds (907 kg) per tire shall be used for intermediate rolling and leveling course compaction. The roller shall be in good condition, and capable of reversing without backlash. The number of rollers shall be sufficient to compact the asphalt mixture before it cools below 175°F (80°C). Finish rolling may be performed with the breakdown roller in the static mode, or with a steel-wheeled roller of sufficient size to remove the roller marks in the finished surface. If a roller breaks down and a back-up roller is not available, paving operations shall stop until adequate rollers are available.

4.5.20 WEATHER AND DATE LIMITATIONS. Asphalt shall not be placed during the period from December 1st through February 15th unless otherwise approved by the City Engineer. Paving approved during this time shall conform to winter paving requirements and policies. Minor repairs and patching will be allowed during winter months.

The asphalt mixture shall not be placed upon any wet surface, or when the air and surface temperature of the underlying course is less than specified in Table 4.8. The temperature requirements may be modified, but only when so approved and directed by the City Engineer. Open-graded asphalt mix shall be placed only when the air temperature is 70°F (21°C) and rising, and the surface temperature is a minimum of 60°F (16°C). Air and roadbed temperature shall be measured in the shade. Asphalt mixtures shall not be placed during adverse weather conditions such as rain, wind, hail, etc.

**TABLE 4.8
CLIMATE LIMITATIONS**

Mat Thickness Wind of 5 MPH or less	Minimum Air and Surface Temperature	
	F	C
3 inches or greater	40°	4°
Greater than 2 inches, but less than 3 inches	45°	7°
2 inches or less	50°	10°
Open graded asphalt mix	70 ⁰	21 ⁰

4.5.21 SPREADING AND FINISHING. The asphalt mix shall be placed upon an approved surface, by a self-propelled paver meeting the requirements in Section 4.5.18. The travel rate of the paving machine shall be regulated to a speed dependent upon the capacity of the mixing plant and/or trucking service to supply the mixture. The paving machine shall be operated so that material does not accumulate and cool below 250° F (121°C) along the sides of the receiving hopper.

Where unavoidable obstacles make the use of mechanical spreading and finishing equipment impracticable, the mixture may be spread, raked with hand tools, and mechanically compacted. For such areas, the mixture shall conform to the required mix design, density, compacted thickness, grade and cross section.

The asphalt mix may be windrowed in front of the self-propelled paver properly equipped to transfer the asphalt mix directly into the hopper, provided that the following conditions and requirements are strictly adhered to.

4.5.21.1 The windrow is properly sized, thereby insuring the delivery of the correct amount of material to the paving machine at all times.

4.5.21.2 The asphalt mixture shall be transferred from the windrow to the paving machine in such a manner that the materials in the paver will be a uniform mixture. The base, upon which the windrow was formed, shall not be disturbed. There shall be a minimum amount of asphalt mixture remaining on the base between the pickup device and the paving machine.

4.5.21.3 The material in the hopper of the paving machine shall meet with the temperature requirements. Asphalt mixture that does not meet the minimum specified temperatures shall not be used, and shall be properly disposed of.

When it is determined by the City Representative that the asphalt course being placed by use of a windrow is inferior to that being placed by direct transfer of the asphalt from the hauling vehicle to the spreading machine, the use of the windrow method shall be discontinued.

The asphalt mixture placed by the use of a paving machine during one day's operation shall come from a single plant manufacturer. Intermixing from more than one source shall not be allowed. Intermixing is defined as when more than one plant is used as a routine supply source to a single operation.

The asphalt mixture shall have a temperature not less than 270°F (132°C) nor more than 325°F (163°C), at the time the paving machine places the asphalt mixture on grade. Depending on environmental conditions and compaction requirements, the City's Representative may specify more strict temperature requirements.

Asphalt pavement courses of more than three inches in total compacted thickness shall be placed in two or more courses. One course shall not be placed over another course until the compaction requirements have been met and the mat temperature has cooled to 160°F (71°C) at mid-depth.

Placing of the asphalt pavement shall be as continuous as possible. Rollers should not pass over the unprotected edge of the freshly laid asphalt mixture. Transverse joints shall be formed by cutting back on the previous run to expose the full depth and proper grade of that course. A tack coat meeting Section 4.5.9 of these specifications shall be applied on the contact surface of the prepared transverse joints just before the new asphalt mixture is placed.

Longitudinal joints shall be spaced in such a manner that joints in succeeding courses will be offset at least twelve inches horizontally from joints in any preceding course. Lanes will be evened up each day to minimize cold longitudinal joints and to provide proper transverse joints. Where possible, the top course longitudinal joints shall be placed a minimum of one foot either side of the lane line.

Transverse joints shall be spaced in such a manner that joints in succeeding passes will be a minimum of five feet horizontally from joints in any adjacent pass.

Existing roadway pavements to be widened shall be sawcut far enough into the roadway to provide the proper grade, cross-section and thickness with a straight vertical longitudinal or transverse joint. These joints shall have a tack coat meeting Section 4.5.9 of these specifications applied on the contact surface immediately prior to paving.

Longitudinal joints on previously compacted passes should have an overlap of new asphalt mixture one to one and one-half inches over the existing mat. Raking should be merely to "bump" the joint, pushing the asphalt mixture off the previous pass and onto the new pass directly over the joint. If the adjacent mat is overlapped too far and too much asphalt mixture is deposited on the existing mat, the excess material shall be pulled away from the new mat rather than being pushed onto the new mat. Excess mix shall

never be broadcast across the newly laid asphalt. The excess mix shall be picked up and recycled.

4.5.22 ROLLING AND COMPACTING. Compaction equipment shall meet the requirements of Section 4.5.19 of these specifications, unless otherwise approved or required by the City's Representative.

A pass shall be one movement of a roller in either direction. A coverage shall be as many passes as are necessary to cover the entire width being paved. Overlap of passes during any coverage, made to ensure compaction without displacement of material shall be in accordance with good rolling practice.

The breakdown rolling shall consist of one or more complete coverages of the asphalt mat with a vibratory steel-wheeled roller. Initial rolling shall commence at the lowest edge and shall progress toward the highest portion of the asphalt mat. Initial rolling shall not commence on the interior portion of any mat.

The breakdown rolling shall be followed immediately by additional rolling with a pneumatic-tired roller that will provide uniform density throughout the depth of the course being compacted. A minimum of two rollers, one steel-wheeled, and one pneumatic-tired, shall be used. However, the total number of rollers used beyond the minimum of two shall be sufficient to obtain the required compaction while the asphalt mixture is above 175°F (80°C).

The final rolling of the asphalt mixture shall be performed by a steel wheel roller of sufficient size to remove all roller marks caused during the compaction of the asphalt mixture. The vibratory roller used for breakdown rolling may be used as the finish roller provided it is operated with the vibratory unit turned off.

The rollers shall be kept in continuous motion while rolling so that all parts of the asphalt mixture will receive as close to equal compaction as possible. The roller speed shall be slow enough at all times to avoid displacement of the pavement. Any displacement occurring as a result of reversing the direction of the roller, or from any other cause, shall be corrected immediately by use of rakes and fresh asphalt mixture when required.

To prevent adhesion of the asphalt mixture to the rollers, the wheels/tires, bars, pads and release agent pumps shall be kept properly maintained. The use of diesel oil on pneumatic-tired rollers shall be kept to a minimum and used only in conjunction with coca pads to prevent the asphalt mixture from adhering until the tires heat enough to prevent mix adherence.

The completed surface shall be thoroughly compacted, smooth and free from ruts, humps, depressions, or irregularities. Any ridges, indentations or other objectionable marks left in the surface of the finished pavement shall be eliminated by rolling or other means. The use of any equipment that leaves ridges, indentations, or other objectionable marks in the asphalt surface shall be discontinued, and acceptable equipment shall be furnished.

Compacting the longitudinal joint shall be performed by placing the roller on the hot uncompacted mat and overlapping the joint by a distance of approximately six inches over the cold compacted mat. For proper compaction, the level of the uncompacted mix at the longitudinal joint must be above the elevation of the compacted mix by an amount equal to one-quarter inch for each one inch of compacted pavement. This ratio is “rule of thumb” and may vary slightly depending on the type of asphalt mix and the supplier. A test strip is advisable.

A good source of information for rolling asphalt is a document by AASHTO, FAA, Federal Highway Administration and the National Asphalt Pavement Association entitled "AC 150/5370-14, Appendix 1, July 31, 1991". The following information is taken from that document.

1. Rolling From The Cold Side - It was common practice in the past to do the initial rolling of the longitudinal joint from the cold (previously placed mat) side of the joint. The major portion of the weight of the roller was supported by the cold, compacted mat. Only six inches or so of the width of the roller hung over the fresh mat, compressing the mix along the joint. The majority of the compactive effort was wasted because the roller essentially was applying its compactive effort to an already-compacted asphalt material.

During the time that the roller was operating on the cold side of the longitudinal joint, the mix on the hot side of the joint, and the rest of the mix in the course being laid, was cooling. Depending on the environmental conditions and the thickness of the mix being placed, the process of compacting the joint from the cold side often proved to be detrimental to the ability to obtain density on the whole pavement layer.

The reason often given for rolling the joint from the cold side of the joint was that this compaction method allowed the rollers to "pinch" the joint and obtain a higher degree of density. There is no evidence that this is true.

2. Rolling From The Hot Side - The most efficient way to compact the longitudinal joint is to put the roller on the hot mat and overlap the joint by a distance of approximately six inches over the cold mat. This places the majority of the weight of the compaction equipment where it is needed. The mix at the joint is still pushed into the joint area by the roller as long as the elevation of the new mix at the joint is proper. The longitudinal joint can be compacted effectively by keeping the roller on the new mix, instead of on the previously compacted mix. Any type of roller used for the breakdown rolling of the mix can be employed to compact the longitudinal joint as long as the elevation of the mix at the joint is above the level of the cold mat and the mix is still hot.

Sometimes the first pass of the roller is completed with the edge of the machine about six inches inside of the longitudinal joint. The theory behind this method of compaction is that the mix will be shoved toward the joint by the roller, and better compaction will be obtained. If the mix being placed is stable enough, the roller should not be able to move the material laterally to any significant degree. If the mix design is proper, this method of compacting the joint does not provide any advantage over moving the first pass of the roller outward one foot (from six inches inside the joint to six inches outside the joint). Rolling the mat by lapping the roller over the adjacent old pavement typically is the more efficient way to provide roller coverage for the whole pavement width.

4.5.23 OPEN-GRADED WEARING COURSE.

4.5.23.1 WEARING COURSE. An open-graded wearing course shall be placed over a dense-graded asphalt course. The dense-graded asphalt shall be true to line and grade, cleaned and tacked.

The following specifications shall be complied with:

<u>Item</u>	<u>Section</u>
Dense-graded asphalt	4.5.10
Tack Coat	4.5.9
Asphalt Cement for (existing road) Overlays	Table 4.10
Asphalt Cement for New Construction	4.5.10.2
Hydrated Lime	4.5.11
Other related requirements	

Aggregate gradation shall conform to Table 4.9 when tested under AASHTO T-30.

The percent passing the No. 200 (.075 mm) sieve will be determined by using AASHTO T-11, test procedures.

That portion of aggregate retained on the No. 4 (4.75 mm) sieve shall have no more than ten percent rounded particles when tested in accordance with UDOT Test Procedure 8-929.

TABLE 4.9 OPEN-GRADED ASPHALT AGGREGATE GRADATION			
SIEVE SIZE		IDEAL GRADATION PERCENT PASSING	IDEAL GRADATION TOLERANCE
AMERICAN	METRIC		
½ inch	12.5 mm	100	0
3/8 inch	9.5 mm	96	93-100
No. 4	4.75 mm	40	35-45
No. 8	2.36 mm	17	13-21
No. 200	.075 mm	3	1.3-4.7

**TABLE 4.10
RUBBERIZED LIQUID ASPHALT REQUIREMENTS**

AC-20R:			
Property	ASTM	Specification Min. Max.	
Viscosity @ 140°F, poise	D-2171	1,600	2,400
Viscosity @ 275°F, cs	D-2170	325	
Pen @ 77°F (100 g, 5 sec)	D-5	70	
Flash Point, °F, C.O.C.	D-92	450	
Duct. @ 39.2°F, (5 cm/min)	D-113	50	
cm		2.0	
Rubber, weight %	*	110	
Toughness, in-lb	*	75	
Tenacity, in-lb	D-2872		
Rolling Thin-Film Oven Test	**		
Tests on Residue:		8,000	
Viscosity @ 140°F, poise	D-2171		
Duct. 39.2°F, (5 cm/min)	D-113	25	
cm			
<p>* Benson Method of Toughness and Tenacity: Scott Tester, inch-pounds @ 77°F, 20 inches per minute pull. Tension head 7/8-inch diameter.</p> <p>** TFOT ASTM D-1754 may be used. The Rolling Thin-Film Circulating Oven Test is the preferred method.</p>			

4.5.23.2 SUITABILITY OF AGGREGATE. The following requirements shall be used to determine the suitability of the aggregate during the mix design:

- Wear shall not exceed thirty percent when tested in accordance with AASHTO T-96.
- The weighted loss shall not exceed twelve percent by weight when subjected to five cycles of sodium sulfate tested in accordance with AASHTO T-104.
- Aggregates consisting mainly of carbonate type rocks shall not be used unless approved by UDOT as satisfactory long-term friction values for comparable traffic volumes when tested in accordance with AASHTO T-242 or ASTM E-274-79.

Aggregates shall be separated into two or more sizes and stored separately.

Stockpiling or handling methods that cause segregation, degradation or the combining of materials of different sizes when placing the aggregate in storage or moving it from storage to the cold bins shall not be used. Any segregated or degraded material shall be re-screened.

4.5.23.3 MIX DESIGN. Annual mix designs shall be submitted in writing to the City Engineer for approval two weeks prior to the first job each calendar year, or upon selection of new aggregate sources. Any revisions to the approved mix design shall fall within the requirements listed above. Open-graded wearing courses that do not meet the tolerances shown in Section 4.5.24 shall be removed and replaced with material meeting the required gradation. The asphalt cement shall be within 0.10 percent of the mix design. At no time shall the asphalt cement content be such that asphalt slicks form on the surface of the roadway.

Based on the mix design, the open-graded wearing course shall have a tensile strength ratio of seventy (70) percent, or greater, in accordance with AASHTO T-283 UDOT modified. Hydrated lime or anti-stripping agent may be added to the asphalt mix to meet the minimum tensile strength of seventy (70) percent.

4.5.23.4 MIXING. The mixing shall be done as specified in Section 4.5.13. The mineral aggregate will be considered satisfactorily coated with asphalt when all particles are coated. During mixing the viscosity of asphalt shall be maintained between four hundred and nine hundred centistokes. The viscosity of polymer-modified asphalt, when used, shall be maintained between one hundred fifty and three hundred (150-300) centistokes.

If a drier-drum mixing process is used, the temperature of the mixture shall not be less than 220°F (104°C), or more than 275°F (135°C), when discharged from the mixer. When using a polymer-modified asphalt the temperature of the mixture when discharged from the mixer, shall be maintained between 270°F (132°C) and 320°F (160°C). Viscosity will be determined in accordance with ASTM T-201.

4.5.23.5 SURFACE PLACEMENT. Tack coat shall be applied in accordance with Section 4.5.9.

Self-propelled asphalt paving equipment and automatic screed controls meeting the requirements of Section 4.5.18 shall be used. Rollers shall meet the requirements of Section 4.5.19 and shall be a ten ton (9.10 tonne) vibratory operated static or a ten ton (9.10 tonne) static steel wheeled roller for asphalt pavement finishing.

Paving operations should be planned such that all passes will be brought even “transversely” at the end of each working day. Joints between old and new pavements, or between successive days works shall ensure continuous bond

between adjoining work. Construct joints to have the same texture, density, and smoothness as other sections of the bituminous pavement course. Clean contact surface and apply tack coat.

Offset longitudinal joints a minimum of 12 inches in succeeding courses and at least 6 feet transversely to avoid vertical joints through more than one course. In the top course restrict longitudinal joint to 1 foot either side of the lane line. Prevent traffic, including construction traffic, from crossing vertical joint edges.

Excessive rolling shall not be allowed. Wearing course compaction shall be completed prior to the mix temperature drop below 180°F (82°C). When using polymer-modified asphalt, compaction shall be completed prior to the mix temperature dropping below 200°F (93°C).

Asphalt slicks shall be raked immediately. Slick spots that cannot be removed by raking, shall be replaced. All humps or depressions exceeding tolerances shall be corrected. Correction methods shall be approved by the City's Representative.

All traffic shall be prevented from traveling on the completed wearing course until it has hardened sufficiently and the surface temperature has dropped below 160°F (71°C). The thickness of the compacted wearing course shall not vary more than one-quarter inch (6.35 mm) from the specified thickness. Testing and acceptance shall conform to Section 4.5.24.

4.5.24 ACCEPTANCE TESTING REQUIREMENTS AND TOLERANCES. The following subsections list the requirements for testing and acceptance for subbase, roadbase, RAM, dense-graded asphalt, open graded asphalt and asphalt pavement surfaces. Testing documentation shall fully address the requirements of these standards.

4.5.24.1 SUBBASE. The following will be required for testing and acceptance of subbase:

- A. One moisture/density test per seven thousand square feet of roadway, or fraction thereof.
- B. One thickness test hole per five thousand square feet.
- C. One gradation test per fifteen thousand square feet of roadway, or fraction thereof. The allowable deviations from the approved subbase targets are as follows:

SIEVE SIZE AMERICAN (METRIC)	ALLOWABLE DEVIATION
2" (50.80 mm) to 6" (152.4 mm)	± 12.1%
½" (12.5 mm) to 1" (25.0 mm)	± 10.8%
3/8" (9.5 mm)	± 9.8%
No. 4 (4.75 mm)	± 8.8%
No. 16 (1.18 mm)	± 6.9%
No. 200 (.075 mm)	± 2.9%

C.1 One sand equivalent (*SE*) value for every gradation outside the allowable deviation. A CBR or R-value shall be performed on twenty five percent of all sand equivalent test results with a minimum of one test required. Where multiple SE tests are run, the CBR or R-value shall be determined on those SE tests that exhibit the lowest values.

The Following Are the Minimum Values for Roadway Subbases.

- The minimum acceptable SE value shall be eighteen.
- The minimum acceptable R-value shall be sixty.⁽¹⁾
- The minimum acceptable CBR value shall be 8.8.⁽²⁾

Note 1: R-value test: AASHTO T-190 or ASTM-D 2844 (300 psi exudation pressure)

Note 2: CBR Value Test: AASHTO T-193, (3 point)

4.5.24.2 ROADBASE AND RECYCLED AGGREGATE MATERIALS (RAM).

- A. One moisture/density test per seven thousand square feet of roadway, or fraction thereof.
- B. One thickness test hole per five thousand square feet.
- C. One gradation test per fifteen thousand square feet of roadway, or fraction thereof. The allowable deviation from the approved roadbase and RAM targets are as follows:

SIEVE SIZE AMERICAN (METRIC)	ALLOWABLE DEVIATION
½" (12.5 mm) to 1" (25.0 mm)	± 10.8%
3/8" (9.5 mm)	± 9.8%
No. 4 (4.75 mm)	± 8.8%
No. 16 (1.18 mm)	± 6.9%
No. 200 (.075 mm)	± 2.9%

C.1 One sand equivalent (*SE*) value for every gradation outside the allowable deviation. A CBR or R-value shall be performed on twenty five percent of all sand equivalent test results with a minimum of one test required. Where multiple SE tests are run, the CBR or R-value shall be determined on those SE tests that exhibit the lowest values.

The Following Are the Minimum Values for Roadbase and RAM.

- The minimum acceptable SE value shall be twenty-two.
- The minimum acceptable R-value shall be seventy-six.⁽¹⁾
- The minimum acceptable CBR value shall be 14.5.⁽²⁾

Note 1: R-value test: AASHTO T-190 or ASTM-D 2884 (300 psi exudation pressure)

Note 2: CBR Value Test: AASHTO T-193, (3 point)

4.5.24.3 DENSE-GRADED ASPHALT PAVEMENTS.

- A. One density test per seven thousand square feet of surface area, or fraction thereof.
- B. One core sample per nine thousand square feet, or fraction thereof, unless sufficient inspection has been made by the City's Representative to verify required thickness.
- C. One extraction and gradation test per days work, or one for every five hundred tons or fraction thereof, whichever is greater.

In the event that the asphalt pavement fails to meet the allowable deviation for extraction or gradation tests, or shows a tendency under traffic loading to rut, tear, or distort, or in the opinion of the City's Representative is "tender" or deficient in appearance, the asphalt pavement shall be cored

and tested in accordance with AASHTO T-283-89 or ASTM D 4867-92 including Note 5.

The asphalt pavement must possess seventy percent of the tensile strength ratio based on the approved Marshall mix design. Asphalt pavement not meeting this requirement shall be removed.

The maximum allowable deviations from the approved Marshall mix design are:

Asphalt content	+/- 0.46%	
½" (12.5 mm) and larger	+/- 6.3%	
3/8" (9.5 mm)	+/- 5.9%	
No. 4 (4.75 mm)	+/- 5.7%	
No. 8 (2.36 mm)	+/- 4.8%	
No. 16 (1.18 mm)		+/- 4.6%
No. 50 (.300 mm)		+/- 3.8%
No. 200 (.075 mm)	+/- 2.0%	

4.5.24.4 COMPACTION OF DENSE-GRADED ASPHALT PAVEMENT.

A. Acceptance of dense graded asphalt pavement shall be as follows:

- When the average of all density tests is not less than ninety six (96) percent of the maximum laboratory density (Marshall) and when no single test is lower than ninety two (92) percent of the Marshall.
- When the average of all density testing falls between ninety three (93) percent to 95.9% of the Marshall with no test lower than ninety two (92) percent of the Marshall, the asphalt pavement shall be tested to determine the percent of air voids. If the percent of air voids are between three to five (3-5) percent, the asphalt pavement will be considered acceptable. If the percent of air voids are between five to seven (5-7) percent, the asphalt pavement will require a slurry seal per these specifications.
- When the average of all density testing falls between ninety one (91) percent of the Marshall and 92.9% of the Marshall with no single test below ninety (90) percent of the Marshall, the asphalt pavement shall be overlaid with a minimum of one inch thick asphalt pavement. Prior to the overlay, the existing asphalt next to the curb, gutter, cross gutter, etc. shall be milled one inch below the top edge of the concrete to provide a finished asphalt surface that is flush with or not more than .02 foot above the concrete gutter.
- Asphalt pavements with an average density less than ninety one percent of the Marshall, or with any single test less than ninety percent of the Marshall, shall be removed and replaced.

4.5.24.5 OPEN-GRADED ASPHALT WEARING COURSE.

In the event that the extraction or gradation fails to meet the allowable deviation, the remaining sample material shall be remolded and tested in accordance with AASHTO T 283-89 or ASTM D 4867-92 including Note 5. The open-graded asphalt pavement must possess seventy percent of the tensile strength ratio based on the approved mix design. Open-graded asphalt not meeting this requirement shall be removed and replaced.

The allowable maximum deviations from the approved Marshall mix design shall be as follows:

Asphalt content	+/- 0.46%
½" (12.5 mm)	+/- 6.3%
3/8" (9.5 mm)	+/- 5.9%
No. 4 (4.75 mm)	+/- 5.7%
No. 8 (2.36 mm)	+/- 4.8%
No. 200 (.075 mm)	+/- 2.0%

4.5.24.6 ASPHALT PAVEMENT SURFACES.

The completed surfacing shall be thoroughly compacted, smooth and free from ruts, humps, depressions, rock pockets or slick spots. Any ridges, indentations or other objectionable marks left in the pavement's finished surface shall be corrected prior to acceptance.

The paving contractor shall provide adequate quality control during spreading and finishing procedures to meet or exceed the following longitudinal and transverse profiles:

- Longitudinal deviations shall not exceed ± 0.025 foot in 25 feet when checked by a taut string line.
- Transverse deviations shall not exceed ± 0.01 foot in 10 feet when checked with a ten foot straight edge.
- Longitudinal construction joint deviations shall not exceed ± 0.01 foot when checked with a ten foot straight edge.
- The completed pavement surfaces shall be constructed to the required grades and cross sections. When pavement surfaces contact concrete structures such as drainage structures, curbs & gutters, utility vaults, or manholes, the pavement surfaces shall be flush with or above the concrete structures by not more than 0.02 foot.

All deviations exceeding the specified profile tolerances shall be corrected prior to final rolling.

4.6 BITUMINOUS SEAL COAT (CHIP SEAL). Bituminous surface treatments (chip seals) shall be applied to the road surface only when required, or approved by the City Engineer. The bituminous surface treatment shall consist of an application of bitumen covered with mineral aggregate and rolled to a smooth surface presenting an even texture. The materials used in the application of the bituminous surface treatment shall be bituminous mineral, and mineral aggregate, as specified below.

4.6.1 MATERIAL SPECIFICATIONS.

4.6.1.1 BITUMINOUS MATERIAL. The bituminous material shall be cationic emulsified asphalt with a natural latex rubber material (type LMCRS-2H) and shall conform to the following requirements:

TEST	SPECIFICATION	PARAMETERS
Viscosity @ 122° F. Sieve Settlement, 5 days Demulsibility Storage Stability (1 day test) Ash Content	AASHTO T-59 AASHTO T-59 AASHTO T-59 AASHTO T-59 AASHTO T-59 ASTM D3723	100-300 sec. 0.3% max. 5% max. 40% min. 1% max. 0.2% max.
Tests on Residue by Drying: Percent Residue Penetration @ 77° F., (100 g., 5 sec.) Ductility @ 77° F., (5 cm./min.) Torsional Recovery	NV 756 AASHTO T-49 AASHTO T-51 NV 756	65% min. 40-150 mm. 40 cm. min. 18% min.
Particle Charge	AASHTO T-59	POSITIVE

4.6.1.2 AGGREGATE (CHIPS). Mineral aggregate shall consist of crushed stone or crushed gravel, free from adherent films of clay or dust, and shall be of such nature that a thorough coating of the bituminous material used in the work will not strip off upon contact with water.

The gravel or rock shall have a percent of wear not greater than thirty when tested by the Los Angeles Abrasion Test (AASHTO T-9 ASTM C 131).

Chips shall be cubical or pyramidal in shape with at least ninety-five (95) percent fractured faces. The crushed aggregate shall have a weighted percent of loss not exceeding ten percent by weight when subjected to five cycles of sodium sulfate and tested in accordance with AASHTO Designation T-104.

Stripping tests of the mineral aggregate which the Contractor proposes to use shall be furnished to the City’s Representative before crushing operations begin. During aggregate crushing, additional stripping tests shall be furnished to the City’s Representative upon request. No stripping test shall show a percent stripping greater than ten for LMCRS-2H asphalt. The chip shall be electrically compatible to the asphalt emulsion used.

The crushed aggregate shall conform to the gradation requirements shown in following table.

**TABLE 4.11
GRADATION OF AGGREGATE FOR CHIP SEAL COATS**

SIEVE SIZE	PERCENT BY WEIGHT PASSING (Ideal)	IDEAL GRADATION TOLERANCE (Percent)
1/2 Inch	100	0
3/8 Inch	95	+/- 5
No. 4	10	+/- 5
No. 8	2	+/- 2
No. 200	0.5	+/- 0.5

The initial mineral aggregate used for the production of chips shall be retained on a one-inch sieve prior to being crushed to the gradation specified.

4.6.2 AGGREGATE QUALITY CONTROL. Prior to delivery to the project site the designated wear test, striping test, sodium sulfate test, fracture face count, and gradation tests shall be performed on the crushed aggregate. Each time a source changes said tests will be repeated.

All aggregate (chips) shall be tested for compliance with the gradation and fracture face count during the production of the chips. There shall be no less than one test performed for every five hundred tons of material produced or one day’s production, whichever is less. One gradation test and fracture face count test shall be defined as the average results of tests taken on three different samples taken at one particular time.

All material produced shall be stockpiled in designated stockpile site(s).

When chips are delivered to the project stockpile site there shall be one gradation test conducted for every five hundred tons of material. If the gradation test requirements are not met, the City’s Representative may require that the failed material be removed from

the stockpile. Chips shall be considered to be out of specification if one test (as defined herein above) fails.

The City's Representative will not accept any chips which do not meet all the designated specifications. No reduction in pay or other remedial terms will be allowed or negotiated.

In addition to the random acceptance samples taken at the stockpile, the City's Representative may sample the aggregate from any portion of stockpile which exhibits a non-uniform appearance.

The Contractor shall take immediate steps to bring the aggregate into specifications when test results show any deviation from the established maximum or minimum values for any sieve as shown in Table 4.11 of these specifications.

At designated stockpile site(s), the Contractor may be required to "push up" the unloaded aggregate into piles suitable for loading into the delivery dump trucks.

Extreme care shall be taken so as not to mix any of the crushed aggregate with the underlying material at the stockpile or the crushing site. In the event that there is contamination of the chip seal aggregate with foreign material, as determined by the City's Representative, or by tests conducted, the contaminated section of material shall be immediately removed from the stockpile or crushing area and properly disposed of. All contaminated material removed from the stockpile, or crushing area, shall be replaced with aggregate which meets the requirements of these specifications.

All testing required by the City's Representative, or by the plans and specifications, shall be performed by an independent testing laboratory. The Contractor shall do everything in his power to ensure that the City's Representative has full access to the testing procedure and shall deliver to the

City's Representative any and all results of tests run. The Contractor shall not proceed with subsequent construction until certified copies of appropriate tests are delivered to the City's Representative. Any materials not properly tested shall be subject to rejection and removal.

4.6.3 EQUIPMENT. All tools, equipment and machines used in the performance of the work shall be subject to the approval of the City's Representative, and shall be maintained in satisfactory working conditions at all times.

4.6.3.1 ASPHALT DISTRIBUTOR. The asphalt distributor shall be equipped with a calibrated dipstick marked in gallons per inch of length, and an accurate thermometer and speedometer. The distributor shall also be capable of maintaining proper pump pressure to ensure a uniform distribution of liquid asphalt emulsion at all times. The pump shall be able to maintain the correct pump speed, or pressure, without either atomizing the asphalt or distorting the spray fan. However, the pump shall be able to maintain a pressure which shall be

sufficient to prevent streaking from a non-uniform discharge of material from the individual nozzles.

The distributor shall be equipped with a rear-mounted spray bar capable of covering widths of six to fifteen feet in a single pass. The distributor tank shall be well insulated and be equipped with one or more heaters capable of bringing the asphalt emulsion to spray application temperature. The tank shall have a full circulating system which shall include the spray bar unit. The truck shall also be equipped with a hand-spray for applying the asphalt emulsion to areas that cannot be reached with the spray bar.

The distributor shall be equipped with a computer which will automatically determine the discharge based on the nozzle size, the truck speeds for various application rates, and the corrections for temperature-viscosity variations.

4.6.3.2 AGGREGATE SPREADER. The spreader shall be a self-propelled Flarity chip spreader, or equal, capable of uniformly spreading aggregate at varying application rates as required. The spreader shall be equipped with a tachometer and/or a speedometer to ensure the maintenance of a uniform spreader speed. The aggregate spreader shall also be equipped with a device and so operated that the coarse particles of the screening shall be deposited on the bituminous binder before the finer particles.

4.6.3.3 ROLLERS. The Contractor shall provide at least two self propelled, smooth-tread, pneumatic tired rollers on the job during the chipping operations. Each roller shall weigh at least ten-tons and have staggered (offset) front and rear tires to obtain a uniformly rolled pass. Tire pressure in all tires shall be uniform and inflated to eighty psi. No steel wheel rollers shall be used to roll the chip seal surface treatments. Rolling speed shall not exceed ten miles per hour.

4.6.3.4 DUMP TRUCKS. The Contractor shall provide sufficient ten-wheel dump trucks during the chip sealing operations to ensure that the project can proceed without interruption. **FREQUENT STOPS AND STARTS DURING THE CHIP SEAL OPERATION WILL NOT BE PERMITTED.**

4.6.3.5 FRONT END LOADERS. The Contractor shall have on hand at least one front end loader to load the aggregate into the dump trucks from the aggregate stockpile(s). The loaders shall have at least a two-and-one-half yard capacity bucket.

4.6.3.6 POWER BROOMS. The Contractor shall provide at least one self-propelled rotary power broom or sweeper at the job site, and shall use said sweeper (supplemented with hand brooms as necessary) as required, to sweep the excess aggregate on the edge of each pass which will be in contact with the next pass so that there will be no build up of aggregate at the seams or joints between passes. The broomed aggregate shall be swept onto the freshly laid course.

4.6.4 BITUMINOUS CHIP SEAL CONSTRUCTION METHODS. The methods employed in installing bituminous chip seal(s) shall include, but are not limited to, the following:

4.6.4.1 SURFACE PREPARATION. All dust, dirt, tracked on clay and foreign material shall be removed from the surfaces to be sealed by sweeping the surface with power brooms, hand brooms, power blowers, or by flushing it with water or a combination of the above. All patching, crack filling and drainage improvements required by the City's Representative shall be completed prior to the commencement of the surface treatment application. After the cleaning operation has been completed, and prior to the application of the surface treatment, the area to be treated will be inspected by the City's Representative to determine its fitness for receiving the surface treatment.

All sewer manhole lids, water valve covers and survey monument covers shall be protected from the application of the seal coat by placing building paper over the lids (cut to the exact dimensions of the lids) prior to the application of the seal coat. At the completion of the sealing operations, all protective coverings shall be removed from said survey monument covers, manhole lids and valve covers.

At the edges of all passes which will form longitudinal joints in the surface treatment (chip seal) the edge of the pass shall be swept clean of all chips for a distance of from four to six-inches back from the edge prior to the application of the adjacent pass to allow for overlap without chip buildup (humps) in the previous pass. Building paper shall be laid on all cross gutters (concrete waterways) to prevent the chip seal from being applied to said gutters. The Contractor shall place building paper at the beginning of all chip passes. Immediately after the chip application, the building paper shall be removed and destroyed.

4.6.4.2 ASPHALT APPLICATION. Application of the bituminous material shall not be permitted until the loaded aggregate trucks, rollers, and chip-spreader are in place and ready to apply, and roll, the cover aggregate. No surface will be chip sealed until authorization to do so has been obtained from the City's Representative. The asphalt material shall be applied at 0.32 to 0.40 gallons per square yard or as determined by the City's Representative and at a temperature between 125 degrees to 185 degrees Fahrenheit. The exact temperature used to apply the bituminous material shall be determined by the City's Representative.

The bituminous material shall be applied by an asphalt distributor, as described above, so that uniform distribution in the quantities specified is obtained over all points of the surface to be treated. All lightly-coated areas and spots missed by the distributor shall be properly treated with bituminous material applied by hand. No more asphalt shall be applied than can be covered with aggregate in sixty seconds

or less. Distances between the distributor and chip-spreader shall be as close as possible, but in no case shall the chip-spreader be greater than fifty feet behind the distributor during the chipping operations.

4.6.4.3 AGGREGATE SPREADING. Immediately following the application of the bituminous material, the aggregate shall be evenly spread over the surface at a uniform quantity of twenty-five to thirty (25-30) pounds per square yard of surface area. Upon commencement of the work, and during its progress, the individual quantities of bitumen and aggregate may be varied to meet specific field conditions, as directed by the City's Representative. An adequate supply of aggregate shall be available on the job site to permit continual spreading operations. Aggregate shall be damp (not wet) prior to being spread on the surface. The aggregate shall be spread by using a self-propelled spreader machine (Flarity or equal). The aggregate shall be spread evenly by hand on all areas missed by the aggregate spreader. Back-spotting or sprinkling of additional aggregate over the areas having insufficient cover shall be done by hand and shall be continued during the operations whenever necessary.

As the distributor moves forward to spray the asphalt, the aggregate spreader shall start right behind it, spreading the damp chips uniformly and at the specified rate. The asphalt distributor shall travel at the same rate of speed as the chip spreader and in no case shall the two machines be separated by more than fifty feet during the sealing process. Operating the chip spreader at speeds which cause the chips to roll over after striking the bituminous-covered surface will not be permitted.

Excess aggregate deposited in localized areas shall be immediately removed with square-end shovels, and in areas where application is insufficient, additional aggregate shall be added by hand prior to the time the asphalt "breaks".

4.6.4.4 AGGREGATE COMPACTION. The treated surface shall be rolled with rubber-tired rollers immediately after the distribution of the cover aggregate, and rolling shall continue until the aggregate is properly seated in the binder. Rollers shall proceed in the longitudinal direction, working across the treated surface until the entire width and length of the treated surface has been rolled at least four times. All rolling shall be completed within one hour after the application of the cover aggregate. Rollers and gravel trucks shall not be operated at speeds great enough to kick up chips, and in no case shall rollers be operated above ten miles per hour. In all places not accessible to the rollers, the aggregate shall be adequately compacted with pneumatic type hand tampers. Any aggregate that becomes coated, or mixed with dirt or any other foreign material shall be removed, replaced with clean aggregate over a newly-sprayed surface, and then re-rolled as directed by the City's Representative.

Bituminous material and chips shall not be spread more than one hundred feet ahead of completion of initial rolling operations.

No aggregate will be allowed to be swept into the gutters, onto the sidewalks, or thrown onto private property. The Contractor shall be responsible for the clean up of any and all aggregate swept into these areas.

Prior to placing the second chip seal course on streets designated for double chip seals, the first course shall be thoroughly rolled to set the chips, then no less than 24 hours later the excess chips shall be removed. Upon removal of the excess chips, the second course may be applied.

4.6.4.5. LOOSE AGGREGATE REMOVAL. Upon completion of rolling, traffic will be allowed to use the streets at a speed not to exceed fifteen miles per hour for a period of not less than twenty four hours. After the chips are set in the bituminous binder, but not earlier than the following day, or as directed by City's Representative, loose chips on the surface of the road shall be broomed and removed in such a manner that the aggregate set in the binder will not be displaced. Excessive brooming will not be permitted. At the end of seven days, any excess chips shall be removed in such a manner that the aggregate set in the binder will not be displaced. Excessive rolling or brooming will not be permitted.

4.6.4.6. SANDING. After the surface has been opened to traffic, any excess bituminous material that comes to the surface (bleeds) shall be immediately covered with CLEAN SAND. The Contractor shall be required to have sufficient CLEAN sand (NOT DIRT) on hand or available to immediately sand any bleeding spots when requested by the City's Representative. Sanding shall be accomplished by evenly spreading the sand over the affected area and then hand brooming the sand to a smooth even surface with no bumps, ruts, depressions or irregularities visible.

4.6.4.7. APPEARANCE. The completed chip sealed surface shall present a uniform appearance and shall be thoroughly rolled and compacted and free from ruts, humps, depressions or irregularities due to an uneven distribution of bituminous binder or aggregate. In the event the surface presents an unacceptable appearance, as determined by the City's Representative, the Contractor shall repair unacceptable areas in accordance with the City Representative's directions.

4.6.4.8. WEATHER LIMITATIONS. Chip seal treatments shall be placed only when the air temperature in the shade is above 75 degrees Fahrenheit. The chip seal shall not be placed when the temperature of the road surface is below 70 degrees Fahrenheit, above 120 degrees Fahrenheit, during rainy weather, when the surface is wet or during other unfavorable weather conditions as determined by the City's Representative.

4.7 ASPHALT EMULSION SEAL COAT (SLURRY SEAL). This sub-section covers the requirements for the application of slurry seal coats on existing road surfaces. The slurry seal surface treatment shall consist of a mixture of emulsified asphalt, mineral aggregate, mineral filler, set control additive, and water. The slurry shall be properly proportioned, mixed, and

spread evenly on a prepared surface in accordance with these specifications, or as directed by the City's Representative. When cured, the slurry shall have a homogeneous appearance, fill all cracks, adhere firmly to the road surface, and have a skid resistant texture.

4.7.1 MATERIAL SPECIFICATIONS.

4.7.1.1. ASPHALT EMULSION. The asphalt emulsion shall conform to the specifications outlined in Tables 4.12, 4.13 and 4.14. Either cationic or anionic emulsion may be used, whichever is best suited to the aggregate and job conditions to be encountered, as determined by compatibility tests and procedures as specified in the latest edition of the ISSA Technical Bulletin #115.

4.7.1.2. AGGREGATE. The mineral aggregate shall consist of angular sand, or crushed stone, that is free from dirt, organic matter, clay balls, adherent films of clay, dust or other objectionable matter. When tested according to AASHTO T-176, the aggregate shall have a sand equivalent of not less than forty five (**45**), and the aggregate shall be non-plastic. When tested according to AASHTO T-104, the aggregate shall show a loss of not more than fifteen (**15**) percent, and when tested according to AASHTO T-96, the aggregate shall show a loss of not more than thirty five (**35**) percent. The combined mineral aggregate shall conform to the requirements of type **II or type III** slurry as outlined in Table 4.15.

4.7.1.3. FILLER. The mineral filler shall conform to the requirements of AASHTO M-16 and shall be used to improve the gradation of the aggregate, to provide improved stability and workability of the slurry, and to increase the durability of the cured slurry.

4.7.1.4. SET CONTROL ADDITIVE. To control the setting time of the slurry mixture, an additive shall be added which will retard the set when a cationic emulsion is used, or accelerate the set when an anionic emulsion is used. The set control additive shall be aluminum sulfate or Portland Cement Type I/II, and shall be added to the slurry mix by an approved method that will assure uniform distribution and proper control. The exact amount shall be determined by conditions in the field and as directed by City's Representative.

**TABLE 4.12
SLURRY SEAL TEST SPECIFICATIONS
TESTS OF EMULSIONS**

TESTS	TEST METHOD	TYPE OF EMULSION	
		ANIONIC	CATIONIC
	ASTM	Quick Setting	Quick Setting
		QS-1H	CQS-1H CQS-1H-LM
Particle Charge Test	D244	Negative	Positive
Viscosity, 60 ml., @ 77 ⁰ F., 5 seconds	D244	15 min. to 100 max.	
Residue by distillation	D244	60 percent by weight, minimum	
Settlement After Five Days (%)	D244	5 percent maximum	
Sieve Test Wt., (%)	D244	0.10 maximum	
Cement Mixing Test	D244, 32-36	2 % Maximum	Not Applicable

**TABLE 4.13
SLURRY SEAL TEST SPECIFICATIONS
TESTS OF RESIDUE**

TESTS	TEST METHOD	TYPE OF EMULSION	
		ANIONIC	CATIONIC
	ASTM	Quick Setting	Quick Setting
		QS-1H	CQS-1H CQS-1H-LM
Penetration 100 gm. @ 77 ⁰ F for 5 seconds	D244	40 to 90 mm	40 to 90 mm
Solubility in Trichloroethylne	D2042 4d	97.5 percent, minimum	
Ductility, 5 cm/mm @	D244	40 cm., minimum	

**TABLE 4.14
SLURRY SEAL TEST SPECIFICATIONS
TESTS ON SLURRY SEAL JOB MIXTURE**

TESTS	TEST METHOD		TYPE OF EMULSION	
	AASHTO	ASTM	ANIONIC	CATIONIC
			Quick Setting	Quick Setting
			QS-1H	CQS-1H CQS-1H-LM
Mixing Time @ 77 ⁰ F (ISSA TB #102)	---	---	120 seconds minimum	120 seconds minimum
Set Time Tests (30 minutes) Blotter Test (ISSA TB #102)	---	---	No Brown Stain	No Brown Stain
Displacement Test	---	---	No Displacement	No Displacement
Water Resistance Test @ 30 Min. (ISSA TB #102)	---	---	No Discoloration	No Discoloration
Wet Stripping Test, Coating (ISSA TB #114)	---	---	90 percent, minimum	
System Compatability	---	---	Compatible	

**TABLE 4.15
SLURRY MIXTURE GRADATION**

Type of Slurry	II	III
General Usage	General seal, medium textured surfaces; second course slurry	First and/or second application of two-course slurry; highly textured surfaces
Sieve Size (USA Standard Series)	P E R C E N T P A S S I N G	
3/8 inch	100	100
No. 4	90-100	70-90
No. 8	65-90	45-70
No. 16	45-70	28-50
No. 30	30-50	19-34
No. 50	18-30	12-25
No. 100	10-21	7-18
No. 200	5-15	5-15

4.7.1.5. WATER. Water for the slurry mixture shall be potable and free from harmful soluble salts.

4.7.2 MATERIAL QUALITY CONTROL.

4.7.2.1. SAMPLING AND TESTING. Prior to the commencement of sealing operations, sources of all materials shall be selected and tested in accordance with the appropriate test requirements. Additional samples of materials shall be furnished as directed by the City's Representative during the progress of the work. The Contractor's proposed job mix design shall be approved by the City's Representative prior to the commencement of construction.

4.7.2.2. JOB MIX DESIGN. No slurry mixture shall be placed until a mix design submitted by the Contractor has been approved by the City's Representative. The exact proportions of asphalt emulsion, aggregate, mineral filler, and water to be used in the preparation of the slurry seal shall be determined by an approved testing laboratory experienced in slurry mix design procedures.

The residual asphalt content of the mix shall be from 7.5 to 13.5 percent of the dry aggregate for type II slurry seal or 6.5 to 12 percent of the dry aggregate for type III slurry seal.

The slurry shall be a homogeneous mixture, sufficiently stable during the entire mixing-spreading period so that the emulsion will not "break". There shall be no segregation of the fines from the coarser aggregate, and the liquid portion of the mix shall not float to the surface. If it is established that a satisfactory mixture meeting the requirements specified herein cannot be produced from the materials furnished, the materials shall be rejected and the Contractor shall submit new samples.

The wet track abrasion test shall not exceed a maximum wear loss of seventy five grams per square foot.

4.7.3 EQUIPMENT. The equipment, tools, and machines required for the performance of the work shall be subject to the approval of the City's Representative and shall be maintained in a satisfactory working condition at all times.

4.7.3.1. SLURRY MIXING MACHINE. The slurry mixing machine shall be a continuous flow mixing unit, capable of delivering accurately predetermined proportions of aggregate, water and asphalt emulsion to a revolving spiraled multi-blade mixer tank, and of discharging the thoroughly-mixed product on a continuous basis. The aggregate shall be pre-wetted immediately prior to mixing with the emulsion. The mixing unit shall be capable of thoroughly blending all ingredients together without violent action. The mixing machine shall be equipped with an approved fines feeder with an accurate metering device or method of introducing a predetermined proportion of mineral filler into the mixer as the

aggregate is fed into the mixer. The fines feeder shall be used when mineral filler is part of the aggregate blend. The mixing machine shall be equipped with a water pressure system and fog-type spray-bar adequate for completely fogging the surface to be sealed with up to 0.05 gallons of water per square yard, immediately ahead of the spreading equipment. The machine shall be capable of mixing materials at pre-set proportions regardless of the speed of the machine and without changing machine settings.

4.7.3.2. SLURRY SPREADER. Attached to the mixing machine shall be a mechanical-type squeegee distributor, having a rubber-like material in contact with the surface to be sealed to prevent unwanted egress of slurry. An appropriate mechanical device for lateral distribution of the slurry shall be operated within the spreader box. There shall also be a steering device and a flexible strike-off. The spreader box shall be adjustable to various widths from eight (8) to twelve (12) feet. The box shall be kept clean with no extensive build-up of asphalt and aggregate on the box. A burlap drag of at least one foot in width shall be attached to the back of the spreader box to smooth out irregularities in the slurry surface.

4.7.3.3. SURFACE CLEANING EQUIPMENT. Power brooms, power blowers, vacuums, air compressors, water flushing equipment, and hand brooms suitable for cleaning the road surface and cracks therein may be used for surface cleaning.

4.7.3.4. AUXILIARY EQUIPMENT. Hand squeegees, burlap mops, shovels and other equipment shall be provided as necessary to perform the work.

4.7.4 ASPHALT EMULSION SLURRY CONSTRUCTION METHODS.

4.7.4.1. RESIDENT NOTIFICATION. The Contractor shall be responsible for notifying all affected residents of pending cleaning and/or sealing operations on streets abutting their properties. Notification shall be no more than forty eight hours, nor less than twenty four hours, in advance of said cleaning/sealing operations. If there should be any change in scheduling for a particular days production, the Contractor shall be required to notify all of the residents affected by the schedule change no later than one hour after the schedule change has been determined.

4.7.4.2. VEHICLE REMOVAL. The Contractor shall be responsible for the removal of all vehicles from the streets to be cleaned, and shall endeavor to notify the owners of the vehicles to move them prior to his cleaning operations. In the event owners of said vehicles cannot be located, the Contractor shall have them towed from the construction zone prior to cleaning and shall be responsible for all costs incurred for said towing.

4.7.4.3. PREPARATION OF SURFACE. In the event that patching or surface smoothing is required to prepare the street surface for the slurry seal, the Contractor shall patch the street surface with hot mix asphalt prior to the application of the slurry sealing. Prior to the application of the slurry seal, the

City's Representative shall give approval that the surfaces have been properly prepared. No slurry seal material will be laid without the City Representative's approval.

4.7.4.4. CLEANING STREETS. Prior to the commencement of Slurry Seal operations, the Contractor shall thoroughly clean and remove all ~~silt~~ **mud** spots and loose or objectionable material from the existing pavement surface. Any standard cleaning method will be acceptable, except that water flushing will not be permitted in areas where poor drainage conditions on the road or at the sides of the road are present, as determined by the City's Representative.

Traffic paint on the surface to be treated that is not tightly bonded to the surface shall be removed.

Areas impregnated with grease, oil, or fuel shall be scrubbed with industrial-type detergent and flushed thoroughly to remove all traces of detergent and oil.

After the cleaning operations have been completed, and prior to the application of the surface treatment, the area to be treated will be inspected by the City's Representative to determine its fitness for receiving the surface treatment. No surface shall be slurry sealed until authorization to do so has been obtained from the City's Representative

SEWER MANHOLE LIDS AND WATER VALVE COVERS. Prior to the application of the seal coat, all sewer manhole lids, survey monument lids, storm drain manhole lids and water valve covers shall be protected from the application of the slurry seal coat by placing building paper over the lids (cut to the exact dimensions of the frames so as to prevent the slurry seal from entering into the seam between the frame and lid). At the completion of the sealing operations, the Contractor shall remove all building paper protectors placed on said lids and covers.

4.7.4.6. TEST SECTION. Prior to full production, the Contractor shall place a test section of at least sixty square yards in an area designated by the City's Representative. The test section shall be placed using the same equipment, methods, and mix as will be used on the job.

If the test section should prove to be unsatisfactory, necessary adjustments to the mix design, equipment, and/or placement methods shall be made. Additional test sections, as required, shall be placed and evaluated for compliance with the specifications. If the test section does not conform to the specification requirements, the defective slurry seal shall be removed. Full production shall not begin without approval of the City's representative.

4.7.4.7. WATER FOG. Immediately prior to application of the slurry seal, the surface of the pavement shall be moistened with a fog spray of water, applied at

the rate of 0.02 to 0.05 gallon per square yard from the spray bar attached to the slurry seal machine. No free water shall pond on the surface of the pavement following the fog spray. The rate of application of the fog spray shall be adjusted during the day to suit pavement temperatures, surface texture, humidity, and dryness of the pavement surface.

4.7.4.8. PREPARATION OF SLURRY. The slurry seal shall be mixed and applied with a slurry machine as outlined below. The amount and type of asphalt emulsion to be blended with aggregate shall be determined by the laboratory mix design. A minimum amount of water, added as specified by the City's Representative, shall be used as necessary, to obtain a workable and homogeneous mixture. The slurry mixture shall be of proper consistency with no segregation when deposited on the surface of the pavement and no additional elements shall be added. The slurry mixture shall show no signs of uncoated aggregate, or premature breaking of emulsion, when applied to the pavement surface. Total time of mixing shall not exceed four minutes.

4.7.4.9. APPLICATION OF SLURRY. Sufficient quantities of the slurry seal mixture shall be fed into the spreader box such that a uniform and complete coverage of the pavement is obtained. The slurry seal machine shall be operated at such a speed that the amount of slurry in the spreader box shall remain essentially constant. The slurry seal shall be placed at a rate within the following general limits: Type II slurry - 10-15 #/yd.²; Type II slurry - 15-20 #/yd.². The finished slurry thickness shall not be less than 3/8 of an inch. No build-up of the cured slurry seal mix shall be allowed to collect in the spreader box. No streaks caused by oversized aggregate particles, or build-up of slurry mix on squeegees, shall be left on the finished surface.

If a uniform thickness cannot be met with one application due to irregularities in the pavement surface, multiple applications shall be made. Where multiple applications are required, as determined by the City's Representative, each application shall be thoroughly cured prior to the application of the subsequent courses.

4.7.4.10. HANDWORK. Approved squeegees and mops shall be used to spread slurry in areas not accessible to the slurry spreader box. Care shall be exercised in leaving no unsightly appearance from handwork. When doing handwork in small areas, especially fill-in behind the slurry machine, the material shall be spread and mopped in the direction of the machine pass.

4.7.4.11. JOINTS. The longitudinal joints between adjacent lanes shall have no visible lap, pinholes, or uncovered areas. Thick spots caused by overlapping shall be smoothed immediately with hand squeegees before the emulsion breaks. Overlaps which occur at transverse joints shall also be smoothed before the emulsion breaks, so that a uniform surface is obtained which contains no breaks or discontinuities.

4.7.4.12. CURING. Treated areas shall be allowed to cure until the treated pavement will not be damaged by traffic. The Contractor shall protect this area for the full curing period with suitable barricades or markers. Areas which are damaged before being opened to traffic shall be repaired by the Contractor.

4.7.4.13. WEATHER LIMITATIONS. The slurry seal shall not be applied when either atmospheric or pavement temperature is below 55 degrees, or above 100 degrees Fahrenheit, when raining or during periods of abnormally high relative humidity, or as determined by the City's Representative.

4.8 CONCRETE WORK. This section defines the materials to be used and the requirements for mixing, placing, finishing and curing all Portland cement concrete work.

4.8.1. MATERIALS. Concrete materials shall conform to the following requirements.

4.8.1.1 PORTLAND CEMENT CONCRETE MATERIAL. Concrete shall be composed of coarse aggregate, fine aggregate, Portland Cement and water, air entrainment and add mixtures and shall conform to the requirements of this section. A concrete mix design shall be prepared by the supplier, certified by an independent testing lab and submitted to the City for review and approval prior to concrete being used in City projects.

A. **PORTLAND CEMENT.** ANSI/ASTM C 150, Type V, shall be used unless otherwise indicated, or approved by the City Engineer. Only one brand of cement shall be used throughout a project, unless otherwise approved by City's Representative. Certified copies of the mill test for the cement shall be furnished upon request of the City's Representative.

B. **AGGREGATE.** Except as otherwise specified herein, concrete aggregate shall conform to all applicable provisions of the latest revision of ASTM Standard Specification C 33.

B.1 Fine Aggregate. Fine aggregate shall consist of natural sand having clean, hard, durable, uncoated grains and shall conform to the requirements of these standards. Other inert materials with similar characteristics shall not be used unless approved by the City Engineer. The amount of deleterious substances shall not exceed the following limits.

**DELETERIOUS MATERIALS
MAXIMUMS**

MATERIAL	PERCENT (by weight)
Clay Lumps	1.00
Coal and lignite	0.50
Material passing No. 200 sieve	3.00
Other deleterious substances such as shale, alkali, mica, coated grains, soft and flaky particles, etc.	3.00
Gypsum	1.00

The combined sum of the percentage of all deleterious substances in fine aggregate listed above shall not exceed three percent by weight.

Fine aggregate shall be well graded and shall range in size from fine to coarse within the following percentages by weight:

FINE AGGREGATE GRADATION REQUIREMENTS

SIEVE SIZE	PERCENT PASSING (by weight)
3/8 inch	100
No. 4	95-100
No. 8	80-90
No. 16	50-75
No. 30	30-50
No. 50	10-20
No. 100	2-5

B.2 Coarse Aggregate. Coarse aggregate shall consist of crushed or natural stone, gravel, slag or other approved inert material with similar characteristics or combination thereof, having clean, hard, durable, uncoated particles free from deleterious matter. Deleterious substances shall not be present in the aggregate in excess of the following limits:

**COARSE AGGREGATE DELETERIOUS MATERIAL
MAXIMUMS**

MATERIAL	PERCENT (by weight)
Soft fragments	2.00
Coal and lignite	0.30
Clay Lumps	0.25
Material passing No. 200 sieve	1.00
Other deleterious substances such as shale, alkali, mica, coated grains, soft and flaky particles, etc.	3.00
Gypsum	1.00

The combined sum of the percentages of deleterious substances (in both coarse and fine aggregate), shall not exceed five percent, by weight.

Coarse aggregate shall be rejected if it fails to meet the following test requirements:

- a. Los Angeles Abrasion Test. If the percent of loss by weight exceeds ten percent at one hundred revolutions, or forty percent at five hundred revolutions.
- b. Sodium Sulfate Test for Soundness. If the weighted average loss after five cycles is more than twelve percent by weight.
- c. Gradation. Coarse aggregate shall be graded by weights as follows:

**COURSE AGGREGATE GRADATION
REQUIREMENTS**

SIEVE SIZE	PERCENT PASSING (by weight)
1 inch	100
3/4 inch	90-100
3/8 inch	20-55
No. 4	0-10
No. 8	0-5

d. Aggregate Size. The maximum size of the aggregate shall be not be larger than one-fifth of the narrowest dimension between forms within which the concrete is to be encased, and in no case larger than three-fourths of the minimum clear spacing between reinforcing bars or between reinforcing bars and forms. For non-reinforced concrete slabs, the maximum size of aggregates shall not be larger than one-fourth the slab thickness.

C. WATER. Sufficient potable water shall be added to the mix to produce concrete with the minimum practical slump, the slump shall not be greater than four inches. However, a higher slump may be allowed with plasticizers, providing there is no loss of strength or durability and prior approval for use is obtained from the City's Representative.

The maximum permissible water-cement ratio (including free moisture in the aggregate) shall be five gallons per bag of cement (0.44) for Class A and five and three-quarter gallons per bag of cement (0.51) for Class C concrete.

D. ENTRAINING AGENT. An air-entraining agent shall be used in all concrete exposed to the weather. The agent shall conform to ASTM designation C 260. Air content for air-entrained concrete shall be five percent by volume (plus or minus one percent). The air-entraining agent shall be added as a liquid to the mixing water by means of mechanical equipment capable of accurate measurement and control.

E. ADMIXTURES

E.1. **Pozzolan.** When authorized by the City Engineer, pozzolan conforming to the requirements of ASTM C 618 Class F may be added to the concrete mix as outlined below:

- a. Pozzolan may be used as a replacement to the required Portland Cement content provided no other supplemental specification prevents its use. The maximum percentage of Portland Cement replacement on a weight basis is **15 percent**.
- b. Pozzolan/cement replacement ratio is 1.25 to 1 (pozzolan/cement).
- c. Water/cement ratio is established before Portland Cement is replaced with pozzolan.
- d. Loss of ignition of pozzolan is less than 1 percent.
- e. Trial batches for each aggregate source and concrete class have been run for each mix design.
- f. All other requirements and references to testing procedures and specifications of Section 4.8 "Concrete Work" shall apply.

Pozzolan shall be sampled and tested as prescribed in ASTM C 618 and ASTM C 311. The Concrete Supplier shall obtain and deliver to the City's Representative a certification of compliance signed by the pozzolan supplier identifying the pozzolan and stating that the pozzolan delivered to the batching site complies with applicable specifications.

Pozzolan material shall be handled and stored in the same manner as Portland Cement. When facilities for handling bulk pozzolan are not available, the pozzolan shall be delivered in original unopened sacks bearing the name and brand of supplier, the type and source of the pozzolan, and the weight contained in each sack plainly marked thereon.

Different brands or types of pozzolan shall not be mixed together unless written permission has first been obtained from the Owner's Representative. All pozzolan used in the manufacture of concrete for any individual structure shall be of the same type, and from the same source unless otherwise approved by the City's Representative.

COMPLIANCE ANALYSIS. During the course of concrete testing, the City may require, at random, additional concrete cylinders for the purpose of performing a "Petrographic Examination" in accordance with ASTM C 856.

The “Petrographic Examination” may be initiated when compressive strength tests show inconsistencies, when batch tickets show indications that material is batched which is not in accordance with approved mix designs, or when there are other indicators that the concrete may not meet Standards.

The “Petrographic Examination” will be performed by a Certified Testing Laboratory qualified to perform such testing. In the event that the sampled concrete is not in compliance with these standards, the supplier of the concrete will be required to pay for the “Petrographic Examination” and will no longer be allowed to supply concrete for use in any improvements for which City Standards apply until acceptable adjustments are made. If the sampled concrete is found to be in compliance with these standards, the City will pay the cost for the “Petrographic Examination”. Additional testing may be required by the City Engineer, at the suppliers expense, to determine the extent of the non-compliant concrete. All work on a project, affected by the non-compliant concrete, will be suspended until the non-compliant concrete work is brought into compliance.

The “Petrographic Examination” will determine the quantity of cementitious matrix including mineral admixture (pozzolan/fly ash) in the mix, proportions of the mix, and other properties of the sampled concrete to verify compliance with the approved mix design. The acceptability of the concrete represented by the examination shall be established by comparing the proportions determined by the examination with those indicated on the batch tickets. When this comparison shows that the pozzolan proportions are within 2% +/- of the approved mix design the admixture proportions will be considered to be in compliance. When comparisons of other proportions of the mix indicate that the concrete is not within acceptable allowable deviation limits the concrete may be rejected even though the pozzolan proportion is acceptable.

The City may use the results of the “Petrographic Examination”, inspection records, observation of batch plant operation, compressive strength test results, or any other pertinent information to determine compliance. If any portion of a project is found to be in non-compliance, additional testing shall be required to verify full compliance of all concrete within the project. If the City Engineer has reasonable cause, he may require removal and replacement of any concrete which has been found to be in non-compliance. (For the purpose of demonstrating the acceptability of this admixture specification, compressive strength alone shall not be considered as justification for acceptance).

Repeated violations of these admixture standards may subject the offending concrete supplier to be prohibited from providing concrete

that is used in public or private infrastructure improvements within the City of Toquerville.

E.2. **Calcium Chloride.** Calcium Chloride shall not be added to any concrete mix. Non-chloride accelerators may be used upon approval of the City Engineer or his Representative.

F. CONCRETE MIX. For the purpose of practical identification, concrete has been divided into classes. The basic requirements of class A and class C concrete and the use for each is defined in Table 4.16 of the City Standard Specifications.

r, r.1 02/03

F.1. **Submittals.** The following information must be included with all concrete mix designs submitted for review and approval by the City as per subsection 4.8.1.1 “Portland Cement Concrete Material”.

- a. Test results on coarse and fine aggregates to verify compliance with applicable specifications.
- b. Trial batch test results and past history test information on proposed mix designs, which support compliance with the requirements for compressive strength, durability, etc. Performance curves used to verify 28 day, 56 day, and 90-day strengths must be submitted with trial batch tests or history information.
- c. Certification of compliance from the cement supplier, the pozzolan supplier, and the air-entraining agent supplier, stating that the materials being delivered are in compliance with applicable specifications.
- d. All mix designs shall be certified by a Certified Testing Laboratory.

G. BATCH PLANT TICKET. All concrete produced and delivered to a job site within City of Toquerville, will be accompanied by a batch plant ticket. The ticket will state the time manufactured or batched and accurately show all components used for that particular load or batch. Sufficient copies shall be provided for testing personnel and City of Toquerville representatives, if requested.

**TABLE 4.16
CONCRETE MIX SPECIFICATIONS**

Class	Minimum Cement Content		Maximum Water Content** (gal./bag of cement)	Maximum Slump	Minimum 28-day Comp. Strength (psi)	Primary Use
	(Bags/ C.Y.)	(pounds/ C.Y.)				
	6	564	5	4" 1 ½"*	4000	Reinforced structural concrete; sidewalks; curbs & gutters; cross gutters; pavements; unreinforced footings
C	5	470	5.75	4"	3000	Minor non-structural items such as thrust blocks; anchors, mass concrete, etc.

* For machine placement only.

** Including free moisture in aggregate.

NOTE: Unless otherwise specifically designated by the City Engineer all concrete placed shall be Class "A", six-bag mix, with a minimum allowable compressive strength of 4000 p.s.i at the age of twenty eight days. r, r.1 02/03

4.8.1.2 CONCRETE REINFORCING MATERIALS. Concrete reinforcing materials shall conform to the following requirements.

A. STEEL BARS. All bar material used for reinforcement of concrete shall be hard grade deformed round steel conforming to the requirements of ASTM Designation A 615. All reinforcing steel shall be minimum grade sixty (60) unless approved otherwise by the City Engineer. All bars shall be deformed, round and have a net section equivalent to that of plain bar of equal nominal size. Only hard grades will be used. Twisted bars will not be accepted.

All rebar shall be clearly marked with identifying markings in accordance with industry standards.

All reinforcing steel, at the time concrete is placed, shall be free from flaws, cracks, rust, oil, dirt, paint, or other coatings that will destroy or reduce the bond.

B. WIRE OR WIRE FABRIC REINFORCEMENT. Welded wire fabric for concrete reinforcement shall conform to the requirements of ASTM A 185. Wire for concrete reinforcement shall conform to the requirements of the "Standard Specification for Cold Drawn Steel Wire for Concrete Reinforcement" ASTM A-82. All wire reinforcement, wire fabric, or expanded metal shall be of the type designated unless an alternate type is approved by the City Engineer.

C. STEEL FIBER REINFORCEMENT. Deformed steel fiber for concrete reinforcement shall conform to the requirements of ASTM A-820, type I, deformed fiber, except that the average tensile strength shall be not less than 150,000 psi.

D. SYNTHETIC REINFORCING FIBERS. Engineered synthetic reinforcing fibers shall be 100% polypropylene collated, fibrillated fibers. Fiber length, and amount per manufacturer's recommendations shall correspond with the concrete mixture (generally 1.5 pounds per cubic yard of concrete).

Physical property of the fibers shall be as follows:

Specific Gravity	0.91
Modulus of elasticity	500,000 to 700,000 psi
Tensile strength	70,000 to 110,000 psi
Length	0.25 to 2.50 inches

The fiber manufacturer shall certify that all polypropylene fibers meet the physical properties, and are specifically manufactured for use in concrete from virgin polypropylene, containing no reprocessed olefin materials. If the fiber manufacturer is other than the brand name listed on the literature and packaging, the certification must be from the original manufacturer of the fibers.

Fiber-mesh shall be added only at the concrete batch plant to assure uniform and complete dispersion of the collated-fibrillated fiber bundles into single mono-filaments within the concrete.

4.8.1.3 CURB, GUTTER, SIDEWALK AND BASE MATERIALS. Concrete and base materials shall conform to the following requirements.

A. GENERAL. This subsection defines materials, practices and designs to be used in the construction of all public curb, gutter and sidewalk.

All curb, gutter and sidewalk shall consist of air-entrained Type V Portland Cement Concrete and shall be constructed on a prepared subgrade in accordance with these specifications. All work shall conform to the lines and grades, thickness, and typical cross sections shown on the approved plans or established by the City's Representative.

B. SUBGRADE. The subgrade shall be excavated and filled with suitable material, as specified in Section 4.3.2.3 of these standards. All soft, yielding and otherwise unsuitable material shall be removed and replaced with suitable materials as outlined above. Filled sections shall be compacted and extend to a minimum of one (1) foot outside the form lines according to Section 4.3.2.3 of these standards.

C. GRAVEL BASE COURSE. A gravel base course consisting of crushed road base gravel shall be placed under all curbs, gutters, driveways, waterways, sidewalks and other miscellaneous flatwork. The gravel base material shall conform to the requirements contained in Section 4.5.7 of these specifications. Where the foundation material is found to be unstable, the Contractor shall furnish and place sufficient additional gravel or other suitable material as directed by the City's Representative to provide an adequate foundation upon which the concrete will be placed.

4.8.2. CONSTRUCTION METHODS AND EQUIPMENT. The methods employed in performing the work, all equipment, tools and machinery, and other appliances used in handling the materials and executing the work shall be the responsibility of the Contractor. The Contractor shall make such changes in the methods employed and in the equipment used as are necessary whenever the concrete being installed does not meet the specifications herein established. These methods shall include, but are not limited to the following:

4.8.2.1 GENERAL CONCRETE PLACEMENT. Generally, concrete shall be placed as follows.

A. FORMS. Forms shall be properly built and adequately braced to withstand the liquid weight of concrete being placed in the forms. All linings, studding, whaling and bracing shall be such as to prevent bulging, spreading, loss of true alignment or displacement while placing and during setting of concrete.

B. PREPARATIONS. Prior to batching and placing concrete, all equipment for mixing and transporting the concrete shall be cleaned. All debris and ice shall be removed from the areas to be occupied by the concrete. All forms shall be oiled with a form-release agent. Masonry support or filler units that will be in contact with concrete shall be well drenched with water (except in freezing weather). Reinforcement shall be thoroughly cleaned of ice or other coatings. Water shall be removed from areas to receive concrete.

Reinforcement that has become too hot, due to sun exposure, in the opinion of the City Representative, will be cooled with water prior to concrete being placed.

When placing concrete on earth surfaces, the surfaces shall be free from frost, ice, mud, water and other deleterious materials. When the subgrade is dry or pervious, it shall be sprayed with water prior to the placing of concrete or shall be covered with water-proof sheathing paper or a plastic membrane. No concrete shall be placed until the preparatory work (i.e. forms, reinforcement, etc) has been inspected and approved by the City's Representative.

C. CONCRETE MIXING. The concrete shall be mixed until there is a uniform distribution of the materials. Sufficient water shall be used in concrete in which reinforcement is to be imbedded, to produce a mixture which will flow sluggishly when worked and can be conveyed from the mixer to the forms without separation of the coarse aggregate from the mortar. In no case shall the quantity of water used be sufficient to cause the collection of a surplus in the forms.

Ready-mixed concrete shall be mixed and delivered in accordance with the requirements set forth in Specifications for Ready-Mixed Concrete (ASTM C-94). Concrete shall be delivered and deposited in its final position within sixty (60) minutes after the cement and water have been added to the mixture.

D. DEPOSITING. Concrete shall be deposited as nearly as practical in its final position to avoid segregation due to rehandling or flowing. Concrete

placement shall be carried on at such a rate that the concrete is at all times plastic and flows readily into the corners of forms and around reinforcing bars. Concrete that has partially hardened or is contaminated by foreign material shall not be deposited in the work. Re-tempered concrete shall not be used.

Temperature of the mixed concrete shall be maintained between 60°F and 90°F at time of placement.

All concrete in structures shall be compacted by means of high-frequency internal vibrators of approved type and design during the operation of placing, and shall be thoroughly worked around reinforcement and embedded fixtures and into the corners of the forms. Care must be taken not to over use vibrators causing separation of cement and aggregates.

E. FINISHING. After the concrete for slabs has been brought to the established grade and screeded, it shall be worked with a magnesium float and then given a light "broom" finish. In no case shall dry cement or a mixture of dry cement and sand be sprinkled on the surface to absorb moisture or hasten hardening. Surface edges of all slabs shall be rounded to a radius of one quarter to one half (1/2) inch with standard concrete finishing tools. Additional water shall not be sprinkled on the surface to aid finishing.

F. CURING AND PROTECTION. As soon as the concrete has hardened sufficiently, it shall be protected and cured in accordance with ACI Standards. The finished surface shall be kept moist for a minimum of seven days, or a chemical curing agent used to prevent the concrete from premature drying.

The freshly finished surface shall be protected from hot sun and drying winds until it can be sprinkled or covered as above specified. The concrete surface shall not be damaged or pitted by rain. The Contractor shall provide and use, when necessary, sufficient tarpaulins to completely cover all sections that have been placed within the preceding twelve (12) hours. The Contractor shall erect and maintain suitable barriers to protect the finished surface. Any section damaged from traffic, weather, people or other causes occurring prior to its final acceptance, shall be repaired or replaced by the Contractor in a manner satisfactory to the City's Representative.

G. WEATHER LIMITATIONS. Concrete shall not be poured where the air temperature is lower than thirty five (35⁰)degrees F. unless approved by the City's Representative. When there is likelihood of freezing during the curing period, the concrete shall be protected by means of an insulating covering to prevent freezing of the concrete for a period of not

less than seven days after placing. Equipment for protecting the concrete from freezing shall be available at the job site prior to placing concrete. Particular care shall be exercised to protect edges and exposed corners from freezing. Cold weather placement shall generally follow the requirements of ACI 306.1

Hot weather placement shall generally conform to the requirements of ACI 305.

4.8.2.2 CONCRETE REINFORCEMENT INSTALLATION. Concrete reinforcement shall be installed in accordance with ACI (American Concrete Institute) standard requirements for reinforced concrete and generally as follows.

A. BENDING. Reinforcing bars shall be accurately formed to the dimensions indicated on the plans. Bends for stirrups and ties shall be made around a pin having a diameter not less than two (2) times the minimum thickness of the bar. Bends for other bars shall be made around a pin having a diameter not less than six (6) times the minimum thickness of the bar, except that for bars larger than one (1) inch, the pin shall be not less than eight (8) times the minimum thickness of the bar.

B. SPLICING. Splicing of bars at points other than where shown on the plans will be permitted only by approval of the City's Representative. Splices of reinforcement at points of maximum stress shall be avoided wherever possible, and when used shall be staggered and in accordance with ACI Standards. The minimum overlap for a lapped splice shall be twenty four (24) bar diameters, but not less than twelve (12) inches and properly tied together.

C. PLACING. All reinforcing bars shall be placed accurately in the position shown on the plans, and shall be securely held in position by annealed iron wire ties of not less than sixteen (16) gauge or suitable clips at intersections. All reinforcing bars shall be supported by metal supports, spacers or hangers, in such a manner that there will not be any displacement while placing concrete.

D. EMBEDMENT AND PROTECTION. All reinforcing steel shall be protected by concrete embedment and protective cover as shown in Table 4.17, such cover in each case being the shortest distance between the face of the form or concrete surface, and the nearest edge or face of the reinforcement.

**TABLE 4.17
REINFORCING BAR CLEARANCE**

LOCATION OF REINFORCEMENT	COVER
Bottom bars - where concrete is deposited against ground without use of forms.	Not less than 3"
Main bars - where concrete is exposed to the weather, or exposed to the ground but placed in forms.	Not less than 2"
Bars in slabs and walls not exposed to the ground or weather.	Not less than 1"

4.8.2.3 CURB, GUTTER AND SIDEWALK CONCRETE PLACEMENT.

The concrete shall be placed either by an approved slipform/extrusion machine, by the formed method, or by a combination of both methods. Curb and gutter shall be placed as follows:

A. MACHINE PLACEMENT. The slipform/extrusion machine shall place, spread, consolidate, screed, and finish the concrete in one complete pass to provide a dense and homogeneous concrete section. A minimum amount of hand finishing should be necessary. The machine shall shape, vibrate, and/or extrude the concrete for the full width and depth of the concrete section being placed. It shall be operated with as nearly a continuous forward movement as possible. All operations of mixing, delivery, and spreading concrete shall provide for uniform progress, with stopping and starting of the machine held to a minimum.

B. FORMED METHOD. The forms shall be of wood, metal, or other suitable material straight and free from warp, having sufficient strength to resist the pressure of the concrete without displacement and sufficient tightness to prevent the leakage of mortar. Flexible or rigid forms of proper curvature shall be used for curves having a radius of one hundred feet, or less.

Forms shall be cleaned and coated with an approved form-release agent before concrete is placed against them.

The concrete shall be deposited into the forms without segregation and then tamped and spaded or mechanically vibrated for thorough consolidation. Front and back forms shall be removed without damage to the concrete after it has set.

C. FINISHING. The concrete shall be finished smooth, by a wood or magnesium float and then given a final surface texture using a light broom

or burlap drag unless otherwise specified or directed. Concrete that is adjacent to forms and formed joints shall be edged with a standard jointer or edging tool as shown in the standard drawings. The top, face, and flow-line of the curb, and the top of driveway apron, shall be finished true to line and grade without any noticeable surface irregularities.

The Contractor shall be responsible for neatly stamping an "S" in the curb face at all sewer lateral locations and a "W" in the curb face at all water lateral locations along the curb.

The gutter shall not pond water. The surface of the curb and gutter shall not exceed more than one fourth (1/4) of an inch in ten (10) feet. No part of the exposed surface shall present a wavy appearance.

D. JOINTING.

D.1 Contraction Joints. Transverse weakened-plane contraction joints shall be constructed at right angles to the curb line at intervals not exceeding the values in accordance with standard drawings. Where the sidewalk abuts the curb and gutter, joints should align unless otherwise approved by the City's Representative. Joint depth shall at least be one quarter (1/4) of the cross section depth of the concrete. Generally, surface areas shall not exceed fifty square feet without contraction joints unless otherwise approved by the City's Representative.

Contraction joints may be sawed, hand-formed, or made by placing division plates in the form-work. Sawing shall be done within twenty-four hours after the concrete has set to prevent the formation of uncontrolled cracking. The joints may be hand-formed either by using an appropriate jointing tool, or a thin metal blade to impress a plane of weakness into the plastic concrete, or by inserting one eighth (1/8) inch thick steel strips into the plastic concrete temporarily. Steel strips shall be withdrawn before final finishing of the concrete. Where division plates are used to make contraction joints, the plates shall be removed after the concrete has set while the forms are still in place.

D.2 Expansion Joints. Expansion joints for curb and gutter shall be constructed at right angles to the curb line at no greater than one hundred fifty (150) foot intervals, at immovable structures and at points of curvature for short-radius curves. Spacing for sidewalk expansion joint shall not exceed twenty (20) feet. Filler material for expansion joints shall conform to requirements of ASTM D-994, D-

1751, or D-1752 and shall be furnished in a single one half inch thick piece for the full depth and width of the joint.

Expansion joints in a slipformed curb and gutter shall be constructed with an appropriate hand tool by raking or sawing through partially set concrete for the full depth and width of the section. The cut shall be only wide enough to permit a snug fit for the joint filler. After the filler is placed, open areas adjacent to the filler shall be filled with concrete and then troweled and edged. Contaminated concrete shall be discarded.

Alternately, an expansion joint may be installed by removing a short section of freshly extruded curb and gutter, immediately installing temporary holding forms, placing the expansion joint filler, and replacing and reconsolidating the concrete that was removed. Contaminated concrete shall be discarded.

D.3 Other Jointing. Construction joints may be either butt or expansion-type joints. Curbs and gutters constructed adjacent to existing concrete shall have the same type of joints as in the existing concrete with similar spacing, however, contraction joint spacing shall not exceed ten feet.

A silicone joint sealer as defined in ASTM C 962 shall be applied to all form-plate expansion joints. The silicone joint sealer shall be applied under pressure to a depth of not less than two inches from the outside surface of the curb and gutter.

E. PROTECTION. At all times during the construction of the project, the Contractor shall have materials available at the site to protect the surface of the plastic concrete against rain or other detrimental elements. These materials shall consist of waterproof paper, plastic sheeting or other approved material. For slip-form construction, materials to protect the edges shall also be required.

When concrete is being placed in cold weather and the temperature is expected to drop below 35 degrees F., suitable protection shall be provided to keep the concrete from freezing until it is at least seven (7) days old. Concrete damaged by frost action shall be removed and replaced.

F. CURING. Concrete shall be cured for at least three days after placement to protect against loss of moisture, rapid temperature change, and mechanical damage. Liquid membrane curing compound, or other approved methods, or a combination thereof may

be used as the curing material. Membrane curing shall not be permitted in frost-affected areas when the concrete will be exposed to de-icing chemicals within thirty days after completion of the curing period.

G. BACKFILLING. At least three days after placement and after form removal, the concrete shall be backfilled to the lines and elevations as shown on the drawings or as required by the City's Representative. The length of time may be shortened if it can be demonstrated that the concrete has reached design strength. Any concrete damaged during backfill or other operations, shall be removed and replaced as directed by the City's Representative.

H. CONCRETE REPAIR. In lieu of removing and replacing concrete containing minor cracks, the City's Representative may direct the Contractor to repair the affected sections by sawing, routing, cleaning and sealing the cracks. All cracks repaired shall be sealed with a polyurethane TTS-230 type II crack filler or an approved silicone base joint sealer. Where modifications are to be made to existing concrete, the edges to be poured against shall be sawcut in neat, straight lines and the new concrete shall be edged with a standard edging tool.

I. WEATHER LIMITATIONS. Concrete shall not be poured when there is likelihood of freezing. During the curing period, the concrete shall be protected by means of insulating covers to prevent freezing of the concrete for a period of not less than seven days after placing. Equipment for protecting the concrete from freezing shall be available at the job site prior to placing concrete. Particular care shall be exercised to protect edges and exposed corners from freezing.

Hot weather concreting shall be in accordance with the latest ACI 305 Standards for "Hot Weather Concreting".

4.8.2.4 CONCRETE BASE MATERIALS PLACEMENT. The placement of concrete base materials under curb, gutter and sidewalk shall conform to Section 4.5.7 of these standards.

4.8.3. QUALITY CONTROL. All concrete and base materials shall be placed in accordance with these standards and tested as follows. These are minimum requirements and additional testing may be required by the City's Representative or the Project Geotechnical Engineer.

Testing documentation provided to the City's Representative shall fully address the requirements of these standards.

4.8.3.1 CONCRETE TESTING. Minimum testing of the concrete shall be as follows:

Mix Design
Certification: One per job. Testing shall be according to the latest ASTM standards.

Compressive
Strength Tests: One set of four cylinders for each fifty cubic yards of concrete placed or portion thereof. Tests shall be according to ASTM C-31.

Air Entrainment: Tested at beginning of placement until two consecutive loads pass. Others tests shall be taken as required. Tests shall be according to ASTM C-231.

Slump Tests: Tested at beginning of placement until two consecutive loads pass. Others tests shall be taken as required. Tests shall be according to ASTM C-143.

4.8.3.2 CONCRETE BASE MATERIAL TESTING. Minimum testing of the curb, gutter and sidewalk base materials shall be as follows:

Gradation Tests: One test per five hundred (500) lineal feet of curb & gutter or fraction thereof. One test per one thousand three hundred fifty (1,350) square feet of a combination of sidewalk and driveway, or fraction thereof.

The sieve analysis shall be according to ASTM C-136, C-117.

Proctor: One determination for each source of base course as necessary to provide required compaction testing. Test shall be according to ASTM D-1557, Method A or D (modified proctor).

Moisture
Density Tests: One test per three hundred (300) lineal feet of curb & gutter and one test per three hundred (300) lineal feet of a combination of sidewalk and driveway or fraction thereof. Moisture content shall be at plus or minus two percent of optimum. Proper moisture shall be maintained until the concrete is poured. Tests shall be according to ASTM D-1556 or D-2922 and D-3017.

Thickness: One random boring or test hole per two hundred (200) lineal feet of curb & gutter and one random boring or test

hole per two hundred (200) lineal feet of a combination of sidewalk and driveway or fraction thereof. If sufficient observation has been made by the City's Representative to verify required thickness, the City's Representative may waive thickness testing. Said waiver must be in writing.

No single measured thickness shall be less than the required thickness.

4.8.3.3 ACCEPTANCE. A total of four (4) concrete test cylinders shall be taken at time of pouring from loads passing the requirements of section 4.8.3.1. One cylinder, shall be broken at seven (7) days and shall be used as an indication of future strength. Two (2) cylinders shall be broken at twenty eight (28) days. If the average of the twenty-eight day breaks is below minimum compressive strength, the concrete may be rejected unless retests prove otherwise. At the Contractor's option, the fourth cylinder (the "hold" cylinder) may be broken at twenty eight (28) days, and included with the average, or it can be held for future testing if additional tests are needed.

Concrete with an average compressive strength below the required strength shall be reviewed by the City's Representative. The "hold" cylinder, if available, may be broken or other specialized tests (such as a spectrum analysis) may be required. If additional tests are required to determine if strength tests are representative they shall be performed by coring in accordance with ASTM C-42 method or other acceptable non-destructive methods. The re-tested strength shall be the average of three cores (or other acceptable method). The City's Representative may accept the concrete as a result of these additional tests, or may require the work to be removed and replaced. The City's Representative shall make the final decision. All costs incurred in resampling and retesting are not the responsibility of the City.

All curb, gutter or sidewalk base material not in compliance with these standards shall be removed and replaced. Any costs for testing the re-work are not the responsibility of the City.

4.9 RESTORATION OF EXISTING SURFACE IMPROVEMENTS.

4.9.1 INTRODUCTION. The Contractor shall be responsible for the protection and restoration, or replacement, of all existing improvements on public or private property and all improvements placed during the progress of the work. Existing improvements shall include, but not be limited to, asphalt, curbs, gutters, ditches, driveways, culverts, fences, signs, sidewalks, utilities, landscaping and walls, etc. All existing improvements damaged during construction shall be reconstructed to equal or better condition than that which existed. However, as a minimum, the requirements contained in these specifications shall be adhered to.

All traveled surfaces shall be maintained flush with the existing surfaces at all times until permanent repairs are completed.

Prior to the beginning of any work activity involving tunneling under, or making any excavation in any street, alley or other public place, the Contractor shall comply with all requirements for permits and bonding. The Contractor shall also comply, during the work activity, with all of the requirements contained within Section 2.5, BARRICADES AND WARNING SIGNS - WORK AREA PROTECTION, of these specifications.

4.9.2 GRAVEL SURFACES. Where existing gravel surfaces are damaged due to trenching or other works the surfaced areas (such as roads and driveways) shall be restored and maintained as follows.

4.9.2.1 The gravel shall be placed deep enough to provide a minimum of six inches thickness, or to match the thickness of existing material, or to these specifications, whichever is greater.

4.9.2.2 The gravel shall be placed and compacted in the trench (or other work) at the time it is backfilled. The surface shall be maintained by blading, sprinkling, rolling or adding gravel in order to maintain a safe uniform surface satisfactory to the City's Representative. Excess material shall be removed from the premises immediately.

4.9.2.3 Material for use on gravel surfaces shall conform to the requirements contained within these specifications.

4.9.3 BITUMINOUS SURFACES. Where existing bituminous surface is damaged due to trenches or other works, the bituminous surfaced roads, driveways, parking areas, etc., shall be restored within five (5) days as follows:

4.9.3.1 Mud or other soft or spongy material shall be removed from the trench and the space filled with granular backfill to within twelve (12) inches of finished grade. The granular backfill shall be rolled and compacted to a minimum of ninety-five (95) percent of maximum dry density in layers not exceeding six (6) inches in compacted thickness. Base gravel shall then be placed to a depth equal to the original gravel base or the requirements of these specifications, but not less than six (6) inches thick and compacted to a minimum of ninety five (95) percent of maximum dry density.

4.9.3.2 Prior to permanent resurfacing, the Contractor shall saw-cut the existing paving to provide vertical, clean, straight lines as nearly parallel to the centerline of the trench as practical. The existing bituminous paving shall be cut back beyond the limits of any excavation so that the edges of the new paving will rest on at least six (6) inches of undisturbed base material.

4.9.3.3 Pavement restoration shall include tacking of pavement edges with type SS-1H bituminous material, and placing and compacting plant mix asphalt in

accordance with these specifications to the level of the adjacent pavement surfaces.

4.9.3.4 The bituminous surface shall be restored by standard paving practices to a thickness equal to the original pavement or the requirements of these specifications, but in no case less than two inches. The finished repaired surface shall not deviate more than one quarter (1/4) inch (vertically) from the existing road surface. Any deviations greater than that specified shall be immediately removed and replaced to the proper standards.

4.9.4 CONCRETE SURFACES. All concrete curbs, gutter, sidewalks, and driveways shall be removed and replaced to the next joint or score line beyond the actually damaged or broken sections; or saw-cut to neat, plane faces. All new concrete shall match, as nearly as possible, the appearance and texture of adjacent concrete improvements unless adjacent improvements do not meet these specifications.

All damaged base material shall be restored and compacted in accordance with these specifications.

SECTION 5 SIGNING AND PAVEMENT MARKINGS

5.1 INTRODUCTION. This section covers street signing and pavement markings.

5.2 SIGNING MATERIALS, FABRICATION AND PLACEMENT. All traffic, street name and other roadside signage shall follow the requirements for materials, fabrication and installation outlined in the standard drawings and these specifications.

5.2.1 STREET NAME SIGNS. The sign face materials shall consist of reflective “high intensity” grade sheeting (“engineer” or similar grade materials shall not be used). The sign face colors shall be green for public streets and blue for private streets. The street sign blanks shall consist of high tensile, degreased aluminum in accordance with the standard drawings. The street name sign face layout detail, as shown on standard drawings, shall be followed. The "Street Name Sign Designation Form" found in the standard drawings shall be completed and approved by the City Address Coordinator prior to the fabrication and installation of any new street name signs.

The street name signs shall be installed on galvanized steel posts that conform to the requirements contained in the standard drawings. The installation method and location shall be in accordance with the standard drawings and the MUTCD.

5.2.2. TRAFFIC SIGNS. All traffic signs shall conform to the requirements relating to color, face, size, markings, lettering and location of installation found in the Manual of Uniform Traffic Control Devices for Streets and Highways (MUTCD). Traffic sign face material shall consist of reflective “high intensity” grade sheeting (FP-85 Type IIIA).

Traffic sign blanks shall consist of 0.1 inch thick high tensile degreased aluminum alloy in, accordance with 6061-T6, with alodine 1200 finish.

All traffic signs shall be installed on galvanized steel posts in accordance with the standard drawings.

5.2.3 VISIBILITY. All street name and traffic signs shall be installed in such a manner as to provide adequate advance visibility for an approaching driver in accordance with MUTCD and other approved standards.

5.3 PAVEMENT MARKINGS. Pavement markings shall include all traffic lane striping, pavement words and symbols, and other traffic oriented street markings.

The standards regarding color, type, size and layout of pavement markings *Manual on Uniform Traffic Control Devices for Streets and Highways*. However, in such cases where the Utah Department of Transportation standards take precedence, they should be followed.

5.3.1 LINE TYPES

- A. **SOLID LINES.** Solid lines shall consist of a four (4) inch wide solid white or yellow lines.
- B. **SKIP (BROKEN) LINES.** Skip lines shall consist of line segments and gaps on a 3 to 1 ratio. The line segment shall be four (4) inches wide (white or yellow line) and generally ten (10) feet long. The gap segment shall generally be thirty (30) feet long.
- C. **DOUBLE LINES.** A double line shall consist of two four (4) inch wide solid yellow lines separated by a minimum four (4) inch wide space.
- D. **LANE LINES.** Lane lines shall consist of a four (4) inch wide skip line, white in color. Lane lines separate lanes of traffic traveling in the same direction. A four (4) inch wide or wider solid white line may be used as the lane line in critical areas where it is advisable to discourage lane changing, such as on bridges having width restrictions and in intersection areas where lane changing disrupts traffic flow.
- E. **STOP BARS.** Stop bars shall be white. Width shall be two (2) feet, unless otherwise directed.

5.3.2 PAVEMENT WORD AND SYMBOL MARKINGS. Shall be in accordance with the MUTCD.

5.3.3 TRAFFIC PAINT. Traffic paint shall conform to the latest requirements contained in the State of Utah Department of Transportation "Standard Specifications for Road and Bridge Construction". Traffic paint shall be applied only when all of the following conditions are met:

- A. The air temperature is above forty (40) degrees Fahrenheit.
- B. The temperature of the surface to be painted is between forty (40) and one hundred (100) degrees Fahrenheit.
- C. The surface to be painted is clean and dry, and
- D. The weather is not windy, foggy or humid.

Painting shall be done in a neat and workmanlike manner. Paint shall be applied smoothly and uniformly in accordance with the manufacturers specifications. The finish shall be uniform in appearance and coverage.

5.3.4 TEMPORARY MARKINGS. Temporary markings may be required until permanent markings can be properly placed. Temporary pavement markings shall be reflectorized traffic paint or other material approved by the City's Representative.

5.3.5 RAISED PAVEMENT MARKERS. Raised pavement markers shall conform, in terms of materials and application, to the latest standards found in the requirements of the State of Utah Department of Transportation or other approved standards and shall be approved for use prior to application.

SECTION 6

STREET LIGHTING

6.1 INTRODUCTION. All street lights erected within the city, whether in a public street, easement, subdivision, or in any building project requiring street improvements, shall conform to the standards covered in this section of these specifications. All work and materials shall be in conformance with the latest edition of the “Utah Power and Light Underground Power Construction Standards and Specifications”.

6.2 STREETLIGHT POLE. See Utah Power & Light.

6.3 POLICY NUMBER 5.6 “Street Lights and Yard Lights”. See Utah Power & Light.

STREET LIGHT INSTALLATION AGREEMENT

NOTE: Contact City Water and Power Department for current agreement

AGREEMENT made as of the ___ day of _____, 20___, between the City of Toquerville, herein referred to as the "City", and _____, Toquerville, Utah, herein referred to as the "Property Owner", wherein it is agreed that the best interests of the City and the Property Owner will be served by the installation of one or more street lights in the Property Owner's neighborhood.

In consideration of the installation by the City of that street lighting described on Exhibit "A", attached hereto and made a part hereof, the undersigned property owner does agree to pay the sum of \$_____ as his prorata portion of the cost thereof, such amount payable in three equal annual installments of \$_____ each, without interest, until paid in full.

The Property Owner agrees that in the event of a default in the payment of any installment when due, the City shall be entitled to charge and the Property Owner shall pay interest on the entire balance owing at the rate of 18% per annum, and the City shall have the right to accelerate the entire remaining balance and declare the same immediately due and payable in the event of such default. In the event suit is commenced to collect any delinquent amount hereunder, the Property Owner does agree to pay reasonable attorney's fees in connection therewith. The first installment shall be due on the first day of the month following completion of the installation, and on the first day of that same month each year thereafter. The payment of installments shall be made at the City Office Building on or before the date they are due, and annual notice from the City of the due date of such installments is hereby waived.

The Property Owner agrees to provide rights-of-way, if any are needed over or across property owned by the undersigned for the purpose of such installation. He does further agree that in the event of a sale of the property within the area described on Exhibit "A" and affected hereby, the successors in interest thereon shall be obligated to make the payments provided hereunder, and this agreement recorded as notice to subsequent purchasers of such obligation.

The engineering required for installation of the street lights shall be provided by the City without cost, and such engineering is therefore not included in the amount for which the Property Owner agrees to pay. Electricity to illuminate the street lights and long term maintenance and repair of the lighting system shall be the responsibility of the City.

The undersigned Property Owner has read and understands the terms of this agreement and upon installation of the lighting provided for herein, he/she and all successors shall be obligated hereunder, and any other verbal agreement of any type between the parties is merged into this agreement.

Upon payment in full of all amounts owing hereunder, this agreement shall become null and void, and the City shall record a release hereof upon request.

DATED on the day and year first above written.

STATE OF UTAH)
 ss.
County of Washington)

SUBSCRIBED AND SWORN to before me this ___ day of ____, 19__.

My commission expires:

SECTION 7

POWER SYSTEM

7.1 INTRODUCTION. This section covers the specifications for off-site improvements for power system construction and defines the materials and practices required. Policies and procedures relating to electrical construction and maintenance practices are outlined in the “City of Toquerville Underground Power Construction Standards and Specifications”. Where conflict exists between these and said standards, said standards shall govern.

All materials and equipment shall be furnished by the Contractor and shall be installed in a workmanship like manner in compliance with the current edition of the National Electrical Code and the National Electric Safety Code. Where code conflicts occur, these specifications and local regulations will govern.

7.2 ELECTRIC SERVICES.

7.2.1 POWER CONNECTION. Only authorized employees of the Power Department will be permitted to connect, or disconnect, electrical service to, or from, their power lines.

7.2.2 ELECTRIC SERVICE AGREEMENT. Each applicant for electric service within the municipal power service area must sign a standard electric service agreement. The applicant must supply the required information relating to the amount of load, voltage required, phase required and the purpose for which the service will be used. In the absence of a signed agreement, the acceptance of electric service will be deemed as constituting acceptance of the Power Department requirements and regulations. Large industrial, and/or commercial customers shall contract with the Power Department to meet their special requirements.

7.2.3 CUSTOMER SERVICE FACILITIES. The Customer shall provide and install an approved meter socket having the proper terminal arrangement and capacity to adequately accommodate their service requirements. The Customer shall also extend the building wiring from the meter socket to the service attachment. The Customer shall provide an adequate and substantial means by which Power Department personnel can attach appropriate service line equipment to the building. All service attachments shall have a minimum clearance of ten feet above the ground level, or above other areas where people could come in contact with the power lines.

Ample space shall be provided around the meter attachment to permit an unobstructed area for meter installation and maintenance. A minimum space of three inches shall be left between each meter socket and between meter sockets and other equipment. All equipment on the load side of the building service attachment, (except the meter and metering equipment, which will be furnished by the Power Department) shall be the

responsibility of the Building Owner. All building wiring shall conform to applicable wiring codes.

The Customer shall be responsible for providing adequate and proper equipment to protect their equipment against overload, over or under voltage, or phase failure. The Power Department takes reasonable precaution to prevent any abnormal condition, but does not guarantee that such conditions will not occur. Any proposed change in existing meter, or service locations, or conditions, must be approved by the Power Department or service may be discontinued.

7.3 MATERIALS AND WORKMANSHIP. All materials and workmanship shall be first quality in every respect, plumb and true, and comply with the specific requirements of the approved layout drawings. The previously referenced Power Department standards will be adhered to.

No work shall be embedded in concrete, backfilled, or otherwise covered or concealed, until it has been inspected and approved by Power Department personnel. If any portion of the completed system fails to operate satisfactorily due to defects in material or workmanship, within one year of acceptance, it shall be corrected at the Customer's expense to the satisfaction of the City's Representative.

7.4 CONTROL OF GROUND WATER. All trenches shall be kept free from water during excavation, fine grading, cable laying, and embedment operations. Where the trench bottom is mucky or otherwise unstable because of the presence of ground water, and in cases where the static ground water elevation is above the bottom of any trench excavation, such ground water shall be lowered to the extent necessary to keep the trench free from water and the trench bottom stable when the work within the trench is in progress. Surface water shall be prevented from entering the trenches.

7.5 EXCAVATION AND BACKFILL. Excavation of trenches shall be as shown on approved layout drawings. The City's Representative(s) shall have the right to direct field changes where, in his judgment, alignment or topography problems are evident. Trenches shall be straight and the bottom free from water. All blocking or shoring materials shall be removed during backfill procedures.

Where trenching is required in dedicated streets, or other public rights-of-ways, all trenches shall be backfilled in compliance with these specifications. The developer shall assume full responsibility for street failure where trenching operations have been performed.

Where soil conditions require bedding material, sand shall be placed above and below direct buried cables, or conduits, in two backfill operations. The trench shall then be compacted to ninety (90) percent of relative maximum dry density, unless the trenches are in streets or other public rights-of-ways, where they shall be compacted to a minimum of ninety five (95) percent of relative maximum dry density for granular soils and ninety (90) percent for fine grain soils as detailed in these specifications.

Bedding material specifications shall be as follows:

SAND: Sand shall be well graded, have rounded to sub-rounded particles with one hundred (100) percent of the material passing a three-eighth (3/8) inch sieve, and no more than twenty (20) percent passing a number two hundred (200) sieve. No open graded material, such as "pea gravel" will be permitted for cable bedding. The material shall be non-plastic as per ASTM D-432 and D-424, and the cable shall be embedded with a minimum depth of four (4) inches of sand below the cable and a minimum depth of eight (8) inches of sand over the cable.

7.6 CONCRETE. All concrete poured in the field shall be ready-mixed and shall meet the requirements of these specifications, unless otherwise permitted by the City's Representative.

7.7 METERS. To permit access to the metering installation and to provide working safety for personnel, a clear working and standing space shall be provided in front of all meters. This area shall be located entirely on the Customer's property. The working space shall be kept clear and unobstructed, and shall extend a minimum of three feet from the face of the meter socket or instrument transformer compartment. The working space shall be sufficiently wide to permit ready access to the complete metering installation and in no case shall it be less than three feet wide, and have a height clearance of no less than six feet.

For each meter, the Customer shall furnish and install a switch or other approved disconnecting device. The disconnecting device shall be installed on the load side of the meter and shall control all of, and only the energy registered by that meter.

All meters and enclosures for meters, metering equipment and service entrance equipment on the line side of the meter, shall be sealed only by the Power Department personnel. Seals shall not be broken except by an authorized representative from the Power Department. No person shall be permitted to tamper with, or in any way interfere with a meter or its connections, as placed by the Power Department.

For reasons of public safety, maintenance of service, and reliability of metering; meters shall not be installed in the following areas:

1. In any location that is not readily accessible.
2. In any location which is hazardous to personnel.
3. On any surface subject to excessive vibration.
4. In any elevated or depressed area that does not have access provided by means of a ramp or clear stairway of normal tread and which conforms to building code requirements.
5. In any substation area or transformer vault.
6. In common areas with dogs.

City of Toquerville
Standard Drawing Index

SECTION 1-ROADWAY	<u>No.</u>
<u>CURB, GUTTER, DRIVEWAY, SIDEWALK</u>	
Standard Curb & Gutter Details (HB30-7 & HB30-8)	100
Concrete Curb & Gutter (RU30)	101
Driveway Curb (Type HB30-7) Details	110
Driveway Apron Details	111
Standard Driveway Bridge	112
Standard Sidewalk Details	120
Handicap Ramp Details	121
Standard Concrete Joint Details	122
<u>ROADWAYS</u>	
Standard Road Cross Sections	140
Rural Cross-Section Details	142
Standard 6' Cross Gutter	150
Standard 8' Cross Gutter	151
Driveway Access Details-Large Lot Subdivision	152
Driveway Access Without Curbing (50' & 60' Right of Way)	153
<u>SURVEY MONUMENT</u>	
Class I Standard Monument Details	160
Class II Monument	161
<u>MISCELLANEOUS</u>	
Trench Backfill and Repair Detail	170
Manholes & Valve Boxes Concrete Collar	171
SECTION 2-STORM DRAIN & SANITARY SEWER	
<u>CATCH BASINS, INLETS, OUTLETS AND HARDWARE</u>	
Standard Catch Basin Box & Frame	200
Catch Basin Grate (Non-Bicycle Safe)	201
Standard Catch Basin Grate (Bicycle Safe)	202
39" Solid Lid Details	203
Sidewalk Drainage Structure	204
Curb Inlet Double Catch Basin	205

SECTION 3-WATER SYSTEMS

Water Meter Box Details	300
Water Meter Box Location Details	301
Standard Fire Hydrant Details	302
Water Meter Setter Details	303
8' or 6" Water Lateral (Connection to Existing Line)	304
3/4" Water Service Connection & Meter	305
Temporary Water Line Thrust Block for Testing Details	306
Standard Tee PVC Restraining System Detail	307
Standard Bends for PVC Restraining System Detail	308
Standard Tee Ductile Iron Restraining System Detail	309
Standard Bend for Ductile Iron Restraining System Detail	310
Standard Dead End/Inline Valve for Ductile Iron Restraining System Detail	311
In-Line Valve/Dead-End on PVC Pipe Detail	312
2" Meter Mechanical Piping Detail	313

SECTION 4-TRAFFIC CONTROL

SIGNING

Standard Street Sign	400
Private Street Signs	401
Sign Designation Form	402
Sign, Post and Installation Details	410
Standard Sign Post & Mounting Details	411
Typical Sign Placement Details	412

NOTES:

- 1- ALL CONSTRUCTION & MATERIALS SHALL CONFORM TO CITY STANDARDS.
- 2- RU30 FOR USE ON CERTAIN RURAL COLLECTOR ROADS ONLY & SHALL BE APPROVED BY THE CITY ENGINEER PRIOR TO ITS USE.
- 3- PR24 FOR USE IN PRIVATE DEVELOPMENTS ON PRIVATE ROADS ONLY.

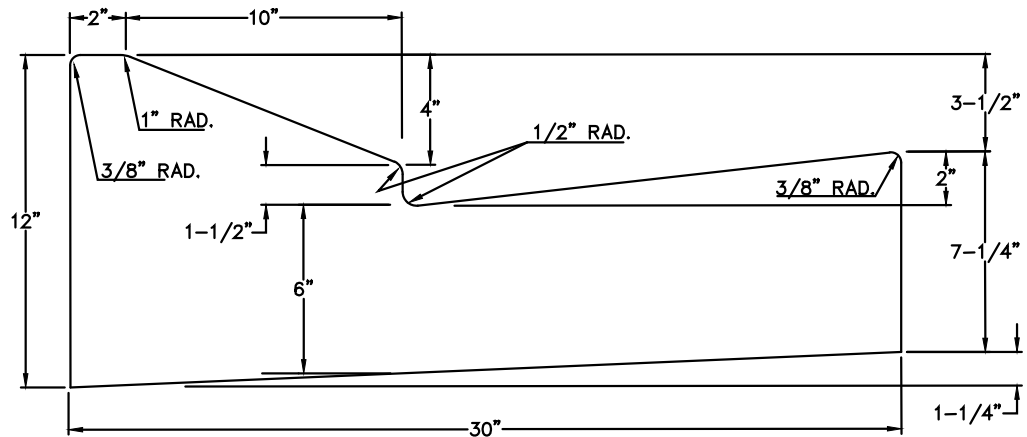

RU30

CITY OF TOQUERVILLE

REVISIONS		
DATE	DESCRIPTION	BY

CONCRETE CURB & GUTTER
(RU30 & PR24)

STANDARD DWG. NO.	
101	1 OF 1
APPROVED:	
DATE: 6/10/96	BY: LBB

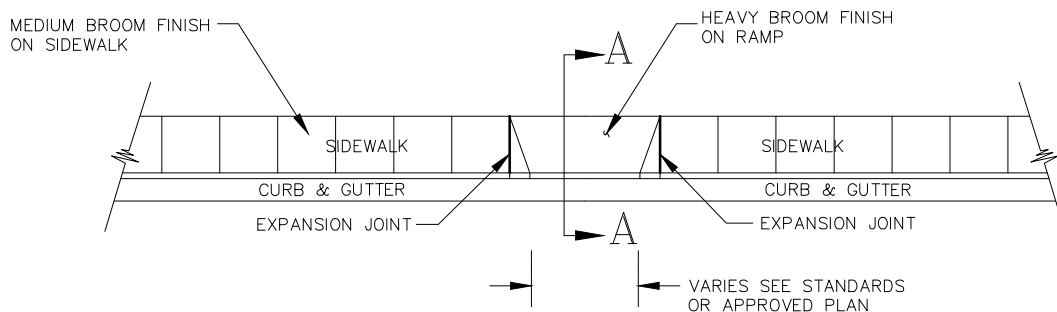

PLAN

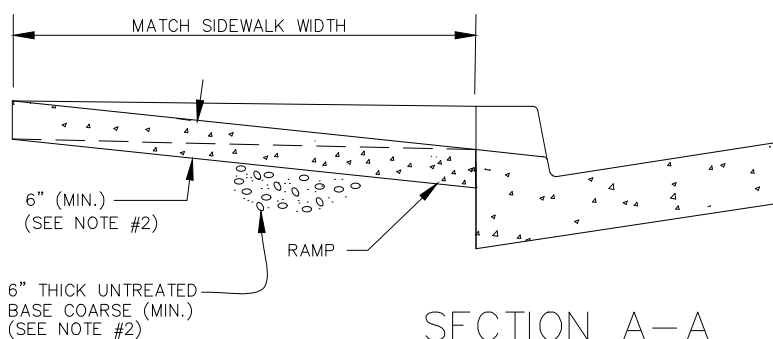

SECTION A-A

NOTES:

- 1- WIDTH OF DRIVEWAYS VARIES WITH USE- SEE CITY STANDARDS OR CONTACT ENGINEERING DEPARTMENT.
- 2- DRIVEWAYS WITH COMMERCIAL OR INDUSTRIAL USE REQUIRE ADDITIONAL THICKNESS. SEE ENGINEERING DEPARTMENT.

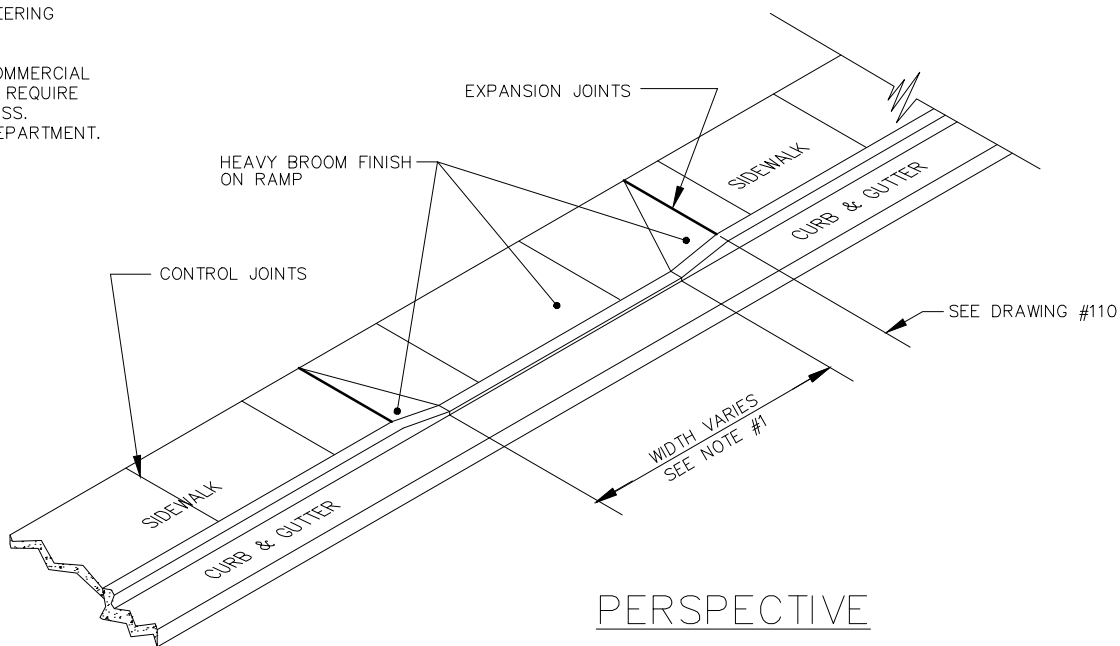

PERSPECTIVE

CITY OF TOQUERVILLE

REVISIONS		
DATE	DESCRIPTION	BY

DRIVEWAY APRON
DETAILS

STANDARD DWG. NO.	
111	1 OF 1
APPROVED:	
DATE:	BY: LBB

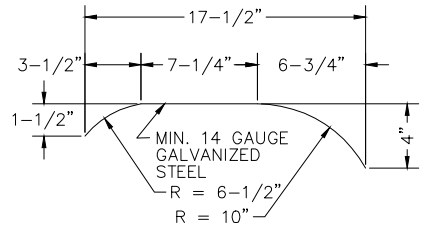
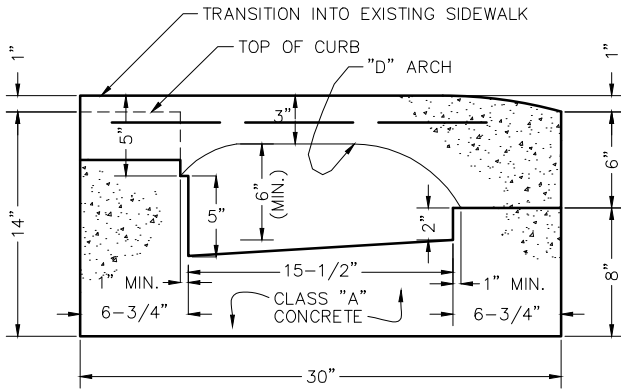

"D" ARCH DIMENSIONS
(APPROXIMATE)

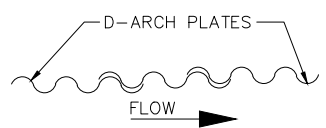

"D" ARCH OVERLAP DETAIL

NOTES:

1. MATCH SIDEWALK AT TOP OF CURB AND TOP OF BRIDGE IN 36" TRANSITION.
2. REBAR AT ENDS REQUIRED
3. ADJUST DIMENSIONS TO FIT IF REQUIRED.
4. DRIVEWAY BRIDGE SHALL BE 5' WIDER THAN DRIVEWAY, DISTRIBUTED 2'-6" ON EACH SIDE OF DRIVEWAY.
- 5- INSTALL ASPHALT RAMP AS REQUIRED.

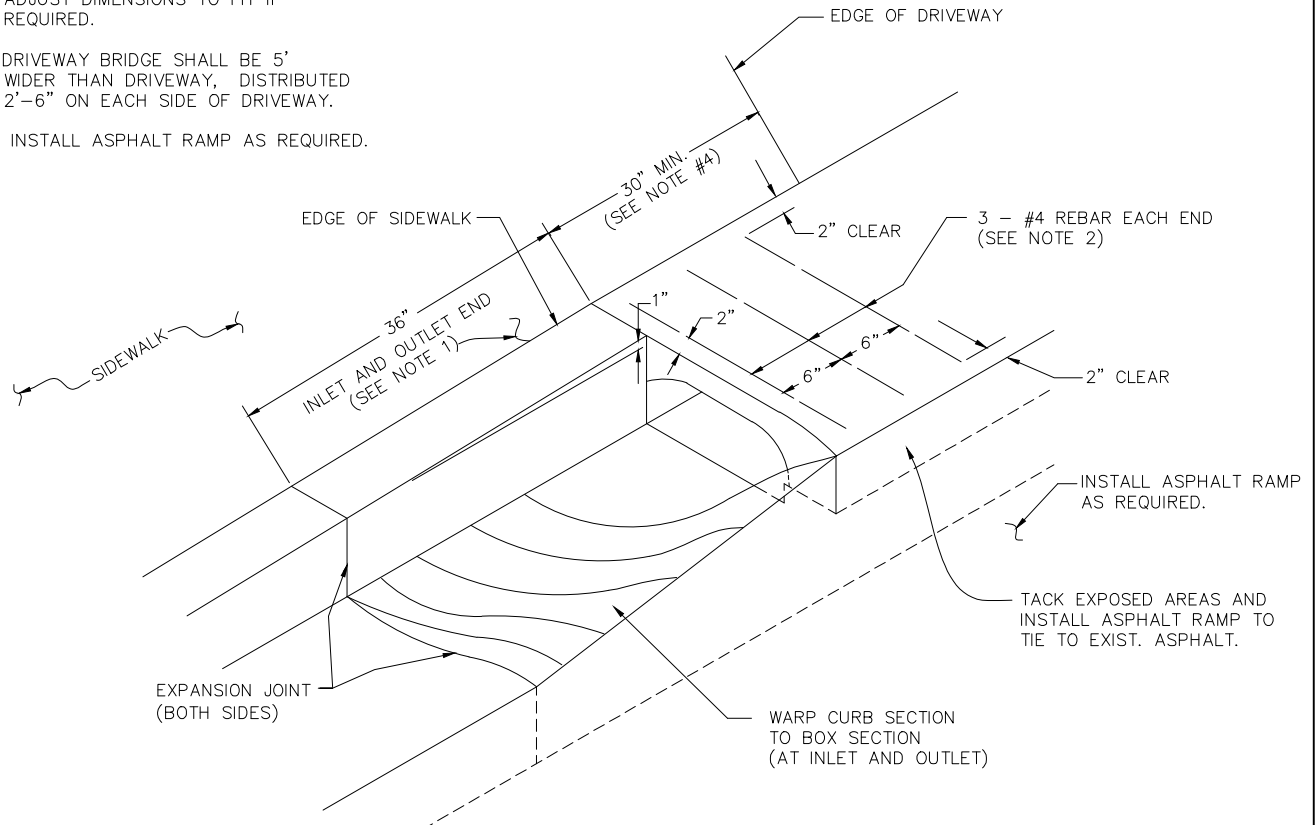

(FOR USE WITH HB 30-8 CURB AND GUTTER ONLY)

CITY OF TOQUERVILLE

REVISIONS		
DATE	DESCRIPTION	BY

STANDARD DRIVEWAY BRIDGE

STANDARD DWG. NO.	
112	1 OF 1
APPROVED:	
DATE:	BY: LBB

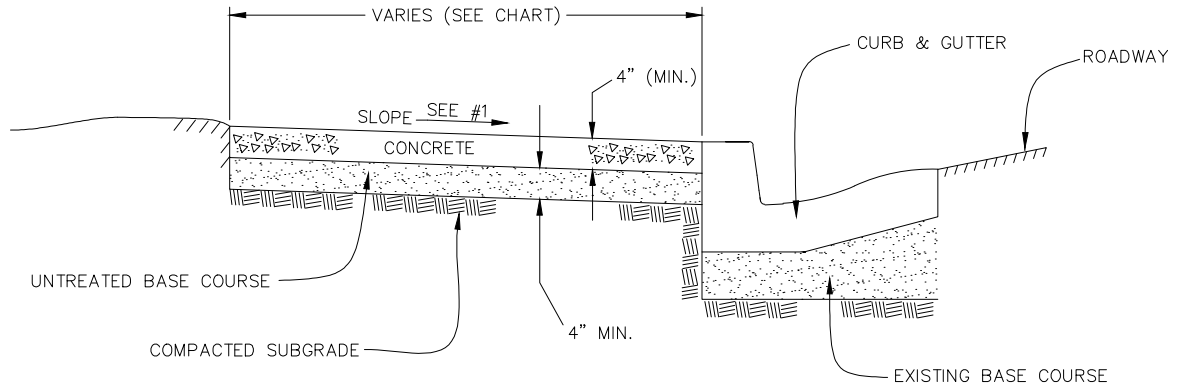

GENERAL NOTES

- 1- CROSS SLOPE SHALL BE 1/4 INCH RISE PER FOOT FROM TOP OF CURB (SLOPE NOT TO EXCEED 1/2 INCH RISE PER FOOT).
- 2- UNTREATED BASE COURSE SHALL BE PLACED UNDER SIDEWALK AND COMPACTED TO A MIN. OF 95%. THICKNESS OF UNTREATED BASE NOT LESS THAN 4 INCHES.
- 3- USE CLASS "A" CONCRETE ONLY (6 BAG, TYPE V CEMENT).
- 4- SIDEWALK SURFACE TO HAVE A MEDIUM BROOM FINISH.
- 5- SIDEWALKS IN COMMERCIAL ZONES SHALL BE A MIN. OF 7' WIDE WHERE DESIGNATED BY THE CITY.
- 6- WHERE SIDEWALKS CROSS DRIVEWAYS, MINIMUM THICKNESS SHALL BE AS FOLLOWS:
RESIDENTIAL: 6" FOR SIDEWALK, 6" FOR ROADBASE
COMMERCIAL/INDUSTRIAL: 8" FOR SIDEWALK, 8" FOR ROADBASE.
- 7- FIBER EXPANSION JOINTS SHALL BE PLACED AT BOTH ENDS OF DRIVEWAY
- 8- FIBER EXPANSION JOINTS SHALL ALSO BE PLACED BETWEEN DRIVEWAY AND BACK OF SIDEWALK.

SIDEWALK	ROAD TYPE				
	LOCAL	COLLECTOR	MAJOR COLLECTOR	ARTERIAL	MAJOR ARTERIAL
WIDTH	4'	5'	5'	5'+	6'+
SCORE JOINT SPACING	4'	5'	5'	5'+	6'+
EXPANSION JOINT SPACING	20'	20'	20'	20'	24'

REVISIONS			CITY OF TOQUERVILLE		STANDARD DWG. NO.		
DATE	DESCRIPTION	BY	STANDARD SIDEWALK DETAILS			120	1 OF 1
						APPROVED:	
						DATE:	BY: LBB

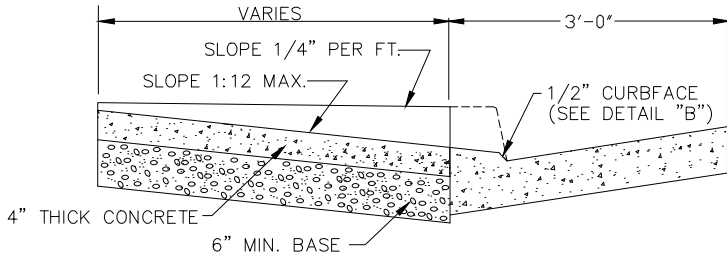

SECTION A-A

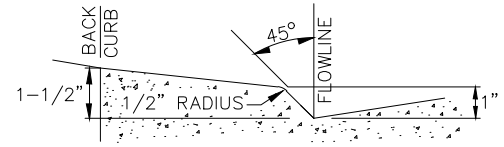

CURBFACE DETAIL B

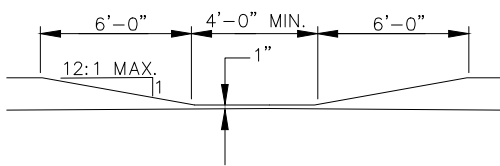

ELEVATION

NOTES:

- 1- POUR CURB & GUTTER SEPARATELY FROM RAMP SIDEWALK.
- 2- RAMPS SHALL BE LOCATED AT MIDPOINT OF CURB RETURN UNLESS OTHERWISE APPROVED.
- 3- MAXIMUM RAMP SLOPE IS 12:1.
- 4- RAMPS SHALL HAVE A ROUGH BROOM FINISH TRANSVERSE TO SLOPE OF THE RAMP.
- 5- RAMP SHOWN IS FOR HB30-7 CURB & GUTTER ONLY- ADJUST OTHERS AS NECESSARY TO MEET MAXIMUM ALLOWABLE SLOPE.

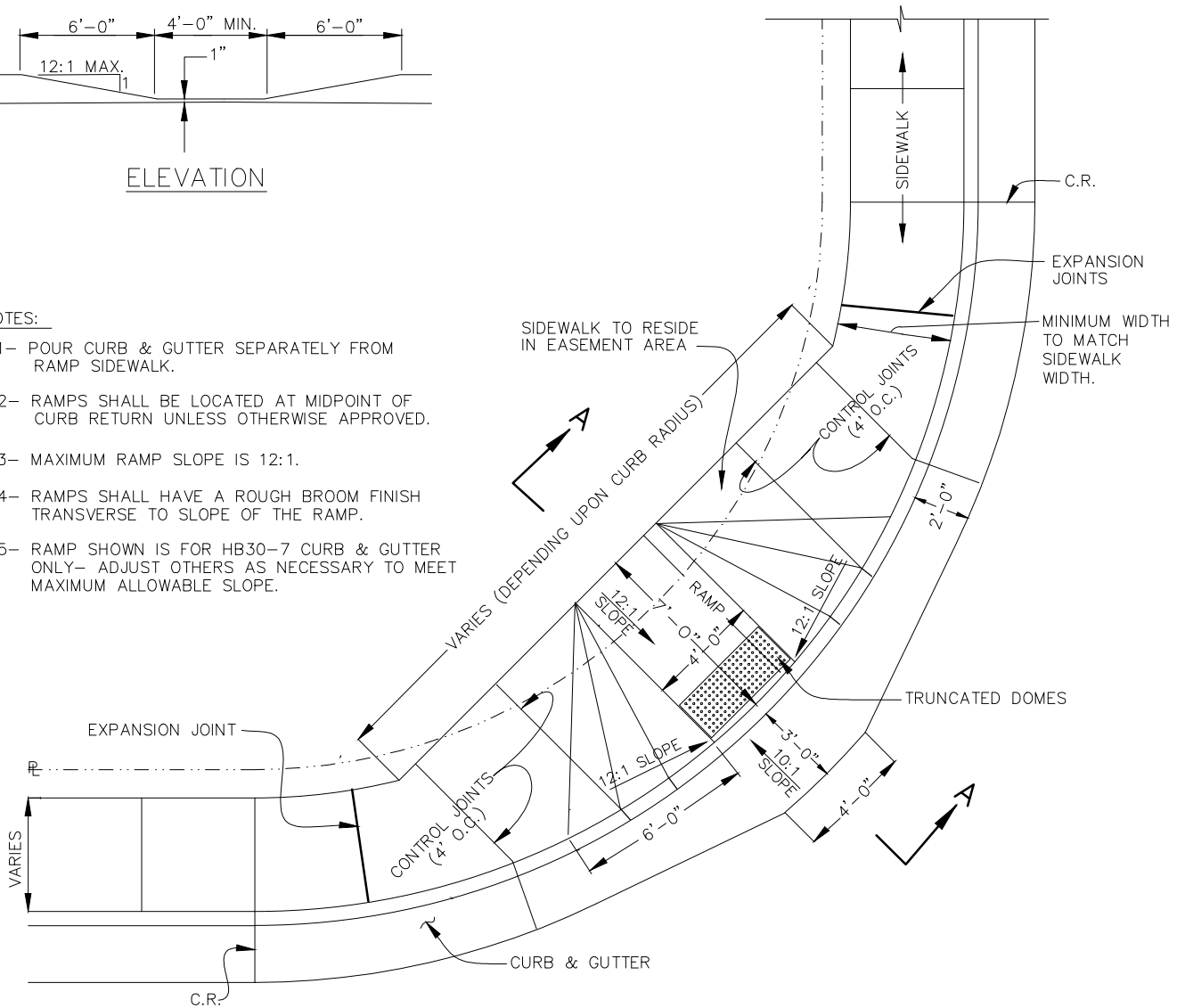

CITY OF TOQUERVILLE

HANDICAP RAMP
DETAILS

STANDARD DWG. NO.

121 1 OF 1

APPROVED:

DATE: BY: LBB

REVISIONS		
DATE	DESCRIPTION	BY

TOP OF JOINT MATERIAL SET FLUSH WITH SURFACE OF CONCRETE. (MAX. INDENT 1/8")

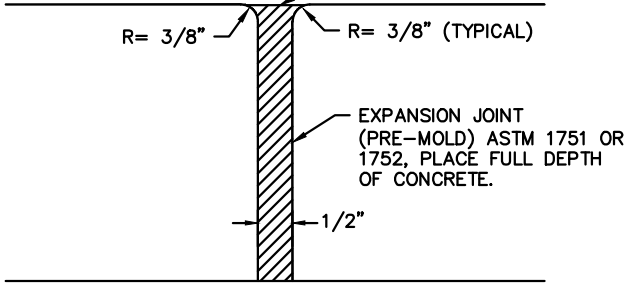

EXPANSION JOINT

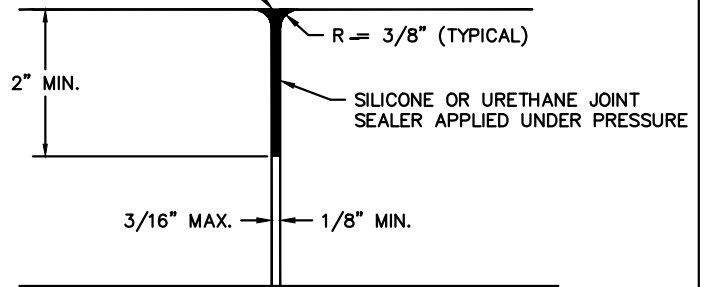

FORM PLATE JOINT

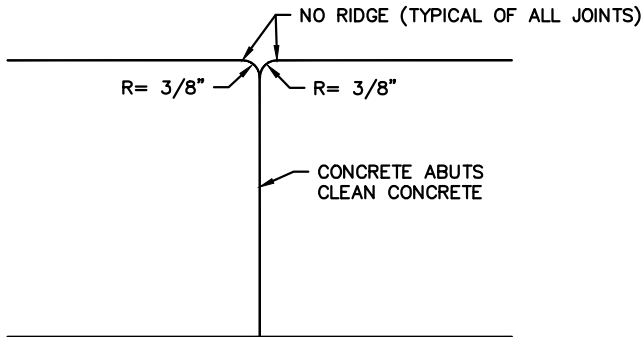

COLD JOINT

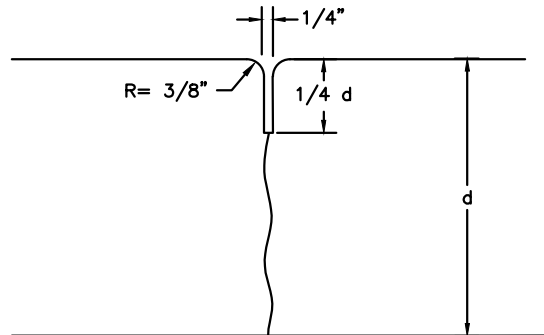

CONTROL JOINT

CITY OF TOQUERVILLE

REVISIONS		
DATE	DESCRIPTION	BY

STANDARD CONCRETE JOINT
DETAILS

STANDARD DWG. NO.	
122	1 OF 1
APPROVED:	
DATE:	BY: LBB

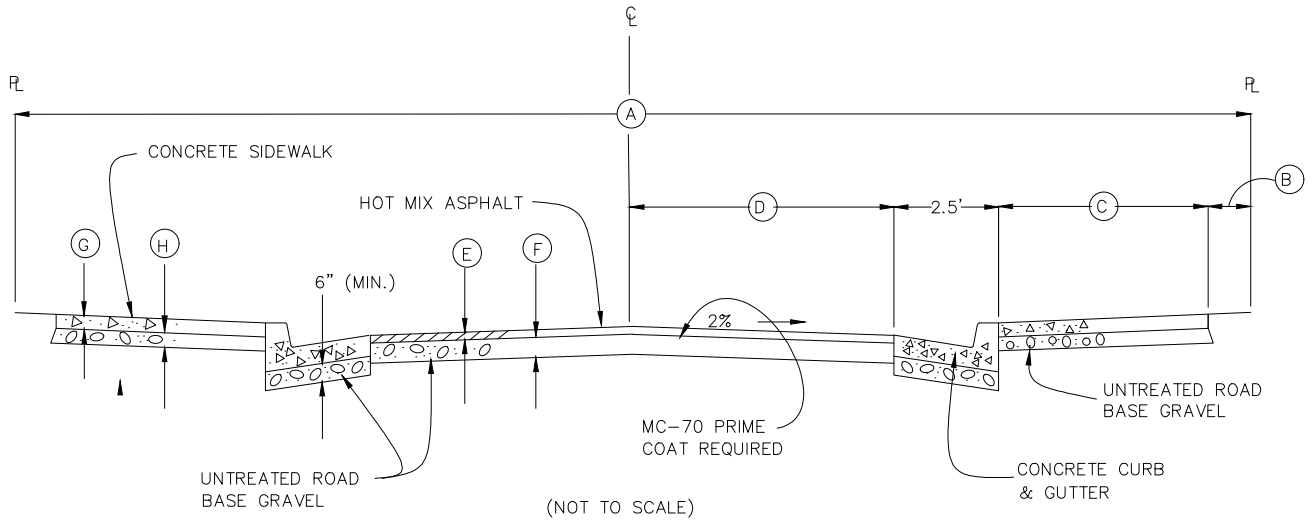

DIMENSIONS					
MARK	LOCAL	COLLECTOR	MAJOR COLLECTOR	ARTERIAL	MAJOR ARTERIAL
A	50'	60'	66'	80'	>80'
B	1'	0'	0.5'	0'	VARIES
C	4'	5'	5'	5'+	6'+
D	17.5'	22.5'	25'	32.5'	>32.5
E(MIN)	2.5"	3"	3"	3.5"	4"
F	SEE STANDARD SPECIFICATIONS				
G	4" FOR SIDEWALK, 6" FOR DRIVEWAY APRONS				
H	4" UNDER SIDEWALKS, 6" UNDER DRIVEWAYS				

NOTES:

- 1- MAXIMUM ALLOWABLE DIFFERENCE IN CURB ELEVATION SHALL BE 12 INCHES AND MUST HAVE CITY ENGINEER APPROVAL PRIOR TO ITS USE.
- 2- FOR ROADS IN OR SERVING INDUSTRIAL AREAS, ASPHALT AND BASE THICKNESS SHALL BE INCREASED ACCORDING TO PROVISIONS FOR HEAVY TRUCK TRAFFIC.
- 3- MINIMUM ASPHALT THICKNESS IS SHOWN. THICKNESS SHALL BE BASED UPON ACTUAL ENGINEERING ANALYSIS, BUT IN NO CASE SHALL IT BE LESS THAN THE MINIMUM.

CITY OF TOQUERVILLE

REVISIONS		
DATE	DESCRIPTION	BY

STANDARD ROAD CROSS SECTIONS

STANDARD DWG. NO.	
140	1 OF 1
APPROVED:	
DATE:	BY: LBB

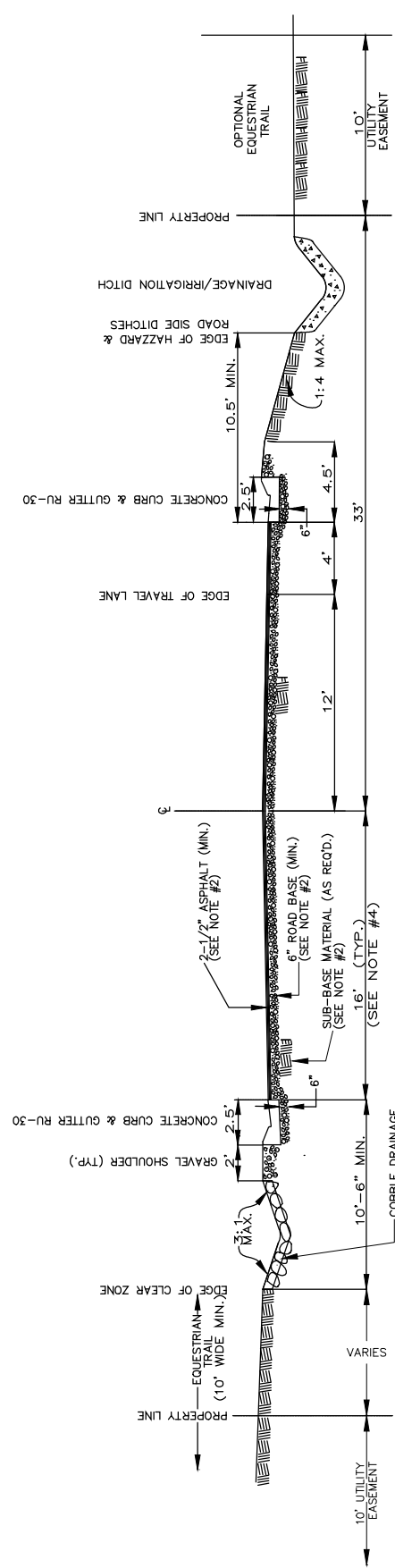

RURAL X-SECTION 66' WIDE MAJOR COLLECTOR

- NOTES:**
- 1- ALL POLES, HYDRANTS, TREES, AND OTHER OBSTRUCTIONS TO BE IN UTILITY EASEMENT AREA
 - 2- DEPTH SHOWN IS A MIN. ACTUAL WILL BE PER ROADWAY DESIGN.
 - 3- USE OF THIS ROAD SECTION REQUIRES PRIOR APPROVAL FROM THE CITY ENGINEER'S OFFICE.
 - 4- ADDITIONAL ROADWAY WIDTH WILL BE REQUIRED AT INTERSECTIONS TO ACCOMMODATE TURNING LANES: LEFT ONLY-12' LEFT AND RIGHT- 22'

CITY OF TOQUERVILLE

RURAL X-SECTION DETAILS

REVISIONS		
DATE	DESCRIPTION	BY

STANDARD DWG. NO.	
142	1 OF 2
APPROVED:	
DATE:	BY: LBB

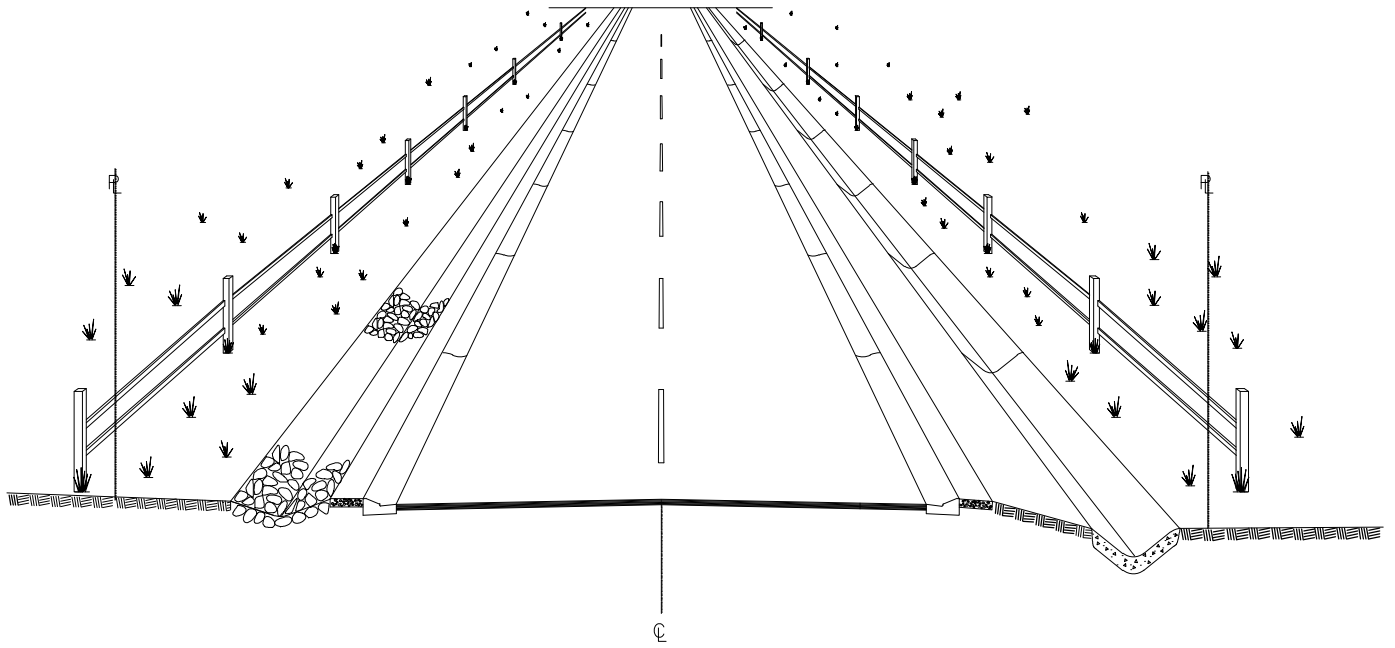

CITY OF TOQUERVILLE

REVISIONS		
DATE	DESCRIPTION	BY

STANDARD DWG. NO.	
142	2 OF 2
APPROVED:	
DATE:	BY: LBB

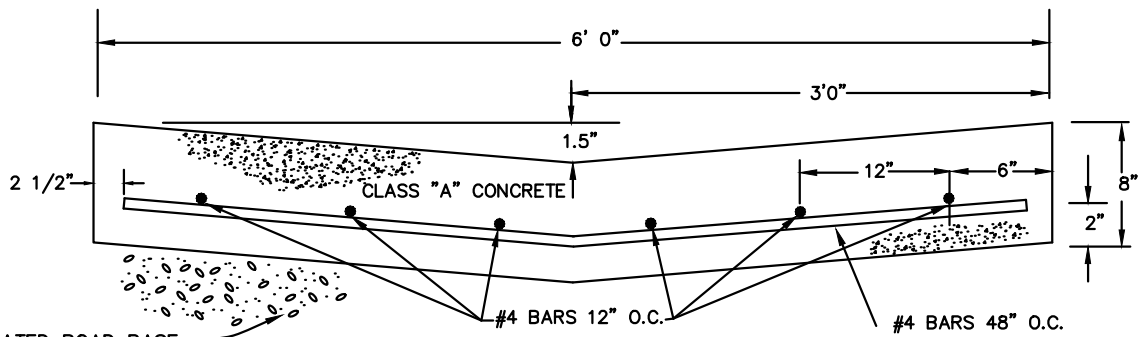

6' CROSS SECTION

UNTREATED ROAD BASE THICKNESS AS REQUIRED (MIN 8") COMPACTED TO 95%.

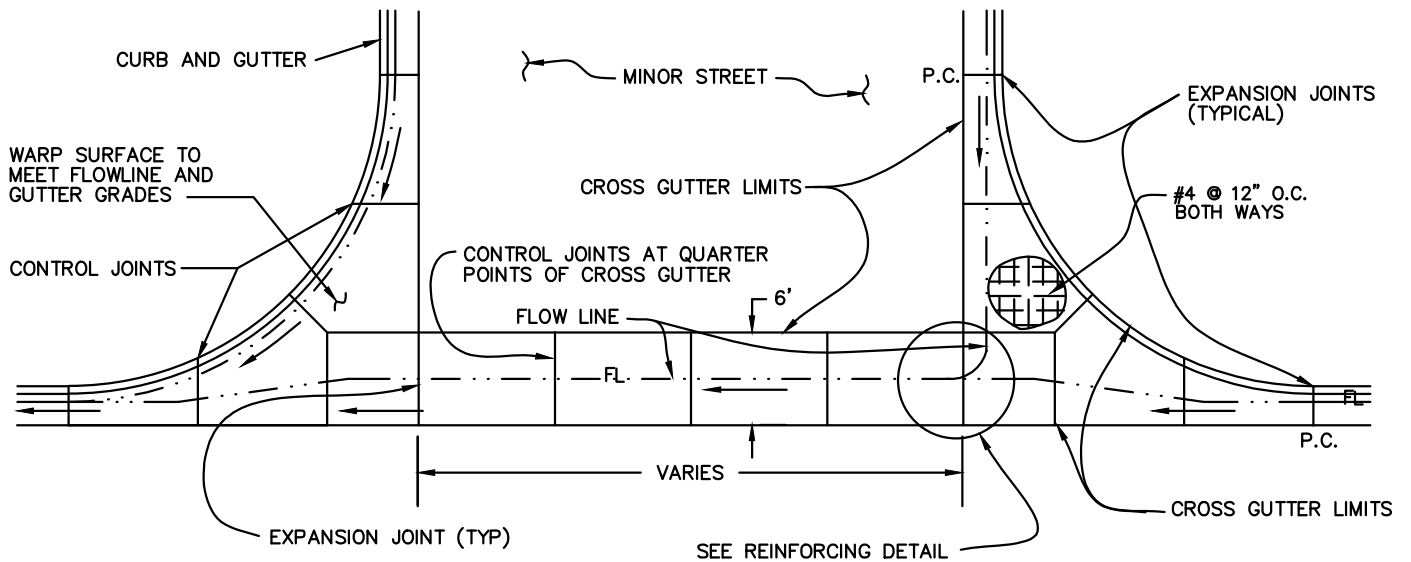

NOTES:

- 1- FOR USE ON RESIDENTIAL & COMMERCIAL STREETS.
- 2- CROSS GUTTERS ARE USED AT INTERSECTIONS ONLY UNLESS OTHERWISE APPROVED.
- 3- CROSS GUTTER SHALL CROSS THE MINOR STREET.
- 4- ALL REINFORCING STEEL SHALL HAVE 2-INCH MINIMUM CLEAR COVER. SUPPORT CHAIRS, BLOCKS OR OTHER APPROVED EQUAL SHALL BE USED TO RAISE STEEL OFF GROUND.
- 5- REINFORCING TO EXTEND TO LIMITS OF CROSS GUTTER.
- 6- ALL REINFORCING STEEL SHALL BE GRADE 60 ASTM A 615.

PLAN

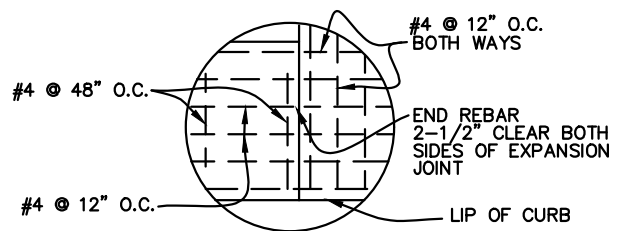

REINFORCING DETAIL

CITY OF TOQUERVILLE

REVISIONS		
DATE	DESCRIPTION	BY

STANDARD 6' CROSS GUTTER

STANDARD DWG. NO.	
150	1 OF 1
APPROVED:	
DATE:	BY: LBB

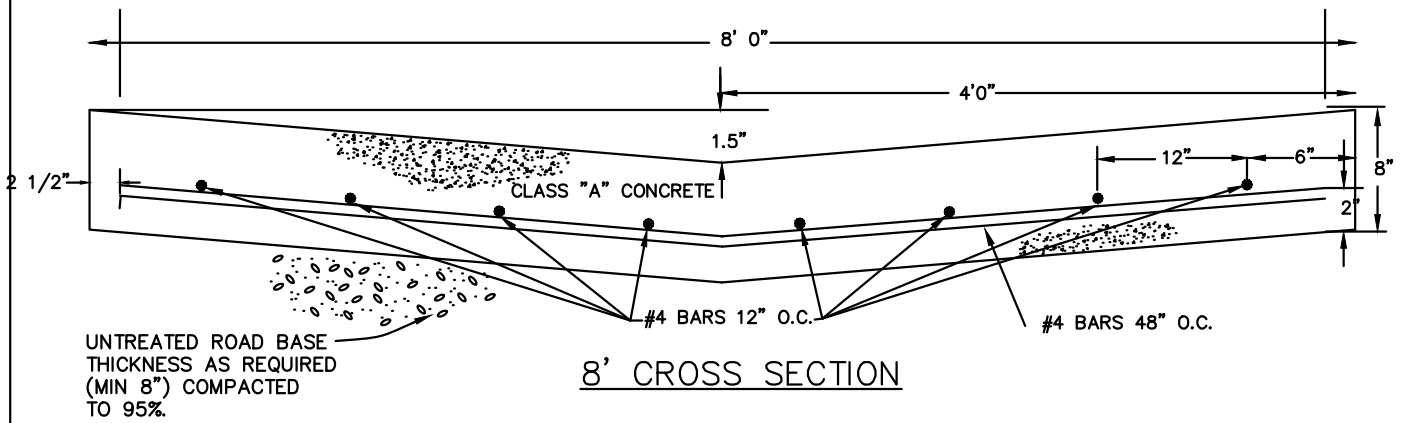

8' CROSS SECTION

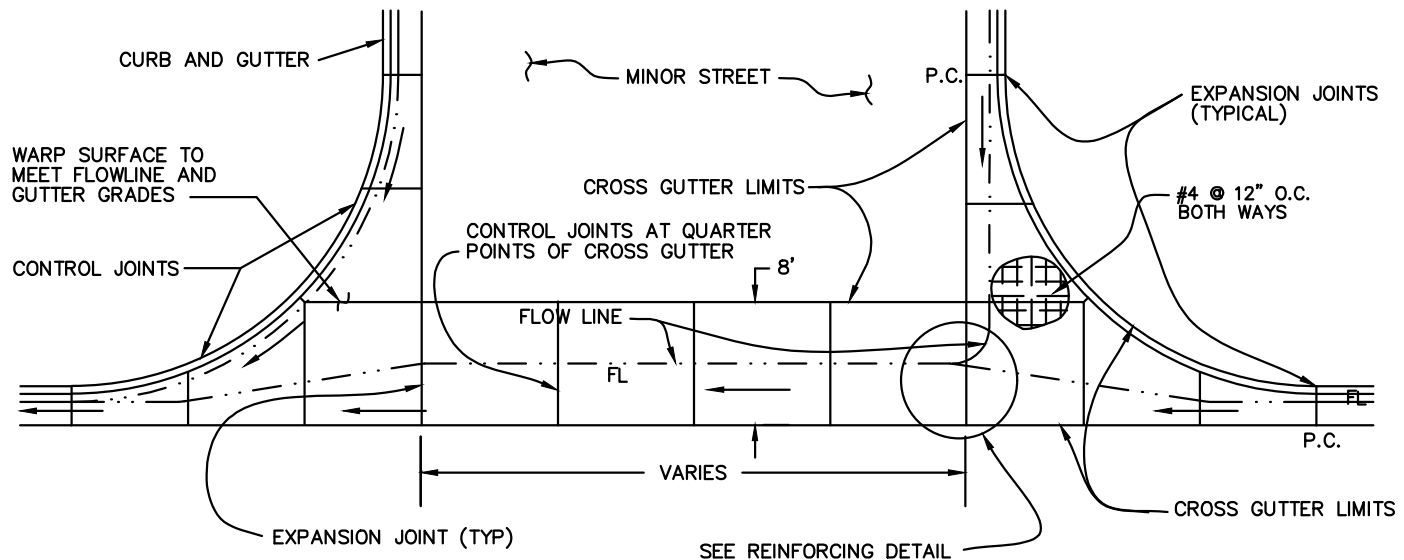

NOTES:

- 1- FOR USE ON RESIDENTIAL & COMMERCIAL STREETS.
- 2- CROSS GUTTERS ARE USED AT INTERSECTIONS ONLY UNLESS OTHERWISE APPROVED.
- 3- CROSS GUTTER SHALL CROSS THE MINOR STREET.
- 4- ALL REINFORCING STEEL SHALL HAVE 2-INCH MINIMUM CLEAR COVER. SUPPORT CHAIRS, BLOCKS OR OTHER APPROVED EQUAL SHALL BE USED TO RAISE STEEL OFF GROUND.
- 5- REINFORCING TO EXTEND TO LIMITS OF CROSS GUTTER.
- 6- ALL REINFORCING STEEL SHALL BE GRADE 60 ASTM A 615.

PLAN

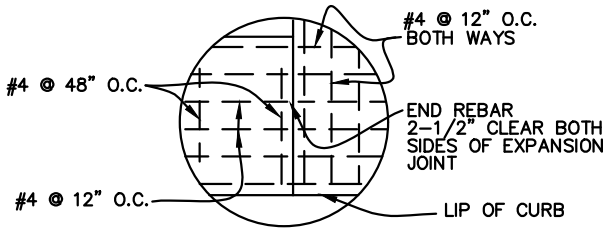

REINFORCING DETAIL

CITY OF TOQUERVILLE

REVISIONS		
DATE	DESCRIPTION	BY

STANDARD 8' CROSS GUTTER

STANDARD DWG. NO.	
151	1 OF 1
APPROVED:	
DATE:	BY: LBB

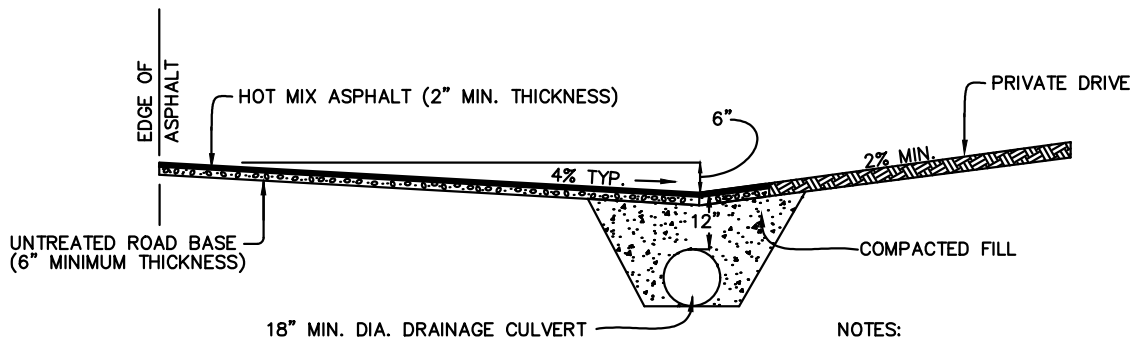

SECTION AT DRIVEWAY ☉

NOTES:

- 1- ALL PIPE AND INSTALLATION TO MEET CITY STANDARDS.
- 2- CULVERT TO HAVE A MINIMUM SLOPE OF 0.5%.
- 3- DO NOT PAVE BETWEEN EDGE OF ASPHALT AND DRAINAGE DITCH EXCEPT AT DRIVEWAY.

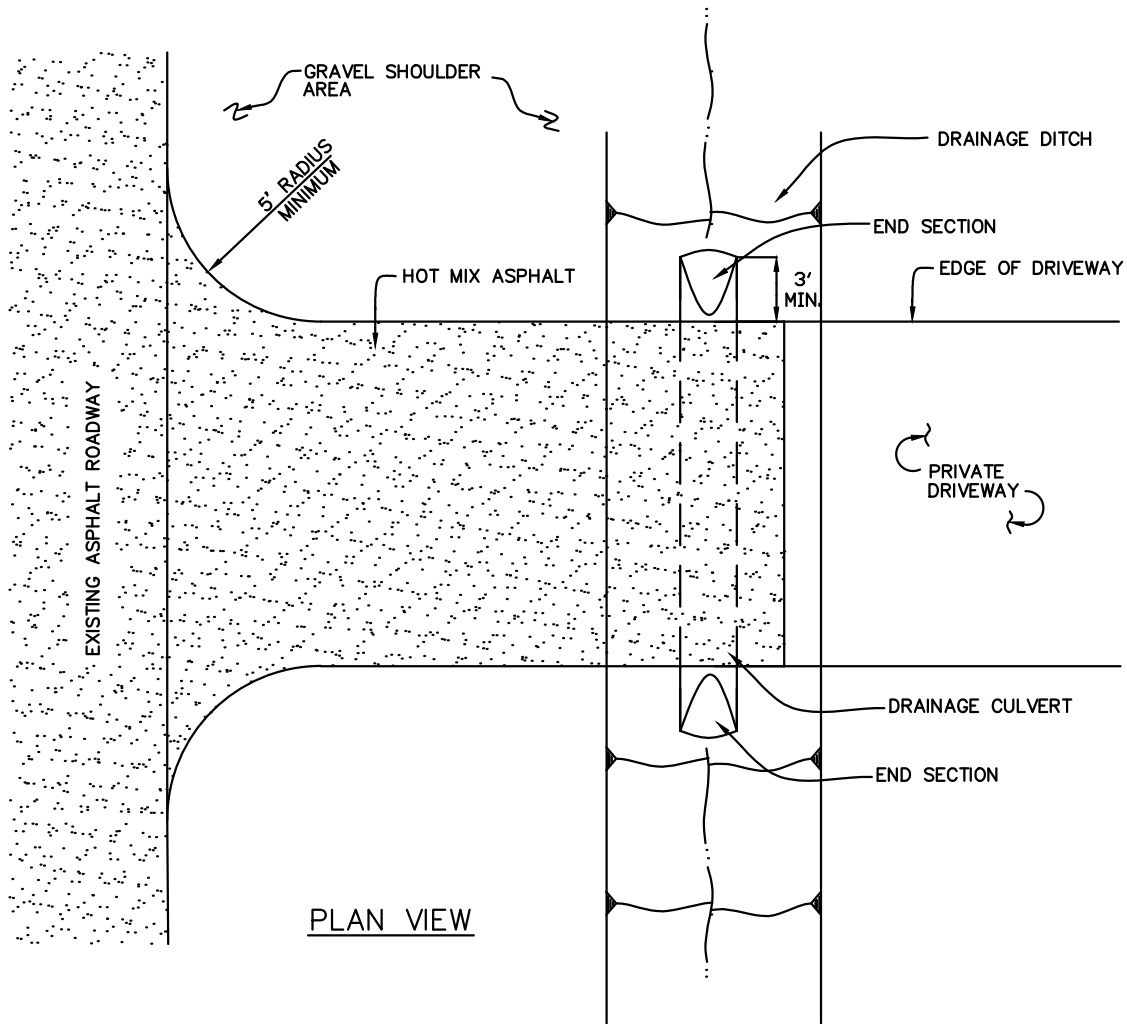

CITY OF TOQUERVILLE

REVISIONS		
DATE	DESCRIPTION	BY

DRIVEWAY ACCESS DETAILS
LARGE LOT SUBDIVISIONS

STANDARD DWG. NO.	
152	1 OF 1
APPROVED:	
DATE:	BY: LBB

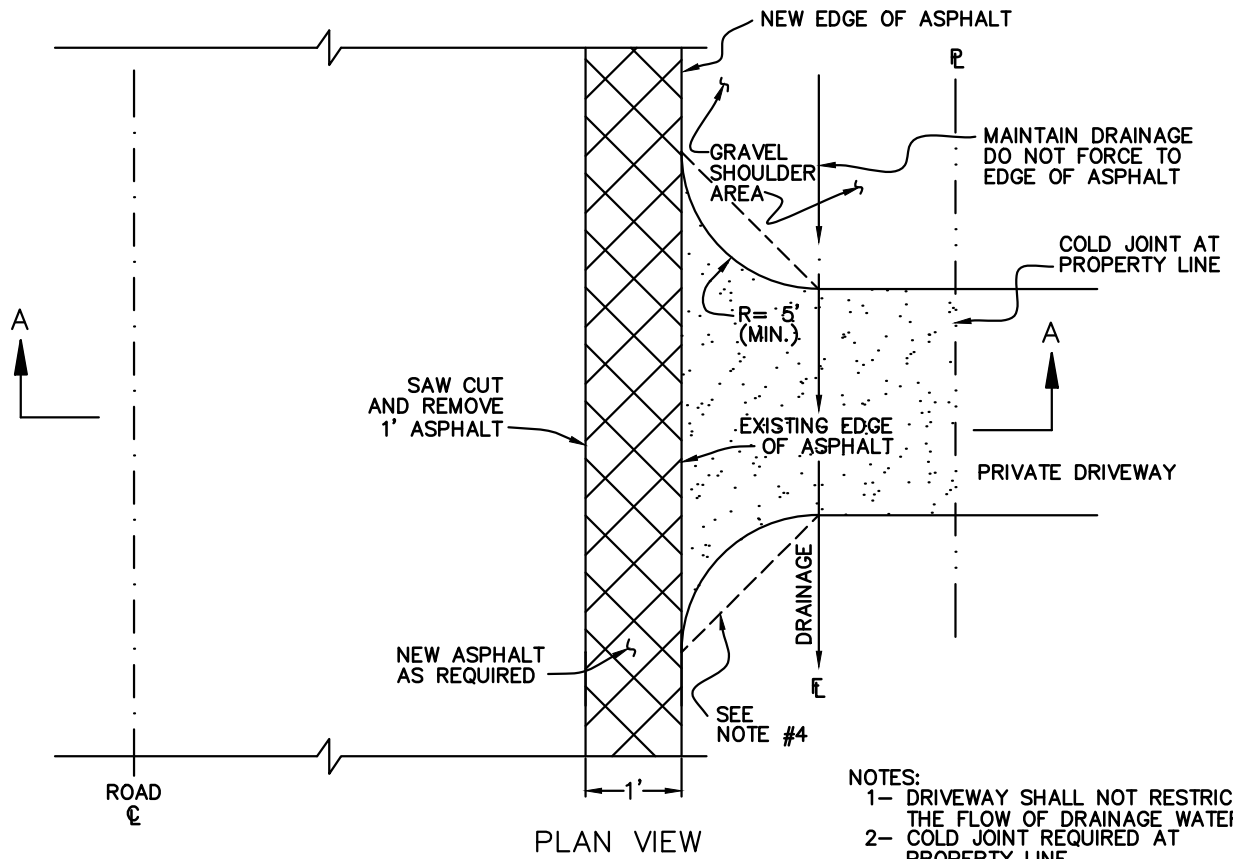

- NOTES:
- 1- DRIVEWAY SHALL NOT RESTRICT THE FLOW OF DRAINAGE WATER
 - 2- COLD JOINT REQUIRED AT PROPERTY LINE.
 - 3- DO NOT PAVE BETWEEN NEW EDGE OF ASPHALT AND DRAINAGE CENTERLINE EXCEPT AT DRIVEWAY.
 - 4- 45° ANGLE MAY REPLACE RADIUS.

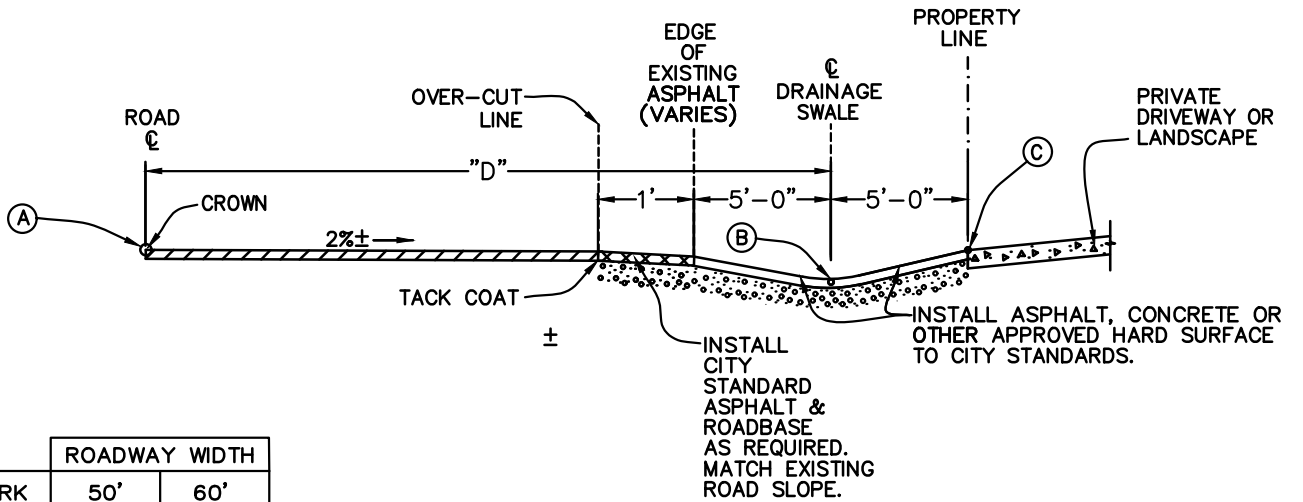

MARK	ROADWAY WIDTH	
	50'	60'
A	VARIES	VARIES
B(MIN.)	A-6"	A-7"
C	A+1"	A+1"
D	20'	25'

SECTION-A

CITY OF TOQUERVILLE

REVISIONS		
DATE	DESCRIPTION	BY

DRIVEWAY ACCESS
WITHOUT CURBING (50' & 60' RIGHT OF WAY)

STANDARD DWG. NO.	
153	1 OF 1
APPROVED:	
DATE:	BY: LBB

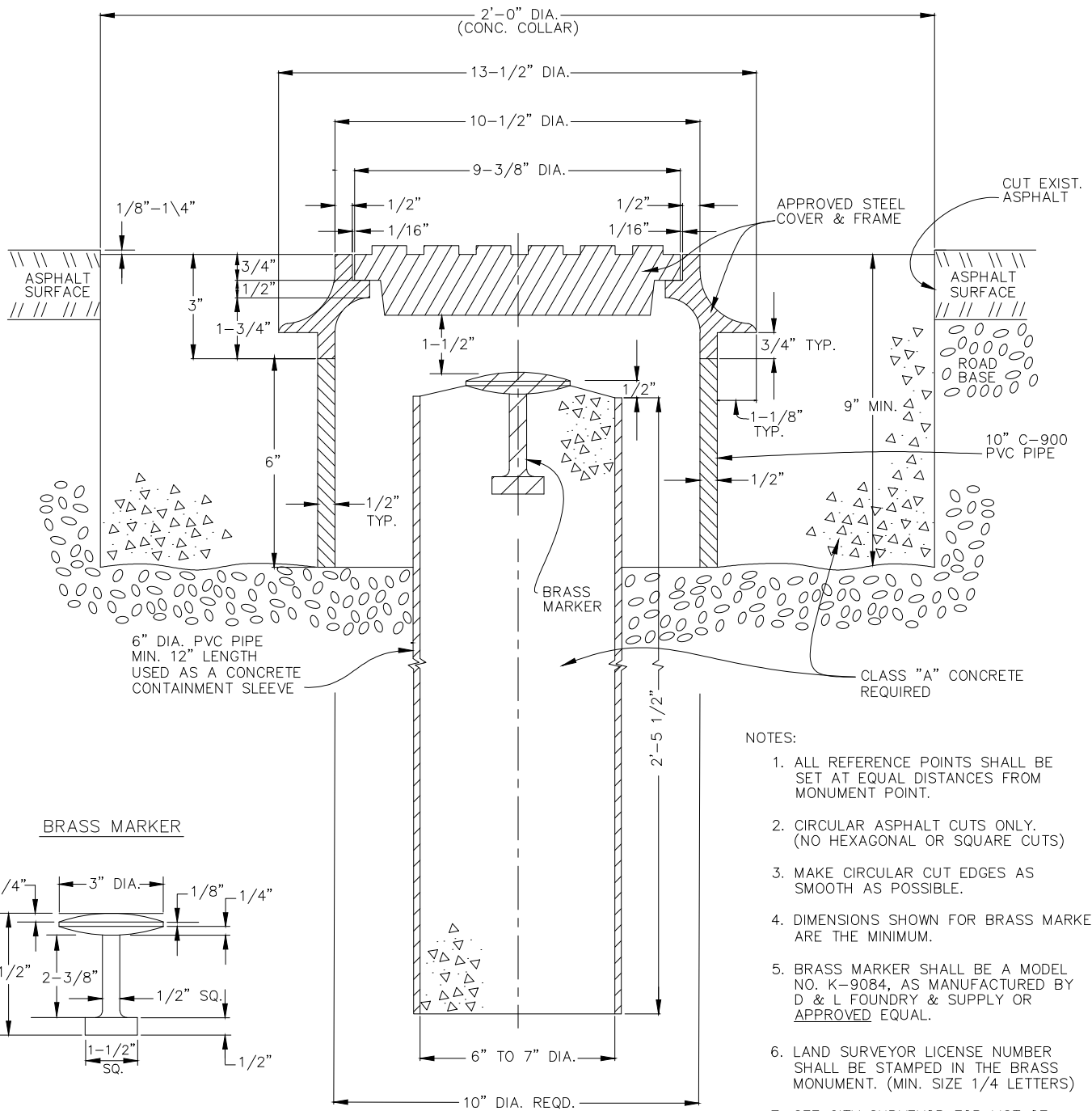

BRASS MARKER

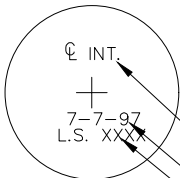
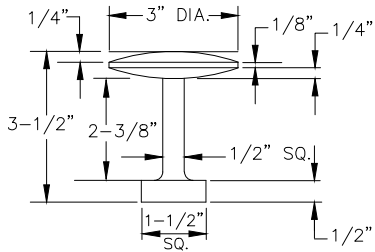

CAP PLAN

ABBREVIATIONS, SEE NOTE #7
 DATE CAP IS MARKED.
 LICENSE NO. OF LAND SURVEYOR MARKING CAP.

NOTES:

1. ALL REFERENCE POINTS SHALL BE SET AT EQUAL DISTANCES FROM MONUMENT POINT.
2. CIRCULAR ASPHALT CUTS ONLY. (NO HEXAGONAL OR SQUARE CUTS)
3. MAKE CIRCULAR CUT EDGES AS SMOOTH AS POSSIBLE.
4. DIMENSIONS SHOWN FOR BRASS MARKER ARE THE MINIMUM.
5. BRASS MARKER SHALL BE A MODEL NO. K-9084, AS MANUFACTURED BY D & L FOUNDRY & SUPPLY OR APPROVED EQUAL.
6. LAND SURVEYOR LICENSE NUMBER SHALL BE STAMPED IN THE BRASS MONUMENT. (MIN. SIZE 1/4 LETTERS)
7. SEE CITY SURVEYOR FOR LIST OF COMMONLY USED ABBREVIATIONS.
8. CONCRETE SURFACE SHALL HAVE A MEDIUM BROOM FINISH.
9. CONCRETE SURFACE SHALL BE 1/8"-1/4" LOWER THAN THE EXISTING ROAD SURFACE.
10. ALL EXCESS CONCRETE SHALL BE REMOVED FROM MONUMENT WELL.

CITY OF TOQUERVILLE

REVISIONS		
DATE	DESCRIPTION	BY
9/02	REVISED CAP	LLB

**CLASS I STANDARD MONUMENT
 DETAILS**

STANDARD DWG. NO.	
160	1 OF 1
APPROVED:	
DATE:	BY: LBB

NOTES:

- 1- TYPE II MONUMENTS TO BE SET AT ALL CENTERLINE CONTROL POINTS NOT OTHERWISE IDENTIFIED BY A TYPE I MONUMENT AND AS REQUIRED BY THE CITY SURVEYOR.
- 2- THE REGISTERED LAND SURVEYOR'S NUMBER, AND A PUNCH MARK ARE TO APPEAR ON THE SURFACE OF THE CAP.
- 3- ALUMINUM CAP SHALL BE SET FLUSH WITH SURFACE OF ROAD.

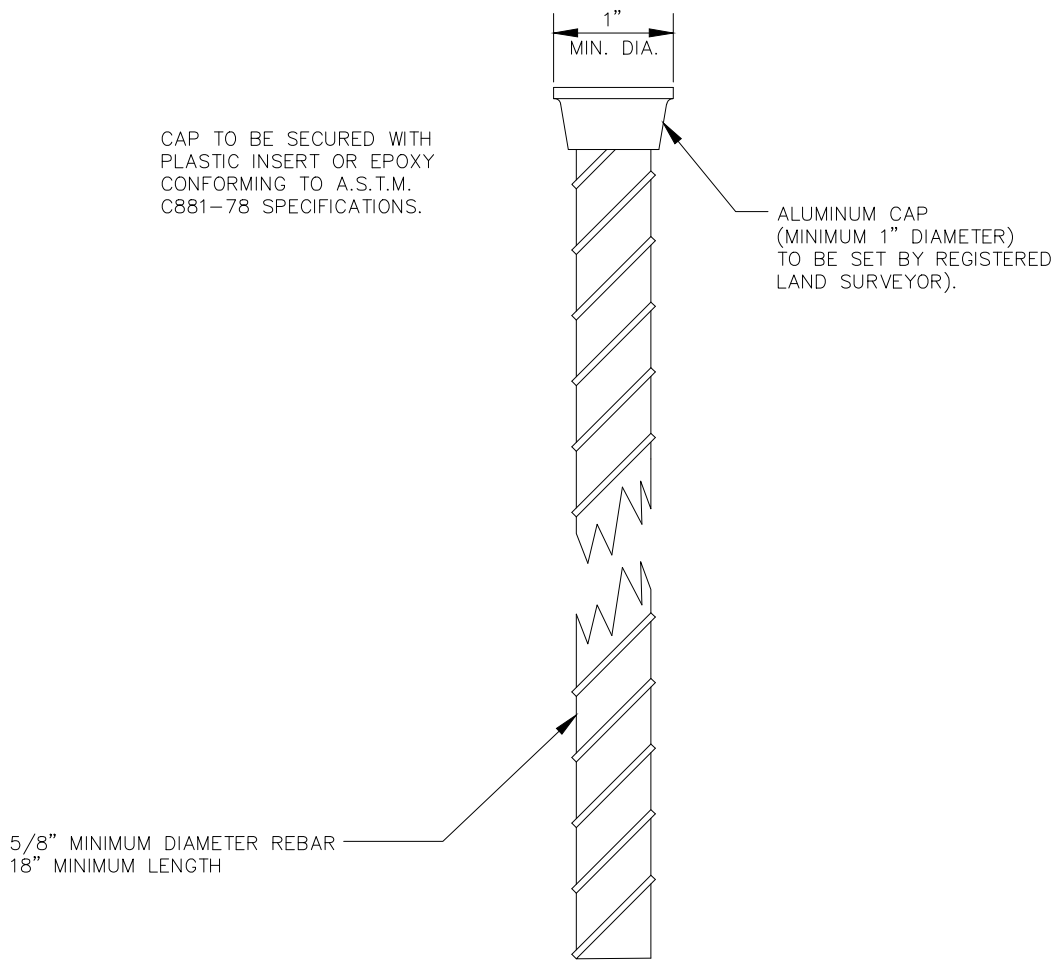

TYPE II MONUMENT

CITY OF TOQUERVILLE

REVISIONS		
DATE	DESCRIPTION	BY

CLASS II MONUMENT

STANDARD DWG. NO.	
161	1 OF 1
APPROVED:	
DATE:	BY: LBB

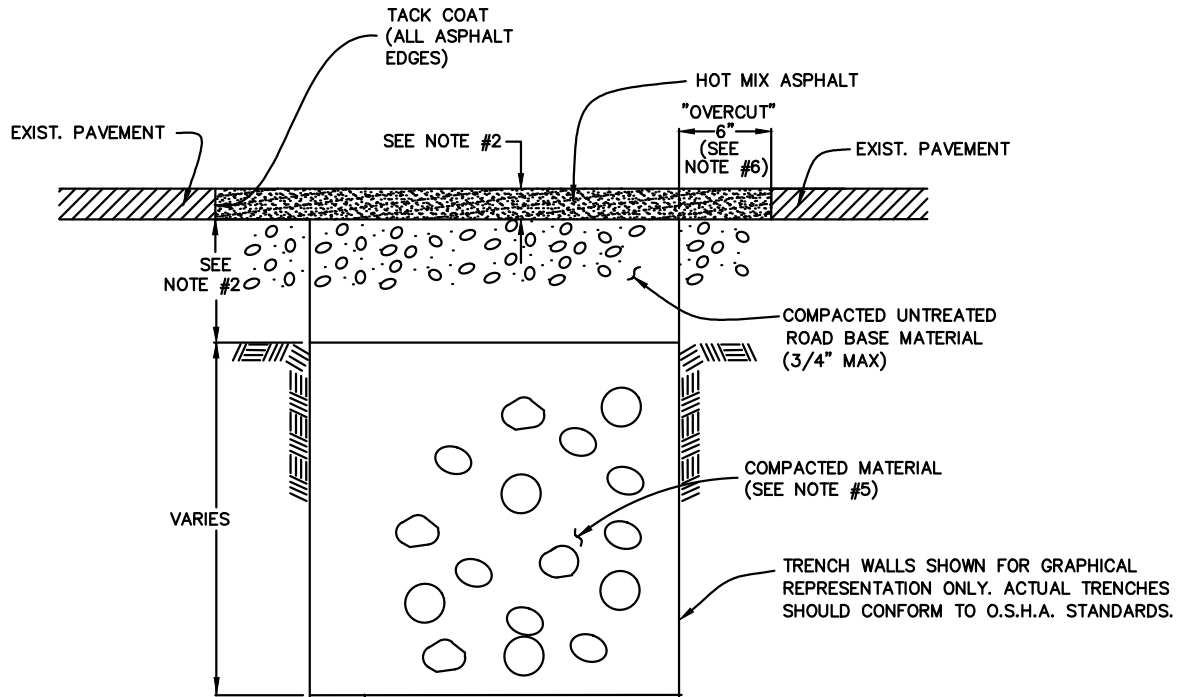

NOTES:

- 1- ALL EXCAVATIONS WITHIN PUBLIC RIGHT-OF-WAY REQUIRE AN ENCROACHMENT PERMIT FROM THE CITY ENCROACHMENT OFFICER.
- 2- MINIMUM THICKNESS OF ASPHALT AND BASE SHALL BE AS OUTLINED IN THE ROADWAY STRUCTURAL REQUIREMENTS. IN NO CASE SHALL THE THICKNESS BE LESS THAN THE EXISTING.
- 3- FOUNDATION MATERIAL SHALL BE USED WHEN TRENCH BOTTOM IS UNSTABLE.
- 4- ALL STATE HIGHWAY CROSSINGS SHALL BE APPROVED BY THE U.D.O.T. DISTRICT ENGINEER (U.D.O.T. PERMIT REQUIRED).
- 5- MINIMUM COMPACTION SHALL BE 95%. WHEN APPROVED FLOWABLE FILL OR SLURRY IS USED COMPACTION TESTING WILL NOT BE REQUIRED.
- 6- WHEN MATERIAL UNDER THE 6" OVERCUT SLUFFS OFF OR IS REMOVED, BASE SHALL BE COMPACTED, TO THE BOTTOM LEVEL OF EXISTING ASPHALT. AN ADDITIONAL 6" IN WIDTH OF ASPHALT SHALL BE CUT, REMOVED AND REPLACED AS PART OF THE OVERALL PATCH.
- 7- WHERE ROAD SECTION HAS A DESIGNED GRANULAR SUB-BASE, IT SHALL BE REPLACED IN KIND OR WITH ROAD BASE GRAVEL.
- 8- IN GENERAL, STREET SURFACES LESS THAN 24 MONTHS OLD WILL NOT BE CUT ! IF A CUT MUST BE MADE, ADDITIONAL, STRICTER REQUIREMENTS MAY BE INVOKED. SEE ENCROACHMENT OFFICER.
- 9- 24 HOUR NOTICE REQUIRED ON ALL INSPECTIONS.
- 10- ALL TRENCH BACKFILL SHALL MEET MIN. COMPACTION REQUIREMENTS.
- 11- EXCLUDING EMERGENCY CLOSURES ALL ROAD CLOSURES AND DETOURS REQUIRE 48 HOURS PRIOR NOTICE.
- 12- WHEN PIPE IS LAID IN ROCK, A 2' SAND BARRIER SHALL SURROUND THE CULINARY PIPE.
- 13- ENSURE A MIN OF 4' SPACE BETWEEN CULINARY AND IRRIGATION LINE WITH 1' VERTICAL DISTANCE BETWEEN TOP OF CULINARY AND BOTTOM OF IRRIGATION PIPE.

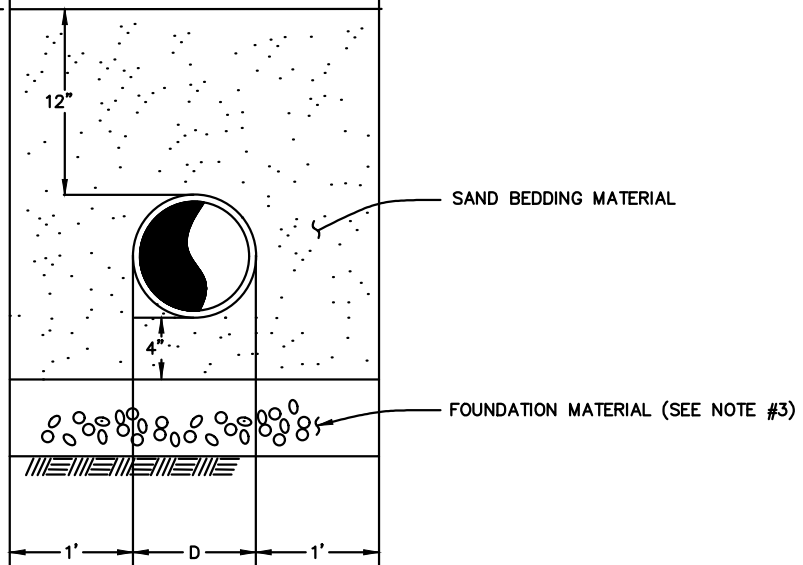

CITY OF TOQUERVILLE

REVISIONS		
DATE	DESCRIPTION	BY

TRENCH BACKFILL AND REPAIR DETAIL

STANDARD DWG. NO.	
170	1 OF 1
APPROVED:	
DATE:	BY: LBB

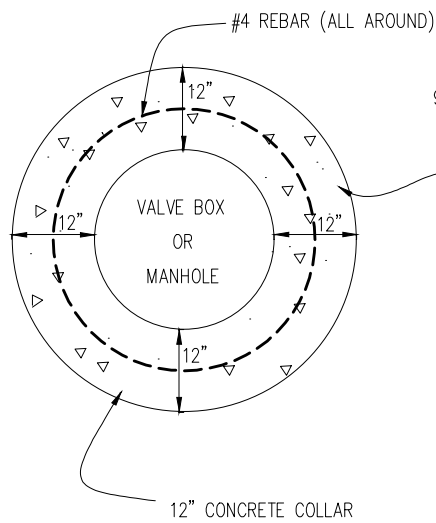

PLAN

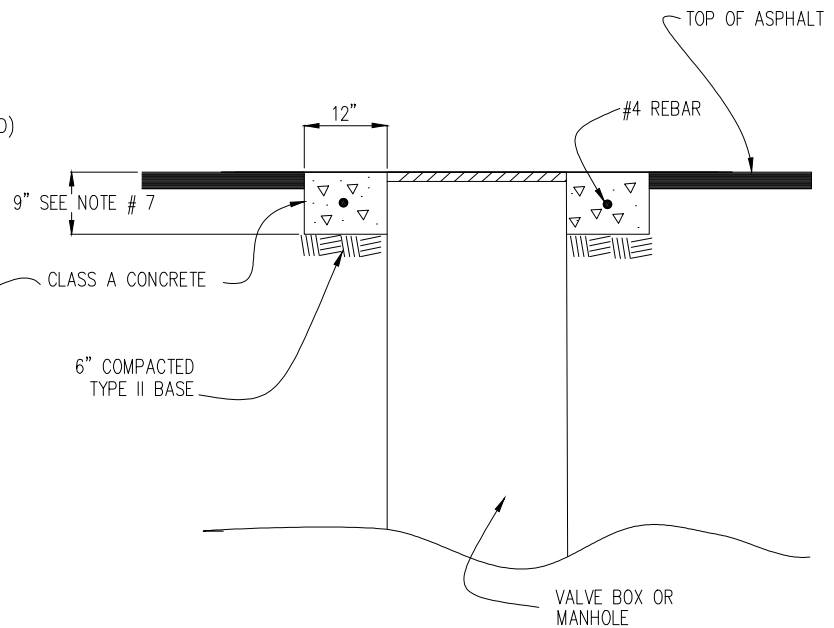

SECTION

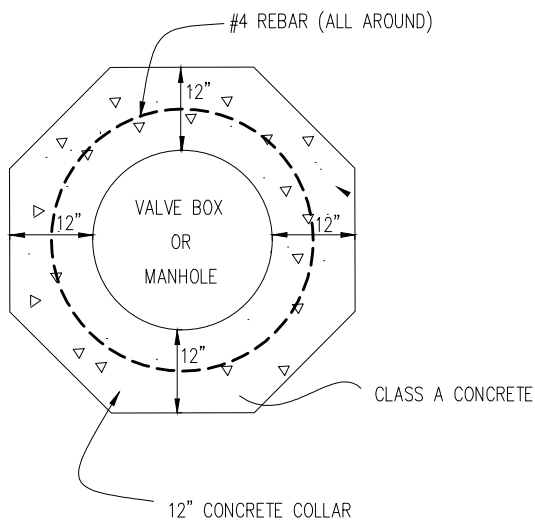

PLAN
OPTIONAL

NOTES:

- 1- MANHOLES, VALVE BOXES AND OTHER SIMILAR ITEMS SHALL BE ADJUSTED TO GRADE AFTER PAVING IS COMPLETE.
- 2- THE SURFACE OF THE ADJUSTED RING SHALL MATCH THE GRADE OF THE CONCRETE COLLAR. CONCRETE COLLAR SHALL BE 1/8" - 1/4" LOWER THAN ASPHALT.
- 3- ASPHALT SHALL BE CUT IN STRAIGHT VERTICAL LINES.
- 4- ADJUSTMENTS TO GRADE SHALL BE MADE WITH STANDARD RINGS OR EXTENTIONS OR AS APPROVED BY THE CITY REPRESENTATIVE.
- 5- ALL MANHOLES, VALVE BOXES AND OTHER SIMILAR ITEMS SHALL HAVE CONCRETE COLLAR AS REQUIRED UNLESS OTHERWISE APPROVED.
- 6- 9" THICK COLLARS SHALL BE REINFORCED.
- 7- MARK CONCRETE COLLAR ON WATER VALVE BOXES WITH ARROW INDICATING DIRECTION OF FLOW AND PIPE SIZE.

CITY OF TOQUERVILLE

REVISIONS		
DATE	DESCRIPTION	BY

**MANHOLES & VALVE BOXES
CONCRETE COLLAR**

STANDARD DWG. NO.	
171	1 OF 1
APPROVED:	
DATE:	BY: LBB

NOTES:

- 1- USE BICYCLE SAFE GRATE ONLY UNLESS OTHERWISE APPROVED. SEE STANDARD DRAWING.
- 2- BOXES WITH PIPE SIZE GREATER THAN 15" DIAMETER AND BOXES GREATER THAN 4' IN DEPTH REQUIRE ENGINEERED DESIGN.
- 3- GRATES & FRAMES SHALL BE PAINTED WITH ONE COAT PRIMER AND ONE COAT LIGHT GREY FINISH. COATING APPLIED PER SPECIFICATIONS.

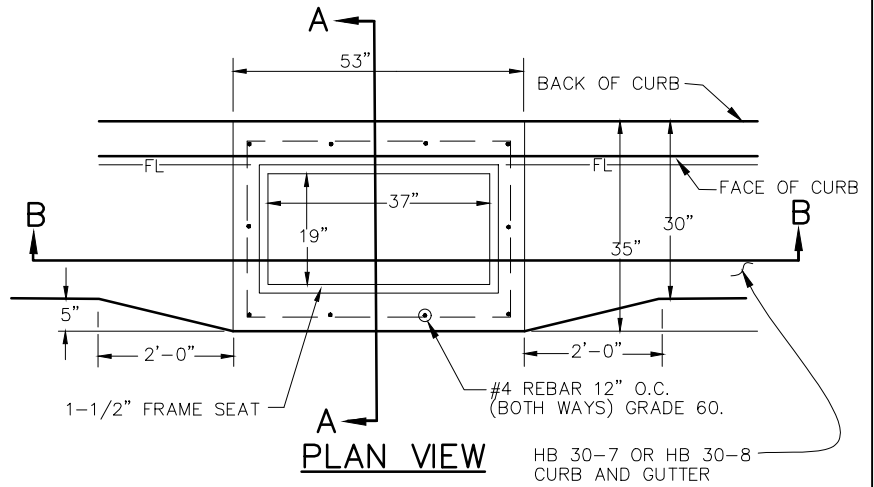

PLAN VIEW

HB 30-7 OR HB 30-8 CURB AND GUTTER

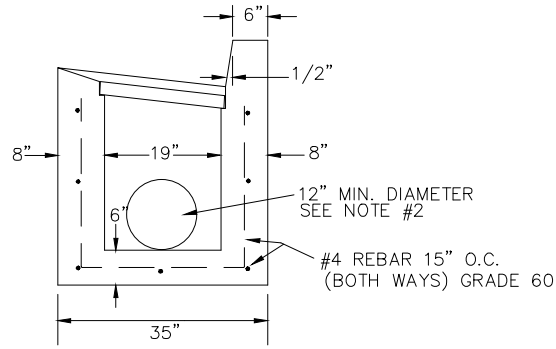

SECTION A-A

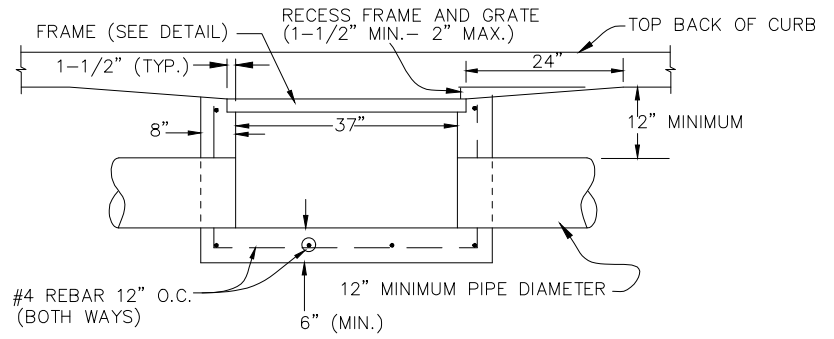

SECTION B-B

LONG DIMENSION OF BOX SHALL BE PARALLEL TO THE CURB & GUTTER.

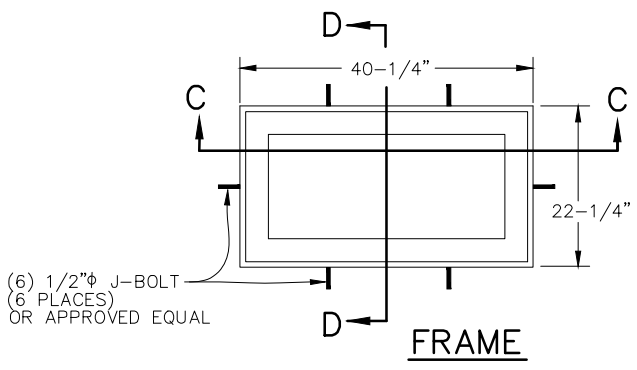

FRAME

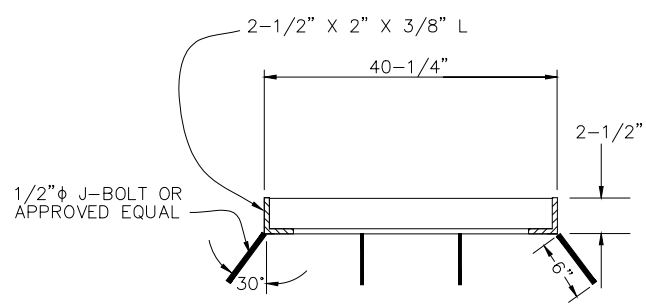

SECTION C-C

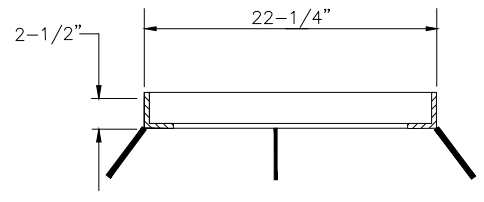

SECTION D-D

NO SCALE

CITY OF TOQUERVILLE

STANDARD CATCH BASIN BOX & FRAME

REVISIONS		
DATE	DESCRIPTION	BY

STANDARD DWG. NO.	
200	1 OF 1
APPROVED:	
DATE:	BY: LBB

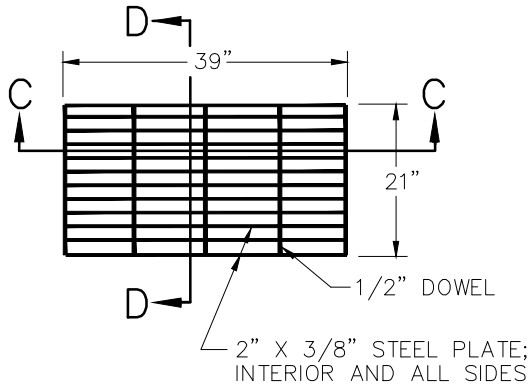

PLAN

NOTES:

- 1- STEEL SHALL BE COLD ROLLED FLAT STOCK.

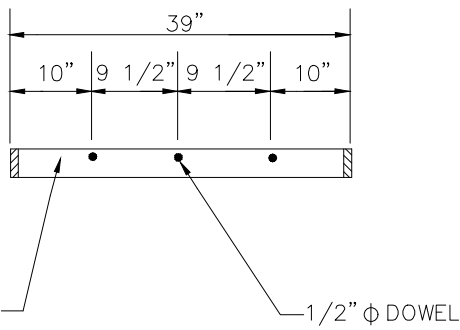

SECTION C-C

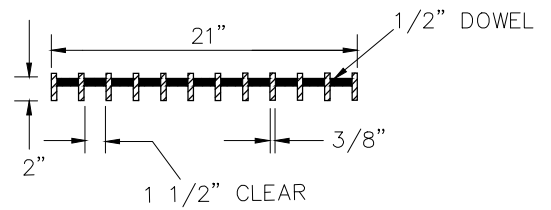

SECTION D-D

NO SCALE

CITY OF TOQUERVILLE

REVISIONS		
DATE	DESCRIPTION	BY

**CATCH BASIN GRATE
(NON-BICYCLE SAFE)**

STANDARD DWG. NO.	
201	1 OF 1
APPROVED:	
DATE:	BY: LBB

NOTES:

1. USE ONLY GRADE 60 STEEL
2. PAINT ALL SURFACES OF GRATE. APPLY ONE COAT OF PRIMER , AND ONE FINISH COAT, (LIGHT GREY COLOR) AS PER STANDARD CITY SPECIFICATIONS

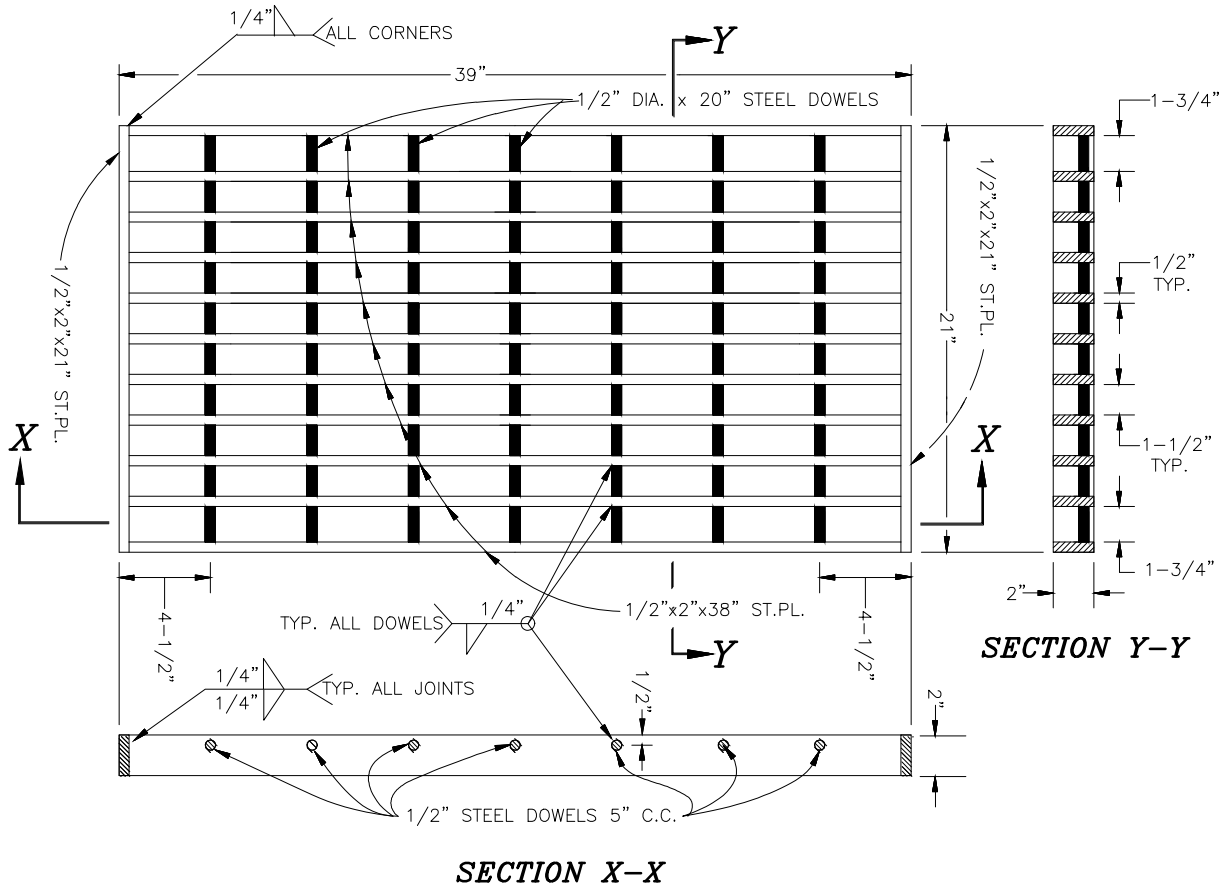

CITY OF TOQUERVILLE

REVISIONS		
DATE	DESCRIPTION	BY

STANDARD CATCH BASIN GRATE
(BICYCLE SAFE)

STANDARD DWG. NO.	
202	1 OF 1
APPROVED:	
DATE:	BY: HSP

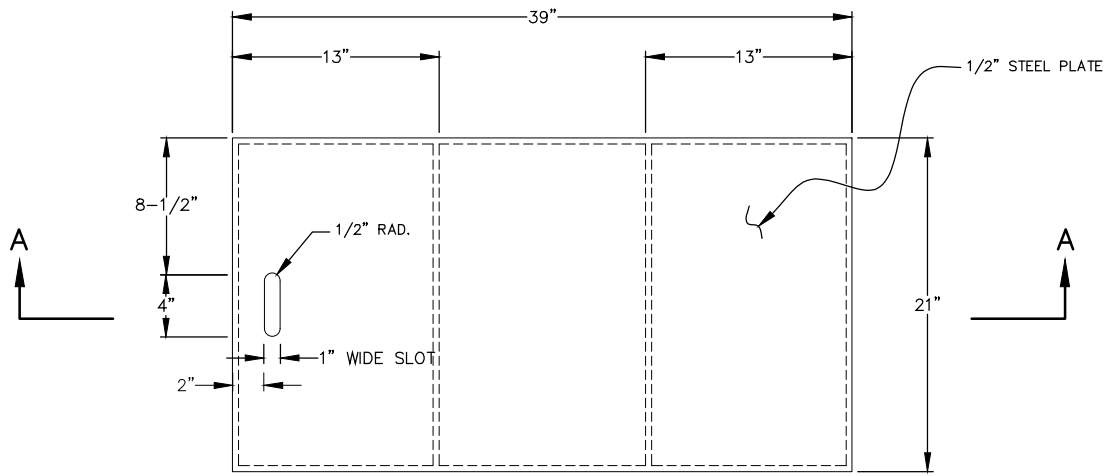

- NOTES:
- 1- FINISH SHALL BE ONE COAT PRIMER, ONE FINISH COAT, LIGHT GRAY ENAMEL.
 - 2- LID SHALL BE ALL WELDED CONSTRUCTION.
 - 3- FOR USE IN NON-TRAFFIC INSTALLATIONS.
 - 4- LID SHALL BE DIAMOND PLATE STEEL.

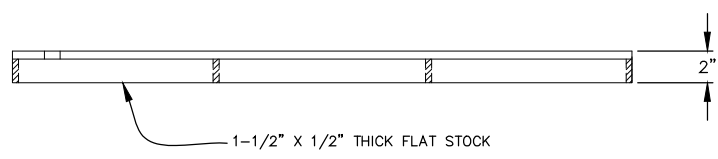

SECTION A-A

CITY OF TOQUERVILLE

REVISIONS		
DATE	DESCRIPTION	BY

39" SOLID LID DETAILS

STANDARD DWG. NO.	
203	1 OF 2
APPROVED:	
DATE:	BY: LBB

NOTE:
STEEL LID TO BE FLUSH
WITH CONCRETE SIDEWALK.

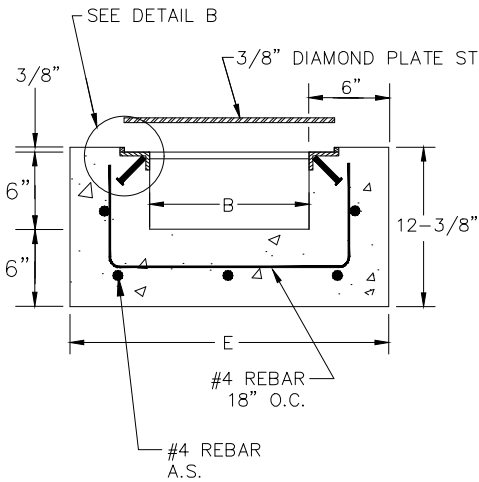

SECTION B-B

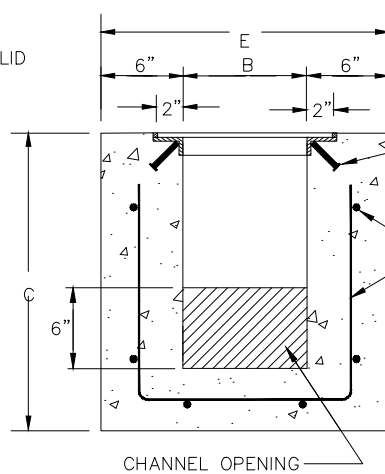

SECTION C-C

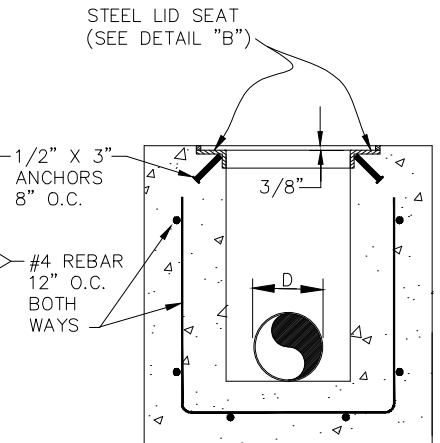

SECTION D-D

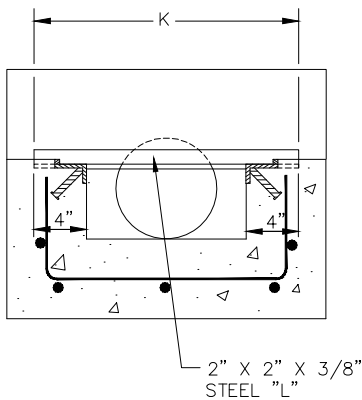

SECTION E-E

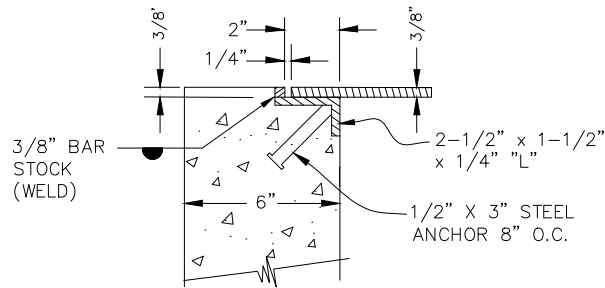

DETAIL B

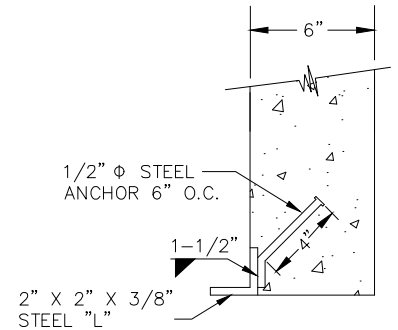

DETAIL C

MARK	DIMENSION (INCHES)				COMMENTS
	B	C	D	E	
B	10	15	20	30*	INSIDE WIDTH
C	20	22	24	27	CLEANOUT BOX HEIGHT
D	≤ 8	10	12	15	INLET PIPE
E	22	27	32	42	BOX WIDTH
K	18	23	28	38	STEEL END SUPPORT

DIMENSION TABLE

*REQUIRES ENGINEERED DESIGN FOR LID & BOX.

NOTES:

- 1- ALL REBAR SHALL HAVE 2" MIN. CLEAR.
- 2- STEEL LID SHALL BE FLUSH WITH CONCRETE.
- 3- BOX DIMENSIONS BASED UPON INLET PIPE SIZE "D".
- 4- ALL STEEL SHALL BE GRADE 60.
- 5- LID FOR CLEANOUT BOX SHALL HAVE 1-4 INCH X 1" SLOT FOR LIFTING. LID MAY BE SMOOTH OR DIAMOND PLATE STEEL.
- 6- SIDEWALK LID SHALL BE DIAMOND PLATE STEEL.
- 7- STANDARD REBAR SHALL NOT BE USED FOR STEEL ANCHORS.
- 8- ALL EXTERIOR EDGES OF CLEANOUT BOX TO HAVE 3/4" TO 1" CHAMFER (NOT SHOWN IN DETAILS FOR CLARITY).
- 9- STEEL LIDS AND SEAT TO BE PAINTED GREY IN ACCORDANCE WITH CITY STANDARDS.

CITY OF TOQUERVILLE

REVISIONS		
DATE	DESCRIPTION	BY

SIDEWALK DRAINAGE STRUCTURE

STANDARD DWG. NO.	
204	2 OF 2
APPROVED:	
DATE:	BY: LBB

NOTE:
FOR NOTES SEE SHEET 2 OF 2

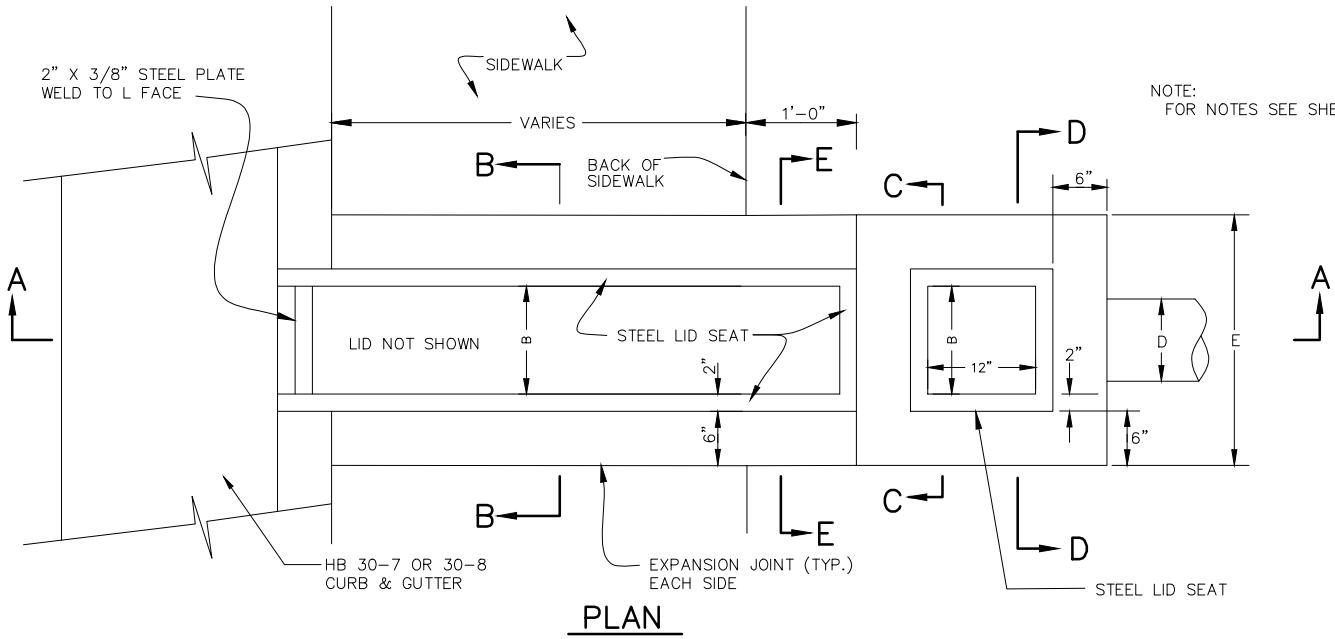

PLAN

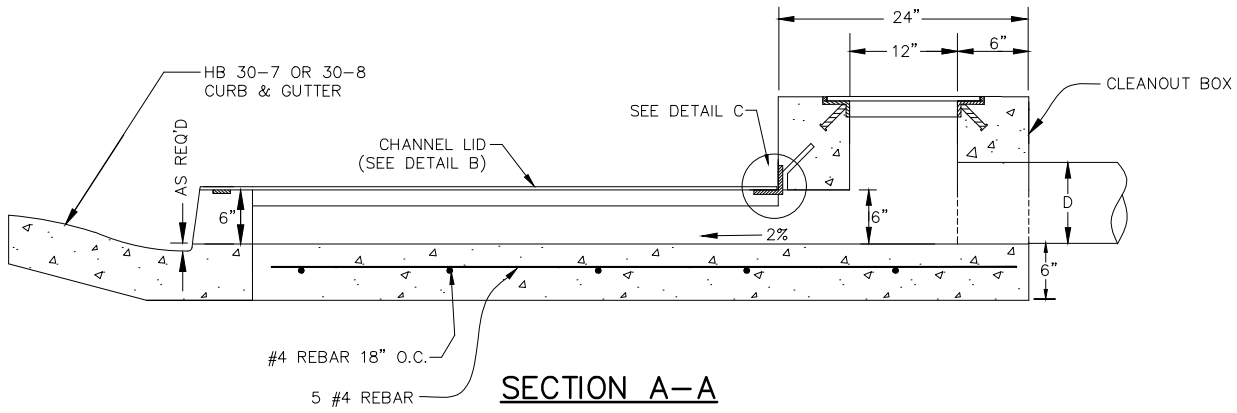

SECTION A-A

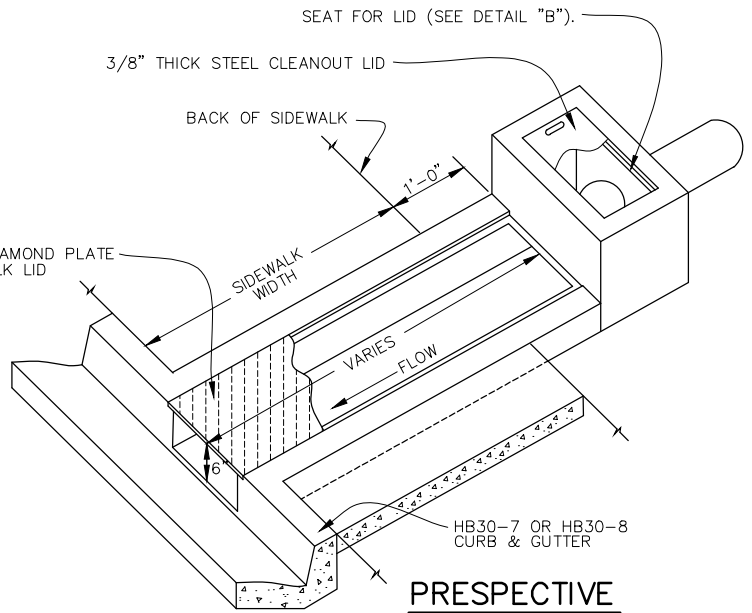

PRESPECTIVE

MARK	DIMENSION (INCHES)				COMMENTS
	B	C	D	E	
B	10	15	20	30*	INSIDE WIDTH
C	20	22	24	27	CLEANOUT BOX HEIGHT
D	≤8	10	12	15	INLET PIPE
E	22	27	32	42	BOX WIDTH
K	18	23	28	38	STEEL END SUPPORT

DIMENSION TABLE

*REQUIRES ENGINEERED DESIGN FOR LID & BOX.

CITY OF TOQUERVILLE

STANDARD DWG. NO.
204 1 OF 2

SIDEWALK DRAINAGE STRUCTURE

APPROVED:
DATE: BY: LBB

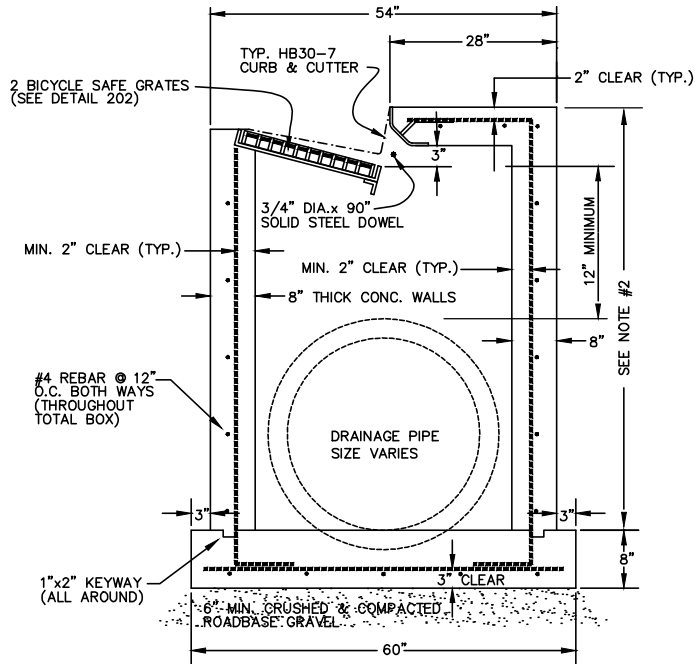
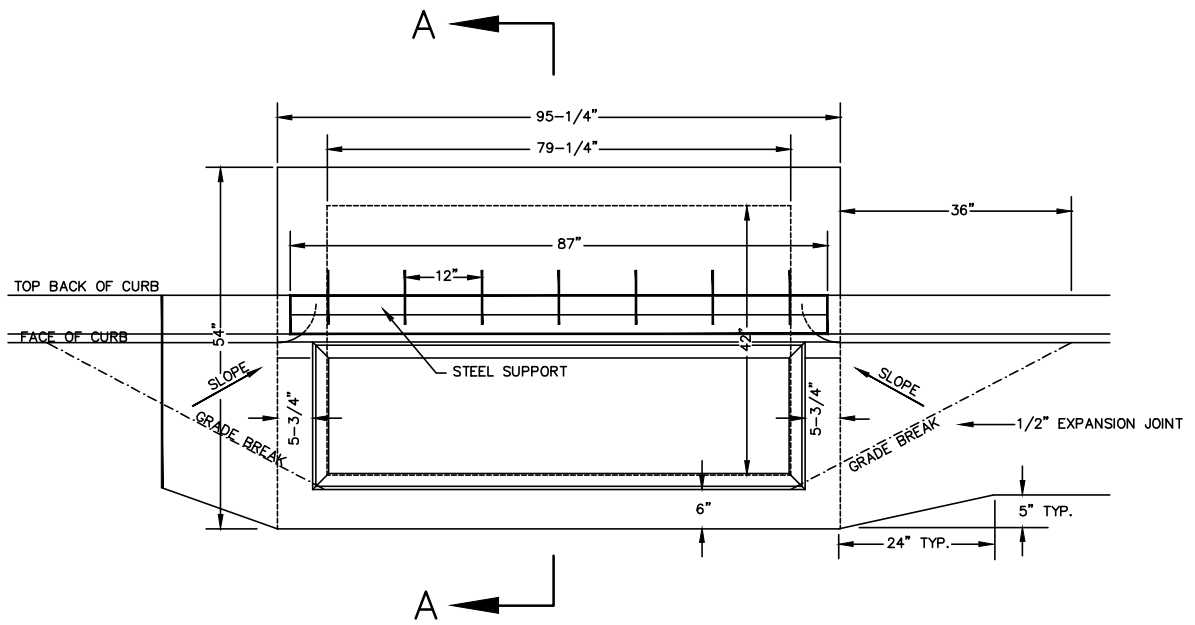

- NOTES:
- 1- USE BICYCLE SAFE GRATES ONLY.
 - 2- FOR PIPE SIZE GREATER THAN 42" DIAMETER AND 60" DEPTH ENGINEERED DESIGN REQUIRED.

SECTION A-A

CITY OF TOQUERVILLE

REVISIONS		
DATE	DESCRIPTION	BY

CURB INLET DOUBLE CATCH BASIN BOX

STANDARD DWG. NO.	
205	1 OF 2
APPROVED:	
DATE:	BY: LBB

PLAN VIEW

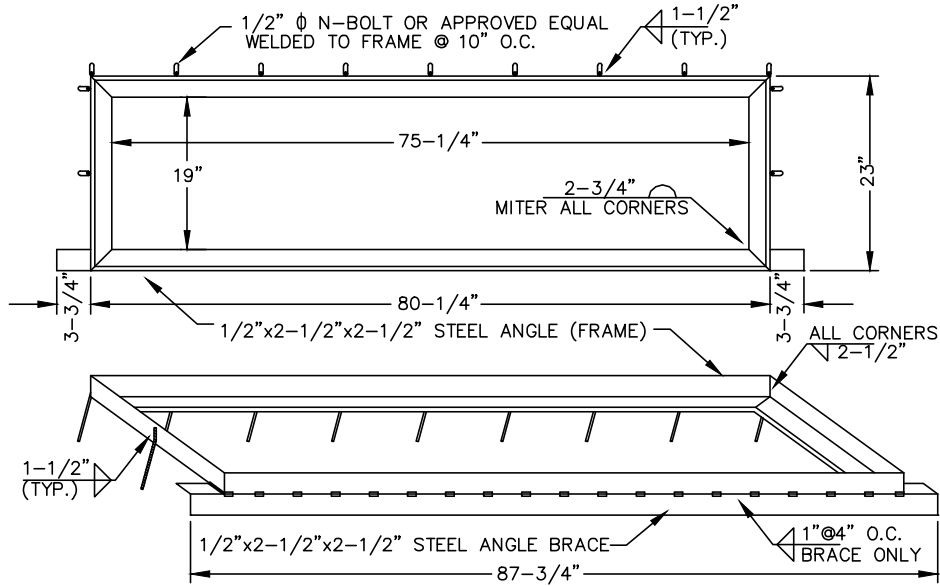

FRAME & SUPPORT BRACE

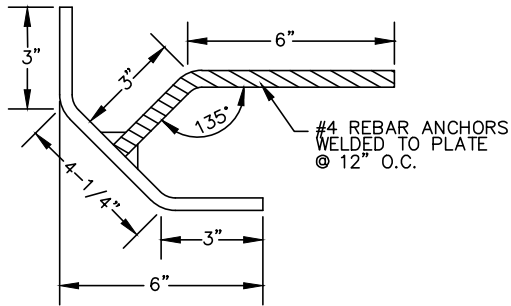

STEEL SUPPORT

NOTES:

1. FRAME SHALL BE PAINTED WITH ONE COAT PRIMER AND ONE COAT LIGHT GREY FINISH.

CITY OF TOQUERVILLE

REVISIONS		
DATE	DESCRIPTION	BY

CURB INLET DOUBLE CATCH BASIN FRAME

STANDARD DWG. NO.	
205	2 OF 2
APPROVED:	
DATE:	BY: LBB

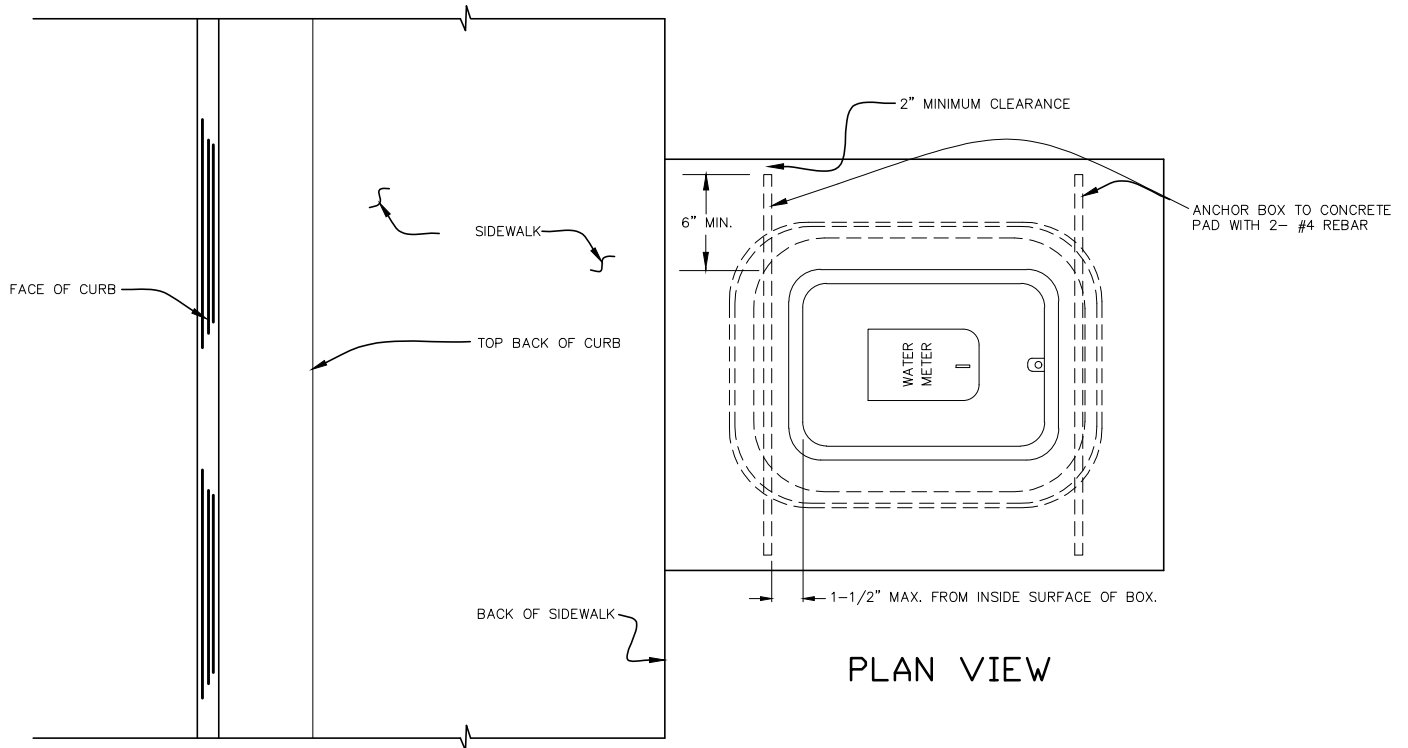

PLAN VIEW

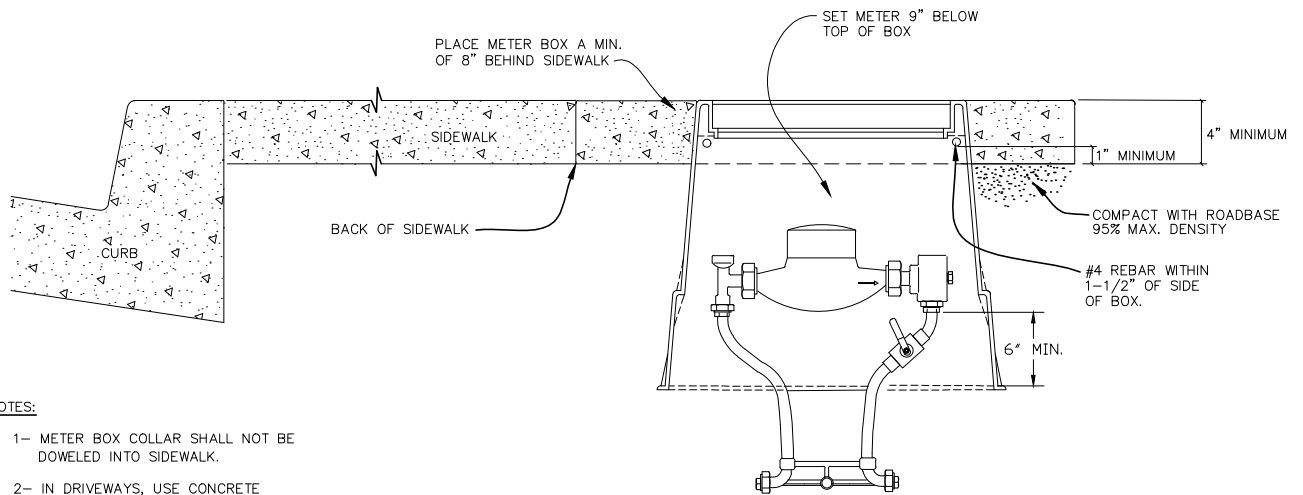

SECTION

NOTES:

- 1- METER BOX COLLAR SHALL NOT BE DOWELED INTO SIDEWALK.
- 2- IN DRIVEWAYS, USE CONCRETE BOX WITH CAST IRON LID.

CITY OF TOQUERVILLE

WATER METER BOX
DETAILS

STANDARD DWG. NO.

300 1 OF 1

APPROVED:

DATE: BY: LBB

REVISIONS		
DATE	DESCRIPTION	BY

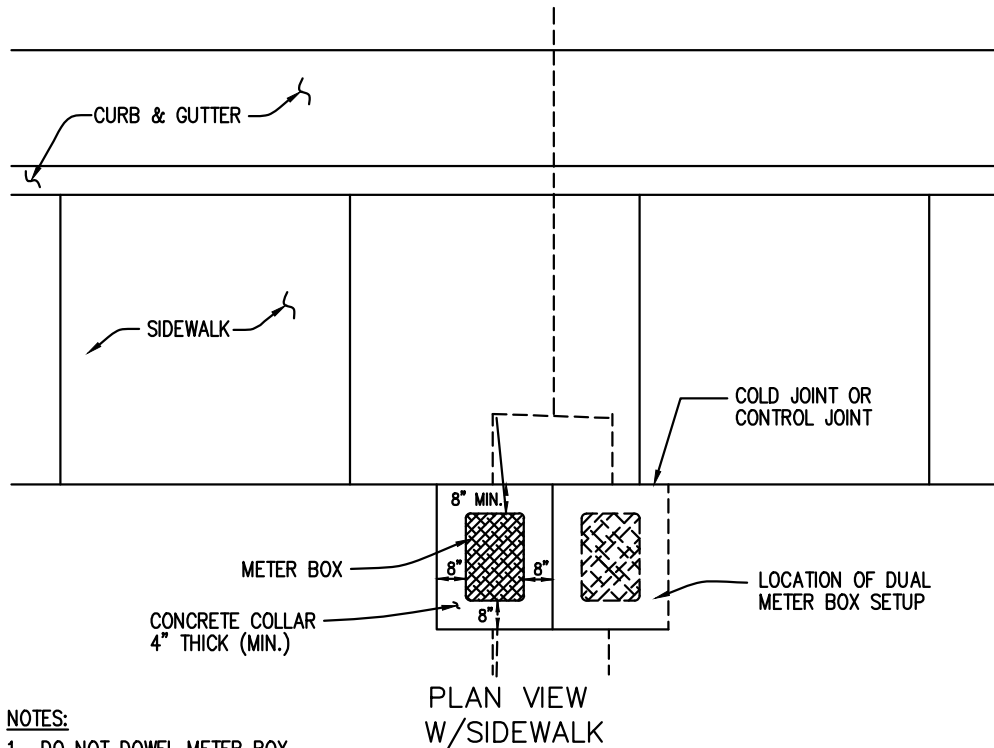

NOTES:
1- DO NOT DOWEL METER BOX
COLLAR INTO SIDEWALK.

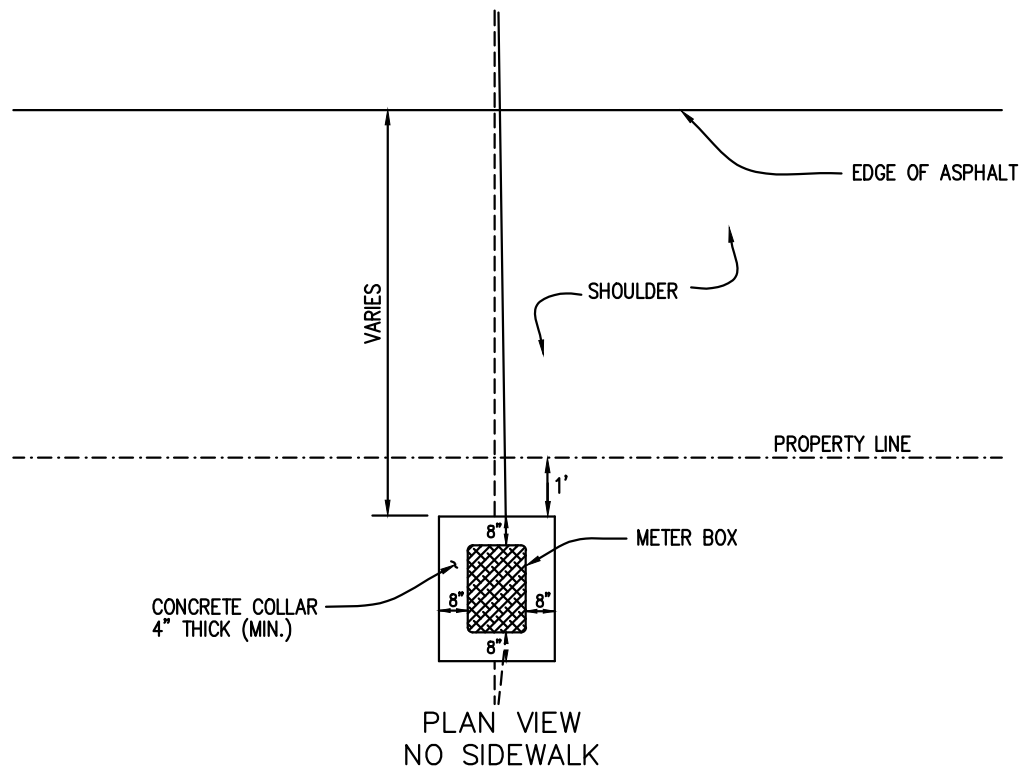

CITY OF TOQUERVILLE

REVISIONS		
DATE	DESCRIPTION	BY

WATER METER BOX LOCATION
DETAILS

STANDARD DWG. NO.	
301	1 OF 1
APPROVED:	
DATE:	BY: LBB

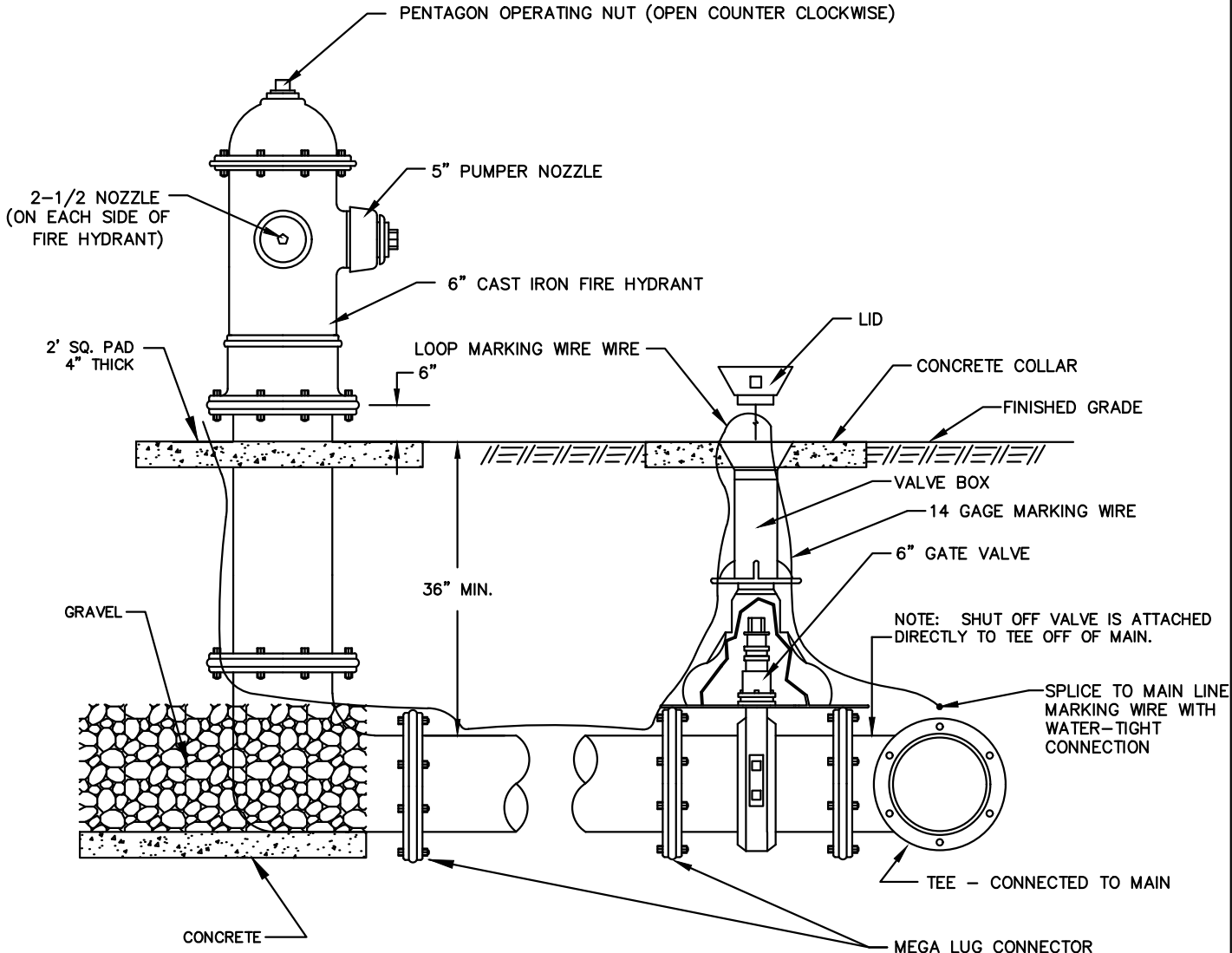

NOTES:

1- IN GENERAL, HYDRANTS SHALL BE PLACED A MINIMUM OF 1' BEHIND SIDEWALK. WHERE A PLANTER STRIP IS USED, HYDRANT MAY BE PLACED IN CENTER PROVIDED WIDTH OF PLANTER IS 4' OR GREATER.

CITY OF TOQUERVILLE

REVISIONS		
DATE	DESCRIPTION	BY

STANDARD FIRE HYDRANT
DETAILS

STANDARD DWG. NO.	
302	1 OF 1
APPROVED:	
DATE:	BY: LBB

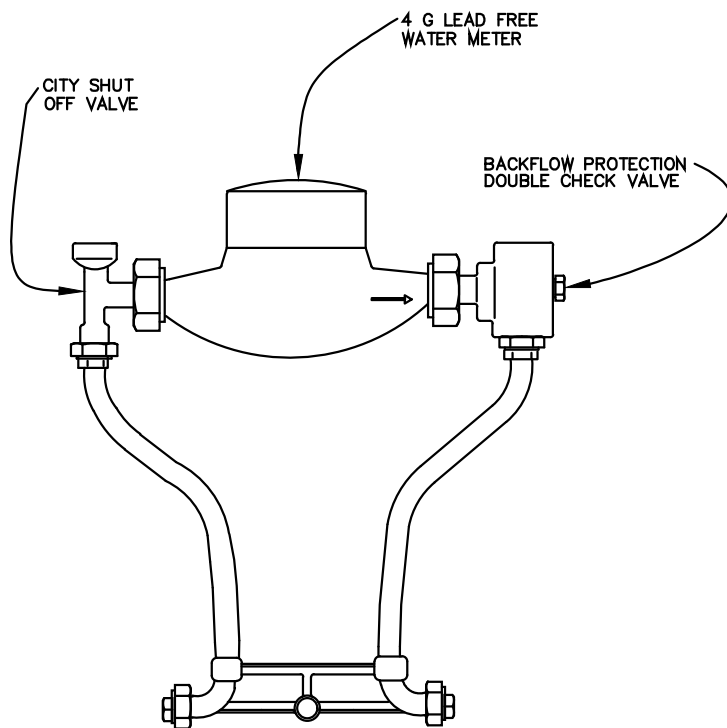

CITY OF TOQUERVILLE

REVISIONS		
DATE	DESCRIPTION	BY

WATER METER SETTER
DETAILS

STANDARD DWG. NO.	
303	1 OF 1
APPROVED:	
DATE:	BY: LBB

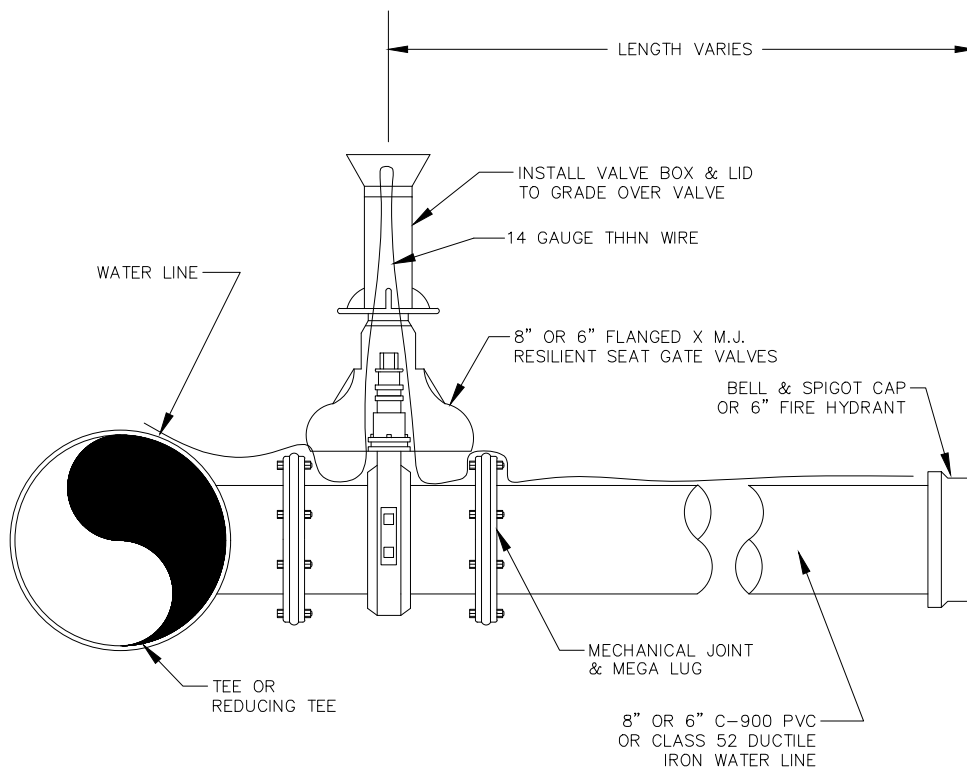

CITY OF TOQUERVILLE

REVISIONS		
DATE	DESCRIPTION	BY

**8" OR 6" WATER LATERAL
(CONNECTION TO EXISTING LINE)**

STANDARD DWG. NO.	
304	1 OF 1
APPROVED:	
DATE:	BY: LBB

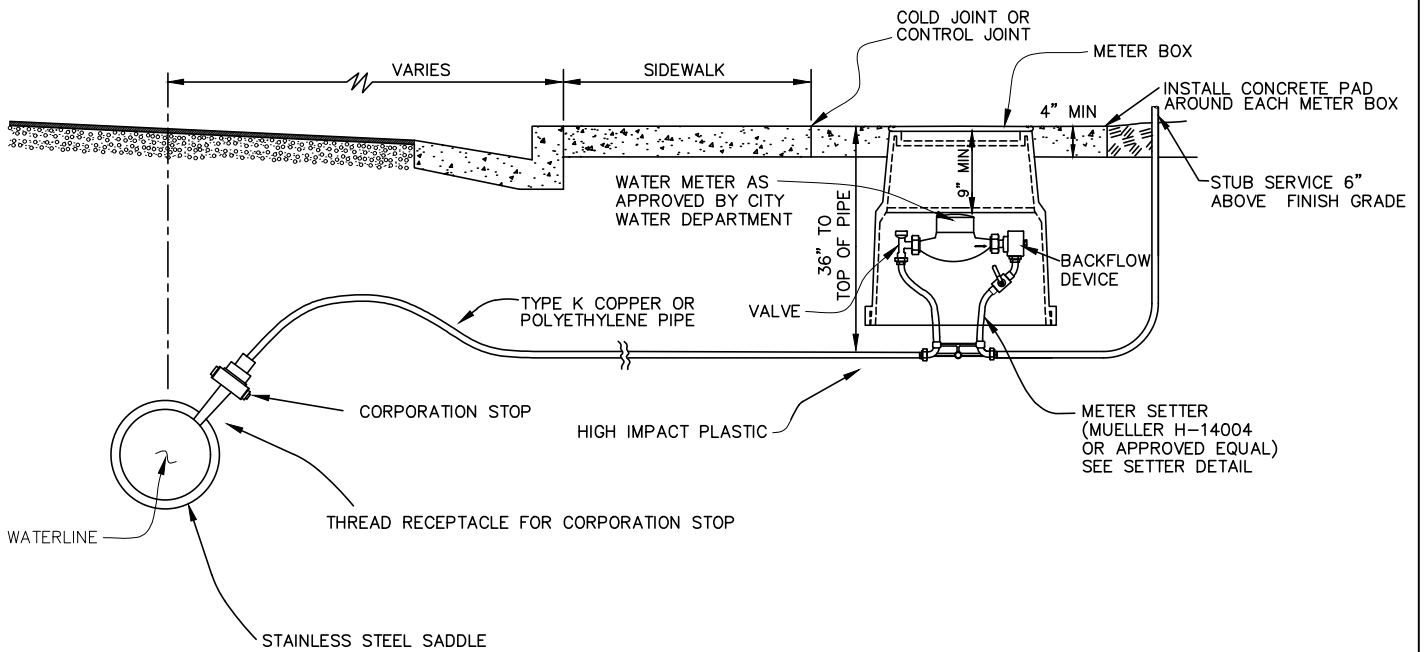

NOTES:
 1- ALL TRENCH EXCAVATION AND COMPACTION SHALL BE IN ACCORDANCE WITH STANDARD SPECIFICATIONS.

CITY OF TOQUERVILLE

**3/4" WATER SERVICE CONNECTION
& METER**

STANDARD DWG. NO.

305 1 OF 1

APPROVED:

DATE: BY: LBB

REVISIONS		
DATE	DESCRIPTION	BY

THRUST BLOCK BEARING AREA IN SQUARE FEET								
PIPE SIZE	CONDITION							
	I	II	III	IV	V	VI	VII	VII
4"	2.6	3.3	2.6	1.3	1.3	2.0	3.3	2.6
6"	4.6	6.5	3.9	2.0	2.6	3.3	6.5	4.6
8"	7.8	11.0	5.9	3.3	3.9	5.9	11.0	7.8
10"	12.4	17.5	9.8	5.2	6.5	9.1	17.5	12.4
12"	17.5	24.8	13.6	7.8	9.1	12.3	24.8	17.5
14"	24.0	33.8	18.2	9.7	12.3	16.9	33.8	24.0
16"	31.1	44.0	23.8	12.7	15.5	23.2	44.0	31.1

1. CALCULATED ON 225 LB. TEST PRESSURE & ALLOWABLE BEARING PRESSURE OF 2000 LBS. PER SQUARE FOOT.
2. IN POOR SOILS SPECIAL DESIGN IS REQUIRED.
3. CONCRETE SHALL BE CLASS "C" OR BETTER.
4. ALL THRUST BLOCK BEARING FACES SHALL BE POURED AGAINST UNDISTURBED SOIL OR APPROVED COMPACTED BACKFILL.
5. PRIOR APPROVAL FROM THE WATER DEPARTMENT REQUIRED FOR USE OF CONCRETE THRUST BLOCKS.

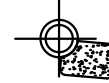

TYPICAL SECTION THRU THRUST BLOCKS

VALVE ANCHOR REQUIRED FOR VALVES 12" OR LARGER

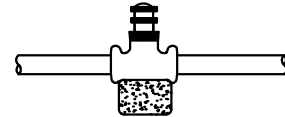

THRUST BLOCKING

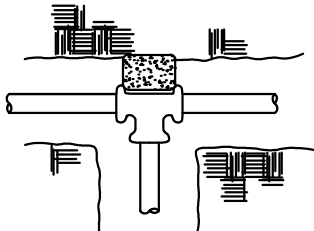

CONDITION I

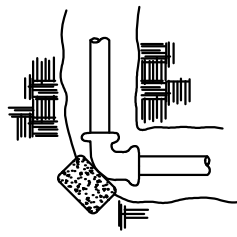

CONDITION II

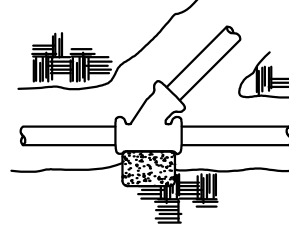

CONDITION III

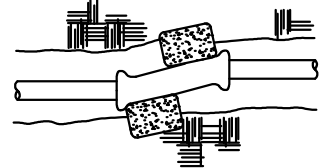

CONDITION IV

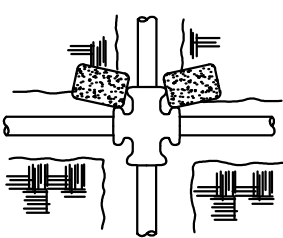

CONDITION V

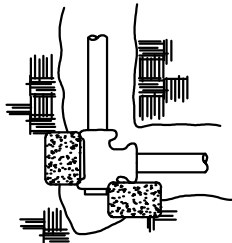

CONDITION VI

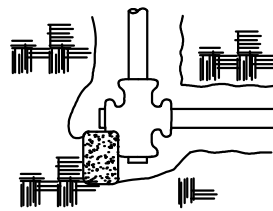

CONDITION VII

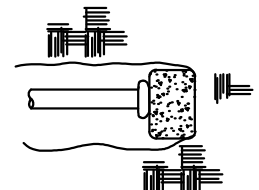

CONDITION VIII

CITY OF TOQUERVILLE

REVISIONS		
DATE	DESCRIPTION	BY

TEMPORARY WATER LINE THRUST BLOCK FOR TESTING
DETAILS

STANDARD DWG. NO.	
306	1 OF 1
APPROVED:	
DATE:	BY: LBB

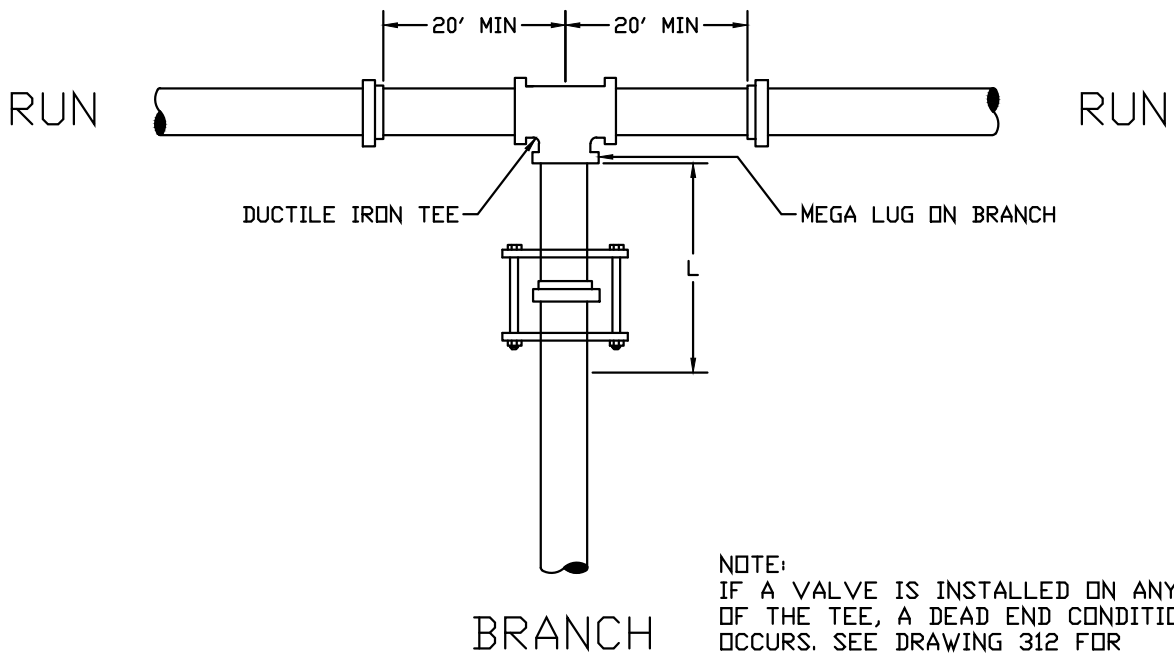

NOTE:
IF A VALVE IS INSTALLED ON ANY SIDE OF THE TEE, A DEAD END CONDITION OCCURS. SEE DRAWING 312 FOR RESTRAINING.

		RUN SIZE DIAMETER								
		6	8	10	12	14	16	18	20	24
BRANCH SIZE DIAMETER	4	*	*	*	*	*	*	*	*	*
	6	*	*	*	*	*	*	*	*	*
	6	X	*	*	*	*	*	*	*	*
	10	X	X	*	*	*	*	*	*	*
	12	X	X	X	15	*	*	*	*	*
	14	X	X	X	X	31	13	*	*	*
	16	X	X	X	X	X	48	31	14	*
	18	X	X	X	X	X	X	64	48	16
	20	X	X	X	X	X	X	X	80	48
	24	X	X	X	X	X	X	X	X	110

* - FOR THIS CONDITION NEED ONLY RESTRAIN THE BRANCH OUTLET OF THE TEE.

RESTRAINED LENGTHS, "L" (IN FEET)

1. RESTRAIN THE TWO MECHANICAL JOINTS ON THE RUN SIDES OF THE TEE. THERE SHOULD BE A FULL 20' LENGTH OF PIPE INSTALLED ON EACH SIDE OF THE RUN.
2. ALL JOINTS WITHIN THE LENGTH "L" ON THE BRANCH MUST BE RESTRAINED. USE RETAINER GLAND AT MECHANICAL JOINTS AND HARNESS ON PUSH-ON PIPE PER CITY SPECIFICATION.
3. FOR TEST PRESSURES AND LAYING CONDITIONS SEE SECTION ON GENERAL NOTES FOR USE OF RESTRAINED JOINT LENGTHS.

CITY OF TOQUERVILLE

REVISIONS		
DATE	DESCRIPTION	BY

STANDARD TEE PVC
RESTRAINING SYSTEM DETAIL

STANDARD DWG. NO.	
307	1 OF 1
APPROVED:	
DATE:	BY: LBB

MEGA LUG ON JOINT

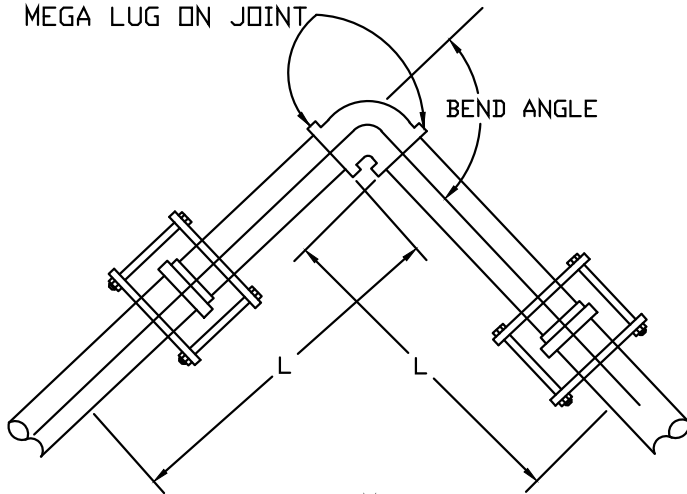

HORIZONTAL BEND

1. ALL JOINTS WITHIN LENGTH "L" MUST BE RESTRAINED. USE RETAINER GLAND AT MECHANICAL JOINTS AND HARNESS WITH PUSH-ON PIPE PER CITY SPECIFICATION.
2. FOR TEST PRESSURES AND LAYING CONDITIONS SEE SECTION ON GENERAL NOTES FOR USE OF RESTRAINED JOINT LENGTHS.

		SIZE DIAMETER								
		4	6	8	10	12	14	16	18	20
BEND ANGLE	11.25	2	3	3	4	5	5	6	6	7
	22.5	4	5	6	8	9	10	11	12	13
	45	7	10	13	15	18	20	22	25	27
	90	17	24	30	36	42	48	53	58	63

RESTRAINED LENGTHS, "L" (IN FEET)

MEGA LUG ON JOINT

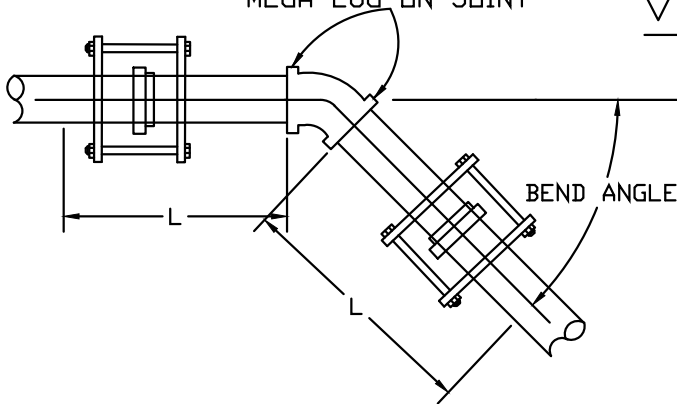

VERTICAL DOWN BEND

1. ALL JOINTS WITHIN LENGTH "L" MUST BE RESTRAINED. USE RETAINER GLAND AT MECHANICAL JOINTS AND HARNESS WITH PUSH-ON PIPE PER CITY SPECIFICATION.
2. FOR TEST PRESSURES AND LAYING CONDITIONS SEE SECTION ON GENERAL NOTES FOR USE OF RESTRAINED JOINT LENGTHS.

		SIZE DIAMETER								
		4	6	8	10	12	14	16	18	20
BEND ANGLE	11.25	5	7	10	11	13	15	17	19	21
	22.5	10	15	19	23	27	30	34	38	41
	45	21	30	39	46	55	62	70	78	85

RESTRAINED LENGTHS, "L" (IN FEET)

CITY OF TOQUERVILLE

REVISIONS		
DATE	DESCRIPTION	BY

STANDARD BENDS FOR PVC
RESTRAINING SYSTEM DETAIL

STANDARD DWG. NO.	
308	1 OF 1
APPROVED:	
DATE:	BY: LBB

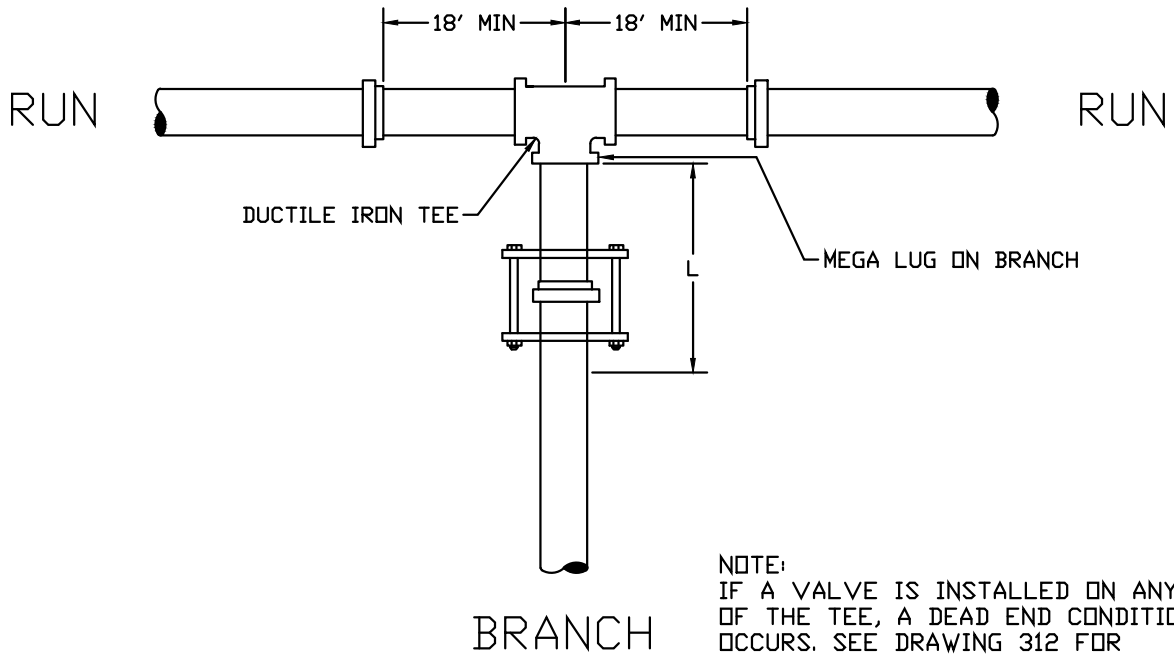

RUN SIZE DIAMETER

	6	8	10	12	14	16	18	20	24	
BRANCH SIZE DIAMETER	4	*	*	*	*	*	*	*	*	
	6	*	*	*	*	*	*	*	*	
	8	X	*	*	*	*	*	*	*	
	10	X	X	*	*	*	*	*	*	
	12	X	X	X	24	*	*	*	*	
	14	X	X	X	X	50	21	*	*	
	16	X	X	X	X	X	77	49	21	
	18	X	X	X	X	X	X	102	76	25
	20	X	X	X	X	X	X	X	127	77
	24	X	X	X	X	X	X	X	X	175

* - FOR THIS CONDITION NEED ONLY RESTRAIN THE BRANCH OUTLET OF THE TEE.

RESTRAINED LENGTHS, "L" (IN FEET)

1. RESTRAIN THE TWO MECHANICAL JOINTS ON THE RUN SIDES OF THE TEE. THERE SHOULD BE A FULL 18' LENGTH OF PIPE INSTALLED ON EACH SIDE OF THE RUN.
2. ALL JOINTS WITHIN THE LENGTH "L" ON THE BRANCH MUST BE RESTRAINED. USE RETAINER GLAND AT MECHANICAL JOINTS AND HARNESS ON PUSH-ON PIPE PER CITY SPECIFICATION.
3. FOR TEST PRESSURES AND LAYING CONDITIONS SEE SECTION ON GENERAL NOTES FOR USE OF RESTRAINED JOINT LENGTHS.

CITY OF TOQUERVILLE

REVISIONS		
DATE	DESCRIPTION	BY

STANDARD TEE DUCTILE IRON
RESTRAINING SYSTEM DETAIL

STANDARD DWG. NO.	
309	1 OF 1
APPROVED:	
DATE:	BY: LBB

MEGA LUG ON JOINT

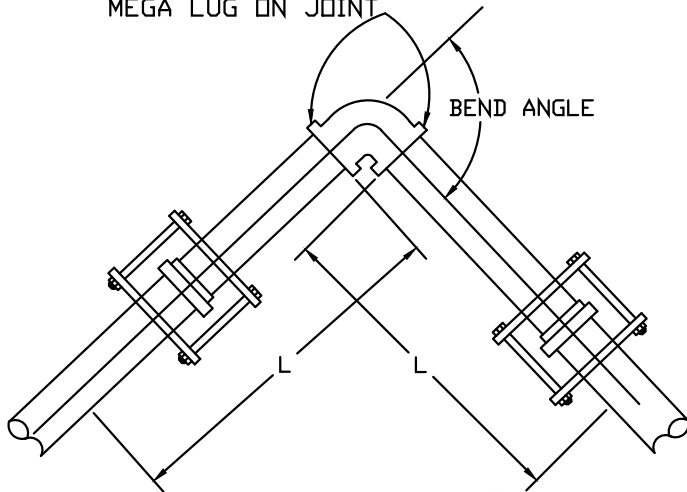

HORIZONTAL BEND

1. ALL JOINTS WITHIN LENGTH "L" MUST BE RESTRAINED. USE RETAINER GLAND AT MECHANICAL JOINTS AND HARNESS WITH PUSH-ON PIPE PER CITY SPECIFICATION.
2. FOR TEST PRESSURES AND LAYING CONDITIONS SEE SECTION ON GENERAL NOTES FOR USE OF RESTRAINED JOINT LENGTHS.

		SIZE DIAMETER							
		4	6	8	10	12	14	16	20
BEND ANGLE	11.25	2	2	3	3	4	4	5	6
	22.5	3	4	6	6	8	8	9	11
	45	4	9	11	13	15	15	19	23
	90	16	20	26	31	36	40	45	54

RESTRAINED LENGTHS, "L" (IN FEET)

MEGA LUG ON JOINT

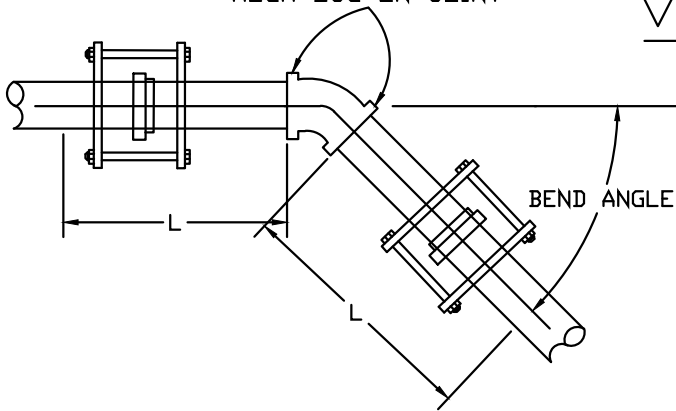

VERTICAL DOWN BEND

1. ALL JOINTS WITHIN LENGTH "L" MUST BE RESTRAINED. USE RETAINER GLAND AT MECHANICAL JOINTS AND HARNESS WITH PUSH-ON PIPE PER CITY SPECIFICATION.
2. FOR TEST PRESSURES AND LAYING CONDITIONS SEE SECTION ON GENERAL NOTES FOR USE OF RESTRAINED JOINT LENGTHS.

		SIZE DIAMETER							
		4	6	8	10	12	14	16	20
BEND ANGLE	11.25	4	5	6	7	9	10	11	13
	22.5	7	9	12	15	17	19	22	26
	45	14	19	25	30	35	40	45	54

RESTRAINED LENGTHS, "L" (IN FEET)

CITY OF TOQUERVILLE

REVISIONS		
DATE	DESCRIPTION	BY

STANDARD BENDS FOR DUCTILE IRON
RESTRAINING SYSTEM DETAIL

STANDARD DWG. NO.	
310	1 OF 1
APPROVED:	
DATE:	BY: LBB

STANDARD DEAD END FOR DUCTILE IRON

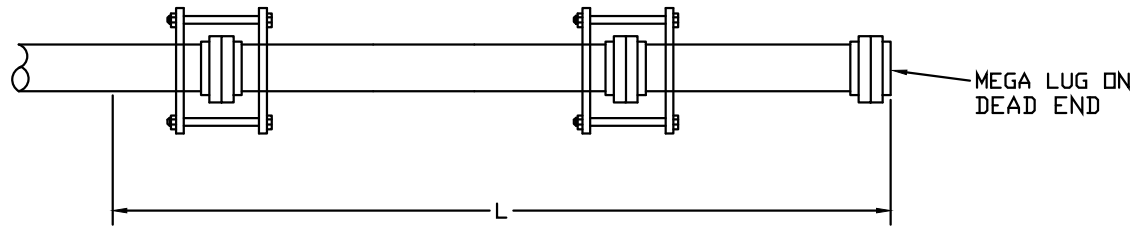

1. ALL JOINTS WITHIN LENGTH "L" MUST BE RESTRAINED. USE RETAINER GLAND AT MECHANICAL JOINTS AND HARNESS WITH PUSH-ON PIPE PER CITY SPECIFICATION.
2. FOR TEST PRESSURES AND LAYING CONDITIONS SEE SECTION ON GENERAL NOTES FOR USE OF RESTRAINED JOINT LENGTHS.

PIPE SIZE IN INCHES								
4	6	8	10	12	14	16	18	20
78	109	143	171	201	229	257	285	312

RESTRAINED LENGTHS, "L" (IN FEET)

RESTRAINED JOINT LENGTHS USAGE GENERAL NOTES

RESTRAINED LENGTH CALCULATIONS ARE BASED ON THE FOLLOWING DESIGN TYPICALLY USED WITH BACKFILL IN ST. GEORGE.

1. THREE (3) FEET MINIMUM DEPTH OF COVER.
2. A SAFETY FACTOR OF 1.5
3. SOIL TYPE SANDY CLAY
4. TYPE 5 TRENCH COMPACTION FROM FOUR (4) INCHES MINIMUM UNDER THE PIPE TO THE CENTER LINE OF THE PIPE, AND COMPACTED GRANULAR OR SELECTED MATERIAL FROM THE CENTER LINE OF THE PIPE TO THE TOP OF THE PIPE (90 PERCENT STANDARD PROCTOR DENSITY, AASHTO T-99).
5. 200 PSI TEST PRESSURES FOR FOUR (4) THROUGH SIXTEEN (16) INCH SIZE PIPES.

IF ACTUAL CONDITIONS DIFFER FROM THOSE LISTED ABOVE OR THE REQUIRED RESTRAINED LENGTH CANNOT BE MET, THE RESTRAINED JOINT LENGTH SHALL BE DETERMINED BY THE WATER AND POWER ENGINEER.

CITY OF TOQUERVILLE

REVISIONS			IN LINE VALVE/DEAD END FOR DUCTILE IRON DETAIL	STANDARD DWG. NO.	
DATE	DESCRIPTION	BY		311	1 OF 1
				APPROVED:	
				DATE:	BY: LBB

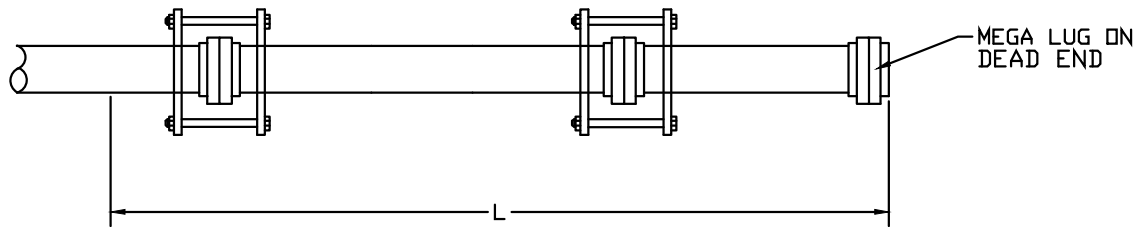

1. ALL JOINTS WITHIN LENGTH "L" MUST BE RESTRAINED. USE RETAINER GLAND AT MECHANICAL JOINTS AND HARNESS WITH PUSH-ON PIPE PER CITY SPECIFICATION.
2. FOR TEST PRESSURES AND LAYING CONDITIONS SEE SECTION ON GENERAL NOTES FOR USE OF RESTRAINED JOINT LENGTHS.

PIPE SIZE IN INCHES

4	6	8	10	12	14	16	18	20
51	71	93	111	131	150	169	187	204

RESTRAINED LENGTHS, "L" (IN FEET)

RESTRAINED JOINT LENGTHS USAGE GENERAL NOTES

RESTRAINED LENGTH CALCULATIONS ARE BASED ON THE FOLLOWING DESIGN TYPICALLY USED WITH BACKFILL IN ST. GEORGE.

1. THREE (3) FEET MINIMUM DEPTH OF COVER.
2. A SAFTEY FACTOR OF 1.5
3. SOIL TYPE SANDY CLAY
4. TYPE 5 TRENCH COMPACTION FROM FOUR (4) INCHES MINIMUM UNDER THE PIPE TO THE CENTER LINE OF THE PIPE, AND COMPACTED GRANULAR OR SELECTED MATERIAL FROM THE CENTER LINE OF THE PIPE TO THE TOP OF THE PIPE (90 PERCENT STANDARD PROCTOR DENSITY, AASHTO T-99).
5. 200 PSI TEST PRESSURES FOR FOUR (4) THROUGH SIXTEEN (16) INCH SIZE PIPES.

IF ACTUAL CONDITIONS DIFFER FROM THOSE LISTED ABOVE OR THE REQUIRED RESTRAINED LENGTH CANNOT BE MET, THE RESTRAINED JOINT LENGTH SHALL BE DETERMINED BY THE WATER AND POWER ENGINEER.

CITY OF TOQUERVILLE

REVISIONS			IN LINE VALVE/DEAD END FOR PVC PIPE DETAIL	STANDARD DWG. NO.	
DATE	DESCRIPTION	BY		312	1 OF 1
				APPROVED:	
				DATE:	BY: LBB

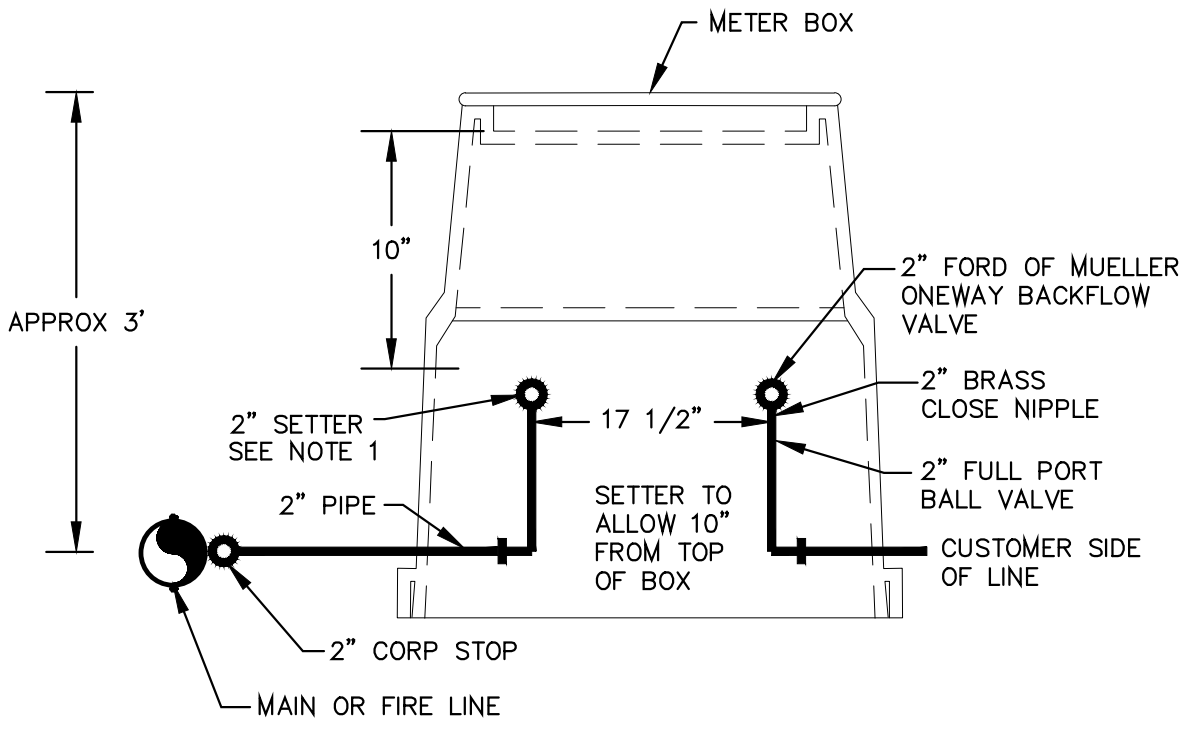

NOTES:

1- A 2" SOLID COPPER SETTER WITH A 2" BRASS FULL PORT BALL VALVE SHALL BE USED.

CITY OF TOQUERVILLE

REVISIONS		
DATE	DESCRIPTION	BY
2/02	EDIT SETTER	LBB

2" METER MECHANICAL PIPING
DETAIL

STANDARD DWG. NO.	
313	1 OF 1
APPROVED:	
DATE:	BY: LBB

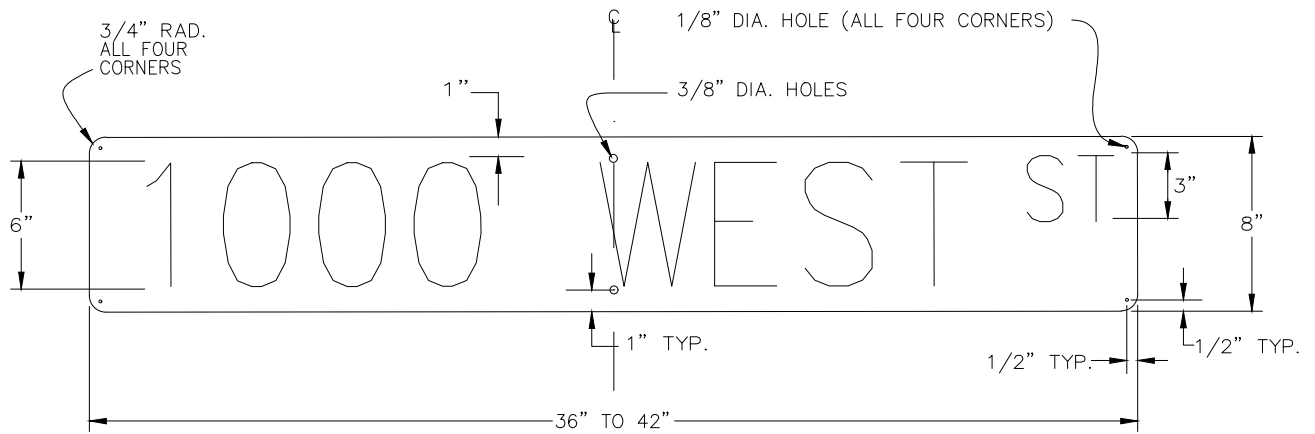
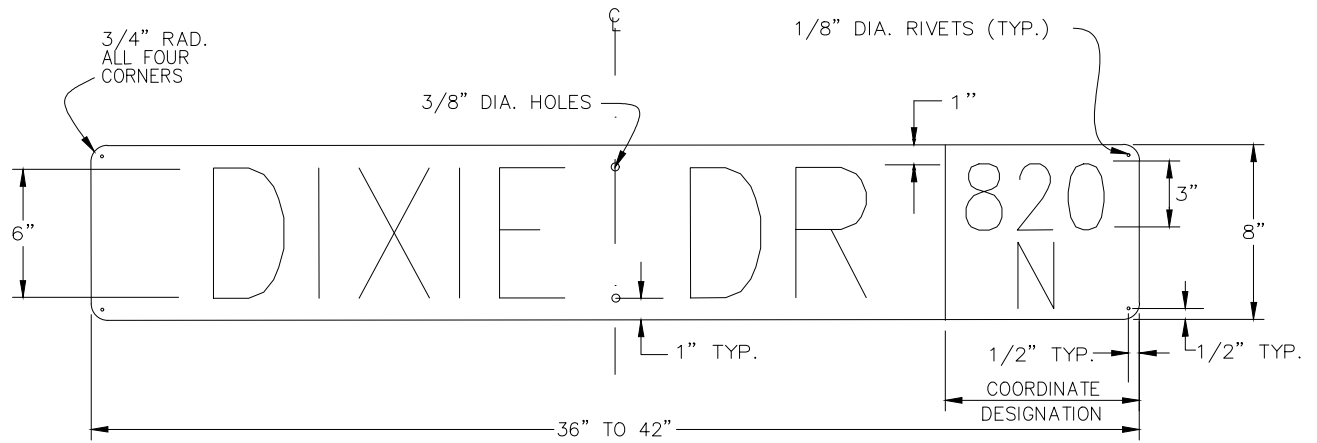

NOTES:

- 1- BACKGROUND SHALL BE GREEN, LEGEND AND LETTERS SHALL BE WHITE.
- 2- ALL SHEETING SHALL BE HIGH INTENSIRY REFLECTIVE SHEETING.
(FP-85 TYPE III A)
- 3- SIGNS SHOULD BE MADE BY THE "REVERSE OUT" PROCESS. NO STICK ON LETTERS.
CONTACT CITY SIGN SHOP FOR DETAILS.
- 4- SIGN BLANK SHALL BE 6061-T6 HEAT TREATED HIGH TENSILE DECREASED
ALUMINUM WITH ALODINE 1200 FINISH. MIN. THICKNESS SHALL BE 0.080".
- 5- EACH SIGN SHALL CONSIST OF TWO PLATES RIVETED TOGETHER
AND MOUNTED AS REQUIRED.
- 6- SIGNS ON PRIVATE ROADS ARE REQUIRED AND SHOULD MEET SAME SPECIFICATIONS
OF STANDARD SIGNS EXCEPT FOR BACKGROUND COLOR.
- 7- ALL STREETS WITH NAMES SHALL ALSO HAVE THE COORDINATE DESIGNATION ON THE
SIGN IN THE APPROPRIATE LOCATION UNLESS OTHERWISE APPROVED.
- 8- ADDRESS COORDINATOR SHALL BE CONTACTED PRIOR TO MAKING SIGNS
TO VERIFY PROPER NAMES AND COORDINATES.
- 9- ALL LETTERS SHALL BE UPPER CASE. LETTERS AND NUMBERS SHALL
CONFORM TO THE HEIGHT, WIDTH, STROKE WIDTH, AND SPACING AS PER THE
U.S. DEPT. OF TRANSPORTATION PUBLICATION "STANDARD ALPHABET
FOR HIGHWAY SIGNS".

CITY OF TOQUERVILLE

REVISIONS		
DATE	DESCRIPTION	BY

STANDARD STREET SIGN

STANDARD DWG. NO.	
400	1 OF 1
APPROVED:	
DATE:	BY: LBB

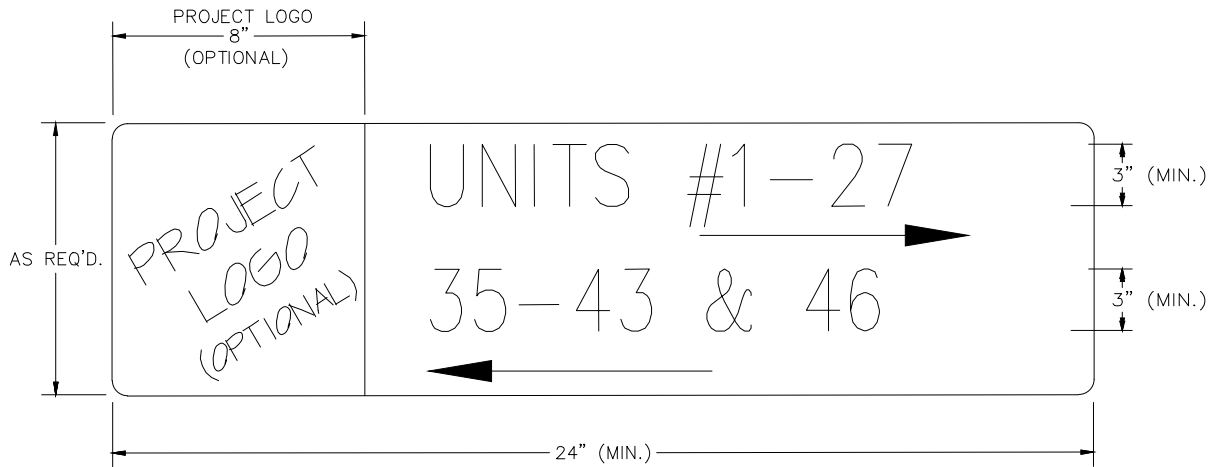

INTERIOR DIRECTIONAL SIGN



MAIN ENTRANCE STREET SIGN

NOTES:

- 1- SIGNS SHALL CONFORM TO CITY STREET SIGN STANDARDS AND SPECIFICATIONS.
- 2- STANDARD BACKGROUND IS BLUE. LETTERS AND LEGEND SHALL BE WHITE. SHEETING TYPE SHALL BE HIGH INTENSITY
- 3- SIGNS MOUNTED ON PUBLIC RIGHT OF WAY SHALL FOLLOW CITY INSTALLATION AND PLACEMENT STANDARDS. SAID STANDARDS ARE RECOMMENDED FOR INTERIOR SIGNS.
- 4- WHEN PROJECT IS ADDRESSED SIMILAR TO A SUBDIVISION WITH PUBLIC STREETS, THE ABOVE INTERIOR DIRECTIONAL SIGN IS NOT USED. SEE CITY ADDRESS COORDINATOR.
- 5- PROJECT LOGO, IF USED, MUST BE APPROVED BY THE CITY ADDRESS COORDINATOR PRIOR TO USE.

CITY OF TOQUERVILLE

REVISIONS		
DATE	DESCRIPTION	BY

PRIVATE STREET SIGNS

STANDARD DWG. NO.	
401	1 OF 1
APPROVED:	
DATE: 6/14/96	BY: LBB

SIGN DESIGNATION FORM

PROJECT NAME _____

DATE _____

BY _____

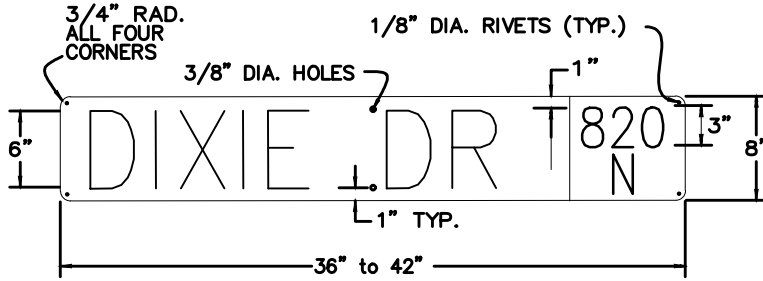

STANDARD ST. GEORGE CITY SIGN

THIS FORM TO BE COMPLETED BY THE CITY ADDRESS COORDINATOR PRIOR TO ORDERING OF STREET SIGNS BY DEVELOPER.

NOTES:

- 1- SEE DRAWINGS #400 & 401 FOR SIGN SPECIFICATIONS.
- 2- SIGNS ON PRIVATE ROADS WHEN REQUIRED BY THE CITY ENGINEER SHALL MEET ALL SPECIFICATIONS OF STANDARD SIGNS EXCEPT BACKGROUND SHALL BE BLUE.
- 3- ADDRESS COORDINATOR MUST BE CONTACTED PRIOR TO MAKING SIGNS TO VERIFY PROPER NAMES AND COORDINATES.
- 4- ALL STREETS WITH NAMES WILL ALSO HAVE COORDINATES DESIGNATED ON SIGN.

LOCATION GUIDE

	<input type="checkbox"/>	
	<input type="checkbox"/>	
	<input type="checkbox"/>	
	<input type="checkbox"/>	
	<input type="checkbox"/>	

CITY OF TOQUERVILLE

REVISIONS		
DATE	DESCRIPTION	BY

SIGN DESIGNATION FORM

STANDARD DWG. NO.	
402	1 OF 1
APPROVED:	
DATE: 6/20/96	BY: LBB

**TYPICAL SIDEWALK
INSTALLATION**

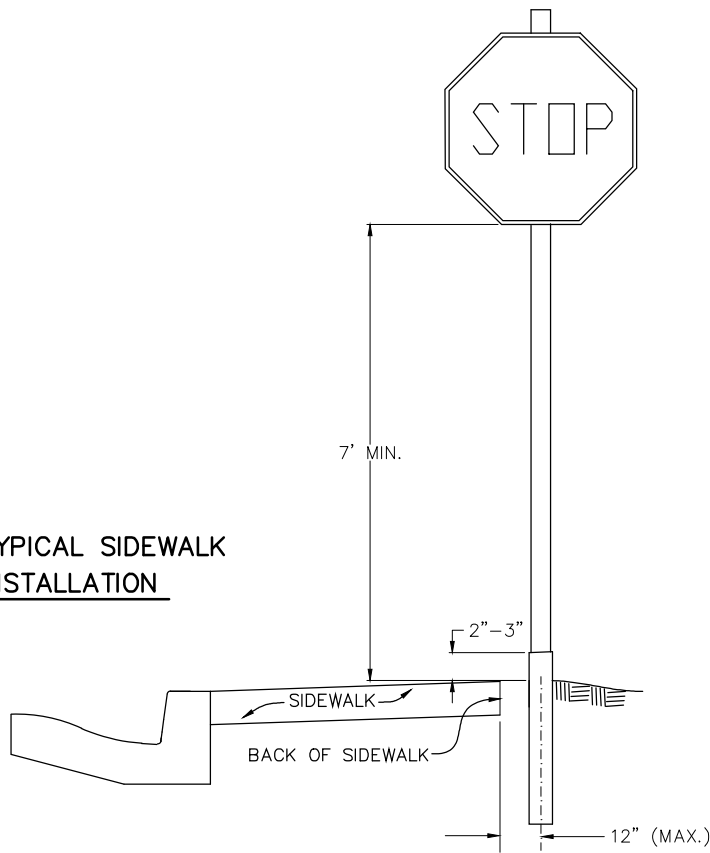

**TYPICAL RURAL
INSTALLATION**

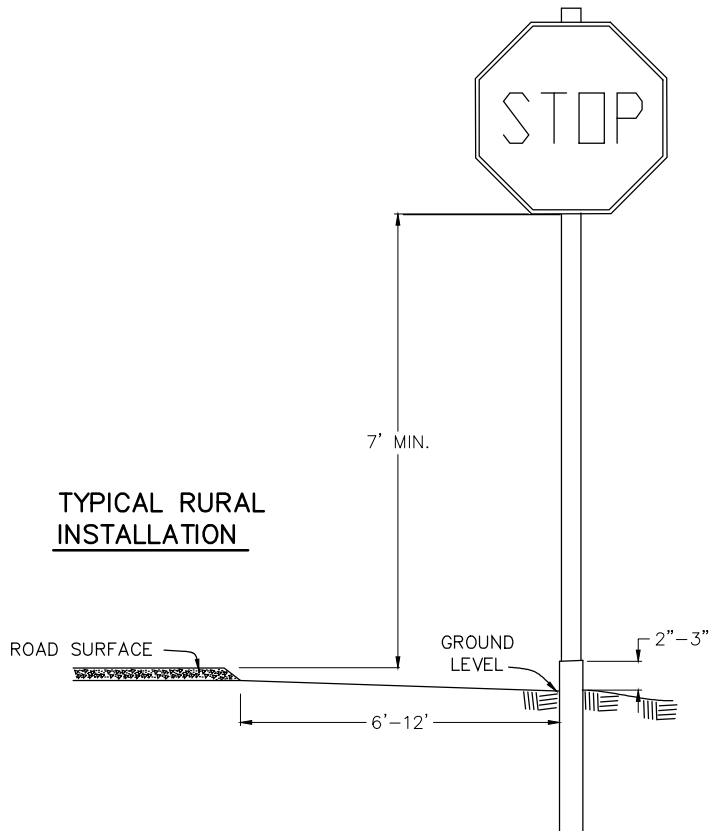

NOTES:

- 1- SIGNS SHALL BE PLACED IN CONFORMANCE WITH THE MANUAL ON UNIFORM TRAFFIC CONTROL DEVICES. (M.U.T.C.D.).
- 2- STREET NAME SIGNS SHALL BE REQUIRED ON ALL CITY STREETS.
- 3- ALL POST COMPONENTS SHALL BE GALVANIZED STEEL.
- 4- STREET NAME SIGNS PLACED ABOVE STOP SIGN SHALL BE AS SHOWN IN DRAWING 110 (2 OF 2).
- 5- WHERE PLANTER STRIP LIES BETWEEN SIDEWALK AND CURB, SIGNS SHALL BE INSTALLED IN PLANTER STRIP AS PER M.U.T.C.D.
- 6- SIGNS SHALL BE PLACED TO BE CLEARLY VISABLE. ALL OBSTRUCTIONS SUCH AS TREES, POLES, OTHER SIGNS, ETC, SHALL BE AVOIDED.

CITY OF TOQUERVILLE

REVISIONS		
DATE	DESCRIPTION	BY

**SIGN, POST AND INSTALLATION
DETAILS**

STANDARD DWG. NO.	
410	1 OF 1
APPROVED:	
DATE:	BY: LBB

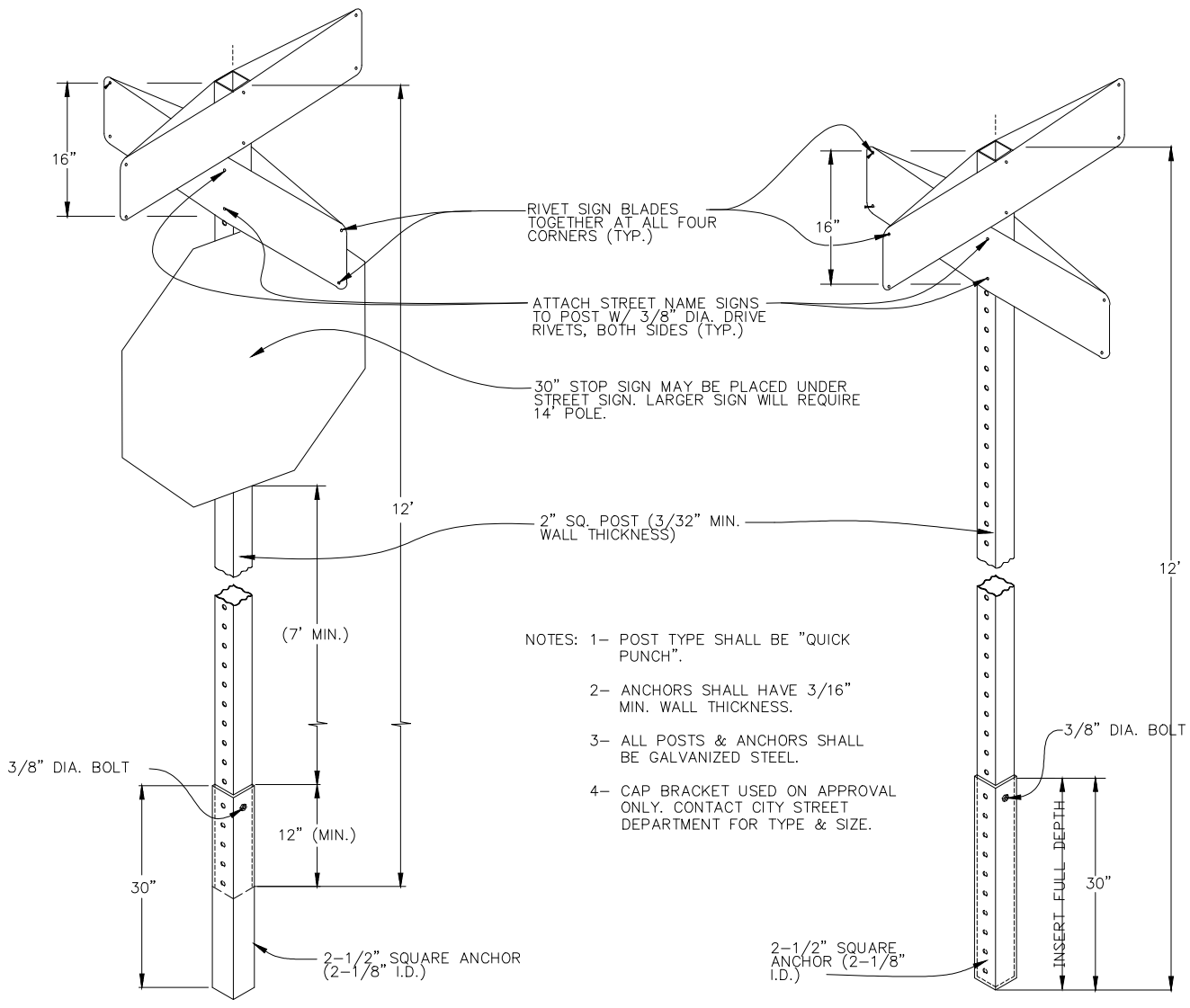

RIVET SIGN BLADES TOGETHER AT ALL FOUR CORNERS (TYP.)

ATTACH STREET NAME SIGNS TO POST W/ 3/8" DIA. DRIVE RIVETS, BOTH SIDES (TYP.)

30" STOP SIGN MAY BE PLACED UNDER STREET SIGN. LARGER SIGN WILL REQUIRE 14' POLE.

2" SQ. POST (3/32" MIN. WALL THICKNESS)

- NOTES: 1- POST TYPE SHALL BE "QUICK PUNCH".
 2- ANCHORS SHALL HAVE 3/16" MIN. WALL THICKNESS.
 3- ALL POSTS & ANCHORS SHALL BE GALVANIZED STEEL.
 4- CAP BRACKET USED ON APPROVAL ONLY. CONTACT CITY STREET DEPARTMENT FOR TYPE & SIZE.

INSTALLATION METHOD A

INSTALLATION METHOD B

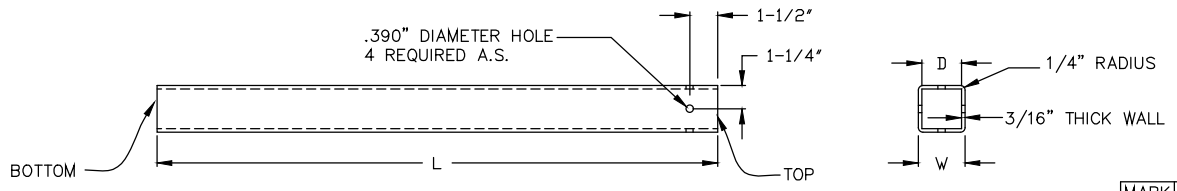

SIGN ANCHOR DETAIL

MARK	DIM.	TOLERANCE
D	2-1/8"	+1/16", -0"
L	30"	± 1/2"
W	2-1/2"	± 1/64"

CITY OF TOQUERVILLE

REVISIONS		
DATE	DESCRIPTION	BY

SIGN POST & MOUNTING DETAILS

STANDARD DWG. NO.	
411	1 OF 1
APPROVED:	
DATE:	BY: LBB

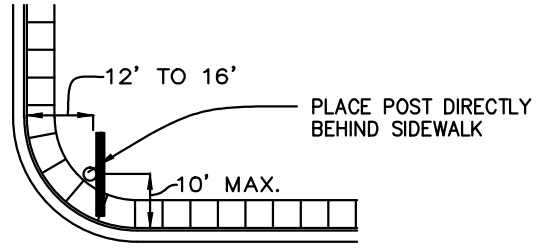
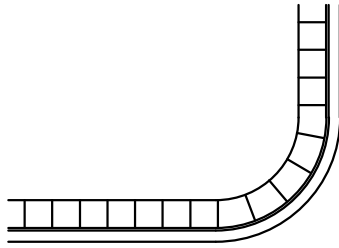

TYPICAL URBAN INSTALLATION

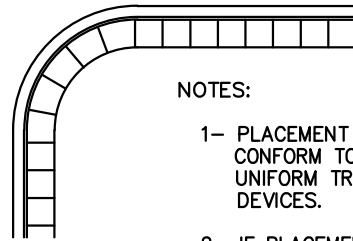
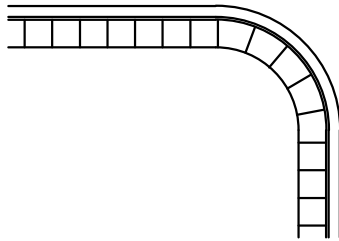

NOTES:

- 1- PLACEMENT OF ALL SIGNS TO CONFORM TO THE MANUAL ON UNIFORM TRAFFIC CONTROL DEVICES.
- 2- IF PLACEMENT STANDARDS CANNOT BE MET, CONTACT CITY ENGINEERING DEPARTMENT.
- 3- IF INSTALLATION ACCORDING TO STANDARDS CAUSES THE SIGN TO BE OBSTRUCTED OR ITS VISIBILITY IMPAIRED IN ANY WAY, MODIFICATIONS MAY BE NECESSARY. CALL ENGINEERING DEPT. FOR ASSISTANCE.

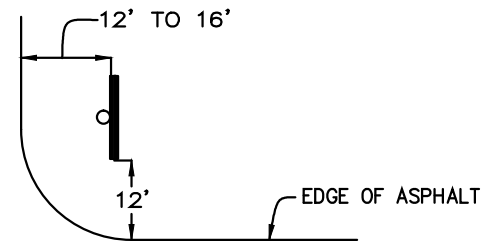
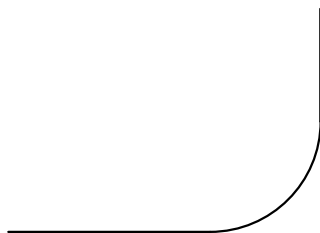

TYPICAL RURAL INSTALLATION

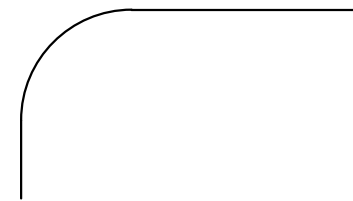
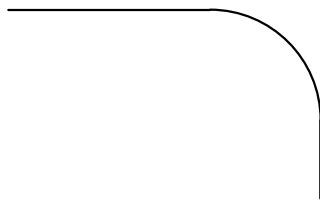

TOWN OF TOQUERVILLE

REVISIONS		
DATE	DESCRIPTION	BY

TYPICAL SIGN PLACEMENT DETAILS

STANDARD DWG. NO.	
412	1 OF 1
APPROVED:	
DATE:	BY: LBB