

# Agenda

# GRAND COUNTY Planning Commission

Tuesday, January 22, 2019  
5:00 P.M. Regular Meeting  
Grand County Courthouse  
Council Chambers  
125 E. Center St., Moab, Utah

<b>Type of Meeting:</b>	Regular Meeting
<b>Facilitator:</b>	Gerrish Willis, Chair
<b>Attendees:</b>	Planning Commissioners, interested citizens, and staff

<b>5:00 PM</b>	Citizens to be heard	<i>Chair</i>
<b>Action Item</b>	Seven Mile RV Park (CUP)	<i>Staff</i>
<b>Discussion Item</b>	Accessory Dwelling Unit's in HDH overlays	<i>Kevin Walker</i>
<b>Action Item</b>	Approval of January 8, 2019 Meeting Minutes	<i>Chair</i>
	Future Considerations	<i>Chair</i>
	Update on HDH Overlay Ordinance	<i>Staff</i>
	County Council Update – Terry Morse	<i>Council Liaison</i>
	<b>ADJOURN</b>	

## DEFINITIONS:

**Public hearing** = a hearing at which members of the public are provided a reasonable opportunity to comment on the subject of the hearing.

**Public meeting** = a meeting required to be open to the public pursuant to the requirements of Title 52, Chapter 4, Open and Public Meetings; the public may or may not be invited to participate.

**Legislative act** = action taken by the County Council or Planning Commission; amending ordinances, adopting general plan, Annexations, zoning and rezoning; a reasonable debatable action that could promote the general welfare of the community.

**Administrative act** = action taken by the Planning Commission, County Council or staff interpreting ordinances and regulations, conditional uses, approving subdivision, site plans, issuing building permits; an administrative decision must satisfy the requirements prescribed under state law or the County Land Use Code, whichever is stricter.

**Agenda Summary**  
**GRAND COUNTY PLANNING COMMISSION**  
**January 22, 2019**

<b>TITLE:</b>	Seven Mile Park Conditional Use Permit
<b>FISCAL IMPACT:</b>	N/A
<b>PRESENTER(S):</b>	Community and Economic Development Staff

**Prepared By:**  
**KENNY GORDON**  
**GRAND COUNTY**  
**PLANNING & ZONING**  
**ADMINISTRATOR**

**FOR OFFICE USE ONLY:**

**Attorney Review:**

N/A

**STATED MOTION :**

Move to forward a favorable recommendation to the Grand County Council with the following conditions:

- A final approval letter for the public water and sewer system will be provided prior to scheduling County Council review of a resolution to approve the conditional use.
- The Applicant will furnish an indemnification letter to the County regarding any future improvements to public rights-of-way as a result of this campground.

**STAFF RECOMMENDATION:**

Review and consider application materials provided to the planning commission related to the proposed Seven Mile Park campground. Staff recommends the planning commission move to forward a favorable recommendation to the Grand County Council with the noted conditions above.

**BACKGROUND:**

See staff report attached.

**ATTACHMENT(S):**

- Application & Applicant Statement
- Site Plan
- Title Report



# STAFF REPORT

## COMMUNITY DEVELOPMENT DEPARTMENT GRAND COUNTY

**DATE:** January 22, 2019  
**TO:** Grand County Planning Commission  
**SUBJECT:** Condition Use Permit

**PROPERTY OWNER** Lily Ann Balsley & Tracy Balsley  
**PROP. OWNER REP.** Tracy Balsley  
**ENGINEER** Anderson Engineering Inc.  
**PROPERTY ADDRESS** 2950 S. Hwy. 191  
**SIZE OF PROPERTY** 127 acres  
**EXISTING ZONE** Resort Special (RS)  
**EXISTING LAND USE** Residential and recreational parking

### ADJACENT ZONING AND LAND USE

Range and Grazing

### APPLICATION TYPE

Conditional Use Permit

### SUMMARY OF REQUEST

The subject property is 127 acres located on the west side of N. Hwy. 191, just south of the Moab Giants Dinosaur Museum. The Seven Mile Park will be comprised of 60 RV sites located on roughly 12 acres.

### SITE IMPROVEMENTS / ADDITIONS / CHANGES

The County maintains the Gemini Bridges Road, and UDOT plans to add a deceleration lane to the southbound side of Hwy. 191 (right-turn into property) in approximately one to two years. Applicant will provide water and sewer facilities as per the Southeastern Utah Health Inspector's approval. The Applicant will improve road surfaces interior to the project and ensure emergency vehicle access. No electricity will be provided. In general, the proposed campground will formalize and improve long-standing unauthorized camping in the vicinity.

### APPLICATION PROCEDURE

- Administrative
- Legislative
- Public Hearing at
  - Planning Commission
  - County Council
- Public Meeting at
  - Planning Commission
  - County Council

### ATTACHMENTS

- Approval Letters
- Site Plan
- Landscape Plan
- Vicinity Map
- Legal Notice
- Legal Description
- Public Comments
- Agency Comments
- Response to Standards
- Other:

**STAFF RECOMMENDATION:**

Approve

Approve with Conditions

Deny

Postpone

---

**CONSIDERATIONS FOR APPROVAL, DENIAL, AND/OR POSTPONEMENT**

3.2.3 Commercial Use Standards L. Recreational Vehicle/Travel Trailer Park

Recreational vehicle/ travel trailer parks shall comply with the following standards

1. Each space may be occupied only by persons using travel trailers, truck campers, small cabins (traditional KOA-style), and tents for overnight, short duration, or seasonal camping;
2. Each space RV/travel trailer space shall be at least 1200 square feet in area;  
*Confirmed*
3. Each cabin or tent space shall be at least 800 square feet in area;  
*No cabin or tent spaces are confirmed*
4. Each space shall be at least 30 feet in width;  
*Confirmed*
5. Each park shall be served by public water and sewer facilities;  
*The public water and sewer system will include a series of portable toilets, RV dump stations, potable water tanks, and water taps. The Southeastern Utah Health Inspector has provided verbal approval of the public water and sewer system, in general. At the time of writing this report, two minor design changes were being processed by the project engineer for resubmission to the Health Inspector. Final, written approval of the water and sewer system will be provided prior to County Council approval.*
6. No space shall be located more than 200 feet from a water and sewage service building;  
*Confirmed*
7. The County may require landscaping and screening pursuant to the provisions of Section 6.4, Landscaping and screening; and  
*The Applicant is not proposing and Staff is not recommending any landscaping or screening. It is understood that the proposed campground is improving long-standing unauthorized uses in the vicinity and addressing a growing issue of visitor use management in the Gemini Bridges area. Staff has worked closely with the Applicant for nearly two years to establish a formalized campground that can accommodate recreational vehicles that, to date, have utilized the Applicants' property in informal manners. Staff suggests the proposed solution is a beneficial outcome for Grand County residents and visitors.*
8. One (1) tree of a species suitable for the area shall be provided for each 2 spaces, and shall be located in close proximity to those spaces. (Existing trees on the site may be used to satisfy this requirement.)  
*Staff is recommending planning commission ignore this requirement given the soil quality and inaccessibility of irrigation water in the vicinity.*

*Continued on next page.*

## 9.11.6 Conditional Use Permit Considerations

### A. Effect on Environment

The location, size, design and operation characteristics of the proposed use shall not be detrimental to the health, welfare, and safety of the surrounding neighborhood or its occupants, nor be substantially or permanently injurious to neighboring property, nor cause substantial or permanent interference with the right to peaceful enjoyment of property.

*Staff anticipates an improvement/reduction of visitor use effects in the area due to the formal campground.*

### B. Compatible with Surrounding Area

The proposed site plan, circulation plan and schematic architectural designs shall be complementary with the character of the surrounding area with relationship to scale, height, landscaping and screening, building coverage, and density.

*The proposed campground fits with the character of the vicinity. It is nearby and partially located within the North Corridor Recreation area in the general plan and nearby a handful of other campgrounds and recreational facilities, as well as the Moab Giants Dinosaur Museum.*

### C. External Impacts Minimized

The proposed use shall not have negative impacts on existing uses in the area and in the county through the creation of noise, glare, fumes and odors, dust, smoke, vibration, fire hazard, excessive light, or other injurious or noxious impact. The applicant shall provide adequate mitigation responses to these impacts.

*The proposed campground will not exacerbate existing impacts of recreational use in the area, and is likely to improve/reduce visitor use effects in the area. It should not increase any visitor related impacts on the County.*

### D. Infrastructure Impacts Minimized

The proposed use shall not have negative impacts on existing uses in the area and in the county through impacts on public infrastructure such as roads, parking facilities and water and sewer systems, and on public services such as police and fire protection and solid waste collection, and the ability of existing infrastructure and services to provide services adequately.

*The proposed campground will create some additional vehicular impacts on Gemini Bridges Road. The County Engineer and Road Supervisor have reviewed the proposed plans and estimated average daily trips (ADTs) resulting from the campground and believe the current road standards suffice. The RV dump stations and portable toilets will create some additional impacts on the City of Moab's recently constructed wastewater treatment plant, but such impacts are considered minimal. Potable water take-outs from the culinary water system will increase, and vehicular trips for water and sewer trucks between the City of Moab and the proposed development will increase.*

### E. Consistent with LUC and General Plan

The proposed use will be consistent with the purposes of this LUC, the General Plan, and any other statutes, ordinances or policies that may be applicable, and will support rather than interfere with the uses otherwise permitted in the zone in which it is located.

*See next text box.*

### F. Parcel Size

The proposed use may be required to have additional land area, in excess of the lot area otherwise allowed by the underlying zoning district, as necessary to ensure adequate mitigation of impacts on surrounding land uses and the zoning district.

*The Seven Mile Park will be comprised of 60 RV sites located on roughly 12 acres. Additional land is not needed to accommodate the proposed use.*

## COMPATABILITY WITH GENERAL PLAN

Staff believes the proposed campground is supported by the General Plan. Specifically, the following elements of the General Plan are noted:

Chapter 3.2 (Vision: Recreation and Access), Goal 1, Strategy E - Encourage development proposals that include dedication of easements that maintain access through historic corridors and to public lands and connect to existing and planned trails.

Chapter 3.2 (Vision: Recreation and Access), Public Lands –  
Campgrounds: Public Lands Policy 20. Encourage federal land agencies to continue to coordinate with the County on proposed campground development and expansion, specifically for areas within close proximity to Moab.

While the proposed campground isn't clearly or wholly located within the "North Corridor Recreation" polygon of the Future Land Use Map, it is very close and, in staff's opinion, clearly within a highly used recreation area. The Gemini Bridges road is a historic, public road that is heavily trafficked.

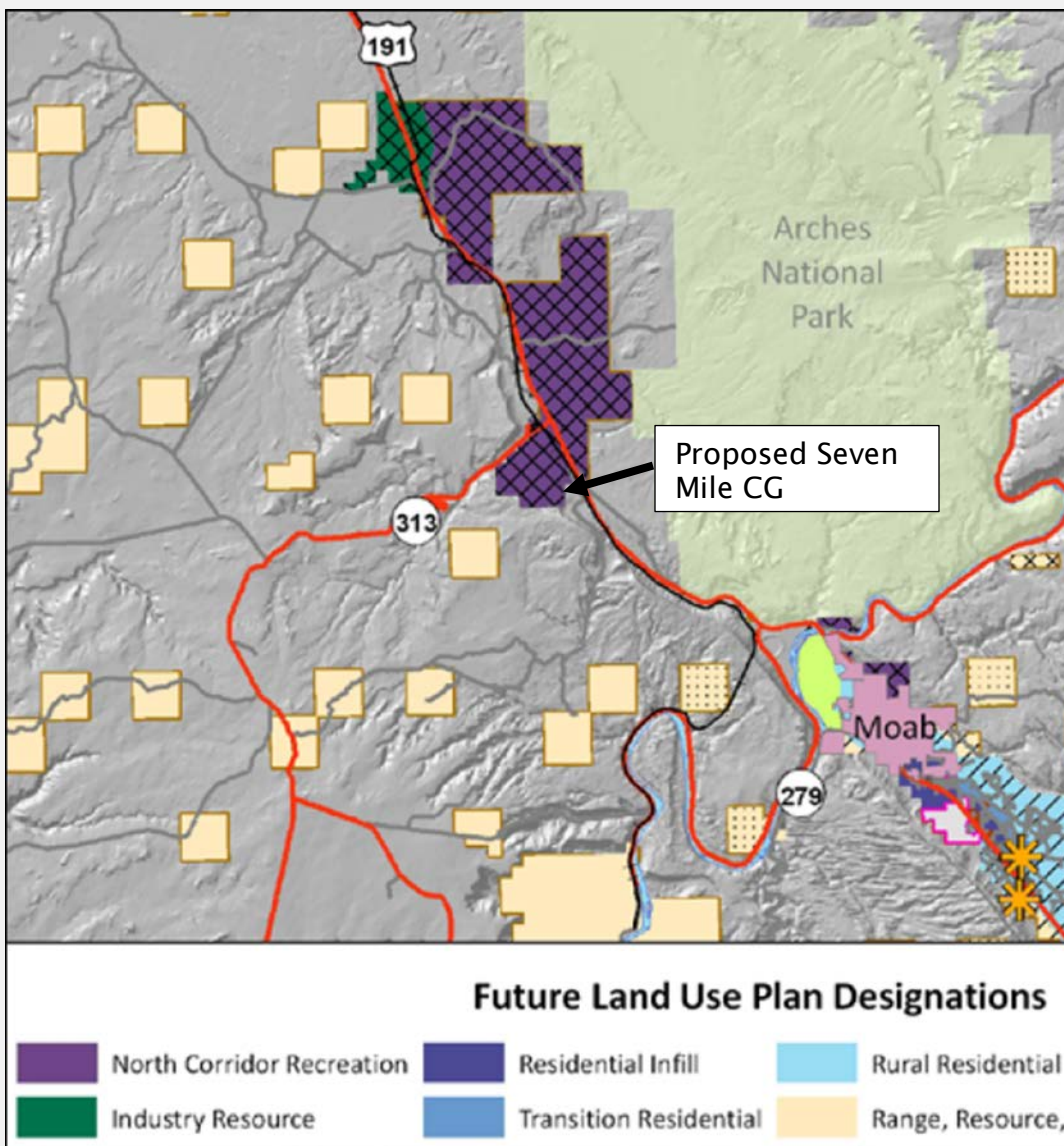

## COMPATABILITY WITH LAND USE CODE (ZONING)

The subject property was rezoned from Range and Grazing (RG) to Resort Special (RS) in 2017. Campgrounds are conditional uses within the RS zone. Staff has reviewed the subject application and finds it compliant with the pertinent Land Use Code.

## LAND USE CODE REFERENCE SECTIONS

### Section 3.1 Use Table

Principal Uses by Zoning District														
Use Category	Specific Use	RESIDENTIAL					NONRESIDENTIAL						Use-Specific Standards	
		SLR	LLR	RR	MFR	RG	NC	GB	RC	RS	HC	LI		HI
Key: P = Permitted by right C = Conditional Use Permit Required ___ Not Permitted (Use-specific Standards and descriptions of Use Categories are provided in 3.2 and 3.4, respectively)														
Overnight Accommodations	Bed and breakfast					P		P	P	P	P			3.2.3D
	Dude ranch or destination resort					C								3.2.3F
	Hotel or motel						P	P	P	P	P			
	Recreational vehicle parks and campgrounds								C	C	C			3.2.3L
	Residential units used for overnight accommodation							P	P	P	P			3.2.3M
	All other overnight accommodation uses													4.6.4

### Section 3.2.3L Recreational Vehicle Parks and Campgrounds (See Use Specific Standards Above)

Articles 5 and 6 related to Development Standards and Section 9.11 Conditional Use Permits.

The County Engineer and Road Supervisor have reviewed the proposed campground plans and find them in compliance with the County's standards. Stipulations related to road maintenance and emergency vehicle access have been incorporated into the site plans and operating policies. UDOT has provided approval for the project.

## PROPERTY HISTORY

The Gemini Bridges Road, which is a public right of way, crosses the subject property. This road is designated under a RS-2477 claim. The Road Supervisor has included stipulations indemnifying the County from making any improvements to Gemini Bridges Road as a result of the proposed development. The Applicant is maintaining a 44 foot wide ROW with a 24' surface width from Hwy. 191 to the connection with Gemini Bridges Rd. A Union Pacific railroad line also crosses the subject property. An easement granted by the property owner to Union Pacific governs the access and maintenance of this railroad line. The County's conditional use approval in no way addresses or modifies this easement, and the County will not be held liable for any legal issues that arise between the property owner and easement owner.

Exploration of a formal campground development emerged a couple years back when the Applicant was compelled to formalize parking and waste management at the Gemini Bridges Rd. turnoff. Visitor use was increasing exponentially, but the lack of a formal campground created challenging management issues for the property owners. Staff supports this application because it will clean-up and formalize long-standing unauthorized uses in the vicinity.



## CONDITIONAL USE APPLICATION

Grand County Courthouse: 125 E. Center St. Moab, UT 84532; Phone: (435)259-1343

**FOR OFFICE USE ONLY**

Date of Submittal: \_\_\_\_\_ Conditional Use Processing Fees: **\$550.00**  
Submittal Received by: \_\_\_\_\_ Amount Paid: \_\_\_\_\_ Fees Received by: \_\_\_\_\_

**CONTACT INFORMATION**

**Property owner:** Lily ANN Balsley and Tracy BALSLEY  
**Address:** 257 SUNDIAL DRIVE MOAB, UT 84532  
**Phone:** 435-259-2356 **cell:** 435-260-1656  
**fax:** \_\_\_\_\_  
**Email address:** LilyAnn.Balsley@GMAIL.COM

**Engineer:** ANDERSON ENGINEERING INC.  
**Address:** 5520 SOURDOUGH RD. BOZEMAN, MT 59715  
**Phone:** 406-925-0590 **cell:** SAME **fax:** \_\_\_\_\_  
**Email address:** bill@ANDERSONMONTANA.COM

**Property owner representative:** TRACY BALSLEY  
**Address:** 2950 S. HWY 191 MOAB, UT 84532  
**Phone:** 435-259-6408 **cell:** 435-260-1593 **fax:** \_\_\_\_\_  
**Email address:** tracebalsley@frontiernet.net

**PROJECT INFORMATION**

**Project name:** SEVEN MILE PARK LLC  
**General location of the property:** MM 135.4 Hwy 191 MOAB, UT 84532  
**Size of the subject property:** 127 acres  
**Current Zoning:** RESORT SPECIAL district

**REQUIRED SIGNATURES** (or attach letter of approval by the agency)

• Agency will review for ability to serve the lots and adequate existing and future easements.

✗ Moab Valley Fire Department \_\_\_\_\_

✗ Grand County Road Supervisor or UDOT \_\_\_\_\_



Grand Water and Sewer Service Agency \_\_\_\_\_  
Rocky Mountain Power \_\_\_\_\_  
FEMA Floodplain Adm. \_\_\_\_\_ (provide map of site)

### SUBMITTAL REQUIREMENTS

Conditional Use Permit applications shall contain, at a minimum, the following supporting materials through the approval process according to the following submittal schedule:

1. **APPLICATION SUBMISSION.** Two complete sets of all supporting materials shall be submitted with this application. These complete sets should include one large (24" x 36") set as well as one electronic copy. If the plans are not approved as submitted, two corrected large sets of plans, one small set of plans, and one electronic copy of plans shall be submitted that comply with the Zoning Administrator's approval.
2. **PRIOR TO MEETING.** Revised sets of plans shall be submitted prior to the application being placed on a Planning Commission /County Council meeting. (Check with Planning Department)
3. **POST MEETING.** If the revised sets of plans are not approved as submitted two corrected sets of plans shall be submitted that comply with the Planning Commission's approval.

**Site Plan (& Survey if applicable).** The applicant shall submit a site plan (and certified survey if applicable) of the proposed land area. The site plan shall require, at a minimum, the following information:

1. Subject land area acreage;
2. Adjacent uses and predominant uses in the vicinity;
3. Existing zoning designation within 100 feet of the exterior boundary of the parcel;
4. Drives, streets, and rights-of-way; (LUC Sec. 6.2)
5. Easements;
6. Landscaping and screening; (LUC Sec. 6.4)
7. Location and dimensions of structures and signs; (LUC sign regulation Sec. 6.5)
8. Typical elevations of such buildings;
9. Access ways, including points of ingress, egress;
10. Topography; and
11. Specific areas proposed for specific types of land use.

Additional Information required for Site Plan review if there is new construction or occupancy changes.

1. Parking; (LUC Sec. 6.1)
2. Sidewalks and trails;
3. Fences and walls; (LUC Sec. 6.3)
4. Location and type of lighting; (LUC Sec. 6.6)
5. Building elevations;
6. Any areas in a natural drainage or the 100 year floodplain; (\*LUC Sec. 6.7 and 6.8)
7. Any areas with slopes in excess of 30 percent;
8. Existing and proposed easements, areas proposed for public dedication.
9. Compatibility Standards (LUC Sec.6.10)

\*A drainage plan shall be required if proposing installation of more than 7,000 square feet of impervious area.

**Applicant Statement.** A written statement by the Applicant explaining the rationale for the conditional use request relative to the Conditional Use Criteria imposed by Sec 9.11.6, Grand County LUC and the Use Specific standards for the proposed use. In making its determination, the County Council shall consider the recommendation of the Planning Commission, staff reports, and the written and oral testimony presented, and the following criteria:

**Sec. 9.11.6 Conditional Use Criteria:**

**A. Effect on Environment**

The location, size, design and operation characteristics of the proposed use shall not be detrimental to the health, welfare, and safety of the surrounding neighborhood or its occupants, nor be substantially or permanently injurious to neighboring property, nor cause substantial or permanent interference with the right to peaceful enjoyment of property.

**B. Compatible with Surrounding Area**

The proposed site plan, circulation plan and schematic architectural designs shall be complementary with the character of the surrounding area with relationship to scale, height, landscaping and screening, building coverage, and density.

**C. External Impacts Minimized**

The proposed use shall not have negative impacts on existing uses in the area and in the county through the creation of noise, glare, fumes and odors, dust, smoke, vibration, fire hazard, excessive light, or other injurious or noxious impact. The applicant shall provide adequate mitigation responses to these impacts.

**D. Infrastructure Impacts Minimized**

The proposed use shall not have negative impacts on existing uses in the area and in the county through impacts on public infrastructure such as roads, parking facilities and water and sewer systems, and on public services such as police and fire protection and solid waste collection, and the ability of existing infrastructure and services to provide services adequately.

**E. Consistent with LUC and General Plan**

The proposed use will be consistent with the purposes of this LUC, the General Plan, and any other statutes, ordinances or policies that may be applicable, and will support rather than interfere with the uses otherwise permitted in the zone in which it is located.

**F. Parcel Size**

The proposed use may be required to have additional land area, in excess of the lot area otherwise allowed by the underlying zoning district, as necessary to ensure adequate mitigation of impacts on surrounding land uses and the zoning district.

**Use-specific Standards.** Check with the Planning Office for information regarding the use specific standards required for the proposed use you are requesting.

**Title Report.** A preliminary title report from a licensed title company or attorney listing the name of the property owner(s) and all liens, easements and judgments of record affecting the subject property, and of the preliminary plat.

**Posting.** The applicant is responsible for posting a sign noticing the public hearings (please see attached for a reduced size template and requirements). The applicant is responsible for wind and water proofing the sign as well as placing it in a prominent place on the land area proposed for subdivision with a notice of the hearing at least 10 days prior to the public hearings.

**Application Fee.** The process / filing fee of \$550.00 shall be paid in full – additional engineer fees may apply.

**Operating Data & Evaluation.** Any and all information, operating data and expert evaluation necessary to clearly explain the location, function and characteristics of any building or use proposed;

**APPLICANT CERTIFICATION**

---

I certify under penalty of perjury that this application and all information submitted as a part of this application are true, complete and accurate to the best of my knowledge. I certify that if I am the owner of the subject property and that the authorized agent noted in this application has my consent to represent me with respect to this application. Should any of the information or representations submitted in connection with this application be incorrect or untrue, I understand that Grand County may rescind any approval, or take any other legal or appropriate action. I also acknowledge that I have reviewed the applicable sections of the Grand County Land Use Code and that items and checklists contained in this application are basic and minimum requirements only and that other requirements may be imposed that are unique to individual projects or uses. Additionally, I have reviewed and understand the section from the Consolidated Fee Schedule and hereby agree to comply with this resolution. I also agree to allow the Staff, or County appointed agent(s) of the County to enter the subject property to make any necessary inspections thereof.

Property Owner's Signature Lyle Ann Baldrey / Tracy Baldrey Date: 9/28/18

# THE SLOAN LAW FIRM, PLLC

Christina R. Sloan  
sloan@thesloanlawfirm.com  
www.thesloanlawfirm.com  
\* licensed in UT and CO

76 S. Main Street, Ste. 1  
Moab, UT 84532  
435.259.9940

September 28, 2018

Zacharia Levine  
Community and Economic  
Development Director  
125 E. Center Street  
Moab, Utah 84532

***Re. RV Park CUP Application – Seven Mile Park (13543 N. Hwy 191, Moab)***

Dear Zacharia,

On behalf of my clients, the Balsley Family, please find enclosed a Conditional Use Application for a 60-site RV Park on 127 acres of real property zoned Resort Special and known as 13543 N. Highway 191, Moab, Utah 84532 (Parcel Nos. 04-0020-0045 and 04-0020-0064). The Application is comprised of the following:

1. Applicant Statement (below);
2. Application fee for \$550.00;
3. Conditional Use Application;
4. Legal descriptions of both subject properties;
5. Tax Parcel Records for both subject properties;
6. Title Report from AO Title for both subject properties;
7. Site Plan, Topo Map, and Engineering Plans from Anderson Engineering, Inc. (plus two 11x17" copies);
8. June 8, 2018 letter from Orion Rogers (Health Dept) re. soils testing;
9. December 20, 2017 email from Kurt McFarlane (UDOT) re. access approval;
10. September 24, 2018 Project Notification Form and Variance Request for the Seven Mile Park Water System, which system DDW assigned No. 10046; and
11. September 20, 1962 Railroad Easement.

The primary access into the Seven Mile Park will be on the existing dirt road known as Gemini Bridges Road, which crosses through the deeded Railroad Easement referenced above now owned by the Union Pacific Railroad ("RR"). Please note that because the access from Highway 191 is existing, no further UDOT access permits are required. Also, as we have discussed, the RR has recently declined to participate in discussions regarding how and if the RR wants or will upgrade the RR crossing located between Seven Mile Park and Highway 191 on Applicant's property. I have five unreturned emails and voicemails in to Lance Kippen on this matter.

Regardless, this issue should not delay County action on the CUP Application. Pursuant to the express terms of the RR Easement, as consideration of the original easement grant to the RR, the RR promised “permanent access” to Grantor and “other interested parties” across the RR Easement via a crossing to be provided by the RR. Under long-standing principles governing contract interpretation, we must give intent to this broad and expressly non-exclusive language in the RR Easement. By 1962, Gemini Bridges Road was already a primary route for travelers, jeepers, and miners. Thus, the Parties both intended to protect existing uses of the road at the time of conveyance as well as protect Grantors rights to develop their Property.

Of course, in the last 60 years, many millions of people have and do access the now-popular Gemini Bridges area for year-round recreation over and through the RR crossing. And, the Seven Mile Park has no real impact on traffic trips over the Gemini Bridges Road. In fact, the Seven Mile Park grew out of a need to control the dozens of people that were illegally camping on Applicant’s property, the surrounding private property, and BLM land every weekend in the busy seasons, on their way to the Gemini Bridges area. Thus, while this CUP Application may be a trigger for reviewing the crossing, the cost to improve it cannot be saddled on the Applicants. If the County were to deny the Seven Mile Park, it would not reduce the number of people driving across the RR crossing or using the Gemini Bridges Road.

**Applicant Statement:**

A. Effect on Environment. The subject property is 127 acres located on the west side of N. Hwy 191, just south of the Moab Giants Dinosaur Museum. The Seven Mile Park will disturb only a small area of the subject properties, and the visual impact to surrounding neighbors is minimal compared to the nearby Dinosaur Museum. In addition, Applicants have worked with the County and the Division of Drinking Water to minimize water waste by consolidating water supply to three central water taps and one central waste dump station. Thus, the proposed use will have little to no impact on the environment.

B. Compatibility with Surrounding Area. The Seven Mile Park will be comprised of 60 RV sites. Thus, there are no architectural, scale, or height concerns with the proposed use. In addition, most of the surrounding land on all sides is BLM land, which has been historically used for dispersed camping. Thus, the proposed use is compatible with the current and historical use and character of the surrounding area.

C. External Impacts. Not only will the Seven Mile Park not create external negative impacts, the Seven Mile Park grew out of a desire to address existing negative impacts occurring on Applicants’ property and adjacent lands: namely, illegal camping and dumping (of trash and human waste). By providing folks with a legal camping area, with water and sewage facilities, the Seven Mile Park will address current impacts associated with recreational use of this popular area.

D. Infrastructure Impacts. The County already maintains the Gemini Bridges Road, and UDOT plans to add a turning lane to Gemini Bridges Road in approximately one to two years. In addition, Applicants will provide water and sewage facilities. Thus, the Seven Mile Park will have no negative impacts on existing public infrastructure.

E. Consistency with the LUC and General Plan. The property is zoned Resort Special, which zoning supports the proposed use. In addition, the proposed use supports further development of the Northern Recreation Corridor along Highway 191, as envisioned by the General Plan. Thus, the proposed use is consistent with the LUC and General Plan.

F. Parcel Size. The subject properties total 127 acres in size, of which the Seven Mile Park will use and disturb only a small area, leaving sufficient property for parking, buffering, drainage, water storage, and drain fields.

Please let me know if you have any concerns or need additional documentation from the Balsley Family to move forward on this Application. Thank you for your consideration.

Sincerely,

THE SLOAN LAW FIRM, PLLC



---

Christina R. Sloan

CRS/  
cc: Balsley Family  
Bill Anderson  
Enclosures

**Shirley OKelly**

---

**From:** Kurt McFarlane <kmcfarlane@utah.gov>  
**Sent:** Wednesday, December 20, 2017 8:03 AM  
**To:** Shirley OKelly  
**Subject:** Re: Seven Mile Park/Balsley

Shirley,

We have started working with the county for the turn lanes, we will see if it goes anywhere, but we are trying.

I do not have a good contact for the Railroad.

I will keep you posted on what happens for your property, it will take a while to get it moving. But we do not plan on holding up your project, as far as I know. My guess is the turn lanes will be a couple years out.

Thanks for meeting with us,

Kurt McFarlane  
UDOT - Permits  
[kmcfarlane@utah.gov](mailto:kmcfarlane@utah.gov)  
435-650-1156



Virus-free. [www.avg.com](http://www.avg.com)



**SEVEN MILE PARK  
GRAND COUNTY, UTAH  
SECTION 2, T25S, R20E  
SITE PLAN**

- SITE PLAN NOTES:**
1. DRY RV SITES. NO SEWER/WATER HOOKS UP PROVIDED.
  2. ALL SITES ARE RESTRICTED TO OCCUPATION BY PERSONS USING A TRAVEL TRAILER, TRUCK CAMPER, AND TOY HAULER FOR OVERNIGHT, SHORT DURATION, OR SEASONAL CAMPING.
  3. 60 TOTAL RV SITES.
  4. TENT CAMPING ALLOWED FOR EVENTS AND TEMPORARILY IF PROVIDED WITH WASH AND RESTROOM FACILITIES AS NEEDED.

**LEGEND**

- PROPERTY LINE
- SECTION LINES
- EXISTING EDGE OF ASPHALT
- EXISTING PAVEMENT
- EXISTING RIGHT OF WAY
- EXISTING CENTERLINE OF RAILROAD TRACK
- EXISTING OVERHEAD POWER
- EXISTING FENCE
- EXISTING DIRT ROAD
- EXISTING DRAINAGE FLOW LINES
- EDGE OF GRAVEL
- COUNTY SETBACKS
- NUMBERED DRY RV SPACES
- TRAFFIC FLOW ARROWS
- GRAVEL AND TREATED BASE
- WATER SUPPLY TAP
- WATERLINE - 1.25" HDPE
- WATERLINE VALVE
- 4" SEWER LINE, MINIMUM SLOPE 2.08%

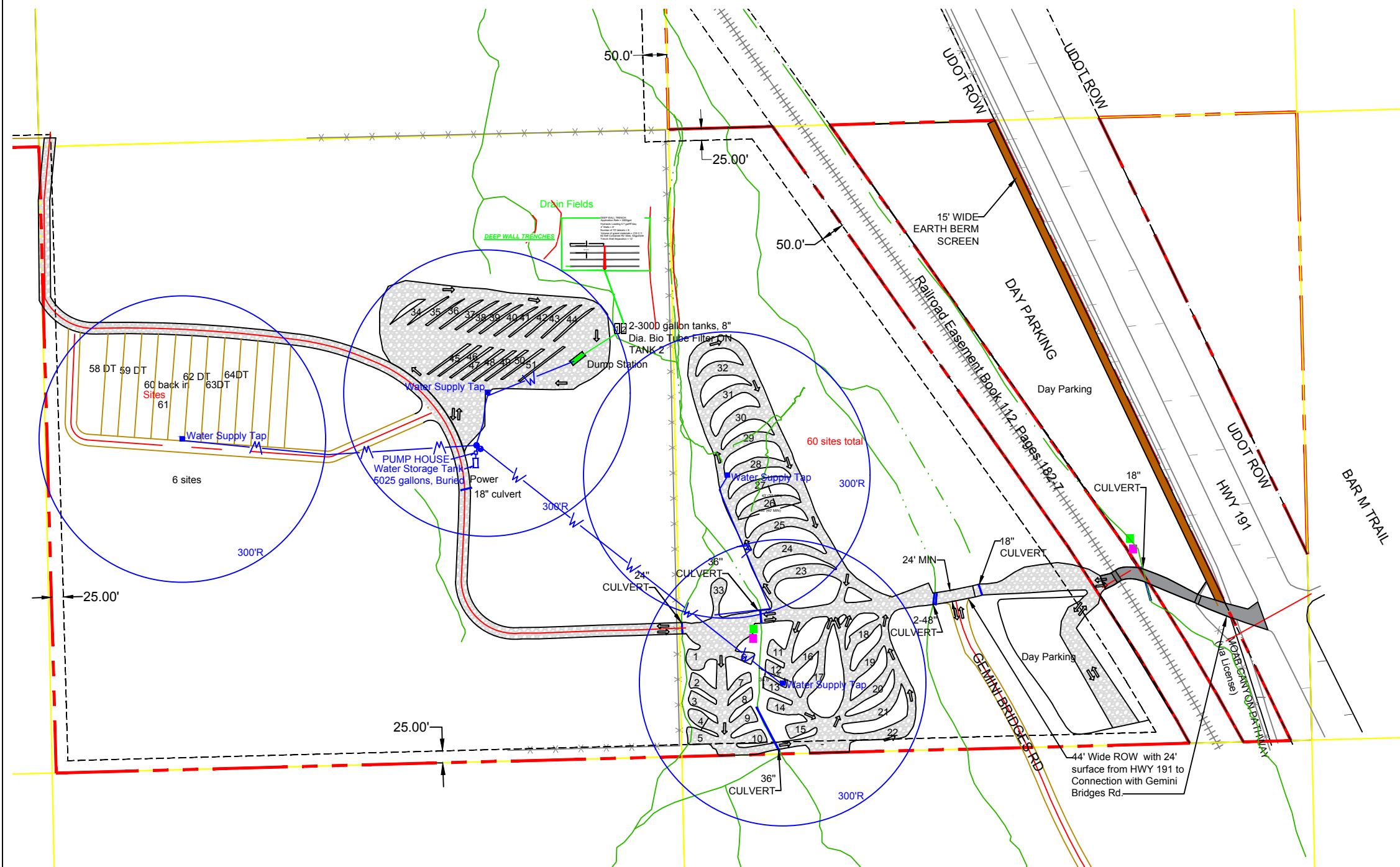

PROFESSIONAL ENGINEER  
172473  
WILLIAM ANDERSON  
12/29/18  
STATE OF UTAH

William H. Anderson, P.E.

Donald Butler, 00425-OSP-2  
12/29/18

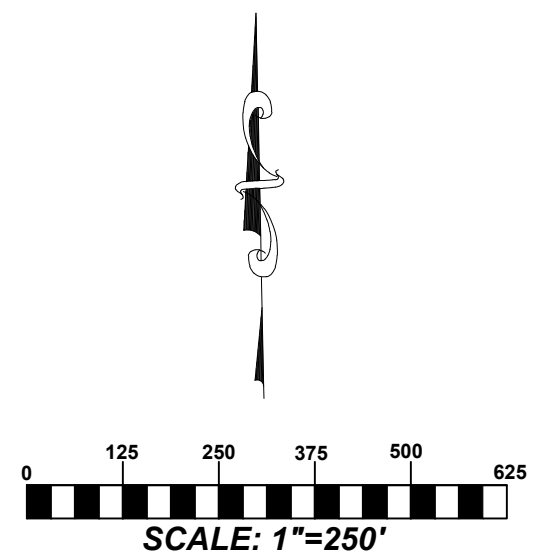
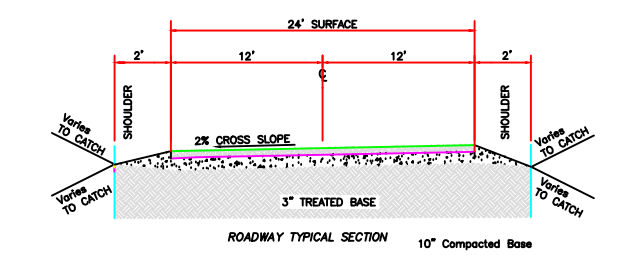
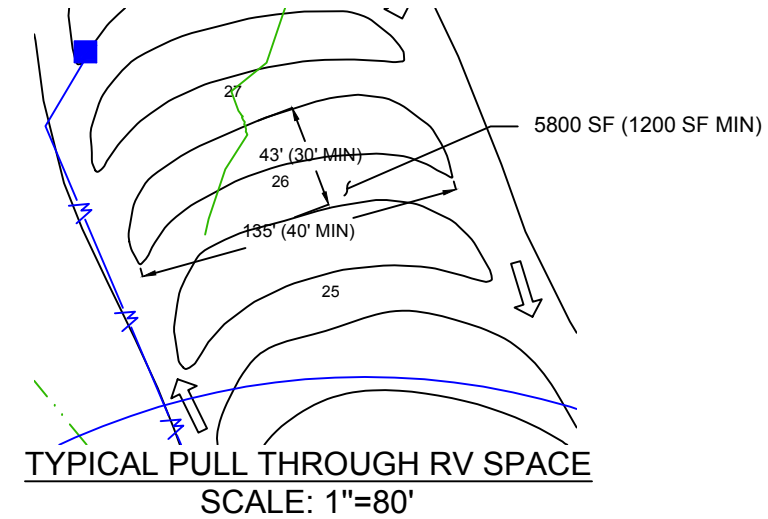
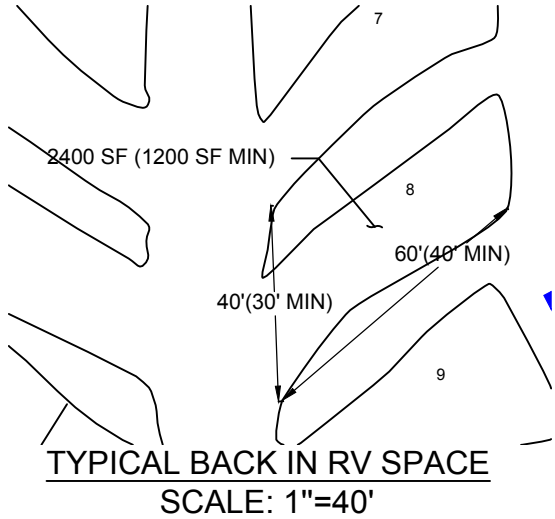

Date: 08/08/18  
Drawn By: MS  
Checked By: WHA  
Revisions:  
Seepage Trench  
Health Comments  
Septic Tank Loc.



**GRAND COUNTY CORPORATION**  
**Tax Roll Master Record**

August 3, 2018

3:35:09PM

Parcel: 04-0020-0045	Serial #:25-20-2-19	Entry: 504213
Name: BALSLEY LILY ANN	Property Address	
c/o Name: BALSLEY TRACY	N HWY 191 13543 (SEVEN MILE FLAT)	
Address 1: 257 SUNDIAL	MOAB	84532-0000
Address 2:	Acres: 40.00	
City State Zip: MOAB UT 84532-0000		
Mortgage Co:		
Status: <b>Active</b>	Year: <b>2018</b>	District: <b>004 COUNTY GENERAL</b>
		<b>0.009900</b>

Owners	Interest	Entry	Date of Filing	Comment
BALSLEY LILY ANN	JT	504213	08/30/2013	(0799/0788)
BALSLEY TRACY	JT	504213	08/30/2013	(0799/0788)

Property Information	2018 Values & Taxes				2017 Values & Taxes		
	Units/Acres	Market	Taxable	Taxes	Market	Taxable	Taxes
BC03 COMMERCIAL BLDG	0.00	82,878	82,878	820.49	0	0	0.00
BR08 PRIMARY MANUFACTURED HOME	0.00	9,873	5,430	53.76	0	0	0.00
LC01 COMMERCIAL IMPROVED	5.00	61,746	61,746	611.29	0	0	0.00
LR01 RES. IMPROVED LAND	1.00	5,000	2,750	27.23	5,000	2,750	27.95
LV01 LAND VACANT	34.00	50,585	50,585	500.79	7,350	7,350	74.69
Totals:	40.00	210,082	203,389	2,013.56	12,350	10,100	102.64

Property Type	Year Built	Square Footage	Basement Size	Building Type
BR08 PRIMARY MANUFACTURED HOME	1977	672		SFR

\*\*\*\* **SPECIAL NOTE** \*\*\*\*

Tax Rates for 2018 have NOT BEEN SET OR APPROVED! Any levied taxes or values shown on this printout for the year 2018 are SUBJECT TO CHANGE!! (Using Proposed Tax Rate)

2018 Taxes:	2,013.56	2017 Taxes:	102.64
Special Fees:	0.00	<b>Review Date</b>	<b>05/15/2018</b>
Penalty:	0.00	<b>NO BACK TAXES!</b>	
Abatements: (	0.00)		
Payments: (	0.00)		
Amount Due:	2,013.56		

**NO BACK TAXES**

GRAND COUNTY TREASURER / DEPUTY

\_\_\_\_\_  
signature

DO NOT USE THIS TAXING DESCRIPTION FOR LEGAL PURPOSES OR OFFICIAL DOCUMENTS. For taxing purposes only. Consult property deeds for full legal description.

**Taxing Description**

NE¼SW¼ SEC 2 T25S R20E 40.00 AC

**History**

QCD BOOK 504 PAGE 538 CLEARS TITLE, SPLIT PROPERTIES NEW PARCELS 04-0020-0066 04-0020-0067

**GRAND COUNTY CORPORATION  
Tax Roll Master Record**

August 3, 2018

3:35:09PM

Parcel: 04-0020-0064	Serial #:25-20-2-16 15 11 5 6	Entry: 491216
Name: BALSLEY LILY ANN		
c/o Name:		
Address 1: 257 SUNDIAL		
Address 2:		
City State Zip: MOAB	UT 84532-0000	Property Address
Mortgage Co:		N HWY 191 13542 (SEVEN MILE FLAT)
Status: <b>Active</b>	Year: <b>2018</b>	MOAB 84532-0000
	District: <b>004 COUNTY GENERAL</b>	Acres: 87.00
		<b>0.009900</b>

Owners	Interest	Entry	Date of Filing	Comment
BALSLEY LILY ANN	59.12%	491216	04/13/2009	(0746/0638)
BALSLEY FAMILY TRUST	40.88%	491216	04/13/2009	(0746/0638)

Property Information	2018 Values & Taxes				2017 Values & Taxes		
	Units/Acres	Market	Taxable	Taxes	Market	Taxable	Taxes
LV01 LAND VACANT	87.00	14,550	14,550	144.05	14,550	14,550	147.86
Totals:	87.00	14,550	14,550	144.05	14,550	14,550	147.86

<p><b>**** SPECIAL NOTE ****</b>                  Tax Rates for 2018 have NOT BEEN SET OR APPROVED! Any levied taxes or values shown on this printout for the year 2018 are SUBJECT TO CHANGE!! (Using Proposed Tax Rate)</p>	2018 Taxes: 144.05 Special Fees: 0.00 Penalty: 0.00 Abatements: ( 0.00) Payments: ( 0.00) Amount Due: 144.05	2017 Taxes: 147.86  <p align="center"><b>Review Date 04/10/2017</b></p> <p align="center"><b>NO BACK TAXES!</b></p>
---	---	---

**NO BACK TAXES**

GRAND COUNTY TREASURER / DEPUTY

\_\_\_\_\_  
signature

**DO NOT USE THIS TAXING DESCRIPTION FOR LEGAL PURPOSES OR OFFICIAL DOCUMENTS.** For taxing purposes only. Consult property deeds for full legal description.

**Taxing Description**

THE S'LY HALF OF LOTS 13; 14; THE PORTION OF LOT 15 LYING E'LY OF UTAH DEPARTMENT OF TRANSPORTATION HWY 191 R-O-W; THE NWSE OF SEC 2 T25S R20S <<<<>> TOGETHER WITH A NON-EXCLUSIVE R-O-W 20 FT IN WIDTH FOR A WATER LINE THE C/L OF WHICH IS THE WATER LINE EXISTING IN PLACE ACROSS THE N'LY & W'LY SIDES OF LOT 12 & THE N'LY 1/2 OF LOT 13 SEC 2 T25S R20E & FOR ACCESS TO THE GRANTEE'S WELL SITUATE ON SAID LOT 12 INCLUDING THE RIGHT TO ACCESS THE SAME IN ORDER TO MAINTAIN; REPAIR & REPLACE THE WATER LINE & WELL <<<<>> A NON-EXCLUSIVE EASEMENT 100 FT BY 100 FT CENTERED AT & FOR GRANTEE'S WELL IN PLACE ON LOT 12 SEC 2 T25S R20E <<<<>> SUBJECT TO A NON-EXCLUSIVE RIGHT OF WAY FOR ACCESS & UTILITIES 60 FT WIDE RUNNING A GENERALLY SE'LY DIRECTION FROM THE N'LY BOUNDARY OF THE S 1/2 ACROSS LOT 14 & THE NWSE SEC 2 T25S R20E SLBM PARALLEL & ADJACENT TO & W'LY OF THE W'LY BOUNDARY OF THE D&RG RAILROAD (UNION PACIFIC) R-O-W TO ITS INTERSECTION WITH THE GEMINI BRIDGES ACCESS ROAD IN PLACE AND ALONG SAID GEMINI BRIDGES ROAD IN AN E'LY DIRECTION TO ITS INTERSECTION WITH THE UTAH STATE HWY 191 R-O-W. SAID EASEMENT IS -----(DESC ENDS AT THIS PT)

**History**

EN 501017 SPLITS 04-020-0046; NEW NUMBERS 04-020-0066 & 04-020-0067

# Schedule A

File No.: 59,492-G

(PR ONLY \$450.00)

Reference File Number/Order Number:

1. Effective Date: June 2, 2017 @ 8:00 A.M.

2. Policy (or Policies) to be issued: N/A

Policy Amount      Policy Fee

a. ALTA Standard Owner's Policy of Title Insurance

\$TBD

\$TBD

Proposed Insured:      N/A

b. ALTA Loan Policy of Title Insurance

\$TBD

\$TBD

Proposed Insured:      N/A

c. Endorsements Alta 8.1-06, Alta 9-06, Alta 22-06

\$ N/A

3. Title to the fee simple surface estate or interest in the land is at the Effective Date vested in:

**Parcel 1**

**LILY ANN BALSLEY AND TRACY BALSLEY, as joint tenants**

**Parcel 2**

**LILY ANN BALSLEY, individually, as to an undivided 59.12%**  
**LILY ANN BALSLEY, as Trustee of THE BALSLEY FAMILY TRUST, created under the**  
**Last Will and Testament of Thomas Howard Balsley aka Thomas H. Balsley, dated May 6, 2000,**  
**as to an undivided 40.88%**

4. The land referred to in this Commitment is situated in the State of Utah, County of Grand and is described as follows:

**SEE EXHIBIT "A"**

**EXHIBIT "A"**

**PARCEL 1:**

**NE1/4SW1/4, SECTION 2, T25S, R20E, SLBM, GRAND COUNTY, UTAH.**

**EXCEPTING** therefrom all coal and other minerals, that have been previously reserved or transferred in prior documents.

**TOGETHER WITH THE FOLLOWING EASEMENT ESTATE:**

**A perpetual right-of way from U.S. Highway No. 160, 50 feet in width over the existing right-of way, crossing the D&RGW Railroad right of way, thence due west to the 40 acres above conveyed, as disclosed in the Warranty Deed, recorded July 21, 2000 in Book 550 at page 427 as entry no. 451799.**

**ALSO: A right-of way for a railroad spur from the existing railroad to the land hereby conveyed 100 feet in width over the NW1/4SE1/4, Section 2, T25S, R20E, SLBM, which right-of-way shall be more accurately described as soon as the railroad agrees on its location.**

**PARCEL 2:**

**THE SOUTHERLY 1/2 OF LOTS 13 AND 14, THAT PORTION OF LOT 15 LYING EASTERLY OF UTAH DEPARTMENT OF TRANSPORTATION HIGHWAY 191 RIGHT OF WAY, THE NW1/4SE1/4, ALL IN SECTION 2, T25S, R20E, SLBM, GRAND COUNTY, UTAH.**

**LESS ANY PORTION WITHIN STATE HIGHWAY 191.**

**EXCEPTING** therefrom all coal and other minerals, that have been previously reserved or transferred in prior documents.

**TOGETHER WITH THE FOLLOWING EASEMENT ESTATE:**

**A non-exclusive right of way 20 feet in width for a water line, the centerline of which is the water line existing in place across the northerly and westerly sides of Lot 12 and the northerly 1/2 of Lot 13, Section 2, T25S, R20E, SLBM and for access to the Grantees' well situate on said Lot 12, including the right to access the same in order to maintain, repair and replace the water line and well, as disclosed in the Referees' Deed, recorded April 13, 2009 in Book 746 at page 638 as entry no. 491216.**

**ALSO: A non-exclusive easement 100 foot by 100 foot centered at and for Grantees' well in place on Lot 12, Section 2, T25S, R20E, SLBM, for the purpose of which shall be to permit Grantees' to maintain, repair and replace said well, and to exercise Grantees' water rights in connection with said well to the greatest extent permitted by law.**

# Schedule BI

File No.: 59,492-G

## REQUIREMENTS

The following requirements must be satisfied: N/A

1. Payment of the necessary consideration for the estate or interest to be insured.
2. Pay all premiums, fees and charges for the policy.
3. Documents creating the estate or interest to be insured, must be properly executed, delivered and recorded.
4. Payment of all taxes and/or assessments levied against the subject premises which are due and payable.
5. **The owner and any previous owners within the last 6 months are required to sign a statement that no recent construction has taken place. A physical inspection may also be required. If recent construction has taken place, additional requirements may be added.**
6. Release(s) or Reconveyance(s) of item(s):

# Schedule BII

File No.: 59,492-G

## EXCEPTIONS

The policy or policies to be issued will contain exceptions to the following matters unless the same are disposed of to the satisfaction of the Company: N/A

1. The Lien of Real Estate Taxes or assessments imposed on the title by a governmental authority that are not shown as existing Liens in the Records of any taxing authority that levies taxes or assessments on real property or in the Public Records.
2. Any facts, rights, interests, or claims that are not shown in the Public Records but that could be ascertained by an inspection of the Land or by making inquiry of persons in possession of the Land.
3. Easements, claims of easement or encumbrances that are not shown in the Public Records.
4. Any encroachment, encumbrance, violation, variation, or adverse circumstance affecting the Title including discrepancies, conflicts in boundary lines, shortage in area, or any other facts that would be disclosed by an accurate and complete land survey of the Land and not shown in the Public Records.
5. Unpatented mining claims; reservations or exceptions in patents or in Acts authorizing the issuance thereof; water rights, claims or title to water.
6. Any lien or right to a lien for services, labor or material theretofore or hereafter furnished, imposed by law and not shown in the Public Records.

**PARCEL 1:**

Taxes for the year 2017 now accumulating not yet due plus any other assessments including but not limited to Special Service Districts and Personal property taxes. Claim, right, title or interest to water or water rights whether or not shown by the public records. Taxes for the year 2016 were paid in the amount of \$101.29. The 2017 Personal Property taxes were paid in the amount of \$21.86 on tax # HT-04-0034.

Tax Parcel Number: **04-0020-0045**

7. Said land is located within the boundaries of Grand County and may be subject to taxes or assessments levied by said District.
8. Any rights, title or interests in coal, oil, gas and minerals of any kind, together with any associated rights to mine or remove said minerals. The Title Company does not purport to disclose documents of record pertaining to the above referenced rights however, the following was found of record: Any claim, right, title or interest under the Reservation of all coal and other minerals as reserved by the State of Utah in the Patent, recorded November 16, 1955 in Book 3H at page 251 as entry no. 272466. Title Company has not verified the vested current owner of this severed interest.
9. Ditches, canals, easements, rights of way or fence lines that may be established upon said land.
10. Access for ingress and egress for land in Section 2, T25S, R20E, SLBM, is subject to the terms and conditions of a Right of Way Contract, by and between Howard W. Balsley, Anna R. Rath, Rosemary Rath Carson, Beth Elaine Rath Bell, Nancy Carolyn Rath, August F. Rath and The Denver and Rio Grande Western Railroad Company, recorded September 20, 1962 in Book 112 at page 182 as entry no. 299330.
11. Terms and conditions of a Transmission Line Easement in favor of Utah Power & Light Company, recorded September 2, 1970 in Book 186 at page 236 as entry no. 335644.

**PARCEL 2:**

12. Taxes for the year 2017 now accumulating not yet due plus any other assessments including but not limited to Special Service Districts and Personal property taxes. Claim, right, title or interest to water or water rights whether or not shown by the public records. Taxes for the year 2016 were paid in the amount of \$145.92.

Tax Parcel Number: **04-0020-0064**

13. Said land is located within the boundaries of Grand County and may be subject to taxes or assessments levied by said District.
14. Any rights, title or interests in coal, oil, gas and minerals of any kind, together with any associated rights to mine or remove said minerals. The Title Company does not purport to disclose documents of record pertaining to the above referenced rights however, the following was found of record: Any claim, right, title or interest under the Reservation of all coal and other minerals as reserved by the State of Utah in the Patent, recorded November 16, 1955 in Book 3H at page 251 as entry no. 272466. Title Company has not verified the vested current owner of this severed interest.

15. Ditches, canals, easements, rights of way or fence lines that may be established upon said land.
16. Terms and conditions of a Pole Line Easement in favor of Utah Power & Light Company, recorded March 30, 1954 in Book 6M at page 560 as entry no. 222388 AND Terms and conditions of a Pole Line Easement in favor of Utah Power & Light Company, recorded July 8, 1955 in Book 6Q at page 132 as entry no. 267887.
17. Terms and conditions of a Pipe Line Easement in favor of Pacific Northwest Pipeline Corporation, recorded August 23, 1956 in Book 6-S at page 110 as entry no. 279621.
18. Terms and conditions for highway known as Project No. 013-2 situated in Lot 15 and NW1/4SE1/4 of Section 2, T25S, R20E, SLM, in favor of The State Road Commission of Utah as disclosed in the Warranty Deed, recorded May 29, 1956 in Book 3H at page 488 as entry no. 276087.
19. Terms, conditions and provisions of the Right Of Way Contract in favor of The Denver and Rio Grande Western Railroad Company, recorded September 20, 1962 in Book 112 at page 182 as entry no. 299330.
20. Terms and conditions of an Easement in favor of Utah Power & Light Company, recorded June 2, 1972 in Book 196 at page 559 as entry no. 339962.
21. Terms and conditions of a Grant of Easement in favor of MAPCO, Inc., recorded December 18, 1980 in Book 315 at page 529 as entry no. 388732.
22. Terms, conditions and provisions of the Referees' Deed regarding Case No. 0507-107 in the Seventh District Court, Moab, State of Utah, recorded April 13, 2009 in Book 746 at page 638 as entry no. 491216.

A judgment, federal tax lien, Utah State bankruptcy, and National SDN search was made in the following names.

Owners: **LILY ANN BALSLEY, individually and as Trustee, TRACY BALSLEY,  
THE BALSLEY FAMILY TRUST**

TITLE INQUIRIES concerning this Commitment can be directed to:  
Leanne Blackmon/Title Agent ~ [leanne@southeasttitle.com](mailto:leanne@southeasttitle.com)

EMAIL CLOSING DOCUMENTS TO:  
Chantyll Navarre/Escrow Agent ~ [chantyll@southeasttitle.com](mailto:chantyll@southeasttitle.com)

Chain of Title

According to the Official Records, as of the Effective Date, there have been no documents conveying the land described herein within a period of 24 months prior to the date of this commitment except as follows:

Doc	Grantor	Grantee	Rec Date	Entry No.	Book	Page
None were found recorded within the last 24 months						



Parcel 1

# GRAND COUNTY CORPORATION Tax Roll Master Record

May 3, 2017

3:43:08PM

Parcel: 04-0020-0045	Serial #:25-20-2-19	Entry:
Name: BALSLEY LILY ANN		
c/o Name: BALSLEY TRACY		Property Address
Address 1: 257 SUNDIAL		N HWY 191 MILE POST 135-4
Address 2:		MOAB 84532-0000
City State Zip: MOAB UT 84532-0000		Acres: 40.00
Mortgage Co		
Status: <b>Active</b>	Year: <b>2017</b>	District: <b>004 COUNTY GENERAL</b>
		<b>0.010029</b>

Owners	Interest	Entry	Date of Filing	Comment
BALSLEY LILY ANN	JT	504213	08/30/2013	(0799/0788)
BALSLEY TRACY	JT	504213	08/30/2013	(0799/0788)

Property Information	2017 Values & Taxes				2016 Values & Taxes		
	Units/Acres	Market	Taxable	Taxes	Market	Taxable	Taxes
LR01 RES. IMPROVED LAND	1.00	5,000	2,750	27.58	5,000	2,750	27.58
LV01 LAND VACANT	39.00	7,350	7,350	73.71	7,350	7,350	73.71
Totals:	40.00	12,350	10,100	101.29	12,350	10,100	101.29

**\*\*\*\* SPECIAL NOTE \*\*\*\***  
 Tax Rates for 2017 have NOT BEEN SET OR APPROVED! Any levied taxes or values shown on this printout for the year 2017 are SUBJECT TO CHANGE!!

2017 Taxes:	101.29	2016 Taxes:	101.29
Special Fees:	0.00	<b>Review Date</b>	
Penalty:	0.00	<b>05/07/2012</b>	
Abatements: (	0.00)	<b>NO BACK TAXES!</b>	
Payments: (	101.29)		
Amount Due:	0.00		

01/01/2017 11:22AM 00107017 2017 BALSLEY LILY ANN #4494	Current - Check	101.29	treasurera
	Total Payments:	101.29	

### Legal Description

NE¼SW¼ SEC 2 T25S R20E 40.00 AC

40  
87  
-----  
127

GRAND COUNTY CORPORATION  
**Tax Roll Master Record**

May 3, 2017

3:42:29PM

Parcel: 04-0020-0064	Serial #:25-20-2-16 15 11 5 6	Entry:
Name: BALSLEY LILY ANN		
c/o Name:		
Address 1: 257 SUNDIAL		
Address 2:		
City State Zip: MOAB	UT 84532-0000	Property Address
Mortgage Co		SEVEN MILE FLAT RD EXT
Status: <b>Active</b>	Year: <b>2017</b>	MOAB 84532-0000
	District: <b>004 COUNTY GENERAL</b>	Acres: 87.00
		<b>0.010029</b>

Owners	Interest	Entry	Date of Filing	Comment
BALSLEY LILY ANN	59.12%	491216	04/13/2009	(0746/0638)
BALSLEY FAMILY TRUST	40.88%	491216	04/13/2009	(0746/0638)

Property Information	2017 Values & Taxes				2016 Values & Taxes		
	Units/Acres	Market	Taxable	Taxes	Market	Taxable	Taxes
LV01 LAND VACANT	87.00	14,550	14,550	145.92	14,550	14,550	145.92
Totals:	87.00	14,550	14,550	145.92	14,550	14,550	145.92

\*\*\*\* **SPECIAL NOTE** \*\*\*\*  
 Tax Rates for 2017 have NOT BEEN SET OR APPROVED! Any levied taxes or values shown on this printout for the year 2017 are SUBJECT TO CHANGE!!

2017 Taxes:	145.92	2016 Taxes:	145.92
Special Fees:	0.00	<b>Review Date</b>	
Penalty:	0.00	<b>04/12/2012</b>	
Abatements: (	0.00)	<b>NO BACK TAXES!</b>	
Payments: (	145.92)		
Amount Due:	0.00		

01/01/2017 11:22AM 00107017 2017 BALSLEY LILY ANN #4494	Current - Check	145.92	treasurera
	Total Payments:	145.92	

**Legal Description**

THE S'LY HALF OF LOTS 13; 14; THE PORTION OF LOT 15 LYING E'LY OF UTAH DEPARTMENT OF TRANSPORTATION HWY 191 R-O-W; THE NWSE OF SEC 2 T25S R20S <<<>>> TOGETHER WITH A NON-EXCLUSIVE R-O-W 20 FT IN WIDTH FOR A WATER LINE THE C/L OF WHICH IS THE WATER LINE EXISTING IN PLACE ACROSS THE N'LY & W'LY SIDES OF LOT 12 & THE N'LY 1/2 OF LOT 13 SEC 2 T25S R20E & FOR ACCESS TO THE GRANTEE'S WELL SITUATE ON SAID LOT 12 INCLUDING THE RIGHT TO ACCESS THE SAME IN ORDER TO MAINTAIN; REPAIR & REPLACE THE WATER LINE & WELL <<<>>> A NON-EXCLUSIVE EASEMENT 100 FT BY 100 FT CENTERED AT & FOR GRANTEE'S WELL IN PLACE ON LOT 12 SEC 2 T25S R20E <<<>>> SUBJECT TO A NON-EXCLUSIVE RIGHT OF WAY FOR ACCESS & UTILITIES 60 FT WIDE RUNNING A GENERALLY SE'LY DIRECTION FROM THE N'LY BOUNDARY OF THE S 1/2 ACROSS LOT 14 & THE NWSE SEC 2 T25S R20E SLBM PARALLEL & ADJACENT TO & W'LY OF THE W'LY BOUNDARY OF THE D&RG RAILROAD (UNION PACIFIC) R-O-W TO ITS INTERSECTION WITH THE GEMINI BRIDGES ACCESS ROAD IN PLACE AND ALONG SAID GEMINI BRIDGES ROAD IN AN E'LY DIRECTION TO ITS INTERSECTION WITH THE UTAH STATE HWY 191 R-O-W. SAID EASEMENT IS -----(DESC ENDS AT THIS PT)

**"SOUTHEASTERN UTAH TITLE COMPANY"  
 FURNISHES THIS PLAT SOLELY FOR THE  
 PURPOSE OF ASSISTING IN LOCATING THE  
 LAND. THE TITLE COMPANY ASSUMES NO  
 LIABILITY FOR VARIATIONS WITH AN ACTUAL  
 SURVEY OR DEED DESCRIPTION.**

**SECTION 2 T25S R20E SLB&M**

SCALE: 1" = 500'

THIS PLAT WAS PREPARED FROM THE ORIGINAL  
 SURVEY OF THE ABOVE DESCRIBED SECTION BY  
 W. H. BROWN & COMPANY, INC., SALT LAKE CITY,  
 UTAH, IN 1908.

ENTER ISSUED  
 THE ROBERT W. SMITH  
 THE JOHN H. BAKER  
 W. H. BROWN & COMPANY  
 W. H. BROWN & COMPANY

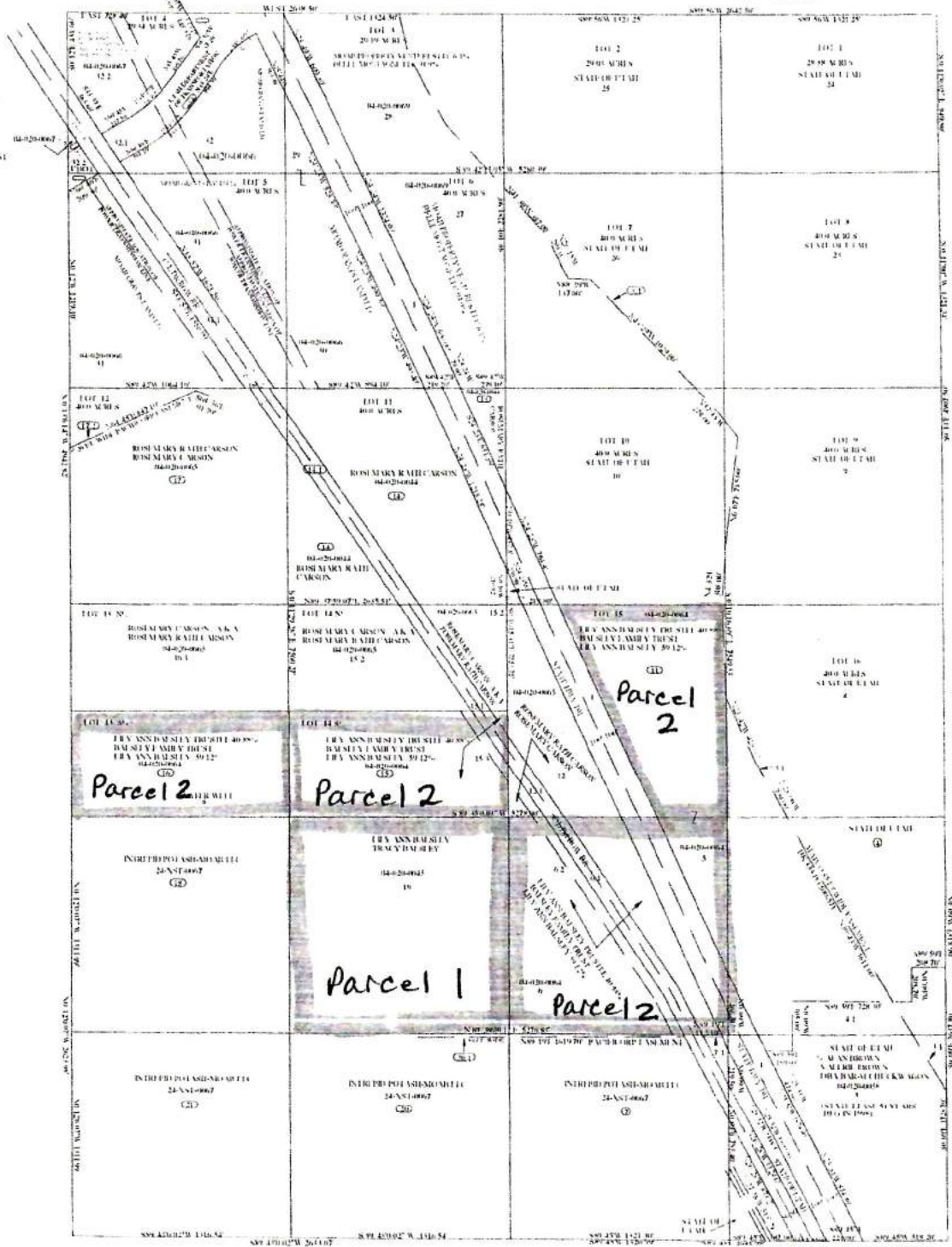

THE INFORMATION CONTAINED HEREIN IS  
 BELIEVED TO BE TRUE AND CORRECT AS  
 SHOWN BY THE SURVEY AND AS SET FORTH  
 IN THE RECORDS OF THE

**Agenda Summary**  
**GRAND COUNTY PLANNING COMMISSION**  
**January 22, 2019**

<b>TITLE:</b>	Discussion: ADU allowances within the recently approved HDH Overlay
<b>FISCAL IMPACT:</b>	N/A
<b>PRESENTER(S):</b>	Kevin Walker, Planning Commissioner

**Prepared By:**  
**ZACHARIA LEVINE**  
**GRAND COUNTY**  
**COMMUNITY &**  
**ECONOMIC**  
**DEVELOPMENT**  
**DIRECTOR**

**FOR OFFICE USE ONLY:**

**Attorney Review:**

N/A

**STATED MOTION :**

N/A

**STAFF RECOMMENDATION:**

N/A

**BACKGROUND:**

Kevin Walker asked to place this discussion item on the agenda. The question is in regards to ADU allowances within developments receiving approval through the HDH Overlay ordinance, and whether or not ADUs should be counted towards the maximum density of the applied HDH district.

**ATTACHMENT(S):**

ADOPTED HDH Overlay Ordinance

**GRAND COUNTY, UTAH  
ORDINANCE \_\_\_\_\_ (2019)**

**ORDINANCE ADOPTING NEW CHAPTER 4.7 HIGH DENSITY HOUSING  
(HDH) OVERLAY DISTRICTS TO THE GRAND COUNTY LAND USE  
CODE**

**WHEREAS, the purpose of this ordinance is to:**

- A. Encourage the development and availability of housing that is accessible and affordable to a broad range of households with varying income levels within the County;
- B. Promote the County's goal to add housing units to the County's housing stock that may be owned or rented by households actively employed within the County;
- C. Facilitate new development in a compact and orderly manner;
- D. Minimize the impacts of new development on existing neighborhoods and residents within HDH districts;
- E. Reduce the cost of constructing and maintaining infrastructure associated with new development;
- F. Actualize the affordable housing goals and policies identified in the Grand County General Plan, which includes incentives for increasing density in strategically identified areas throughout the County;

**WHEREAS, the County Council finds and determines:**

- A. The Moab Area, which includes the City of Moab, Town of Castle Valley, and unincorporated areas of Grand County, faces a serious housing problem that threatens its economic security, quality of life, and environment. The extreme lack of access to affordable housing has a direct impact upon the health, safety, and welfare of residents of the County. While no single housing program will solve all of the Area's needs, the High Density Housing (HDH) Overlay has been identified as one solution among a broader set of solutions;
- B. Population in the Moab Area has increased rapidly, reflecting overall trends in the State of Utah. Between 2000 and 2017, the population in Grand County rose from 9,225 to 10,292, equivalent to a 11.6 percent increase, and similar to the Utah growth rate of 12.6 percent<sup>1</sup>. This rapid population increase is expected to continue, driving demand for housing. The fastest growing demographic is the population over the age of 65, followed by young adults between the ages of 18 to 24;

---

<sup>1</sup> US Census Bureau 2010; ESRI 2017

- C. More homeownership and rental housing will be needed to accommodate future growth. Between 2010 and 2017, the number of family and non-family households expanded, although non-family households experienced a somewhat higher rate of increase. This pace is expected to continue, which means more homeownership and rental housing will be needed;
- D. Real estate prices have escalated across all residential product types. In 2017, the median sales price for a single-family home was \$325,000, \$352,000 for a townhouse, and \$275,000 for a condominium. Between 2014 and 2017, the median price increased by 30 percent for townhomes, and 42 percent for single-family homes and condominiums;
- E. Despite a high proportion of renter households (35 percent in Grand County<sup>2</sup>), there is a limited inventory of multifamily apartments. Higher density workforce housing products that could be more affordable to the workforce, such as apartments and condominiums, must compete with visitor accommodations, such as hotels and nightly rental units, for land. The economics of visitor accommodations allow them to pay more for land, making it difficult to build housing affordable to the workforce;
- F. The area's rapidly appreciating home prices has made housing out-of-reach for many working families. Housing costs have increased rapidly, substantially outpacing increases in household incomes. In general, no homes sold in 2017 were affordable to households earning up to 80 percent of Area Median Income, which is equivalent to a family of four earning \$54,150 annually. Households at 100 percent of median income (\$67,700 for a family of four) had limited homeownership options. Rental housing may be priced such that it is more within reach of moderate-income households, although there is a shortage of units available for rent.
- G. Tourism-related industries are the fastest growing employment sector in Grand County, accounting for approximately 43% of all employment<sup>3</sup>. Employment in accommodation and food services account for one out of every three jobs in Grand County. The next largest industries are retail and arts, entertainment, and recreation;
- H. Jobs in tourism-related industries tend to be relatively low-paying, with some positions offering only seasonal or part-time employment with limited wage growth. The 2017 median household income in Grand County (\$46,070) was lower than the statewide median of \$62,902<sup>4</sup>;
- I. Because affordable housing is in short supply within the Moab Area, lower-income households may be forced to live in less than adequate housing, pay a disproportionate share of their incomes to live in adequate housing, or commute ever-increasing

---

<sup>2</sup> Grand County Assured Housing Feasibility Study completed by BAE Urban Economics in 2018.

<sup>3</sup> Grand County Assured Housing Feasibility Study completed by BAE Urban Economics in 2018.

<sup>4</sup> The 2017 median household income data is taken from ESRI. This is different from the HUD Area Median Family Income (HAMFI), which is based on a four-person family household and was \$56,700 in 2017. The median household income described here accounts for all households of all different sizes, including non-family households.

distances to their jobs from housing located outside the Moab Area. These circumstances harm the County's ability to provide high levels of service, attain goals articulated in the General Plan, and preserve a high quality of life for residents;

- J. State and federal funds for the construction of new affordable housing are insufficient to fully address the current and projected shortages of affordable housing within the County. While the County has repeatedly amended its Land Use Code (LUC) to spur additional housing development, the private market has not provided adequate housing opportunities to extremely low-, very low-, low-, and moderate-income households;
- K. The HDH Overlay was developed over a two-year period that involved dozens of public meetings, workshops, open houses, and public hearings; Public input greatly informed the overlay regulations and map boundaries.

**WHEREAS**, the Planning Commission is statutorily responsible for making recommendations to the County Council regarding textual amendments to the LUC;

**WHEREAS**, the Grand County Planning Commission held a public hearing on September 25, 2018 to solicit public comment on a draft high density housing (HDH) overlay ordinance and recommended approval to the County Council; and,

**WHEREAS**, the Grand County Council held a public hearing on November 7, 2018 to solicit public comment on a draft assured housing ordinance and voted to approve said ordinance;

**NOW, THEREFORE BE IT RESOLVED**, Section 4.7 of the Grand County LUC shall read:

See attached Section 4.7 High Density Housing (HDH) Overlay Districts in Appendix A.

**PASSED, ADOPTED, AND APPROVED** by Grand County Council in a regular public meeting on January 15, 2019 by the following vote:

*Those voting aye:* \_\_\_\_\_

*Those voting nay:* \_\_\_\_\_

*Those absent:* \_\_\_\_\_

**ATTEST:**

**GRAND COUNTY COUNCIL**

\_\_\_\_\_

\_\_\_\_\_

Diana Carroll, Clerk\Auditor

Evan Clapper, Chair





## Appendix A

### Section 4.7 High Density Housing (HDH) Overlay Districts

#### Article 4.7

### HIGH DENSITY HOUSING (HDH) OVERLAY DISTRICT

#### Sections:

- 4.7.1 Purpose.
- 4.7.2 Applicability.
- 4.7.3 Definitions.
- 4.7.4 Uses permitted with a development agreement.
- 4.7.5 Development incentives.
- 4.7.6 Assurance of primary residential occupancy.
- 4.7.7 Special Needs Emergency/Transitional Housing.
- 4.7.8 Pre-application procedure.
- 4.7.9 Application – Development plans and map required.
- 4.7.10 Findings.
- 4.7.11 Effect of High Density Housing Overlay approval.
- 4.7.12 Periodic Review of High Density Housing Ordinance.
- 4.7.13 Expiration of High Density Housing Ordinance
- 4.7.14 Enforcement.

#### **4.7.1 Purpose.**

---

A. Grand County has established a High Density Housing Overlay (HDHO) district to facilitate the provision of new housing units used for primary residential occupancy by actively employed households. The HDHO districts (See Map- Exhibit A) are intended to provide the opportunity and means for the County to meet its estimate of additional residential and workforce housing needs, to achieve the goals of the housing element of the County's General Plan, and to implement the policies and goals of the housing element of the County's General Plan.

B. These regulations are intended to encourage the development of new housing units by assisting both the public and private sector in making the provision of these units economically viable, while providing assurances to the County that these units will maintain a high degree of quality and will remain financially accessible to residents and local area workers.

C. These regulations are further intended to encourage the provision of primary residential housing through the combination of the HDHO districts with multiple-family and single-family residential zoning districts within the County where the residential housing projects are determined to be feasible and are consistent with the County's General Plan.

D. The HDHO is intended to:

1. Provide a means of directing and simplifying the process for creating and maintaining primary residential housing.

2. Provide a means of directing and simplifying the process for creating and maintaining affordable housing constructed to meet the Assured Housing requirements of Section 6.15.

3. Provide incentives to developers, whether in new or rehabilitated housing, to maintain primary residential rental and ownership units in perpetuity.

#### **4.7.2 Applicability.**

---

The regulations set forth in this Article may be applied to specific sites meeting the following criteria:

A. The site is located in one of the High Density Housing (HDHO) districts;

#### **4.7.3 Definitions.**

---

A. "Active Employment" or "Actively Employed" means a household with at least one person who meets one of the following criteria:

(1) A full-time (aggregate of 30 hours of employment per week) employee of an entity or entities located within Grand County Boundaries; or

(2) An owner or owner's representative of a business or entity with a primary place of business within Grand County Boundaries; or

(3) A full-time (aggregate of 30 hours of employment per week) worker who is self-employed or work out of their home must provide their entire list of clients/workload so

that it can be verified that a minimum of 75% of their work/clients are based within Grand County Boundaries; or

(4) A person who is unable to work or does not have a work history required under subsections (1) through (3) above due to a Disability.

(5) Where there are unrelated individuals living together in one household, at least fifty percent (50%) of all the adults comprising the household shall meet the Active Employment requirement of this section.

B. "High Density Housing Overlay (HDHO) district" means a zoning district with its attendant increased density that applies in addition to an existing zoning designation where the County encourages the provision of new housing units used for primary residential occupancy as further described in this Article.

C. "High Density Housing Overlay (HDHO) development" means a subdivision or site plan that exists within an HDHO (overlay) district and complies with the regulations of this section.

D. "High Density Housing Overlay (HDHO) unit" is a dwelling unit that is deed restricted to meet the requirements of this section of the Land Use Code.

E. "Household" means one (1) person living alone, two (2) or more individuals related to each other by blood, marriage, or another legally recognized relationship, or a maximum of five (5) unrelated individuals residing in the same residence.

F. "Primary resident" means a household that meets the "Primary residential occupancy" requirement. (See Paragraph G. Below)

G. "Primary residential housing" or "Primary residential development" shall have the same meaning as "High density housing development."

H. "Primary residential occupancy" means the owner of record occupies the dwelling unit for a minimum of nine (9) months out of any twelve (12) month period or a renter occupies the

dwelling unit through a lease term no shorter than six (6) months out of any twelve (12) month period.

I. “Special needs/transitional housing” means temporary housing that is made available to certain segments of the local population who face significant challenges in finding and retaining permanent housing. Special needs may include homelessness, substance abuse, domestic violence, or other similar needs.

#### **4.7.4 Uses permitted with a development agreement.**

---

The following uses are permitted with the execution of a development agreement by the County and the developer.

A. Residential developments at a density greater than normally permitted by the underlying zoning district as described in the table below, when the development provides a substantial level of housing units intended for primary residential occupancy by actively employed households. A substantial level is defined herein as a minimum of eighty percent (80%) of the units in the development being deed restricted to primary residential and actively employed residents. Deed restricted units (HDHO units) may be owner-occupied or renter-occupied as long as the residents meet the requirements for primary residency and active employment. The maximum density (units/acre) limit shall be based on a calculation that includes all existing and all new units on the land area that is being included in the calculation. Residential development qualifying for greater density pursuant to the provisions of this ordinance shall be permitted to obtain such density by constructing residential housing types not otherwise allowed in the underlying zoning district. For example, multi-family units may be constructed in a single-family residential zone.

High Density Housing (HDH) District	Maximum Density
HDH 35a	35 units per acre
HDH 35b	35 units per acre
HDH 25	25 units per acre
HDH 15	15 units per acre
HDH 10	10 units per acre

HDH 5	5 units per acre
-------	------------------

B. Accessory uses or structures incidental to the principally permitted use pursuant to Section 3.3 of this Land Use Code. Any accessory dwelling unit permitted under Section 3.3 in an HDHO Development shall meet the occupancy and active employment requirements of subsection A of this Section.

#### **4.7.5 Development incentives.**

---

A. General. In order to reduce costs associated with the development and construction of primary residential housing, the property development standards set forth in subsection C of this section are established for the HDHO districts. These property development standards represent a relaxation of standards normally applied to development in the County and are established in order to facilitate and promote the development of primary residential housing in the County and shall be extended upon issuance of a site plan or preliminary plat approval. As a further inducement to the development of primary residential housing beyond the relaxation and flexibility of development standards, the County, where appropriate, may also extend one or more of the development incentives set forth in subsection D, the selection of which shall depend on the quality, size, nature, and scope of the development being proposed. Incentives shall be targeted to improve the development design or to yield the greatest number of HDHO units, so as to permit the County to meet its estimate of additional housing needs and the goals of the housing element of the County's general plan. It is also the intent of the County to facilitate primary residential housing by encouraging developer involvement with the Moab Area Housing Task Force, Community Reinvestment Agencies, and other public and private entities concerned with the provision of primary residential housing and by cooperating with such entities.

B. Eligibility. Eligibility for the property development standards set forth in subsection C of this section requires the developer to propose a housing development containing at least eighty percent (80%) primary restricted residential units occupied by actively employed households.

C. Property Development Standards. The following development standards shall apply to HDHO units in the HDHO districts.

1. General Design Standards. The development shall be designed and developed in a manner compatible with and complementary to existing and potential development in the immediate vicinity of the development site. Site planning on the perimeter shall provide for protection of the property from adverse surrounding influences and shall protect surrounding areas from potentially adverse influences from the property. To the greatest extent possible, the design of the development shall promote privacy for residents and neighbors, security, and use of passive solar heating and cooling through proper placement of walls, windows, and landscaping.

2. Minimum Design Standards. Minimum design standards are included to ensure a high degree of quality in the development of HDHO units. Unless modified by the County Council, the following design standards shall apply to a development that utilizes the density increases allowed by this Article.

a. Sidewalks shall be installed along all street frontages where otherwise required by this LUC.

b. Screening Requirements

i. Outdoor Storage Screening. All outdoor storage areas for materials, trash, mechanical equipment, vehicles, or other similar items shall follow the standards outlined in Section 6.4.3.

ii. Parking Lot Screening. Parking lot screening must be provided between those portions of an off-street parking area containing six (6) or more parking spaces and a different zoning district or a public street and shall be designed according to the following:

a. Parking lot screening must be provided within ten feet (10') of the perimeter of the parking lot to be screened, except for parking lots adjacent to rain gardens/bio-retention systems, other landscape features, or where screening may negatively impact the traffic sight distance (as defined by the American Association of State Highway and Transportation Officials (AASHTO) and verified by the County Engineer)

- b. Parking lot screening shall be not less than eighty percent (80%) opaque and be a minimum of three feet (3') in height as measured from the highest finished adjacent grade of the parking area. When shrubs are used to provide the screen, such shrubs must be at least two feet (2') tall at planting and anticipated to grow to at least three feet (3') tall at maturity.
- c. No landscaping or screening shall interfere with driver or pedestrian visibility for vehicles entering or exiting the premises.
- d. Screening for a parking lot may be comprised of plants found in Section 6.4.3.F.
- e. Content: Parking lot screening must consist of at least two (2) of the following:
  - i. A compact hedge of evergreen or densely twigged deciduous shrubs spaced to ensure closure into a solid hedge at maturity;
  - ii. A berm with plantings as described above;
  - iii. Transit shelters, benches, bicycle racks, and similar features may be integrated as a part of the screen;
  - iv. Fencing may be integrated as part of the screen. All wood fencing shall be stained and sealed with a weatherproof product.
- iii. Parking Island Design. Off-street parking areas with at least twenty-five (25) parking stalls shall contain interior landscaped islands. Such islands shall be bounded by a raised concrete curb, pervious curbing, or an approved equivalent and shall contain mulch to retain soil moisture. This provision shall

not apply to parking structures. The standards for landscaped islands are as follows:

- a. Landscaped parking lot islands shall be required at the beginning and end of each parking row and shall contain a minimum of one hundred eighty (180) square feet and a minimum width of nine feet (9').
  - b. A minimum of one tree shall be provided for each island.
  - c. Shrubs, perennials or ornamental grass shall be incorporated in each landscaped island that does not contain a tree.
  - d. Islands shall be prepared with topsoil to a depth of two feet (2') and improved to ensure adequate drainage, nutrient, and moisture retention levels for the establishment of plantings.
  - e. All perimeter and interior landscaped areas in parking lots shall be equipped with an irrigation system adequate for establishing and maintaining the plant materials within it.
- c. Building Exterior Façade Standards.
- i. Exterior finishes may be of wood, masonry, stone, stucco, HDO board or other high quality material permitted by the building code, but shall not utilize vinyl siding; cedar or wood shakes; highly reflective, shiny, or mirror-like materials; or exposed plywood or particle board.
  - ii. Buildings shall utilize at least two (2) of the following design features to provide visual relief along the front of the residence:
    - a. Projections, recessions, or reveals such as, but not limited to, columns, pilasters, cornices, and bay windows
    - b. Dormers.
    - c. Gables.
    - d. Recessed entries, a minimum of three (3) feet deep.



- e. Covered front porches.
- f. Cupolas.
- g. Architectural Pillars or Posts.
- h. Quoins.
- i. Corbeling on wall.
- j. Decorative lintel.
- k. Incorporation of brick or stone on at least 25% of front surface area

iii. Planning staff shall have the authority to waive this requirement when the building is not visible from adjacent properties or the public right-of-way.

- d. Where HDHO units may be placed on the same lot as current or future temporary or short-term accommodations, dedicated HDHO units shall be clustered together so as to minimize the exposure of residents to temporary guests. In all other developments, where temporary or short-term accommodations units do not exist and cannot exist due to zoning restrictions, dedicated HDHO units shall be dispersed throughout the residential development.
- e. Where there is a combination of commercial and residential uses, the commercial uses shall front along the highest road designation. Residential development shall be located behind commercial development or on upper floors above commercial development.
- f. The County Council may waive, or modify, any, or all, of these requirements when the Council finds it is infeasible to comply due to physical or other constraints on the lot.

3. Minimum Building Site Area and Lot Width. There shall be no minimum building site area, minimum lot width, or maximum lot coverage requirements for individual lots or individual dwelling sites in a HDHO district development. However, the building site area lot widths, and lot coverage percentages shall be designated on a site plan pursuant to Section 9.17 or preliminary plat pursuant to Section 9.4 approved by the Planning Commission.

4. Density. Overall density of site development within an HDHO district shall not exceed the limits established in Section 6.14.040.

## 5. Building Height.

- a. Maximum building heights shall not exceed the limits defined in the underlying zone district except that buildings constructed in the HDHO 35b district shall not exceed four (4) stories or forty-two (42) feet in height.
- b. To the maximum extent possible, building heights and locations shall minimize shading and interruption of solar access to adjacent properties with existing residential structures or commercial agricultural operations.
- c. All structures shall conform to the Ridgeline Standards of Section 6.9.8.
- d. Structures built under the HDHO must comply with the setback and buffer requirements of the underlying zone. The maximum height of the building at the exterior wall shall be the greater of:
  - i. 20 feet
  - ii. The building's setback at that point
- e. From the exterior wall, the building's height may increase to its maximum height at a rate not greater than a 45° angle from the maximum allowable height of the exterior wall.

## Examples of HDH Height-Compliant Structures

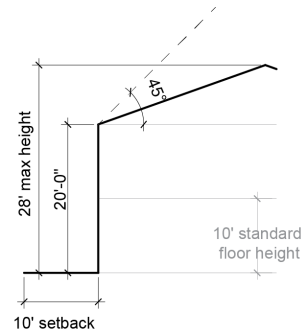
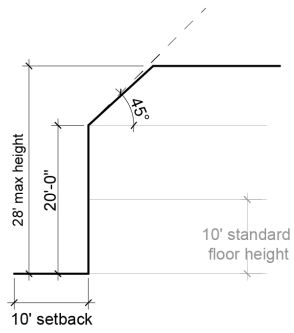

28' Max. Height Examples

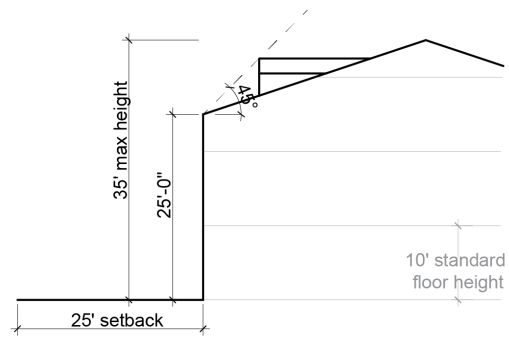
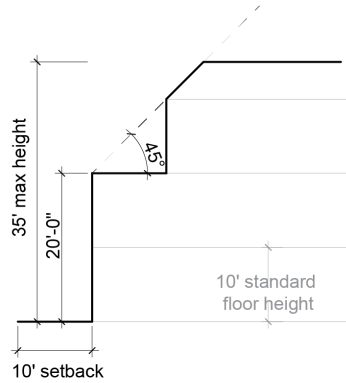

35' Max. Height Examples

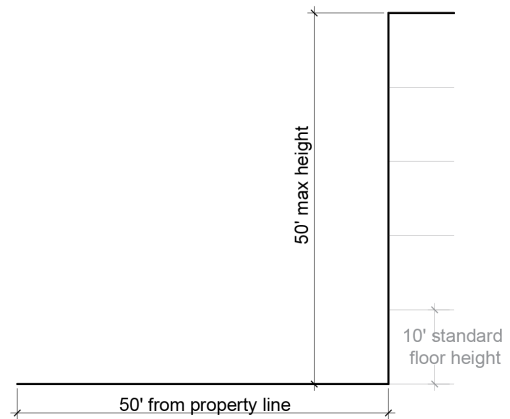
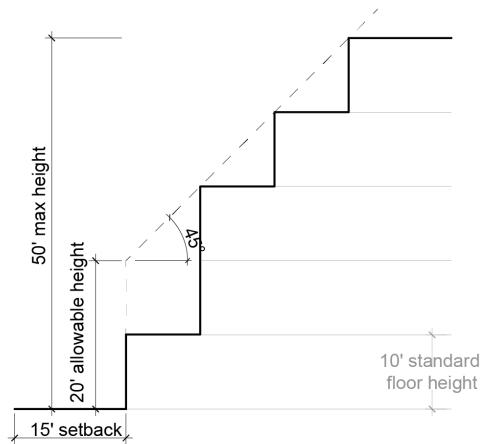

50' Max. Height Examples

6. Setbacks. The minimum setbacks from the lot line of the development shall be determined by the buffer requirements of Section 5.4.1.B and the compatibility standards of Section 6.10.

7. Parking.

i. Number of spaces required

a. For every single-family or two-family dwelling, there shall be provided at least two (2) off-street parking spaces for each unit. Parking spaces provided in a garage or carport may count towards the minimum requirement.

b. For every attached multifamily dwelling, off-street parking spaces shall be provided in accordance with Section 6.1.4:

Multi-family dwellings	Efficiency and one-bedroom	1.5 per dwelling unit
	Two-bedroom	1.75 per dwelling unit
	Three-bedroom and Larger	2.0 per dwelling unit

ii. Parking design requirements

c. Parking areas for single-family or two-family dwellings need not be paved.

d. Parking areas for attached multifamily dwellings shall be subject to the off-street requirements outlined in Section 6.1.7.

e. Uncovered surface parking may be permitted in the rear and side setbacks but is not permitted in the front or street-side setback.

f. Garages, carports, and individual locking storage units are subject to the setback standards outlined in Section 5.4.1.

- g. Required spaces for multifamily developments equal to or greater than five units shall be covered in a carport or a garage except that for multifamily dwellings with four or fewer units, parking spaces can be uncovered.

8. Minimum Standards of Physical Condition. A HDHO unit is required to have and maintain those minimum standards of physical conditions set forth in Exhibit B - Minimum Standards.

9. Streets. All public streets within or abutting the proposed planned development shall be dedicated and improved to County specifications for the particular classification of street; all private streets shall meet fire code and access standards.

10. Signs. Signs shall be permitted only to the extent allowed under Section 6.5, Signs, and must be approved by the Planning and Zoning Administrator.

11. Construction Timing. The HDHO units shall be ready for occupancy no later than the date of the initial or temporary occupancy of any unrestricted units within the development or applicable phase thereof. If the unrestricted units are developed in phases, then the HDHO units may be developed in proportion to the phasing of the unrestricted units. For example, in an approved development that includes 100 units built in two 50-unit phases the first phase must include at least 40 HDHO units.

D. Additional Development Incentives. In addition to the relaxed and flexible development standards set forth in subsection C of this section, the County may offer other development incentives should the County Council determine that such incentives are warranted and in the best interest of the County. For example, the County may offer exceptions, waivers or modifications of other development standards that would otherwise inhibit density and achievement of affordable housing goals for the development site, including, but not limited to, placement of public works improvements. The County may also offer impact fee waivers, property tax abatements, or direct financial contributions.

#### **4.7.6 Assurance of primary residency and occupancy.**

---

HDHO units developed under this Article shall remain available to persons and families who live and work in Grand County according to the standards set forth in Section 6.14.030 in perpetuity. The developer shall be required to enter into a development agreement with the County to ensure primary residential occupancy by actively employed households is maintained prior to recordation of final plat or issuance of a building permit for the applicable development. Each housing unit designated for primary restricted residential occupancy by an actively employed household (an HDHO unit) shall also include a deed restriction attached to its title in accordance with the standards set forth in this section. Grand County reserves the right to revoke, deny or suspend any permit, including a land development permit, conditional use permit, building permit, certificate of occupancy, or discretionary approval if the standards of this section are not met.

#### **4.7.7 Special Needs Emergency/Transitional Housing.**

---

Pursuant to the applicable County codes, a developer may, at the sole discretion of the County and subject to certain requirements, satisfy a portion of its primary residential housing requirements by provisioning special needs/transitional housing units through either direct construction, land donation or the donation of existing units. There must be a quantified, demonstrated need for the emergency/transitional housing within the Grand County boundaries. The housing must be developed in collaboration with a federally recognized, 501(c)(3) nonprofit organization. The housing must satisfy all requirements of the applicable local, state and federal requirements. Given the unique and varying characteristics of the population to be served, the rents for special needs/transitional housing must be approved in advance by the County Council or its designee.

#### **4.7.8 Pre-application procedure.**

Prior to submitting an application for an HDHO district development, the applicant or prospective developer should hold preliminary consultations with the Community and Economic Development Director and other County staff as may be desirable, to obtain information and guidance before entering into binding commitments or incurring substantial expense in the preparation of plans, surveys and other data. Such preliminary consultations should include information on potential federal, state, and local affordable housing funding availability, and

program requirements in guaranteeing the development's consistency with the objectives of this overlay district.

#### **4.7.9 Application – Development plans and map required.**

---

An application for an HDHO district development must be for a parcel or parcels of land that is under the control of the person, corporation, or entity proposing the development. The application shall meet all requirements of and include all submission materials required in connection with an application for preliminary plat or site plan approval and shall be submitted with the County's standard application form. In addition to the foregoing, the application shall include the following:

- A. The proposed means for assuring the continuing existence, maintenance and operation of the development as a primary residential housing project; and
- B. Such other information as may be required by the Community and Economic Development Director to allow for a complete analysis and appraisal of the planned development.

#### **4.7.10 Findings.**

---

In approving a development with respect to which the high density housing district zone is applicable, the County Council, upon the recommendation of the Planning Commission, shall make the following findings to ensure that the application is appropriate to the purpose and the location:

- A. The concessions granted for density and deviation from design standards, are commensurate with the level of primary residential occupancy provided by the development. Specifically, the greater the extent of concessions and incentives, the greater the level of primary residential occupancy.
  - B. The developer enters into a development agreement to maintain the occupancy and employment restrictions of the development specific to the requirements of the County and any funding sources with greater or longer occupancy requirements.
-

#### **4.7.11 Effect of High Density Housing Overlay approval.**

##### **A. Not Approval of Final Plat**

Approval of plans submitted in conjunction with an application for the High Density Housing Overlay shall not constitute approval of the final plat. Rather, it shall be deemed an expression of approval to the layout submitted on the preliminary plat as a guide to the preparation of the final plat, compliance with all requirements of Section 4.7, and the development agreement required under Section 4.7.6.

##### **B. Lapse of Approval**

The High Density Housing Overlay regulations codified herein for a development project within an HDHO district shall be valid for a period of 24 months from the date of approval and the general terms and conditions under which the approval was granted will not be changed. The HDH Overlay approval shall be deemed voided unless a final plat approval is granted within the 24-month period or unless the 24-month period is extended by the County Council at the request of the developer.

#### **4.7.12 Expiration of High Density Housing Ordinance.**

---

This ordinance shall automatically expire after 300 HDHO units have received certificates of occupancy or after two years, whichever occurs first. A record of the number and location of HDHO units in receipt of certificates of occupancy shall be kept on file within the Community and Economic Development Department at all times.

#### **4.7.13 Enforcement.**

---

A. It shall be a misdemeanor to violate any provision of this Article. Without limiting the generality of the foregoing, it shall also be a misdemeanor for any person to sell or rent to another person a HDHO unit under this Article who does not meet the residency and occupancy requirements of this Article or to sell or rent a HDHO unit to a household not qualified under this



Article. It shall further be a misdemeanor for any person to provide false or materially incomplete information to the County or its designee or to a seller or lessor of a HDHO unit to obtain occupancy of housing for which the person is not eligible.

B. The County may institute any appropriate legal actions or proceedings necessary to ensure compliance with this Article, including: (i) actions to revoke, deny or suspend any permit, including a land development permit, conditional use permit, building permit, certificate of occupancy, or discretionary approval; (ii) actions to recover from any violator of this Article civil fines, restitution to prevent unjust enrichment from a violation of this Article, and/or enforcement costs, including attorney fees; (iii) eviction or foreclosure; and (iv) any other appropriate action for injunctive relief or damages. Failure of any official or agency to fulfill the requirements of this Article shall not excuse any person, owner, household or other party from the requirements of this Article.

Exhibit A to HDH District

High Density Housing Overlay Boundaries

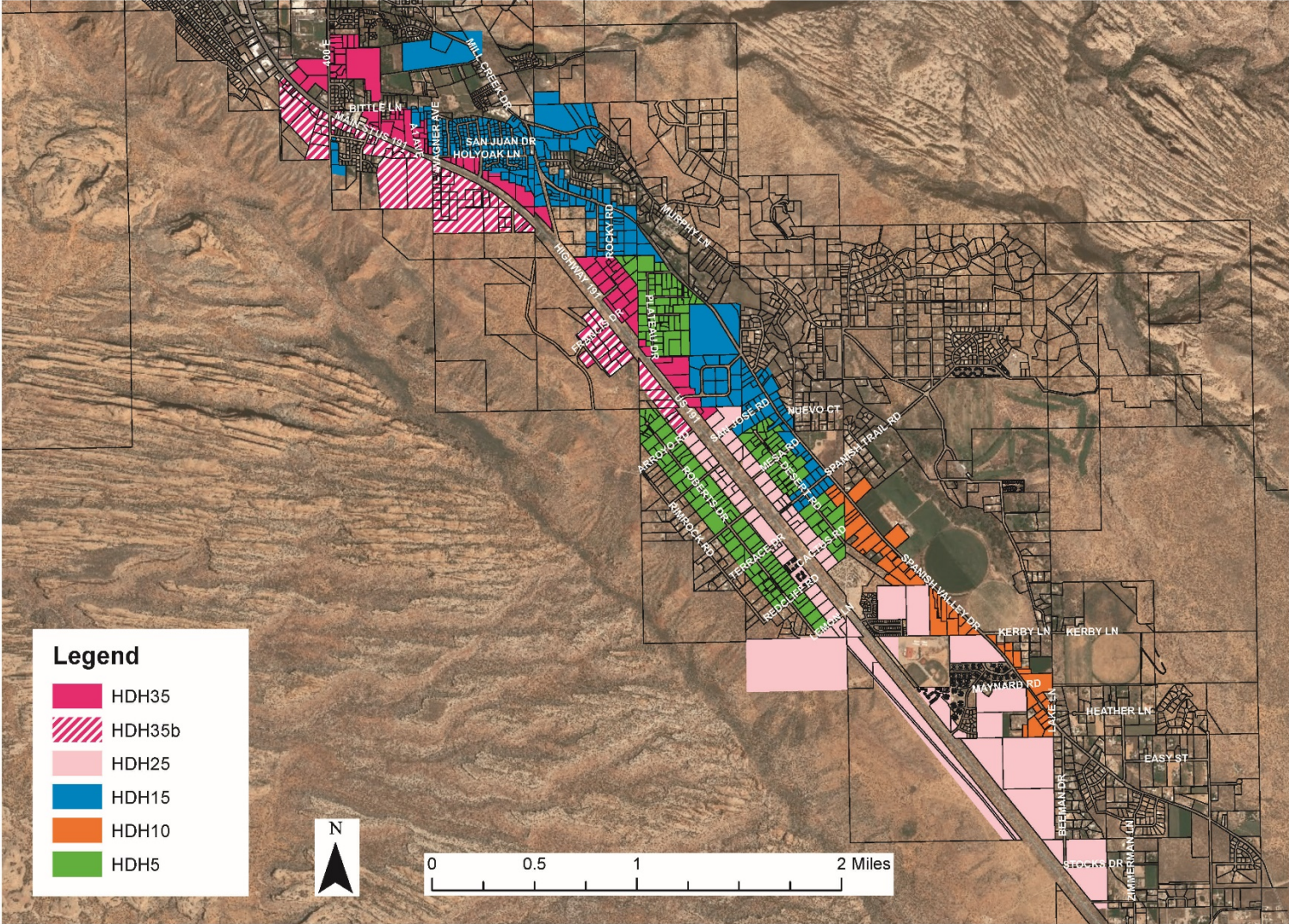

## Exhibit B to HDH District

### Minimum Standards for Physical Conditions of High Density Housing Overlay (HDHO) Units

- Clean unit
- Carpets steam-cleaned two or three days prior to closing
- All scratches, holes, burned marks repaired in hardwood floors, linoleum, tile, and counter tops, etc.
- No broken or foggy windows
- All screens in windows (if screens were originally provided)
- All doors will be in working order with no holes
- All locks on doors will work
- All keys will be provided; e.g., door, mail box, garage
- All mechanical systems shall be in working order
- Walls paint ready
- Normal wear and tear on carpet; if carpet has holes, stains, etc., the carpet and padding shall be replaced or escrow funds at current market value per square foot for a comparable product shall be held at the time of closing to be used by the new buyer
- No leaks from plumbing fixtures
- Any safety hazard remedied prior to closing
- Satisfaction of radon issue if found at time of inspection
- All light fixtures shall be in working order
- All appliances that existed in the original Unit, remain and are in good working order and good condition

#### DEFINITIONS

- Clean Unit: All rooms will be cleaned as stated below:
- Kitchen:
  - Range - Inner and outer surfaces will be cleaned.
  - Range hood and Exhaust Fan
  - Refrigerator and Freezer - Inner and outer surfaces of refrigerator and freezer will be clean. Freezer will be defrosted.
  - Cabinets and Countertops - Exterior and interior surfaces of cabinets and drawers will be clean. Door and drawer handles, if provided, shall be clean and in place.

- Sink and Garbage Disposal - Sink and plumbing fixtures will be clean. Garbage disposal must be in working order.
- Dishwasher - Must be in working order and inner and outer surfaces shall be clean.
- Blinds, Windows, Screens:
  - Mini-blinds, Venetian Blinds, Vertical Blinds, and Pull Shades - Will be clean.
  - Windows - All window surfaces, inside and outside of the window glass, shall be clean.
  - Screens - Screens will be clean and in place with no holes or tears.
- Closets: Closets, including floors, walls, hanger rod, shelves and doors, shall be clean.
- Light Fixtures: Light fixtures will be clean and shall have functioning bulbs/florescent tubes.
- Bathrooms:
  - Bathtub, Shower Walls, Sinks - Bathtubs, shower walls and sinks shall be clean.
  - Toilet and Water Closet - Water closets, toilet bowls and toilet seats will be clean. If the toilet seat is broken or peeling, the seat shall be replaced.
  - Tile - All tile and grout will be clean.
  - Mirrors and Medicine Cabinets - Mirrors and medicine cabinets shall be cleaned inside and out.
  - Shelves and/or Other Cabinetry - All other shelving or cabinetry shall be cleaned inside and out.
- Walls, Ceilings, Painted Doors and Baseboards: Painted surfaces must be cleaned with care to ensure the surface is clean without damaging the paint.
- Floors: Floor cleaning includes sweeping and mopping and could include stripping, waxing and buffing. Types of floor surfaces include bamboo and marmoleum.
- Interior Storage/Utility Rooms: Storage/utility rooms shall be cleaned. Properly cleaned storage/utility rooms will be free from odors, removable stains, grease marks or accumulations.
- Washer/Dryer- Must be in working order and inner and outer surfaces shall be clean
- Safety Hazard: Any item that provides a safety hazard shall be fixed. This would include, but is not limited to, exposed electrical wiring, satisfaction of any radon issue found, ventilation for gas hot water system, etc.
- Walls Paint-Ready: All holes shall be patched; all posters, pictures, etc., shall be removed from all walls; all nails, tacks, tape, etc., shall be removed from all walls; and all walls shall be clean and ready for the new buyer to paint. If wallpaper has been placed on the wall and in good condition, the wallpaper can remain; if the wallpaper is peeling off, the wallpaper must be removed.
- Windows: If a window is broken, including the locking mechanism, the window shall be replaced. If the window has a fog residue in the inside, it shall be replaced.

**DRAFT**  
**Grand County Planning Commission**

January 8, 2019

A regular meeting of the Grand County Planning Commission convened on the above date at the Grand County Courthouse, 125 E. Center St., Moab, UT 84532

**Members Present:** Chair Gerrish Willis, Robert O'Brien, Christine "Cricket" Green, Kevin Walker, Abby Scott, Emily Campbell, and Rachel Nelson

**Members Absent:**

**Staff Present:** Zacharia Levine and Kenny Gordon

**Council Liaison:** Terry Morse

Meeting was called to order at 5:30 pm by Chair Gerrish Willis.

**Citizens to be heard:** None.

Electing/Appointing the Chair and Vice-Chair Emily Campbell moves to nominates Abby Scott for Chair. Cricket Green moves to nominate Garrish Willis for Chair. Abby Scott seconds nomination for Garrish Willis for Chair. Kevin Walker seconds nomination for Abby Scott as Chair. Abby express apprehension to being Chair because she knows she will be missing some meetings. Vote (via paper ballot): 3 votes for Abby Scott, 4 votes for Garrish Willis. Garrish Willis is Chair. Kevin Walker moves to nominates Abby Scott for Vice Chair. Cricket Green seconds nomination for Abby Scott for Vice Chair. All were unanimous, vote carries. Abby Scott is Vice Chair.

Proposed lighting ordinance, which updates Section 6.5.5(D) Sign Illumination and 6.6 Outdoor Lighting.

Staff has collaborated with the ad-hoc Dark Skies Working Group to create a draft outdoor lighting ordinance. We have consulted the Executive Director of the International Dark Skies Association (IDA), members of the Colorado Plateau Dark Skies Initiative, professional outdoor lighting designers in the Mountain West, public officials from Flagstaff, AZ, which is often touted as having *the* model outdoor lighting code, Ketchum, ID, and Horseshoe Bay, TX, as well as local stakeholders from the outdoor guide community, federal, and state land management agencies. The draft outdoor lighting ordinance presented to planning commission draws from the best available information, model lighting policies from around the western US, and feedback from the abovementioned representatives.

Staff reiterates the importance of minimizing light pollution for the purposes of Grand County residents' enjoyment of dark skies, meeting sustainability and energy efficiency goals, preserving and enhancing astrotourism as an economic driver, limiting detrimental public health impacts, and supporting ecosystem health (i.e. flora and fauna depend on dark night skies).

Chair Gerrish Willis opens the floor to public comment. Joette Langianese express support for the outdoor lighting changes. Sharon Russell express support for the outdoor lighting changes. With no other comments, Garrish Willis closes public comment period.

Kevin Walker moves to forward a favorable recommendation to Grand County Council amending Section 2.11.4 (Resort Commercial District) and Section 6.5.5(D) Permitted Sign Illumination and Section 6.6 – Outdoor Lighting. Seconded by Bob O'Brien. For 6, against 1 (Cricket Green), vote carries.

(See revised Outdoor Lighting and Sign Illumination Standards)

**Approval of Minutes:** December 17, 2018: Motion to approve the December 17, 2018 meeting minutes with corrections, For 6, against 0, abstained 1 (Garrish Willis was not present). The December 17, 2018 were approved.

**Future Considerations:**

**Community Development Department Update:** None.

**County Council Liaison report::** None.

**Adjournment:** Motion to adjourn meeting, all were unanimous. Adjourned at 7:30 pm.