



## ORDINANCE NO. 26-008

### AN ORDINANCE REVISING THE BRIAN HEAD STANDARD SPECIFICATIONS FOR PUBLIC WORKS CONSTRUCTION MANUAL AND PROVIDING FOR AN EFFECTIVE DATE.

**WHEREAS**, the Brian Head Town Council adopted Ordinance No. 07-011 establishing the Brian Head Standard Specifications for Public Works Construction Manual Public Works Standards for Construction on September 11, 2007 which established certain standards for plans and specifications for construction within the Town boundaries; and

**WHEREAS**, The Brian Head Public Works Director has determined an amendment to the Public Works Standards to ensure they are up to date with industry and engineering standards, and;

**WHEREAS**, the Brian Head Town Council has determined that it is in the best interest of the public health, safety, and welfare of Brian Head Town that the Standard Specifications for Public Works Construction Manual be revised.

**NOW THEREFORE, BE IT ORDAINED BY THE BRIAN HEAD TOWN COUNCIL OF IRON COUNTY, UTAH AS FOLLOWS:**

**SECTION 1.** The Brian Head Town Standard Specifications for Public Works Construction be revised, see Attachment "A"

**SECTION 2. Effective Date.** Upon this Ordinance being adopted by the Brian Head Town Council of Iron County, Utah, all provisions of this ordinance shall be incorporated. All provisions of the Brian Head Public Works Standards for Construction Manual that are inconsistent with the express terms of this ordinance shall be repealed. All other provisions of the Brian Head Public Works Standards for Construction Manual shall remain in full force.

**SECTION 3. Conflict.** To the extent of any conflict between other Town, County, State, or Federal ordinances or regulations, and this ordinance, the more restrictive is deemed to be controlling.

**SECTION 4. Severability Clause.** If any section, subsection, sentence, clause, phrase, or portion of this ordinance is for any reason, held invalid or unconstitutional by any court or competent jurisdiction, such portions shall be deemed a separate, distinct and independent provision, and such holding shall not affect the validity of the remaining portions of this ordinance.

**PASSED AND ADOPTED BY THE BRIAN HEAD TOWN COUNCIL OF IRON COUNTY, UTAH this 12<sup>th</sup> day of May 2026, with the following vote:**

Mayor Clayton Calloway	Yes
Council Member Larry Freeberg	Yes
Council Member Duane Nyen	Yes
Council Member Logan Cruz	Yes
Council Member Martin Tidwell	Yes

**BRIAN HEAD TOWN**

By:   
Clayton Calloway, Mayor

**ATTEST:**

  
Nancy Leigh, Town Clerk



**CERTIFICATE OF PASSAGE AND POSTING**

I hereby certify that the above Ordinance is a true and accurate copy, including all attachments, of the Ordinance passed by the Town Council on the 28<sup>th</sup> day of April 2026, and have posted a copy of the ordinance on the Public Meeting Notice Website and on the Town website: [brianheadtown.utah.gov](http://brianheadtown.utah.gov) as per UCA 63-30-102.

*Nancy Leigh, Town Clerk*

Brian Head Town

# PUBLIC WORKS STANDARDS

Manual of Standard Specifications  
for Public Works Construction



Adopted  
**May**  
**2026**

# CONTENTS

## TABLE OF CONTENTS

Chapter 1 – General Requirements.....	1
1.1 Introduction.....	1
1.2 Terms & Definitions .....	1
1.3 Permit, Fee & Bonding Requirements .....	2
1.4 Pre-Construction Approvals .....	3
1.5 Safety .....	4
1.6 Inspections.....	4
1.7 Testing.....	5
1.8 As-Built Drawings .....	5
1.9 Damage to Existing Utilities.....	5
1.10 Dust/Debris Control & Cleanup.....	5
1.11 Standard Drawings .....	6
Chapter 2 – Earthwork .....	7
2.1 Excavation .....	7
2.2 Earth Fill .....	7
Chapter 3 – Excavation & Backfill for Trenches .....	9
3.1 Trench Excavation & Safety .....	9
3.2 Trench Backfill & Bedding .....	9
3.3 Roadway Surface Cuts & Replacement.....	11
Chapter 4 – Water Lines & Service Connections.....	13
4.1 Materials .....	13
4.2 Pipe Installation .....	14
4.3 Disinfection & Testing .....	15
Chapter 5 – Sanitary Sewer, Storm Drain Lines & Laterals.....	17
5.1 Materials .....	17
5.2 Pipe Installation .....	19
5.3 Field Testing.....	21
Chapter 6 – Concrete Curb, Gutter & Sidewalk .....	24
6.1 Materials .....	24



# CONTENTS

6.2 Installation.....	24
Chapter 7 – Asphalt Paving & Granular Base Course.....	27
7.1 Materials.....	27
7.2 Installation.....	28
Chapter 8 – Portland Cement Concrete.....	30
8.1 Materials.....	30
8.2 Concrete Mix Design.....	32
8.3 Placing Concrete.....	33
Chapter 9 – Work Site Traffic Control.....	39
9.1 General Requirements.....	39
Appendix A – Standard Drawings.....	41



# GENERAL REQUIREMENTS

## 1.1 INTRODUCTION

### 1.1.1 Purpose

The purpose of these Construction Standards and Specifications is to govern any work performed or improvements installed within Public rights-of-way of the Town of Brian Head (Town). Developers and/or contractors should thoroughly read and understand these Construction Standards and Specifications before designing and constructing public improvements.

### 1.1.2 Scope

The contractor shall contact Public Works/Engineering at Brian Head Town Hall for all matters dealing with construction work within Town rights-of-way or with any work connecting onto a Town utility. Special permits and bonding are required for all such work. The contractor shall also conform to all applicable ordinances adopted by the Town and contained in the Town Codes of Brian Head Utah, latest edition, and subsequent amendments or appeals.

These Construction Standards and Specifications are the minimum requirements of the Town. In the event that any provision herein conflicts with the Brian Head Town Code, other requirements specified by the Town, or with generally accepted standards for Public Works construction, the more stringent of the standards shall apply.

## 1.2 TERMS AND DEFINITIONS

### 1.2.1 Definition of the term "Town"

The term "Town", as used herein, refers to The Town of Brian Head, Utah, and its personnel or duly authorized agents.

### 1.2.2 Definition of the term "Code"

The term "Code", as used herein, refers to the Town Codes of Brian Head Utah, a test edition, and subsequent amendments thereto.

### 1.2.3 Definition of the term "Standards"

The term "Standards", as used herein, refers to these Construction Standards and Specifications.

### 1.2.4 Standard Acronyms

- 1) IBC: International Building Code
- 2) IPC: International Plumbing Code
- 3) IFC: International Fire Code
- 4) ASTM: American Society for Testing and Materials
- 5) AWWA: American Water Works Association



## GENERAL REQUIREMENTS

- 6) AASHTO: American Association of State Highway and Transportation Officials
- 7) ANSI: American National Standards Institute
- 8) OSHA: Occupational Safety and Health Administration
- 9) ACI: American Concrete Institute

### 1.2.5 Standard Abbreviations

- 1) DI: Ductile Iron
- 2) DIP: Ductile Iron Pipe
- 3) PVC: Polyvinyl Chloride
- 4) PVCP: Polyvinyl Chloride Pipe
- 5) CP: Non-reinforced Concrete Pipe
- 6) RCP: Reinforced Concrete Pipe
- 7) HDPE: High Density Polyethylene
- 8) IPS: Iron Pipe Size
- 9) psi: Pounds per Square-inch
- 10) mg/l: Milligrams per Liter
- 11) F: Fahrenheit
- 12) fps: Feet per Second
- 13) cu ft: Cubic Feet

### 1.3 PERMIT, FEE AND BONDING REQUIREMENTS

#### 1.3.1 Building Permit

It shall be unlawful to perform any construction, excavation work on any street, curb, gutter, sidewalk, sewer line, water line, storm drain line, or other infrastructure addition or improvement in the Town without an approved building, grading and trenching, or right-of-way permit as defined by the Code.

Absolutely no work shall be started until a properly executed permit is secured. In a case where a contract to perform work for the Town has been executed, the contract shall fulfill the permit requirement.

In addition to the requirements of the Code, all applications for permits shall include the following:

- 1) The anticipated start and completion dates of the project.
- 2) The exact address or location of the work.
- 3) A description of the work.
- 4) A request, which shall be made at least 72 hours prior to beginning construction, to identify and locate.

The contractor shall perform all work in accordance with the terms of the building permit and the Standards in effect on or before the date of the permit. All work shall be done in a



## GENERAL REQUIREMENTS

timely manner and within set time limits, which may be a condition of the permit and can be shortened because of safety concerns. Building permits can be suspended if a contractor fails to comply with the Standards and Code.

The developer is responsible for their entire development until all construction is completed and accepted by the Town.

### 1.3.2 Fees

Before a permit is issued, a permit fee and an inspection fee shall be paid to the Town. Permit and inspection fees shall be established by Town Council resolution in the Consolidated Fee Schedule. Fees shall be assessed on the following items or conditions:

- 1) Sewer, Water, and Storm Drain Lateral Installation and Inspection.
- 2) All re-inspections that are required after an inspection have been requested and performed, but the work, or a portion thereof is found to be defective or incomplete.
- 3) Barricades (provided by, or required by, the Town).

### 1.3.3 Bonds

All public improvement projects shall have a financial guarantee for performance, pursuant to the Code, which shall be in the form of bonds or cash deposits. Each contractor doing work in the Town is required to maintain a bond with the Town. The amount of the bond will be set in the Town fee schedule. This bond is to guarantee the following:

- 1) Construction work is completed.
- 2) Final inspection is conducted.
- 3) The construction of, and repairs to and/or replacement of, public improvements are finished and accepted.

A surety shall issue bonds or, if desired, a cash bond can be paid directly to the Town. The Town shall approve all bonds and no bond shall be released until all improvements are completed and accepted by the Town.

## 1.4 PRE-CONSTRUCTION APPROVALS

### 1.4.1 Town Approval of the Contractor

The Town shall approve all contractors before any work is performed. This approval is granted for a period of one (1) year upon submission of the following:

- 1) A current Utah State Contractor's License. Work will be restricted to that authorized by the license.



## GENERAL REQUIREMENTS

- 2) Proof of comprehensive general liability insurance, with the Town named as additionally insured. Combined liability insurance will be in an amount of not less than one million dollars (\$1,000,000.00) for any one occurrence.
- 3) A five-thousand-dollar (\$5,000.00) cash bond, paid to the Town, that will be in effect for a period of one (1) year after the completion of all work performed by the contractor.

### 1.4.2 Town Approval of the Construction Plans

The Town, before the commencement of construction, shall approve all construction plans and cut sheets.

The contractor, before the commencement of construction, shall hold a pre-construction meeting with the Town, all utility companies affected by the work, and all contractors involved with the work.

## 1.5 SAFETY

No contractor shall leave any work in an unsafe condition. All persons working on any street, sidewalk, sewer line, water line, storm drain line, etc. shall comply with all applicable federal, state, and local safety regulations including OSHA regulations for work in confined spaces and trenches.

## 1.6 INSPECTIONS

### 1.6.1 Mandatory Inspections

All work covered by a permit shall be inspected by the Town prior to the following:

- 1) The commencement of backfilling and compacting operations.
- 2) The placing of concrete and asphalt surfacing.
- 3) The installation of any underground piping.
- 4) Any connection to a Town utility line.
- 5) Any other work done in a public right of way.

Town Inspectors shall also be notified before beginning construction for any Public Works project.

### 1.6.2 Notification Requirements

Prior notifications for inspections by the Town are required as follows:

- 1) Inspections performed during regular working hours require at least twenty-four (24) hours prior notification.
- 2) Inspections needed after 4:00 p.m. require notification by 1:00 p.m. on the day prior to the inspection.



## GENERAL REQUIREMENTS

3) Inspections needed on the weekend require that notification be given by 1:00 p.m. on the proceeding Thursday.

### 1.7 TESTING

The developer/contractor is responsible for all testing required under these standards. Failure to perform sufficient tests shall be justification to delay acceptance of the work until such tests are completed by the developer/contractor.

### 1.8 AS-BUILT DRAWINGS

The Town requires that as-built drawings for each separate development be submitted by the developer/contractor before the construction of curb, gutter, and sidewalk or installation of asphalt. Measurements should be referenced from a permanent fixture such as a fire hydrant, manhole, or survey monument located on the outside boundaries of the lots. The outside property line may be used if a permanent fixture is not available. Measurements and utilities should be clearly labeled on the as-built drawings. Utilize similar types of measurements on any valves or manholes located in the street or on the development. Measurements should also show lateral connections to main lines. All As-built drawings must be submitted as full-size drawings and in GIS format.

### 1.9 DAMAGE TO EXISTING UTILITIES

#### 1.9.1 Developer/Contractor Responsibilities

The developer/contractor shall notify all utility companies and have them locate and mark their respective utilities prior to any construction.

The developer/contractor shall notify all appropriate utility companies of their intent to begin construction. The developer/contractor shall be liable for all damage to properties that are damaged by themselves, their agents, and their employees.

### 1.10 DUST/DEBRIS CONTROL AND CLEANUP

#### 1.10.1 Dust/Debris Control

The developer/contractor shall be responsible for controlling dust and debris created by its construction operations or originating from the construction site at all times. All rights-of-way shall be cleaned of dirt and mud daily to allow safe passage of vehicles and pedestrians.

#### 1.10.2 Cleanup of Construction Sites

The developer/contractor shall clean up its construction site and, where applicable, restore the site its original condition. All materials shall be removed, gravel surfaces replaced, sod



## GENERAL REQUIREMENTS

areas restored, asphalt replaced, and all other work necessary to leave the area in at least its preexisting condition must be completed before final approval will be issued by the Town.

### 1.10.3 Revegetation of Disturbed Areas

Disturbed areas in the Town right of way must be revegetated with native seed mix approved by Brian Head Town. Where seed is likely to blow or wash away, hydroseed should be employed. Any slope of 2:1 or steeper with a vertical height of 10 feet or more requires a heavy-duty, long-lasting germination and erosion control blankets rated for up to 3 years. Straw mats can be used on slopes of 3:1 or 4:1 with a vertical height of 20 feet or more.

## 1.11 STANDARD DRAWINGS

### 1.11.1 Incorporation of Standard Drawings

All of the standard drawings included in the Appendix of these standards are hereby incorporated as official construction standards of Brian Head Town Public Works. Departure from these standard drawings may only be granted by written consent of the Town where compliance with the standard drawings is deemed infeasible and alternative plans have been accepted by the Town and approved by the Town Engineer.



# EARTHWORK

## 2.1 EXCAVATION

### 2.1.1 Blasting

Blasting shall be permitted only by written approval and as directed by the Town. All blasting activities shall comply with Utah Office of Administrative Rules R614, and any other applicable state and federal regulations. Developers shall provide a plan to the Town illustrating that they will take all reasonable steps to restore the area after blasting activities are completed.

### 2.1.2 Use of Excavated Materials

Suitable materials from the excavations may be used for constructing permanent earth or rock fill embankment. The suitability of materials for specific purposes shall be determined by the Town upon review by a geotechnical engineer. The contractor must properly dispose of all surplus or unsuitable excavated materials.

### 2.1.3 Slope Safety

All slope construction shall be in accordance with all Town, State, and Federal regulations. No permanent slopes steeper than two (2) horizontal to one (1) vertical shall be allowed without a retaining structure. Permanent retaining structures must comply with §9-12-11 of the Town code.

### 2.1.4 Excavation Limits

Excavation shall be completed to the lines and grades established by the design engineer and approved by the Town. Excavation beyond specified lines and grades shall be filled and compacted in accordance with these Standards. All borrow areas shall be graded and finished to eliminate steep or unstable side slopes or other hazardous or unsightly conditions. Excavation limits shall be minimized to protect natural vegetation and environment.

## 2.2 EARTH FILL

### 2.2.1 Placement

- 1) Fill materials shall not be placed until the required excavation and foundation preparations have been completed and approved by the Town. Fill shall not be placed upon or against any frozen surface, nor shall snow, ice, or frozen material be incorporated into the fill.
- 2) The subgrade for earth fills shall be graded to remove surface irregularities and shall be scarified parallel to the axis of the fill or otherwise scored and loosened to a minimum depth of four (4) inches. The moisture content of the scarified subgrade shall



## EARTHWORK

be controlled as specified herein and the surface materials of the foundation shall be compacted and bonded with the first layer of earth fill.

3) Fill materials shall meet the gradation and composition requirements of these standards and shall be free of large rocks, excessive organic material, asphalt, or any other deleterious material. Fill material that does not conform to these Standards shall be reworked or removed and replaced with acceptable material.

4) Earth fill placed in street rights-of-way, parking areas, or foundations shall be compacted to a minimum of ninety-five (95) percent of maximum density as determined by AASHTO T-180.

5) Adjacent to structures, fill shall be placed in a manner that will prevent damage to the structures and will allow the structures to gradually receive loads from the backfill. The height of fill adjacent to structures shall be increased at the same rate on all sides of the structure.

### 2.2.2 Controlling Moisture Content

1) During placement and compaction operations the moisture content of the fill and backfill materials shall be maintained in conformance with AASHTO T-180, Method C.

2) Disking, blading, or other approved methods shall be used to obtain uniform moisture distribution prior to compaction. Excessively wet materials shall be either removed or brought to acceptable moisture content prior to compaction.

3) If the surface of a previously placed and compacted layer of fill becomes dry and unsuitable to receive a successive layer; the surface shall be scarified and moistened to an acceptable moisture content prior to the placement of additional fill.



# EXCAVATION & BACKFILL FOR TRENCHES

## 3.1 TRENCH EXCAVATION AND SAFETY

### 3.1.1 Trench Safety

- 1) All construction shall be performed in accordance with the provisions and regulations of the Utah State Industrial Commission and the OSHA. Trenches shall not be left open at any time unless guarded with adequate barricades, warning lights, and signs.
- 2) When required, excavations shall be braced and shored to support the walls of the excavation to eliminate sliding and settling and as may be required to protect the workers, the work in progress, and existing utilities and improvements. All such support devices shall comply with the requirements of the applicable regulations.
- 3) Any injury or damage resulting from a lack of adequate trench design or support shall be the responsibility of the developer/contractor. The developer/contractor shall, at its own expense, affect all necessary repairs or reconstruction resulting from such damage.

### 3.1.2 Dewatering

Any water that collects in the excavation during the performance of the work shall be removed. Any "quick" conditions that occur to the soil in the trench shall be remedied before construction proceeds.

## 3.2 TRENCH BACKFILL AND BEDDING

### 3.2.1 General

The Town shall approve all backfill material. Under no circumstances shall rocks of a size larger than allowed under this Standard be permitted in the backfill material surrounding any pipe. When sand or gravel is used for backfill above the pipe zone, it must be pre-approved by the Town.

Sand or gravel should be well-graded and free from slag or pea gravel unless otherwise approved by the Town.

### 3.2.2 Pipe Zone Backfill for Concrete, Ductile Iron, and Steel Pipe

- 1) Pipe zone bedding and backfill for concrete, ductile iron, and steel pipe shall not contain rocks with a maximum diameter larger than three-quarter inches (3/4" minus). Backfill above the pipe zone shall not contain rocks with a diameter larger than eight (8) inches.
- 2) Backfill shall be placed under and around the pipe in horizontal layers not to exceed six (6) inches and tamped by hand or pneumatic tampers up to the lower one-sixth (1/6) of the outside diameter of the pipe. The thickness of bedding under the pipe shall be at least four (4) inches.



3) The pipe zone shall extend at least twelve (12) inches above the top of the pipe. Pipe zone bedding and backfill shall be compacted to at least ninety-five (95) percent of the maximum density as determined by ASTM D 1557, or seventy (70) percent of the relative density for cohesion less soils as determined by ASTM D4254, whichever is applicable.

### **3.2.3 Pipe Zone Backfill for Corrugated Steel, Polyvinyl Chloride and Polyethylene Pipe**

- 1) Pipe zone bedding and backfill for corrugated steel, polyvinyl chloride, and polyethylene pipe shall not contain rocks with a maximum diameter larger than three-quarter inches (3/4" minus). Backfill above the pipe zone shall not contain rocks with a diameter larger than eight (8) inches.
- 2) Backfill shall be placed under and around the pipe in horizontal layers not to exceed six (6) inches and tamped by hand or pneumatic tampers up to the lower one-sixth (1/6) of the outside diameter of the pipe. The thickness of bedding under the pipe shall be at least four (4) inches.
- 3) The pipe zone shall extend at least twelve (12) inches above the top of the pipe. Pipe zone bedding and backfill shall be compacted to at least ninety-five (95) percent of the maximum density as determined by ASTM D1557, or seventy (70) percent of the relative density for cohesion less soils as determined by ASTM D4254, whichever is applicable.

### **3.2.4 Pipe Bedding on Rock or Hard Foundations**

In no case shall pipe be installed directly on bedrock, hard clay, shale, or rocks with a maximum diameter larger than two (2) inches. Where such foundations are encountered, the contractor shall over-excavate below the pipe grade and place at least four (4) inches of bedding material below the pipe.

### **3.2.5 Backfill above the Pipe Zone in Roadways or Parking Areas**

Backfill shall be placed in horizontal layers not exceeding eight (8) inches in thickness and then compacted to at least ninety-five (95) percent of the maximum density as determined by ASTM D1557. The backfill shall be placed at or near its optimum moisture content. The backfill thickness placement requirement may be made less stringent depending on the method of compaction employed by the contractor. The Town must approve adjustments to the backfill thickness requirement.

### **3.2.6 Backfill Outside of Roadways and Parking Area**

Backfill shall be placed in horizontal layers not exceeding twelve (12) inches in thickness and then compacted to at least eighty-five (85) percent of the maximum density as determined by ASTM D698. The backfill shall be placed at or near its optimum moisture content. The backfill thickness placement requirement may be made less stringent depending on the method of compaction employed by the contractor. The Town must approve adjustments to the backfill thickness requirement.



### 3.3 ROADWAY EXCAVATION SURFACE CUTS & REPLACEMENT

#### 3.3.1 Cutting of Asphalt Pavement

When the excavation is made in a paved street, the asphalt surface shall be cut on each side of the trench to provide a vertical joint in the surface. The asphalt must be saw cut unless otherwise approved by the Town. No asphalt shall be cut or excavated unless replacement asphalt is available. This may be determined by the time of the year. Except in the case of an emergency which shall be determined by the Public Works Director. In case of an emergency contractor shall still maintain surface until replacement asphalt is available.

#### 3.3.2 Asphalt Surface Restoration

- 1) The contractor shall perform all work and furnish all materials to restore any asphalt surface damaged or disturbed by its construction operation. Pavement restoration shall follow, as closely as possible, the installation and backfilling of pipe. The contractor shall be responsible for maintaining the road surface in sufficient condition to allow travel by the public at all times until the surface is restored.
- 2) The asphalt surface shall be saw cut on each side of the trench prior to excavation. Granular base course and asphalt shall conform to these Standards. Edges shall also be cut straight and vertical prior to the placement of asphalt if they have become irregular or damaged during pipe installation and backfill.
- 3) A temporary granular base course shall be placed flush with the existing asphalt surface and maintained in a good condition until the pavement is restored. This base course shall be excavated to the bottom of the existing pavement prior to restoring the surface. An asphalt tack coat shall be placed on the edges of the cut asphalt, and new asphalt placed and compacted with a five-ton minimum steel- wheeled roller or other approved method to attain at least ninety-five (95) percent of maximum laboratory density. The asphalt shall be placed in such a manner that the finish surface is flush with the existing surface and provides a smooth riding surface. The finished asphalt shall be at least three (3) inches thick, or as thick as the existing asphalt, whichever is greater. Cold weather asphalt restoration shall comply with Section 7.2.3(3).

#### 3.3.3 Gravel Road Surface Restoration

- 1) The contractor shall perform all work and furnish all materials to restore any gravel road surface damaged or disturbed by its construction operation. Surface restoration shall follow, as closely as possible, the installation and backfilling of pipe. The contractor shall be responsible for maintaining the road surface in sufficient condition to allow travel by the public at all times until the surface is restored.
- 2) The contractor shall restore the surface of gravel roads with four inches (4") of a granular base course meeting the following specifications and compacted to at least ninety-five (95) percent of maximum laboratory density:



## EXCAVATION & BACKFILL FOR TRENCHES

Sieve Size	Percent Passing (AASHTO T27 and T11)
1"	100
3/4"	97-100
1/2"	-
3/8"	70-80 (6)
No.4	51-63 (7)
No.16	28-39 (6)
No.40	19-27 (5)
No.200	10.0-16.0 (4)

( ) Value in parenthesis is the allowable deviation (+/-) from the target values. If the plasticity index (PI) is greater than 0, the target value range for No.200 sieve size is 8-12 (4).



## 4.1 MATERIALS

### 4.1.1 Water Line Materials

Materials for constructing water lines shall be limited to the following:

- 1) Ductile Iron Pipe, pressure class or special thickness class, conforming to ANSI/AWWA C150/A21.50 and C151/A21.51. All DIP shall be cement mortar lined in conformance with AWWA C104 and have a factory-applied coating of coal tar enamel.
- 2) Joints and fittings shall be push-on bell and spigot type conforming to ASNI/AWWA C111/A21.11; mechanical joint type conforming to ANSI/AWWA C111/A21.11; or flanged type conforming to ANSI/AWWA C110/A21.10. All DI fittings shall be protected with polyethylene encasement, at least 8 mils thick, conforming to ANSI/AWWA C105/A21.5. All DI fittings shall be cement mortar lined in conformance with AWWA C104 and have a factory applied coating of coal tar enamel.
- 3) All gate valves shall be resilient seated wedge type gate valves conforming to AWWA C509 and suitable for buried service. The valves shall be equipped with a 2" square operating nut, and furnished with a slip type valve box and all required mounting hardware.
- 4) All butterfly valves shall conform to AWWA C504 Class 150B suitable for buried service. The valves shall be equipped with a 2" square operating nut, and furnished with a slip type valve box and all required mounting hardware.
- 5) All fire hydrants shall conform to AWWA C502 and shall be equipped with a five and one-quarter valve opening, two hose nozzles, one pumper nozzle, and have appurtenant valve, box, fittings, and concrete footing and thrust block. Fire hydrants shall be "Traffic" type with a replaceable break-away section immediately above finish grade. All fire hydrants shall be of the "dry barrel" type and suitable for use in climates subject to freezing. Hydrant specifications shall be consistent with standard drawing 405, or as otherwise approved by the Public Works Director.
- 6) Thrust Blocking shall be installed at all applicable locations to prevent the pipe from moving due to hydrostatic and hydrodynamic forces. Thrust blocks shall be constructed of concrete placed to bear against undisturbed soil. Fittings and bolts shall be covered with polyethylene to prevent their encasement in concrete. The use of mechanical thrust restraining systems, whether in conjunction with thrust blocks or separately, must be approved by the Town.

### 4.1.2 Water Service Materials

Materials for constructing water services shall be limited to the following:

- 1) Laterals shall be either "Type K" copper tubing or IPS HDPE pressure rated to 250 psi or higher and with a Standard Dimension Ratio (SDR) of 7. Use the same diameter and material as the existing service lateral when extending a lateral. Water service lines larger than two (2) inches shall be approved by the Town on a case-by-case basis.



## WATER LINES & SERVICE CONNECTIONS

- 2) Saddles shall be of epoxy coated stainless steel double band saddles or brass construction and shall have two "U" bolts or a wide band with two bolts on each side of the saddle. The rubber gasket shall conform to the outside diameter of the main water line.
- 3) Corporation stops shall be the same size as the service lateral and shall be suitable for use with copper or HDPE service laterals, whichever is applicable.
- 4) Meter setter assemblies shall have a State approved double check valve backflow prevention device. Town will provide and install water meter that meets Town standards and is compatible with Town meter reading system. The cost of meters will be according to the Town fee schedule.
- 5) Meter boxes shall have a diameter of eighteen (18) inches and a depth of seven (7) feet and shall be constructed from either concrete or HDPE.
- 6) All meter boxes shall be equipped with a cast iron ring, foam insulations and lid and set to grade.

### 4.2 INSTALLATION

#### 4.2.1 Care, Handling, and Inspection

- 1) Special care shall be taken to prevent damage to pipe and protective coatings. Proper equipment, tools and facilities shall be provided and used for safe and controlled construction procedures. Pipe placed in trenches shall be lowered in place by means of ropes, booms or any type of power equipment sufficient to handle each piece separately. In no case shall pipe be allowed to fall freely. Pipe will not be allowed to be stored in the flow line of any gutter.
- 2) All foreign matter or dirt shall be removed from the inside of the pipe before it is placed and it shall be kept clean during and after laying. Should the pipe become dirty, contaminated or flooded with trench water, it shall be cleaned in accordance with methods specified in the latest edition of AWWA C651 prior to disinfection and installation.
- 3) All pipes shall be carefully inspected by the contractor/developer prior to installation and defective pipe shall not be used.

#### 4.2.2 Installation

- 1) Installation methods shall conform to the requirements of the latest edition of AWWA C600 and best current practices. The type of bedding required shall be specified by the design, the Town, or as detailed on the plans. Under no circumstances will any pipe be laid until inspection is complete and selected samples have adequately passed the requirements of the applicable Specifications. All pipes shall be laid true to line and grade. Cut sheets and grade stakes shall be supplied to the Town for approval.
- 2) Pipe shall be laid with the bell end upstream with relation to flow. A slight excavation for the bell at the joints shall maintain a suitable foundation for the barrel of



## WATER LINES & SERVICE CONNECTIONS

the pipe. Maximum deflection shall not exceed manufacturer recommendations. Pipe shall have a minimum cover of seven (7) feet to a maximum cover of eight (8) feet below finish grade unless otherwise approved in writing by the Town. Installation shall conform to the requirements of the applicable AWWA standards or manufacturer's recommendations whichever is most stringent.

- 3) All openings in a pipeline shall be closed with watertight or rodent-proof plugs when installation is stopped at the close of work or when work is stopped for other reasons. If the trench becomes flooded, watertight plugs shall be installed, and remain in place, until the trench is dewatered.
- 4) All rubber-gasket joints shall be completed in accordance with installation instructions supplied by the manufacturers of the pipe. All joints to be deflected shall be laid straight and then deflected after the joint is complete. In no case shall the deflection exceed five (5) degrees. Backfill may or may not be completed prior to placing the next section of pipe at the option of the developer/contractor, but subsequent adjustment or damage to joints shall require the pipe section to be removed, cleaned and reinstalled.
- 5) All pipelines shall be marked with locator tape placed at the top of the pipe zone (12 inches above the top of pipe). Metallic locator tape shall be used for all non-metallic pipeline installations. Locator wire shall be installed directly on top of the pipe and running up all hydrants and valves.
- 6) Installation of all pipes, hydrants, meters, valves and other culinary water appurtenances shall comply with standard drawings 102, 115, 401, 402, 403, 404, 405, 406, and 407 contained in the Appendix of these Standards.

### 4.3 DISINFECTION AND TESTING

#### 4.3.1 Field Hydrostatic Testing of Water Lines

1) The section of line to be tested shall be isolated and slowly filled with water. Air should be expelled from the line through hydrants or taps made at the high points. The pipe shall be tested at two-hundred (200) psi or higher as determined by the Town and shall be maintained at this pressure for at least two (2) hours using either pneumatic or hydraulic means. Accurate means shall be provided for measuring the quantity of water required to maintain the test pressure. This volume of water shall not exceed:

$$Q = NDP / (7400^{1.12})$$

Where:

Q = maximum allowable leakage, gallons per hour

N = number of joints in the test length

D = diameter of pipe, inches

P = test pressure, psi

2) All damaged or defective pipe or fittings shall be replaced and any known leaks shall be repaired prior to field hydrostatic testing.



## 4.3.2 Disinfection of Water Lines

- 1) Disinfection of water lines shall be performed in accordance with AWWA C651. The pipe shall be clean prior to disinfection. If, in the opinion of the Town, contamination in the pipe is such that it cannot be removed by flushing, the pipe shall be cleaned by mechanical means and then swabbed with a one (1) percent hypochlorite disinfecting solution. All new lines shall be isolated from existing lines during the disinfection and testing process.
- 2) The Tablet Method, as described in AWWA C651 shall consist of placing calcium hypochlorite tablets at the specified rate in the water line during construction at the upstream end of each section of pipe.
- 3) The tablet shall be attached with an adhesive, such as Permatex No. 1. The line shall then be filled slowly to expel all air, and maintained full for at least twenty four (24) hours, or forty eight (48) hours when the water temperature is less than forty-one (41) degrees F. The disinfection solution shall contain at least thirty (30) mg/l of available chlorine after these periods.
- 4) If the Continuous Feed Method, as described in AWWA C651, is used; the disinfecting solution shall contain at least twenty-five (25) mg/l of available chlorine after twenty-four (24) hours.
- 5) No contractor will be allowed to flush the line until a chlorine residual test has been passed and accepted by the Town.

## 4.3.3 Flushing and Sampling of Water Lines

- 1) After disinfection is complete, the water line shall be thoroughly flushed with clean water and, if necessary, re-chlorinated until satisfactory bacteriologic tests are obtained. Flow velocities of at least two and one-half (2.5) fps must be maintained throughout the flushing process. If any test fails, the contractor shall be responsible for the fees incurred for additional testing.
- 2) Bacteria samples shall be obtained at the sites designated by the Town for each job. There shall be a minimum of one sample obtained for waterlines up to two-hundred (200) feet in length and a minimum of two samples obtained for waterlines between two-hundred (200) and six-hundred (600) feet in length. For water lines longer than six-hundred (600) feet in length, at least one sample shall be obtained for every six-hundred (600) feet.
- 3) The line will be flushed and re-tested if any sample point fails on the first test. The line will be completely re-disinfected and re-tested at all sample points if any sample point fails a second time. In addition, the line will be re-disinfected and re-tested at all sample points if any returned sample is marked "presence", indicating the existence of coliform bacteria.
- 4) Water services will not be installed until the Town has approved all bacteria sample results.



# SANITARY SEWER, STORM DRAIN LINES & LATERALS

## 5.1 MATERIALS

### 5.1.1 Sanitary Sewer Line Materials

Materials for constructing sanitary sewer lines shall be limited to the following:

- 1) Ductile Iron Pipe, pressure class or special thickness class, conforming to ANSI/AWWA C150/A21.50 and C151/A21.51. All DIP shall be protected with polyethylene encasement, at least 8 mils thick, conforming to ANSI/AWWA C105/A21.50 having a minimum thickness of 8 mils. All DIP shall be cement mortar lined in conformance with AWWA C104 and have a factory-applied coating of coal tar enamel.
- 2) Polyvinyl Chloride Pipe conforming to ASTM 3034 with a Standard Dimension Ratio (SDR) of 35 or less. PVCP having an installation depth greater than twelve (12) feet shall require special approval by the Town.
- 3) Polyethylene Pipe conforming to ASTM F405 and ASTM F667.
- 4) All joints shall be completed in accordance with the requirements and recommendations of the pipe manufacturer.
- 5) Manhole sections shall be of precast reinforced concrete. Manhole covers and frames shall be cast in accordance with ASTM A48, Class 35, and shall be free from blow-holes and shrinkage defects. The minimum weight of the frame shall be two hundred eighty (280) pounds and the minimum weight of the cover shall be one hundred sixty (160) pounds.
- 6) Bases for manholes shall be precast concrete manufactured according to the dimensions on the drawings. All manholes shall have at least a forty (40)-inch channel between the inlet and outlet pipes. The entire surface of the manhole invert, including channels and shelves, shall be made dense and smoothed with a steel trowel. All inverts shall follow the grades of the pipe entering the manholes unless there is a change of direction greater than ten (10) degrees; in which case there shall be a drop of at least one-tenth (0.1) foot between the inlet and outlet pipes. When there is a change in direction of ninety (90) degrees there shall be a drop of two-tenths (0.2) foot between the inlet and outlet pipes. When a smaller pipe joins a larger one, the invert of the larger pipe should be lowered sufficiently to maintain the same energy gradient. Precast manhole bases shall include all materials necessary for a complete installation, including rubber boots. In no case shall an incoming line be allowed to drop more than twelve (12) inches to the base. A drop manhole connection shall be used if the elevation difference is greater than twelve (12) inches.
- 7) Where pressurized sewer systems are allowed by the Town, all materials utilized will comply with manufacturer specifications and will be approved in advance by the Town Engineer and Public Works Director.

### 5.1.2 Sanitary Sewer Lateral Materials



## SANITARY SEWER, STORM DRAIN LINES & LATERALS

Materials for constructing sanitary sewer laterals shall be limited to the following:

- 1) Ductile Iron Pipe, pressure class or special thickness class, conforming to ANSI/AWWA C150/A21.50 and C151/A21.51. All DIP shall be protected with polyethylene encasement, at least eight (8) mils thick, conforming to ANSI/AWWA C105/A21.50 having a minimum thickness of eight (8) mils. All DIP shall be cement mortar lined in conformance with AWWA C104 and have a factory-applied coating of coal tar enamel.
- 2) Polyvinyl Chloride Pipe conforming to ASTM 3034 with a Standard Dimension Ratio (SDR) of 35 or less. PVC having an installation depth greater than twelve (12) feet shall require special approval by the Town.
- 3) Polyethylene Pipe conforming to ASTM F405 and ASTM F667.
- 4) All joints shall be completed in accordance with the requirements and recommendations of the pipe manufacturer.
- 5) Sanitary sewer lateral clean-out stand pipes shall be cast iron or ABS with a cast iron or brass cap.
- 6) Where pressurized sewer systems are allowed by the Town, all materials utilized will comply with manufacturer specifications and will be approved in advance by the Town Engineer and Public Works Director.

### 5.1.3 Storm Drain Line Materials

Materials for constructing storm drain lines shall be limited to the following:

- 1) Ductile Iron Pipe, pressure class or special thickness class, conforming to ANSI/AWWA C150/A21.50 and C151/A21.51. All DIP shall be protected with polyethylene encasement, at least 8 mils thick, conforming to ANSI/AWWA C105/A21.50 having a minimum thickness of 8 mils. All DIP shall be cement mortar lined in conformance with AWWA C104 and have a factory-applied coating of coal tar enamel.
- 2) Polyvinyl Chloride Pipe conforming to ASTM 3034 with a Standard Dimension Ratio (SDR) of 35 or less. PVC having an installation depth greater than twelve (12) feet shall require special approval by the Town.
- 3) Polyethylene Pipe conforming to ASTM F405 and ASTM F667.
- 4) Non-reinforced Concrete Pipe conforming to ASTM C14 providing it meets the strength requirements for the particular application.
- 5) Reinforced Concrete Pipe conforming to ASTM C76.
- 6) All joints shall be completed in accordance with the requirements and recommendations of the pipe manufacturer.
- 7) Manhole sections shall be of precast reinforced concrete. Manhole covers and frames shall be cast in accordance with ASTM A48, Class 35, and shall be free from blow-holes and shrinkage defects. The minimum weight of the frame shall be two



# SANITARY SEWER, STORM DRAIN LINES & LATERALS

hundred eighty (280) pounds and the minimum weight of the cover shall be one hundred sixty (160) pounds.

8) Bases for manholes shall be precast concrete manufactured according to the dimensions on the drawings. All manholes shall have at least a forty (40) inch channel between the inlet and outlet pipes. The entire surface of the manhole invert, including channels and shelves, shall be made dense and smooth with a steel trowel. All inverts shall be adjusted such that the crowns of all incoming pipes is equal and there is at least a five-hundredths (0.05) foot drop between the crowns of the inlet pipes and the crown of the outlet pipe. All precast manhole bases shall include all materials necessary for a complete installation, including rubber boots.

9) Catch basins shall meet the requirements as shown in the Standard Drawings section of these Standards.

## 5.2 PIPE INSTALLATION

### 5.2.1 Care, Handling, and Inspection

1) Special care shall be taken to prevent damage to pipe and protective coatings. Proper equipment, tools and facilities shall be provided and used for safe and controlled construction procedures. Pipe placed in trenches shall be lowered in place by means of ropes, booms or any type of power equipment sufficient to handle each piece separately. In no case shall pipe be allowed to fall freely. Pipe will not be allowed to be stored in the flow line of any gutter.

2) All foreign matter or dirt shall be removed from the inside of the pipe before it is placed and it shall be kept clean during and after laying.

3) All pipes shall be carefully inspected by the contractor/developer prior to installation and defective pipe shall not be used.

### 5.2.2 Installation

1) Installation methods shall conform to the requirements of the manufacturer. The type of bedding required shall be specified by the design, the Town, or as detailed on the plans. Under no circumstances will any pipe be laid until inspection is complete and selected samples have adequately passed the requirements of the applicable specification. All pipes shall be laid true to line and grade. Cut sheets or grade stakes shall be supplied to the Town for approval.

2) A slight excavation for the bell at the joints shall maintain a suitable foundation for the barrel of the pipe. Maximum deflection shall not exceed manufacturer recommendations but in no case shall it exceed five (5) percent. The bedding condition for concrete pipe shall conform to at least a Class C condition.

3) All openings in a pipeline shall be closed with watertight or rodent-proof plugs when installation is stopped at the close of work or when work is stopped for other



# SANITARY SEWER, STORM DRAIN LINES & LATERALS

reasons. If the trench becomes flooded, watertight plugs shall be installed, and remain in place, until the trench is dewatered.

- 4) All rubber-gasket joints shall be completed in accordance with installation instructions supplied by the manufacturers of the pipe. Backfill may or may not be completed prior to placing the next section of pipe at the option of the developer/contractor, but subsequent adjustment or damage to joints shall require the pipe section to be removed and reinstalled.
- 5) All pipelines shall be marked with locator tape placed at the top of the pipe zone. Metallic locator tape shall be used for all non-metallic pipeline installations. Locator wire shall be installed directly on top of the pipe and running up all manholes and stand pipes.
- 6) Installation of all sanitary sewer pipes, manholes, sewer service connections, storm sewer conveyance, catch basins, and other sanitary and storm sewer appurtenances shall comply with standard drawings 204, 206, 207, 300, 301, 302, 303, 304, 305, 306 and 307 contained in the Appendix of these Standards.

## 5.2.3 Minimum Size and Slope Requirements

- 1) In no case shall the diameter of any sanitary sewer line be less than eight (8) inches. In no case shall the diameter of any storm drain line be less than fifteen (15) inches.
- 2) The minimum slopes for sanitary sewers and storm drain lines are as follows:

Pipe Size (in)	Slope (%)
4	2.00
6	0.80
8	0.50
10	0.40
12	0.35
15	0.30
18	0.25
21	0.20
24	0.15

- 3) Whenever possible, the slope should exceed 0.006 ft/ft. The pipe should be sized to meet anticipated hydraulic loads. Increasing the pipe size to reduce the minimum slope requirement shall not be allowed unless approved by the Town. Sewer slopes shall not exceed 0.10 ft/ft. Drop manholes shall be used to keep the sanitary sewer line grade flatter than this maximum allowable slope.
- 4) In no case shall the diameter of any sewer lateral be less than four (4) inches. The minimum slope for sanitary sewer laterals is one-quarter (1/4) inch per foot.



## 5.2.4 Connection to Existing Sewer

- 1) Manholes that connect a new sewer to an existing sewer shall be plumb and centered on the existing pipe at the elevation designated on the drawings. Care shall be taken not to disturb the alignment of the existing sewer line.
- 2) The cutting of the existing sewer line shall be in the presence of the Town. The cut shall be for the full area of the new pipe and shall be finished so as to leave no projections that will restrict the flow or collect solids. Every precaution shall be taken to prevent foreign material from entering the new or existing sewer lines.
- 3) Brick shall not be used to raise a manhole nor cones broken-out to lower a manhole. Sections shall be removed and grade rings used to adjust manhole lids to the required grade.

## 5.2.5 Lateral Connections to Sanitary Sewer Lines

- 1) Connections shall conform to these Standards. If the sewer lateral is greater than one-half (1/2) the size of the main sewer line, a manhole shall be placed at the main line connection. All laterals shall extend into property line a minimum distance of ten (10) feet and the minimum length of any pipe section used shall be five (5) feet. The minimum depth of cover for sewer laterals is four (4) feet.
- 2) There shall be a maximum distance of five (5) feet from the foundation wall to the first exterior clean-out with a maximum distance between clean-outs of seventy-five (75) feet. There shall also be a clean-out at any ninety (90) degree bend or any combination of bends in excess of ninety (90) degrees.

## 5.2.6 Separation

- 1) Sewer laterals shall not be installed in the same trench as the water service line unless the water service line is placed on a solid shelf excavated at one side of the common trench. At all times the water service shall be separated from the sewer lateral at least eighteen (18) inches horizontally and eighteen (18) inches vertically above the sewer lateral at a minimum of seven (7) feet in depth.
- 2) Water services shall be separated from sewer laterals by at least ten (10) feet horizontally and eighteen (18) inches vertically at a minimum of seven (7) feet in depth, above the sewer lateral in public rights-of-way. Exceptions can be made where the water line is properly encased and approved by the appointed state agency.

## 5.3 FIELD TESTING

### 5.3.1 Air Pressure Testing

If the pipeline is submerged under groundwater, the backpressure caused by the water head, is measured and added to the standard test pressures to compensate for the groundwater effect on the air test.



## SANITARY SEWER, STORM DRAIN LINES & LATERALS

Air shall be applied slowly to the pipeline until the pressure reaches 4.0 psig. The air supply shall then be throttled so that the internal pressure is maintained between 4.0 and 3.5 psig for at least 2 minutes. During this time, the plugs shall be checked with soap solution to detect any plug leakage.

When the pressure reaches exactly 3.5 psig, a stopwatch is started and the time recorded for the pressure to drop to 2.5 psig. The minimum time allowed for this pressure drop shall be computed based on an air loss rate of 2.9 cfm or an air loss rate of 0.0030 cfm per square foot of inner pipe surface under test, whichever rate gives the least time for the pressure drop. Should the time of pressure drop between 3.5 and 2.5 psig be less than the allowable specified time, the Contractor shall make necessary leakage repairs and repeat the air test.

Manhole joints shall be checked for leakage by means of water testing as specified above.

Time in seconds required for pressure drop for 3.5 to 2.5 PSIG (Based on .005 cfm per sq. ft. and 3.5 cfm)

SEC	Pipe Size (in)					Length of Test Section in Linear Feet
	4	6	8	10	12	
25	2.5	5.7	10.2	15.9	22.9	
50	5.1	11.4	20.3	31.7	45.7	
75	7.6	17.1	30.5	47.6	68.6	
100	10.2	22.9	40.6	63.5	91.4	
125	12.7	28.6	50.8	79.3	114.3	
150	15.2	34.3	61.0	95.3	137.2	
175	17.8	40.0	71.1	111.1	160.0	
200	20.3	45.7	81.3	127.0	187.9	
225	22.9	51.4	91.4	142.8	205.4	
250	25.4	57.1	101.6	158.8		
275	27.9	62.8	111.8	174.6		
300	30.5	68.6	121.9			
325	33.0	80.1	132.8			
350	35.6	91.4	142.2			
375	38.1	102.8				
400	40.1					
450	45.7					
500	50.8					
550	55.9					
600	60.9					
650	66.0					
675	68.5					

### 5.3.2 PVC Deflection Test



## SANITARY SEWER, STORM DRAIN LINES & LATERALS

All sewer pipe six inches (6") or larger shall be tested for deflection with a mandrel. The mandrel shall be a rigid device sized to pass through a pipe having five percent (5%) or less deflection. These allowances shall include deformations due to all causes (wall thickness variations, shipping, production, backfill, heat, etc). The mandrel device shall be cylindrical in shape and shall comply with the manufacturer's recommendations.

The mandrel shall be hand pulled through all sewer line mains, lateral sewer lines shall not be subject to this requirement. Any sections of sewer not passing the mandrel shall be uncovered and repaired by the contractor. The contractor shall re-round or replace the sewer to the satisfaction of the Town's representative. All repaired sections shall be re-tested as noted above.

Deflection tests shall be conducted only after the final trench backfill is placed to final grade and compacted.

### 5.3.3 Camera/Electronic Media Testing

The Contractor or his representative (a qualified firm or individual agreed upon by the Public Works Director and the contractor) shall furnish labor, equipment, and materials, including camera and electronic media formats, and shall perform, in the presence of a Town Representative, an internal camera test of the completed pipe before it can be placed in service. The contractor shall supply the Town with a copy of the electronic record. The test shall be subject to the Public Works Director's approval. Any defects in the pipe or the pipe installation noted on the internal camera inspection shall be corrected by the contractor and the repaired section shall be camera inspected after the repair to verify that the defective section has been corrected. Camera testing shall be identified in any bid document that is prepared for or by Brian Head Town as a requirement of the Town.



# CONCRETE CURB, GUTTER AND SIDEWALK

## 6.1 MATERIALS

### 6.1.1 Concrete

All concrete shall conform to the requirements of these Standards. Under no circumstances shall the water cement ratio exceed 0.53 or six (6) gallons of water per bag of cement. The slump shall not exceed the tolerances specified in these Standards.

### 6.1.2 Concrete Forms

All forms shall be made from steel except at curves with a radius smaller than two-hundred (200) feet. They shall be of a size to match the sections shown on the plans. Forms shall be held firmly in place with stakes or other approved means and shall be true to line and grade. Forms for curved sections shall be so constructed and placed that the finish surface of walls and edge of sidewalks, curbs and gutters will not deviate from the arc of the curve.

## 6.2 INSTALLATION

### 6.2.1 Subgrade Preparation

- 1) The developer/contractor shall construct subgrade to the lines and grades approved by the Town. The subgrade shall be properly shaped to conform with the approved cross section and grade and placed and compacted to meet the densities specified in these Standards.
- 2) Placement of concrete on unsuitable materials shall not be permitted. The subgrade surface shall not have any granular material exceeding three-fourths (3/4) inch in diameter.
- 3) Subgrade preparation shall extend three (3) feet beyond back of sidewalk. The elevation of subgrade preparation shall be not lower than the bottom of the back of walk.

### 6.2.2 Joints

- 1) Contraction joints shall be constructed at a minimum of every eight (8) feet by using steel templates one-eighth (1/8) inch in thickness. The templates shall be removed as soon as concrete has set sufficiently to hold its shape. Expansion joints shall be constructed at a minimum of forty (40) feet. Joints in the curb, gutter, and sidewalk shall coincide when the sidewalk is placed adjacent to the curb and gutter.
- 2) At the end of each day's concrete placement, or when work is terminated, or when a delay of more than thirty (30) minutes occurs, the joint shall be made vertical and square ended. In no case shall the day's concrete placement be terminated at a driveway.

### 6.2.3 Finished Surfaces

- 1) All exposed surfaces of the concrete shall be accurately screened to grade, then float finished, edged, and lightly broom finished. Finishing shall be delayed until concrete



## CONCRETE CURB, GUTTER AND SIDEWALK

has reached its initial set and has stopped bleeding. Excessive floating or finishing of concrete surfaces shall not be permitted. The addition of dry cement or water to the newly placed concrete surface shall not be allowed.

### 6.2.4 Curing

- 1) Immediately after final finishing, all surfaces that are exposed to the air shall be coated with curing compound. The compound used shall be a chlorinated rubber type conforming to ASTM C309, Type 1, red pigment that can be readily seen by the Town. The compound shall be applied in accordance with the manufacturer's recommendations.
- 2) The developer/contractor shall be responsible to bring the earth grade to within plus or minus one (1) inch of the top back of walk. This grade shall be maintained for a distance of three (3) feet from back of walk.

### 6.2.5 Removal or Repair of Flatwork or Sidewalk, Curb and Gutter

When concrete is honeycombed, damaged, improperly cured or otherwise defective, the developer/contractor shall remove and replace the structure or structural member containing the defective area. A licensed and qualified contractor is required to take out a no-charge permit to replace any concrete in a Town right-of-way. Any damage to adjoining walk shall also be replaced. The Town will determine the required extent of removal, replacement or repair. No less than a five (5) foot section of concrete shall be replaced. Prior to starting repair work, the developer/contractor shall obtain the Town's approval of its plan for the repair. The developer/contractor shall erect and maintain suitable barriers to protect the finished surface. Any section damaged from traffic or other causes occurring prior to its official acceptance shall be repaired or replaced by the developer/contractor at its own expense in a manner satisfactory to the Town. Failure to comply with specified tolerances may be cause for rejection.

### 6.2.6 American Disabilities Accessibility Standards in Public Street Rights-of-Way

- 1) American Disabilities Accessibility Standards are to be applied during the design, construction, and alteration of street construction or public buildings. The construction of curb ramps shall conform to these Standards.
- 2) Curb ramps complying with ADA standards shall be provided wherever an accessible route crosses a curb. Longitudinal slopes of curb ramps shall be constructed with the least slope possible. The maximum slope of a ramp in new construction shall be one (1) horizontal to twelve (12) vertical. The maximum rise for any run shall be thirty (30) inches. Transitions from ramps to walks, gutters, or streets shall be flush and free from abrupt changes. Maximum slopes of adjoining gutters, road surface immediately adjacent to the curb ramp, or accessible route shall not exceed one (1) horizontal to twenty (20) vertical.



## CONCRETE CURB, GUTTER AND SIDEWALK

- 3) The minimum width of a curb ramp shall be thirty-six (36) inches, exclusive of flared sides.
- 4) The surface of curb ramps shall be stable, firm, and slip resistant.
- 5) If a curb ramp is located where pedestrians must walk across the ramp, or where it is not protected by hand rails or guardrails, it shall have flared sides; the maximum slope of the flare shall be one (1) horizontal to twelve (12) vertical. Curb ramps with returned curbs may be used where pedestrians would not normally walk across the ramp.
- 6) Built-up curb ramps shall be located so that they do not project into vehicular traffic lanes.
- 7) Curb ramps shall be located or protected to prevent their obstruction by parked vehicles.
- 8) Curb ramps at marked crossings shall be wholly contained within the markings, excluding any flared sides.
- 9) If diagonal (comer type) curb ramps have returned curbs or other well- defined edges, such edges shall be parallel to the direction of pedestrian flow. The bottom of diagonal curb ramps shall have a minimum of forty-eight (48) inches of clear space. If diagonal curb ramps are provided at marked crossings, the forty-eight (48)-inch clear space shall be within the markings. If diagonal curb ramps have flared sides, they shall also have at least a twenty-four (24)-inch long segment of straight curb located on each side of the curb ramp and within the marked crossing.
- 10) Any raised islands in crossing shall be cut through level with the street or have curb ramps at both sides of a level area forty-eight (48) inches long between the curb ramps in the part of the island intersected by the crossings.
- 11) Detectable warnings shall comply with currently adopted standards. The area of the ramp and flared sides shall be a visually contrasting surface. The Town will determine on a case by case basis how the surface should be contrasted.



# ASPHALT PAVING AND GRANULAR BASE

## 7.1 MATERIALS

### 7.1.1 Granular Base Course

- 1) Granular base course shall consist of crushed gravel, crushed rock, or crushed blast furnace slag placed on a prepared subgrade as specified in these Standards.
- 2) On that portion of the mineral aggregate passing the No. 40 sieve, the liquid limit shall not exceed twenty-five (25), nor shall the plasticity index exceed six (6), when tested in accordance with AASHTO T-89 and T-90.
- 3) The dry mineral aggregate shall be uniformly graded to conform to one of the gradations listed below when tested in accordance with AASHTO T-27.

Sieve Size	Percent Passing	
	1" Maximum	<sup>3</sup> / <sub>4</sub> " Maximum
1"	100	-
<sup>3</sup> / <sub>4</sub> "	-	100
<sup>1</sup> / <sub>2</sub> "	70-100	-
<sup>3</sup> / <sub>8</sub> "	-	69-100
No.4	41-68	46-75
No.16	21-41	22-44
No.50	10-27	10-28
No.200	4-13	4-13

The Total amount of material passing the No.200 sieve shall be determined by washing with water in accordance with AASHTO T-11.

- 4) Aggregate shall have a percentage of wear not to exceed fifty (50) when tested in accordance with AASHTO T-96. This requirement shall be used only in determining the suitability of the aggregate source and shall not be used for routine control testing.
- 5) Crushed blast furnace slag, if used, shall be uniform in density and quality and have a rodded weight of not less than seventy-five (75) pounds per cubic foot when tested in accordance with AASHTO T-19. Open-hearth slag will not be permitted for use as granular base course.

### 7.1.2 Bituminous Surface Course

- 1) Bituminous surface course shall be in accordance with Section 02786 - Open-Graded Surface Course (OGSC) of the State of Utah Department of Transportation (UDOT) Standards and Specifications for Road and Bridge Construction, latest edition. One-half inch maximum gradation shall be used. A minimum of three (3) inches of asphalt is required unless otherwise specified by the Town.
- 2) Bituminous seal coat shall conform to Section 02785 - Chip Seal Coat of the State of Utah Department of Transportation (UDOT) Standards and Specifications for Road and Bridge Construction, latest edition. AC-b or AC-20 bituminous material shall be used. Seal coats shall be used only if specifically called for on the plans or specified in writing by the Town.



## ASPHALT PAVING AND GRANULAR BASE

- 3) Bituminous prime and tack coats shall conform to Section 02786 - Open-Graded Surface Course (OGSC) of the Utah Department of Transportation (UDOT) Standards and Specifications for Road and Bridge construction, latest edition. Tack coats shall be applied to the edges of existing asphalt when new asphalt is placed adjacent to it or when new asphalt is placed over old asphalt, or new concrete curb.

### 7.2 INSTALLATION

#### 7.2.1 Road Cut Permit

Prior to any road or bridge construction the developer or property owner shall apply for a Road Cut Permit from the Town of Brian Head. Permits shall be issued for a period of sixty (60) days and shall be available at all times when work is under way.

#### 7.2.2 Granular Base Course

The granular base course shall be placed on a properly prepared and compacted subgrade and shall be compacted to at least ninety-five percent (95) percent of maximum density as determined by ASTM D1557. The depth of the granular base course shall be eight (8) inches, unless otherwise approved by the Town following a recommendation from a geotechnical engineer.

#### 7.2.3 Bituminous Surface Course

- 1) A self-propelled lay down machine shall be used on all Town streets. A box type lay down machine may be used on strip paving, patches, and areas where the self-propelled type lay down machine cannot be used as determined by the Town.
- 2) No asphalt shall be placed when the ambient air temperature is less than fifty degrees (50) F. No asphalt shall be placed when there are any frozen materials in the subgrade or the granular base course. Asphalt shall not be placed during rainy weather, when the road is wet, or during other adverse weather conditions. At the time of delivery to the site of the work, the temperature of the asphalt shall not be lower than two hundred sixty degrees (260) F. Compaction shall be complete before the temperature of the asphalt drops below one hundred eighty degrees (180) F. If the asphalt temperature drops below one hundred eighty degrees (180) F, asphalt placement shall be halted.
- 3) Trenches cut during winter months or when asphalt plants are not operating, shall be patched the same day of the cut with a good quality cold mix and maintained until asphalt plants open. When the asphalt plants open, the cold patch shall be removed and a new patch of hot mix asphalt shall be placed within twenty (20) days of plant opening.

#### 7.2.4 Roadway Details

All new roadways, intersections, cul-de-sacs, sidewalks, curb and gutter, and retaining structures shall be constructed and repairs in compliance with standard drawings 101, 102,



## ASPHALT PAVING AND GRANULAR BASE

104, 106, 107, 108, 109, 110, 111, 112, 113, 114, 115 and 504 contained in the Appendix of these Standards.



# PORTLAND CEMENT CONCRETE

## 8.1 MATERIALS

### 8.1.1 Portland Cement Concrete

- 1) Portland Cement shall conform to the requirements of ASTM C-150. Type II cement shall be used unless otherwise specified.
- 2) Water shall be clean and free from damaging amounts of oil, salt, acid, alkali, organic matter, or other deleterious substances and shall meet the requirements of ACI 318-77.
- 3) Aggregates shall conform to the requirements of ASTM C-33 and shall be well graded and free from substances that are chemically active relative to hydrated cement.
- 4) Coarse aggregate shall consist of clean, hard, and durable particles of a mixture of crushed and natural aggregate and shall be well graded to produce as dense a mixture as practical. Deleterious substances in the aggregate shall be limited as follows:

Deleterious Substance height	
Deleterious Substance	Percent by Weight
Soft Fragments	3.0
Coal Lumps	1.0
Clay Lumps	0.5
Material passing #100 sieve	1.5
Organic Material	0.1
Total for any or all of above	3.0

- 5) Abrasion loss, as determined by the Los Angeles Abrasion Test, shall not be more than forty percent (40%) by weight.
- 6) Loss on exposure to five cycles of the Sodium Sulfate Soundness Test shall not be more than eight percent by weight.
- 7) The maximum size of aggregate to be used shall not exceed one and one-half (1 ½) inches in terms of the size definition contained in ASTM Standards, except that the maximum size shall not exceed:
  - a. 1/5 of the narrowest dimension between the sides of forms
  - b. 1/3 of the depth of slabs
  - c. 3/4 of the minimum clear spacing between individual reinforcing bars, wires, bundles of bars, and pre-stressing tendons and ducts
- 8) Fine aggregate shall consist of clean, hard, and durable particles of a mixture of crushed and natural aggregate and shall be well graded to produce as dense a mixture as practical. Deleterious substances in the aggregate shall be limited as follows:

Deleterious Substance height	
Deleterious Substance	Percent by Weight
Soft Fragments	3.0
Coal	1.0
Material passing #200 sieve	3.0
Micaceous or Flaky Particles	3.0
Total for any or all of above	5.0



## PORTLAND CEMENT CONCRETE

Performance of the Organic or Color-metric test using sodium hydroxide shall result in a color that is lighter than Number 2.

9) Unless otherwise specified in these Standards, un-reinforced concrete flat work shall have a slump range of one (1) to three (3) inches, reinforced concrete shall have a slump range of two (2) to four (4) inches unless super plasticized, and mass concrete shall have a slump range of two (2) to six (6) inches.

### 8.1.2 Additives and Admixtures

- 1) Air-Entraining Admixtures shall conform to "Specifications for Chemical Admixtures to Concrete," ASTM C494. Admixtures containing chloride ions shall not be used in pre-stressed concrete or in concrete containing embedded aluminum or galvanized accessories.
- 2) The Town must approve any use of calcium chloride, in no case shall more than two (2) percent of calcium chloride be used. In no case shall calcium chloride be used in any reinforced slab
- 3) The Town must approve any use of fly-ash or other pozzolans. Pozzolans shall conform to the requirements of ASTM C618. In no case shall more than fifteen (15) percent of the Portland Cement be replaced by an equal weight of pozzolans.
- 4) Curing compounds shall meet the requirements of ASTM C309. The compound shall be applied in accordance with the manufacturer's recommendations as soon as possible after final finishing. Transparent curing compounds shall consist of a liquid that is free from suspended matter at the time of application and shall be sufficiently low in viscosity to result in an even, uniform coating when applied by spraying. The compound shall be sufficiently transparent and free from permanent color to result in no pronounced change in color from that of the natural concrete at the conclusion of the curing period. However, the compound shall contain a red pigment dye, conforming to the requirements of ASTM C309 Type 1 Class B, sufficient to render the film distinctly visible on the concrete for a period of at least four (4) hours after application.

### 8.1.3 Reinforcing Steel

- 1) Reinforcing steel shall conform to the requirements of ASTM A615 and shall be of the sizes and grade specified on the plans. Reinforcing steel shall be clean and free from rust; scale, paint, oil, grease, dirt or other foreign matter that might prevent or impair the formation of a bond with the concrete.
- 2) Steel welded wire fabric shall conform to the requirements of ASTM A185 and shall be of the sizes and grade specified on the plans. Welded wire fabric shall be clean and free from rust, scale, paint, oil, grease, dirt or other foreign matter that might prevent or impair the formation of a bond with the concrete.



## PORTLAND CEMENT CONCRETE

- 3) Reinforcing steel shall be cut and bent per the requirements of ACI 315 and shall not be bent, heated or straightened in a manner that will injure the material. Reinforcing steel with kinks, cracks, or improper bends will be rejected.
- 4) All epoxy coated reinforcing steel shall be coated according to AASHTO M-284. Only those bars required by the approved plans shall be coated. All bent bars shall be coated after bending. Epoxy coated bars that are to be cut in the field shall be either sawed or sheared but shall not be torch-cut. The sawed or sheared end and all other damaged coating shall be repaired using a specified patching or repair material approved by the manufacturer for epoxy coating repair.

### 8.1.4 Accessories

Preformed expansion joint filler shall conform to the requirements of ASTM D-1752 or ASTM D-994.

## 8.2 CONCRETE MIX DESIGN

### 8.2.1 Strength Requirements

- 1) Unless otherwise specified, the minimum compressive strength of concrete at twenty-eight (28) days shall be as follows:
  - a. 4,000 psi for all reinforced concrete
  - b. 3,500 psi for all flat work, sidewalks, curbs, gutters, pavements, and unreinforced slabs and footings
  - c. 2,500 psi for thrust blocks, thrust anchors, and mass concrete
- 2) Rejection of concrete on the basis of strength shall be considered if the average of any three consecutive compressive strength tests is below the required value or if any individual compressive strength test is more than 500 psi below the required value.
- 3) The Town shall require tests or otherwise investigate concrete that fails to meet the strength requirements and may elect to have the concrete replaced at the expense of the developer/contractor. Any investigation of reinforced concrete structures shall conform to the requirements of ACI 318-77 Section 4.8.4. Load tests, if required, shall be performed at the expense of the developer/contractor.
- 4) Procedures for testing concrete compressive strength shall be in accordance with the requirements of ASTM C31 Method of Making and Curing Concrete Test Specimens in the Field, ASTM C39 Method of Test for Compressive Strength of Cylindrical Concrete Specimens, and ASTM C142 Method of Obtaining and Testing Drilled Cores and Sawed Beams of Concrete.
- 5) The proportions of the aggregates shall serve to produce a concrete mixture that will work readily into the corners and angles of the forms and around reinforcement when consolidated, but will not segregate or exclude free water during consolidation.
- 6) Prior to placement of concrete, the developer/contractor shall furnish the Town with a statement of the proposed materials, mix proportions, and admixtures. The statement shall include evidence that the materials and the proportions will produce



## PORTLAND CEMENT CONCRETE

concrete conforming to this specification. The materials and proportions so stated shall constitute the job mix. The source and character of aggregates and the type or brand of cement or admixture shall not be changed without approval by the Town.

- 7) For curb, gutter, sidewalk, and other flat work the water cement ratio shall not exceed 0.53 by weight or six (6) gallons per bag of cement. Only air entraining admixtures shall be allowed for flat work exposed to freezing temperatures when wet, without written approval from the Town.
- 8) Materials shall be stockpiled and combined by methods that will prevent segregation or contamination of aggregates and to ensure accurate proportioning of the ingredients in the mix.
- 9) Cement shall be measured by weight or in bags of ninety-four (94) pounds each. When cement is measured in bags, no fraction of a bag shall be used unless weighed.
- 10) Aggregates shall be measured by weight. Mix proportions shall be based on saturated, surface-dry weights. The batch of each aggregate shall be the required saturated, surface-dry weight plus the weight of the surface moisture it contains.
- 11) Water shall be measured by volume or by weight, to within one percent of the total quantity of water required for the batch. No water in excess of the amount specified in the mix design for the job mix shall be added to the concrete.
- 12) Admixtures shall be measured within plus or minus three (3) percent.
- 13) Concrete shall be uniform and thoroughly mixed when delivered to the work site. Variations in the slump of more than one (1) inch within the batch will be considered evidence of inadequate mixing and shall be corrected by increasing mixing time or by other means.
- 14) For stationary mixtures, after all cement aggregate and water are in the mixer drum, the mixing time shall not be less than one and one-half (1½) minutes.
- 15) Unless otherwise specified, volumetric batching and continuous mixing at the construction site will be permitted only when approved by the Town. The batching and mixing equipment shall conform to the requirements of ASTM C685 and shall be demonstrated prior to the placement of concrete, by tests with the job mix, to produce concrete meeting the specified proportioning and uniformity requirements. Concrete made by this method shall be produced, inspected, and certified in conformance with Sections 6, 7, 8, 13 and 14 of ASTM C685.

### 8.3 PLACING CONCRETE

#### 8.3.1 Forms

- 1) Forms shall be of wood, plywood, steel or other approved material and shall be mortar tight. The forms and associated false work shall be substantial and unyielding and shall be constructed so that the finished concrete will conform to the specified dimensions and contours. Form surfaces shall be clean, smooth, and free from holes, dents, sags or other irregularities. Forms shall be coated with non-staining form oil



## PORTLAND CEMENT CONCRETE

before being set into place. Care shall be taken to prevent oil from getting on reinforcement or anchors. Reinforcement or anchors shall be clean before placing of concrete.

- 2) Metal ties or anchors within the forms shall be equipped with cones, she-bolts, or other devices that permit their removal to a depth of at least one inch without injury to the concrete. Ties designed to break off below the surface of the concrete shall not be used without cones.
- 3) All edges that will be exposed to view when the structure is completed shall be chamfered or finished with molding tools.
- 4) Forms shall not vary from vertical grade by more than two-hundredths (0.02) feet and from horizontal alignment by more than five-hundredths (0.05) feet. All forms shall have smooth even lines in both the horizontal and vertical plane.

### 8.3.2 Conveying Concrete

- 1) When the air temperature is eighty (80) degrees F or greater, a maximum time of forty-five (45) minutes will be allowed from the time the cement mix is added to the concrete until the concrete mix is discharged from the carrier. When the temperature is less than eighty (80) degrees F, a maximum time of ninety (90) minutes will be allowed from the time the water is added to the concrete mix until the concrete mix is discharged from the carrier. The concrete shall be conveyed from the mixer to the forms as rapidly as practicable by methods that will prevent segregation of the aggregates or loss of mortar. Concrete shall not be dropped more than five (5) feet vertically unless suitable equipment is used to prevent segregation.
- 2) Concrete shall not be placed until the subgrade, forms, and steel reinforcement have been inspected and approved by the Town.
- 3) The concrete shall be initially placed as closely as possible to its final position in the forms and shall be worked into the comers and angles of the forms and around all reinforcement and embedded items in a manner to prevent segregation of aggregates or excessive laitance. Unless otherwise specified, slab concrete shall be placed to the design thickness in one continuous layer. Formed concrete shall be placed in horizontal layers not more than twenty (20) inches thick. Hoppers, chutes, pipes, and concrete pumps shall be used as necessary to prevent splashing of mortar on the forms and reinforcing steel above the layer being placed.
- 4) Immediately after the concrete is placed in the forms, it shall be consolidated by spading, hand tamping, or vibration as necessary to insure smooth surfaces and dense concrete. Each layer shall be consolidated to insure a monolithic bond with the preceding layer. If the surface of a layer of concrete in place sets to a degree that it will not flow and merge with the succeeding layer when spaded or vibrated, the developer/contractor shall discontinue placing concrete and shall make a construction joint.



## PORTLAND CEMENT CONCRETE

- 5) If concrete placement is discontinued before a complete horizontal layer is in place, a vertical bulkhead, at a location approved by the Town, shall be used to form the unfinished end of the layer.
- 6) No concrete flat work shall be placed or finished in the rain or snow.
- 7) In walls and columns, as each lift is completed, the top surfaces shall be immediately and thoroughly protected from any condition that might adversely affect the hardening of the concrete.

### 8.3.3 Construction, Expansion, and Contraction Joints

- 1) Construction joints shall be installed as shown on the drawings. If construction joints, not shown on the drawings are needed, they shall be placed in locations approved by the Town.
- 2) Where a feathered edge would be produced at a construction joint, as in the top surface of a sloping wall, an insert form shall be used so that the resulting edge thickness on either side of the joint is not less than six (6) inches.
- 3) Steel tying and form construction to be accomplished adjacent to newly placed concrete shall not be started until the concrete has cured at least twelve (12) hours. Before new concrete is deposited on or against newly hardened concrete, the forms shall be kept moist for at least one hour prior to placement of the new concrete.
- 4) Expansion and contraction joints shall be made only at the locations shown on the drawings.
- 5) Exposed concrete edges at expansion and contraction joints shall be carefully tooled or chamfered, and the joints shall be free of mortar and concrete. Joint filler shall be left exposed for its full length with clean and true edges.
- 6) Preformed expansion joint filler shall be held firmly in the correct position while the concrete is placed.
- 7) When open joints are specified, they shall be constructed by the insertion, and subsequent removal, of a wooden strip, metal plate, or other suitable template in such a manner that the comers of the concrete will not be chipped or broken. The edges of open joints shall be finished with an edging tool prior to removal of the joint strips.

### 8.3.4 Waterstop

Waterstop shall be held firmly in the correct position while the concrete is placed. Joints in metal waterstop shall be soldered, brazed, or welded. Joints in rubber or plastic waterstop shall be cemented, welded, or vulcanized as recommended by the manufacturer.

### 8.3.5 Air Content and Consistency

- 1) Concrete, that after curing, will be exposed to freezing temperatures while wet shall contain entrained air within the following limits:

Normal Maximum Aggregate size (in)	Total Air Content (% by Vol/cu ft)
---------------------------------------	---------------------------------------



## PORTLAND CEMENT CONCRETE

3/8"	6-10
1/2"	5-9
3/4"	4-8
1 - 1 1/2"	3.5 - 6.5

2) If the content of entrained air falls below the minimum value set as determined from two or more tests in a batch, the Town may reject the concrete.

### 8.3.6 Rejection Based on Excessive Slump

1) If the slump measurements are inconsistent with the job mix, the Town can reject the concrete if the adequacy of the batch is in question.

Inconsistency shall be defined by at least two slump tests, from the same load, falling more than two (2) inches below the job mix slump.

2) The first slump test will be taken after the first yard of concrete has been placed. If this test fails a second test will be taken immediately after.

### 8.3.7 Finishing Formed Surfaces

1) All fins and irregular projections shall be removed from exposed surfaces.

2) The holes produced by the removal of the form ties, cones, bolts, and she-bolts, shall be cleaned, wetted, and filled with a dry-pack mortar consisting of one (1) part portland cement, three (3) parts sand that will pass a #16 sieve, and water just sufficient to produce a consistency such that the filling is at the point of becoming rubbery when the material is solidly packed.

### 8.3.8 Finishing Unformed Surfaces

1) All exposed surfaces of the concrete shall be accurately screeded to grade, then float finished, and lightly broom finished, unless otherwise specified. Finishing shall be delayed until concrete has reached its initial set and stopped bleeding. Excessive floating or trowel finishing shall not be permitted.

2) The addition of dry cement or water to the surface of the screeded concrete to expedite finishing shall not be permitted.

3) Joints and edges on unformed surfaces that will be exposed to view shall be chamfered or finished with molding tools.

### 8.3.9 Curing

Immediately after final finishing, surfaces that are exposed to the air shall be coated with curing compound.

### 8.3.10 Removal or Repair of Concrete

1) When concrete is honeycombed, damaged, improperly cured, or otherwise defective, the developer/contractor shall remove and replace the structure or structural



## PORTLAND CEMENT CONCRETE

member containing the defective area. The Town shall have cause for rejection when the requirements of these Standards are not met.

2) The developer/contractor shall erect and maintain suitable barriers to protect the finished surface. Any section damaged by traffic or other causes occurring prior to its official acceptance by the developer/contractor at his own expense in a manner satisfactory to the Town.

### 8.3.11 Placing Concrete in Cold Weather

1) When the ambient temperature is expected to drop below forty (40) degrees F at the time concrete is delivered to the work site, during placement, or at any time during the curing period, the temperature of the concrete at time of placement shall not be less than fifty (50) degrees F nor more than ninety (90) degrees F. The temperature of aggregates and mixing water shall not be more than one hundred (100) degrees F just prior to mixing with the cement.

2) Concrete structures shall be insulated or housed and heated if the daytime ambient temperature is less than forty (40) degrees F. The temperature of the concrete and air adjacent to the concrete shall be maintained at not less than fifty (50) degrees F or more than ninety (90) degrees F for the duration of the curing period.

3) The method of insulation shall be by standard concrete insulation blankets or straw. When using straw, the contractor shall install two layers of plastic sheeting with six (6) inches of straw between them. Methods of insulating, housing and heating the structure shall conform to ACI 306 Recommended Practice for Cold Weather Concreting.

4) When dry heat is used to protect concrete, some means of maintaining an ambient humidity of at least forty (40) percent shall be provided unless the concrete has been coated with curing compound or is covered with an approved impervious material.

### 8.3.12 Placing Concrete in Hot Weather

1) When the ambient temperature is expected to rise above ninety (90) degrees F at the time concrete is delivered to the work site, during placement, or for the first twenty-four (24) hours after placement, the contractor shall maintain the temperature of the concrete below ninety (90) degrees F. The methods used shall conform to ACE 605 Recommended Practice for Hot Weather Concreting.

2) The concrete shall be placed immediately after mixing. Truck mixing shall be delayed until only enough time remains to finish mixing before the concrete is placed. Exposed concrete surfaces that tend to dry or set too rapidly shall be continuously moistened by means of fog sprays or otherwise protected from drying during the time between placement and finishing and curing.

3) Finishing of slabs and other exposed surfaces shall be started as soon as the condition of the concrete allows, and completed without delay.



## PORTLAND CEMENT CONCRETE

- 4) Concrete surfaces exposed to the air shall be covered as soon as the concrete has hardened sufficiently and shall be kept continuously wet for at least the first twenty (24) hours of the curing period.
- 5) Formed surfaces shall be kept completely and continuously wet for the duration of curing period or until curing compound is applied as specified in these Standards.

### 8.3.13 Inspection and Testing

- 1) The Town shall have free access to the construction site and batch plant. Proper facilities shall be provided for the Town to inspect materials, equipment, and processes and to obtain samples of the concrete. Any inspections and tests performed by the Town will be conducted in a manner that will minimize disruptions to the production and delivery of concrete.



# WORK SITE TRAFFIC CONTROL

## 9.1 GENERAL REQUIREMENTS

### 9.1.1 Purpose

- 1) Work site traffic control shall provide for safe and expeditious movement of traffic through construction and maintenance work zones at all times. The developer/contractor and other utilities (hereinafter referred to as work agencies) shall provide and maintain all construction signs, barricades, warning lights, flagmen or uniformed law enforcement officers required for the proper protection, direction, and traffic control within the construction or maintenance work zone.
- 2) Traffic control devices and methods shall serve to protect the motoring public, protect the work force, provide a safe and expeditious flow of traffic, provide for efficient and safe construction and maintenance operations, and maintain good public relations.

### 9.1.2 Standards and Requirements

The requirements, standards, and methods of application shall conform to the Manual on Uniform Traffic Control Devices (MUTCD). Typical situations, indicating the proper application of approved devices to control traffic through construction and maintenance areas, are illustrated in the MUTCD. The application of these devices to other circumstances shall be handled in a manner consistent with the MUTCD. Reference to the MUTCD shall include the revisions adopted by the State of Utah Department of Transportation.

### 9.1.3 Permission to Restrict Traffic on Town Streets

- 1) All work agencies and persons must obtain authorization or in some cases a permit for partial or complete closure of any public right-of-way, street, or sidewalk within the Town of Brian Head. All requests to restrict right-of-way will be directed to the Town. Requests that require partial or complete closure of any Town street or sidewalk, detouring or rerouting of pedestrian traffic, or other similar public impacts shall include a Traffic Control Plan that must be approved by the Town. The Town can require a Traffic Control Plan for any project that impacts a Town street, right-of-way, or sidewalk. Complete closure of Town Street for more than twenty (24) hours will require Town Council approval. The Traffic Control Plan (TCP) may range in complexity from, use of the typical illustrations in the MUTCD, to a detailed site plan displaying signing, barricading, material delivery areas, construction office, utility poles, staging areas, and construction phasing. In all cases the TCP must address satisfactorily all of the requirements of the MUTCD for the project. Exceptions to the requirements of the MUTCD must be requested in writing by the applicant, and be approved by the Town and shall be added to the TCP.
- 2) All permits and TCPs must be kept on the job site.
- 3) Street closures of any type will not be permitted without advance notice, except during emergency conditions. The Town reserves the right to deny any street closure



## WORK SITE TRAFFIC CONTROL

permit during anytime, when in their judgment, the traffic restriction could result in unbearable congestion or unnecessary accident potential.

### 9.1.4 General Traffic Control Regulations

- 1) A traffic lane shall not be considered as satisfactorily open to traffic unless it is at least twelve (12) feet wide and is paved with hot mix or cold mix asphalt paving and is surrounded by or adjacent to existing pavement. Where existing pavement has been removed, a traffic lane shall not be considered as satisfactorily open to traffic unless it is graded reasonably smooth and maintained dust free. The major streets shall be patched the same day as work is done and all other streets shall be patched within forty-eight (48) hours.
- 2) Local access shall be maintained to all properties on all streets whenever possible. When local access cannot be maintained, the work agency shall notify the affected property owner, resident, or tenant a minimum of twenty-four (24) hours in advance and restore access as soon as possible.
- 3) Access to fire stations, police stations, hospitals and schools shall be maintained at all times. When access restrictions are necessary, the work agency shall coordinate such access restrictions with the responsible person in charge of the affected fire station, police station, hospital, or school.
- 4) Vehicles that are not essential to the work shall not be permitted to park in the work area that is barricaded or otherwise marked. Vehicles required in the work area shall park down-traffic from the immediate work area. Parking of private vehicles shall be out of the work area and in conformance with parking regulations in the surrounding area. At no time shall the work agency vehicles or equipment impede the traffic lane adjacent to the work site.



**APPENDIX A**  
**STANDARD DRAWINGS**



**BRIAN HEAD TOWN**  
*Standard Drawing Index*

<u>Roadway Details</u> (former # in brackets)	<u>No.</u>
Standard Intersection Detail (101).....	101
Standard Roadway (50' Right-of-Way) Detail (102).....	102
Standard Cul-De-Sac Detail (104).....	104
Turning Area Details (106) .....	106
Curb and Gutter Joint Details (107) .....	107
Sidewalk Ramp at Corner Landing at Sidewalk Level (108) .....	108
Sidewalk Ramp at Corner Landing at Street Level (109).....	109
Temporary Asphalt Concrete "T" Patch (110) .....	110
Waterway Transition Structure (111) .....	111
Concrete Pavement Joints (112) .....	112
Reinforced Concrete Curb Wall (113) .....	113
36" Concrete Retaining Wall (114) .....	114
Typical Trench Details (115).....	115

Storm Drain Details

Catch Basin-Single & Double Grate for Roll Curb and Gutter (204).....	204
Rectangular Storm Drain Cleanout (206).....	206
Dipstone (207).....	207

Sanitary Sewer Details

Standard Manhole Details (302).....	300
Junction & Drop Manhole Details (302 & 303) .....	301
Manhole Frame & Cover Details.....	302
Manhole Step detail.....	303
Typical Residential Sewer Connection Details (301).....	304
PVC Service Connection - Existing PVC Sewer Mains Detail .....	305
PVC Service Connection - New PVC Sewer Mains Detail .....	306
Grease Interceptor Detail .....	307

Culinary Water Details

Water Service Detail (401) .....	401
Megalug Thrust Restraint Details (402) .....	402
Blow Off Valve (403) .....	403
Standard Gate Valve .....	404
Standard Fire Hydrant Assembly Detail (401).....	405
1½" – 4" Water Meter.....	406
Water Meter with Fire Flow.....	407

Miscellaneous Details

Testing and Inspection Standards (501) .....	501
Street Sign and Monument Details (502) .....	502
Street Light Pole Details (503) .....	503
Rock Retaining Wall (504) .....	504

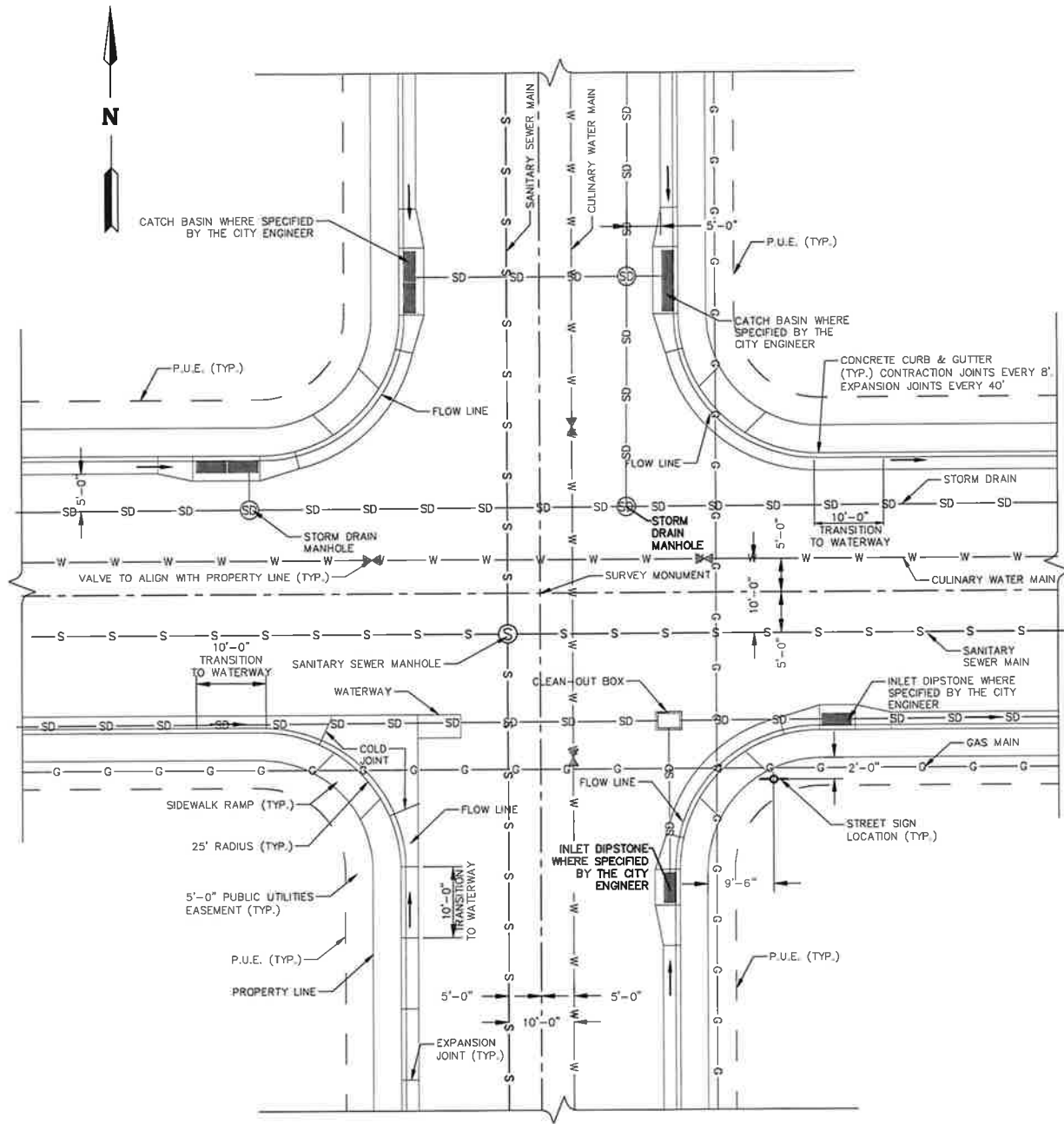

**NOTE:**  
 WATERLINES SHALL BE LOCATED ON THE NORTH AND EAST SIDE OF  
 CENTER LINE AND SEWER LINES SHALL BE LOCATED ON THE SOUTH AND  
 WEST SIDE OF CENTERLINE.

BRIAN HEAD TOWN

STANDARD INTERSECTION DETAIL

REVISIONS		
DATE	DESCRIPTION	BY

STANDARD DWG. NO.	
101	1 OF 1
APPROVED:	
DATE:	BY: LBB

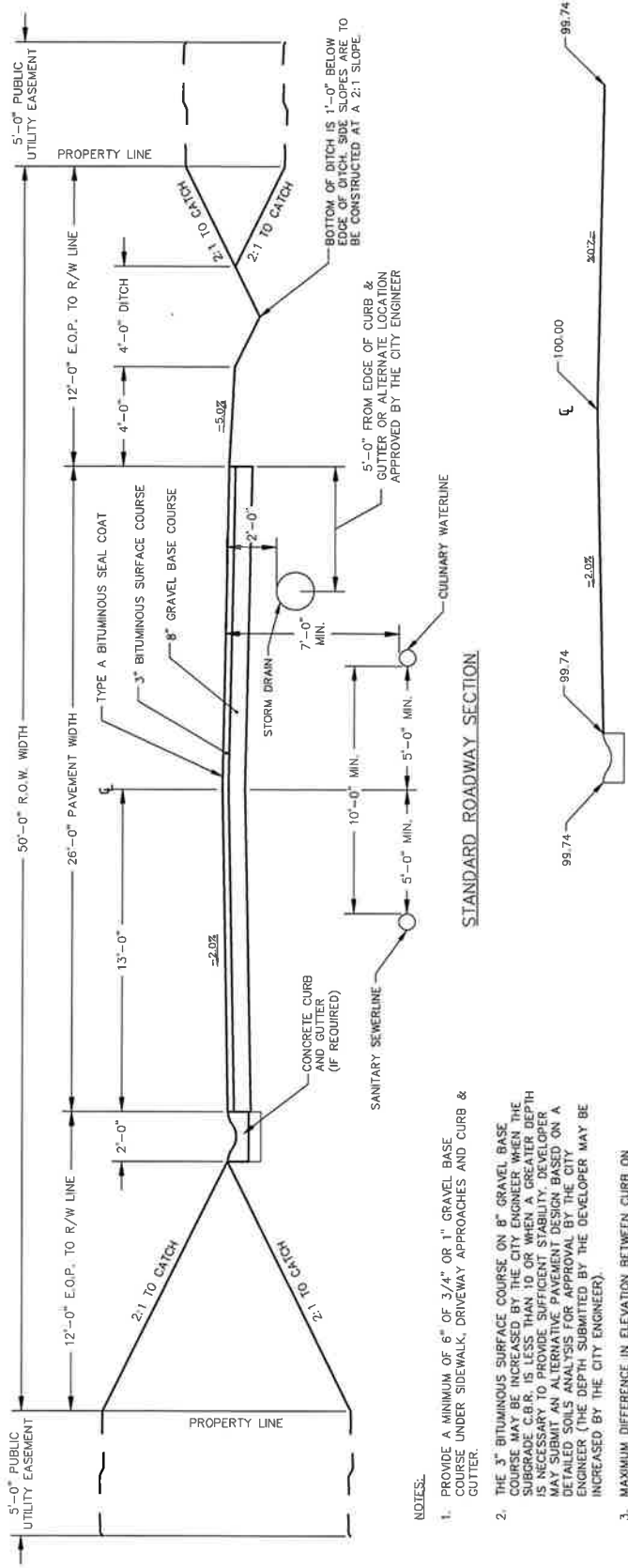

STANDARD ROADWAY SECTION

NOTES:

1. PROVIDE A MINIMUM OF 6" OF 3/4" OR 1" GRAVEL BASE COURSE UNDER SIDEWALK, DRIVEWAY APPROACHES AND CURB & GUTTER.
2. THE 3" BITUMINOUS SURFACE COURSE ON 8" GRAVEL BASE COURSE MAY BE INCREASED BY THE CITY ENGINEER WHEN THE SUBGRADE C.B.R. IS LESS THAN 10 OR WHEN A GREATER DEPTH IS NECESSARY TO PROVIDE SUFFICIENT STABILITY. DEVELOPER SHALL PROVIDE A STABILITY ANALYSIS TO BE REVIEWED ON A DETAILED SOILS ANALYSIS FOR APPROVAL BY THE CITY ENGINEER (THE DEPTH SUBMITTED BY THE DEVELOPER MAY BE INCREASED BY THE CITY ENGINEER).
3. MAXIMUM DIFFERENCE IN ELEVATION BETWEEN CURB ON OPPOSITE SIDE OF STREET SHALL NOT EXCEED 1'-0".
4. ON ARTERIAL STREETS THE DESIGN ENGINEER WILL PROVIDE A PAVEMENT DESIGN FOR REVIEW BY THE TOWN. LOCATION OF SIDEWALK AND CURB & GUTTER MAY VARY ON INDIVIDUAL ARTERIAL STREETS PER DIRECTION BY THE CITY ENGINEER. WALKS ARE 6' WIDE.
5. IF CURB & GUTTER IS REQUIRED, FOLLOW THE LEFT SIDE OF THE ROADWAY SECTION. IF CURB & GUTTER IS NOT REQUIRED, FOLLOW THE RIGHT SIDE OF THE ROADWAY SECTION.

ELEVATION DIFFERENCE FOR TYPICAL ROAD SECTION

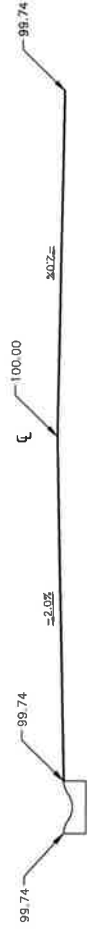

BRIAN HEAD TOWN

STANDARD ROADWAY (50' RIGHT-OF-WAY) DETAILS

REVISIONS		
DATE	DESCRIPTION	BY

STANDARD DWG. NO.	
102	1 OF 1
APPROVED:	
DATE:	BY: LBB

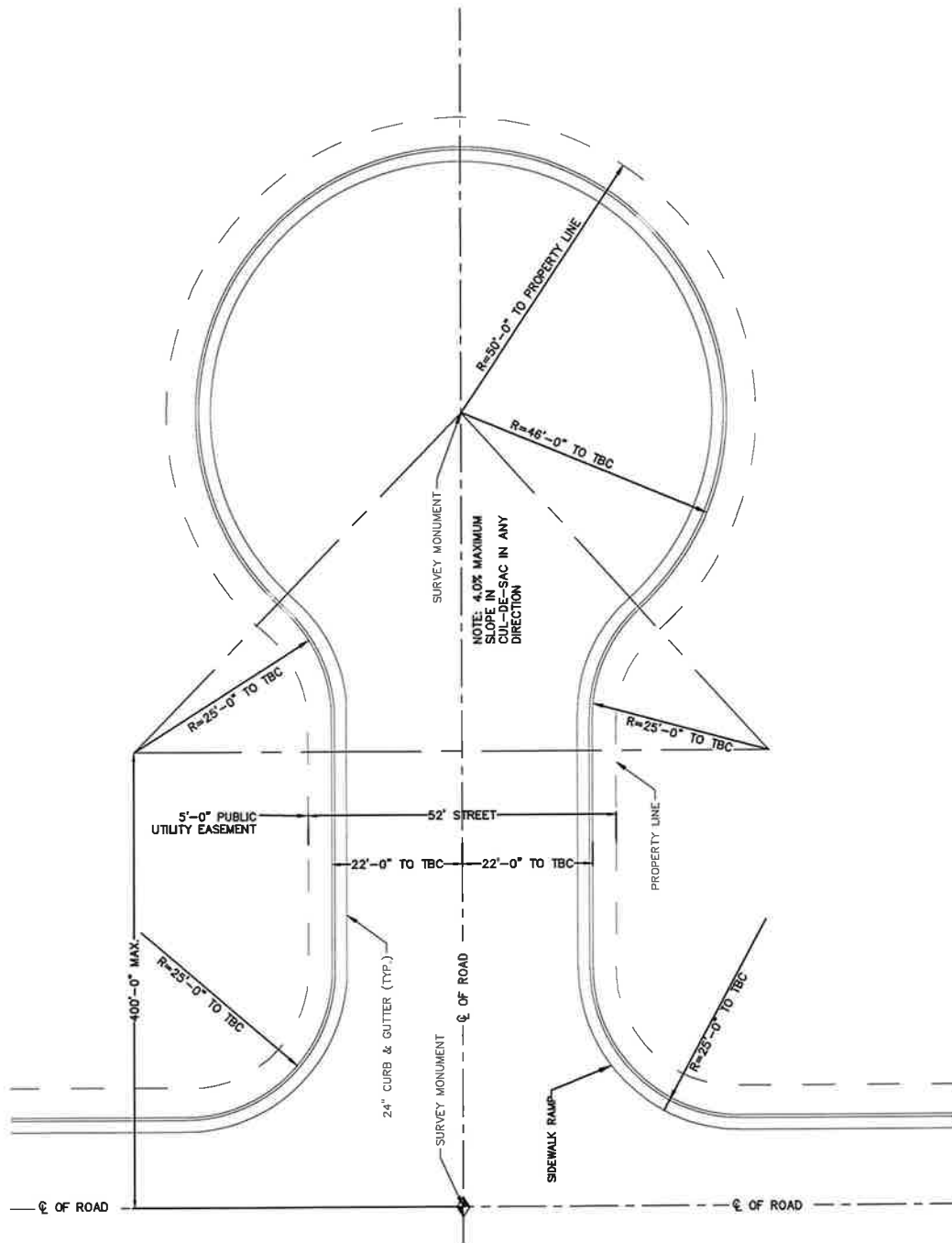

BRIAN HEAD TOWN

STANDARD CUL-DE-SAC DETAIL

REVISIONS		
DATE	DESCRIPTION	BY

STANDARD DWG. NO.	
104	1 OF 1
APPROVED:	
DATE:	BY: LBB

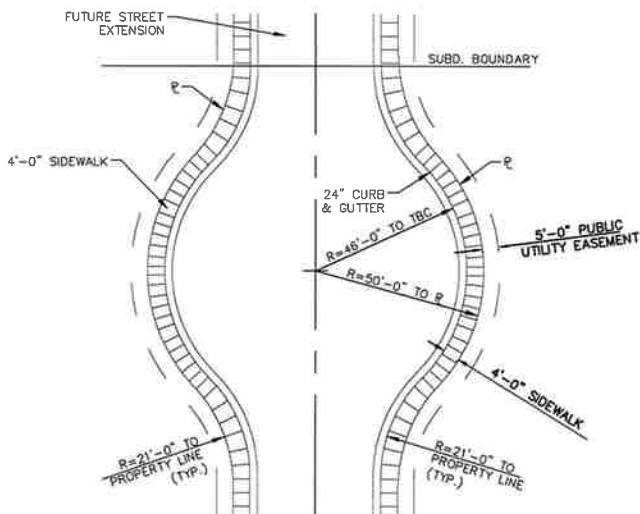
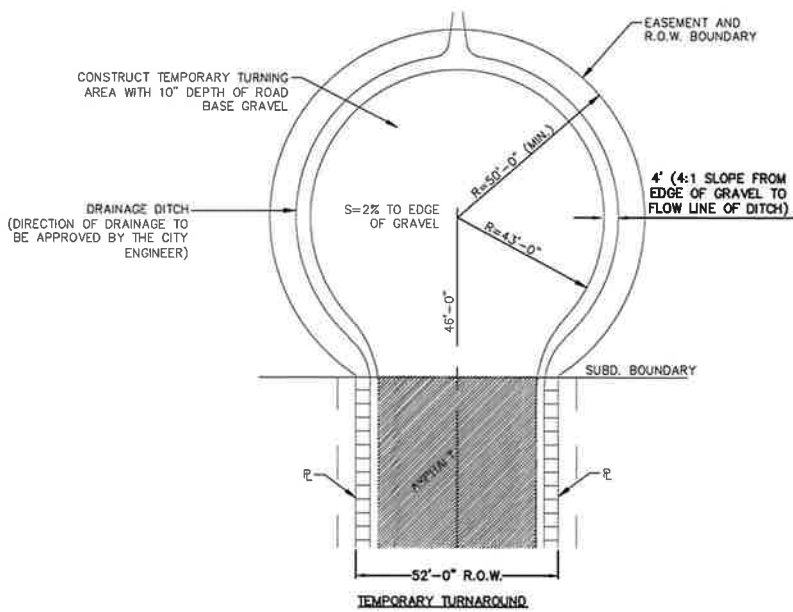

**PERMANENT STREET BUBBLE**  
 TO BE USED AS TURN AREA ON TEMPORARY DEAD END STREET WHEN DISTANCE FROM NEAREST STREET INTERSECTION IS GREATER THAN 400LF. OR WHERE A TEMPORARY TURNAROUND OUTSIDE OF SUBDIVISION IS NOT POSSIBLE.

BRIAN HEAD TOWN

REVISIONS		
DATE	DESCRIPTION	BY

TURNING AREA DETAILS

STANDARD DWG. NO.	
106	1 OF 1
APPROVED:	
DATE:	BY: LBB

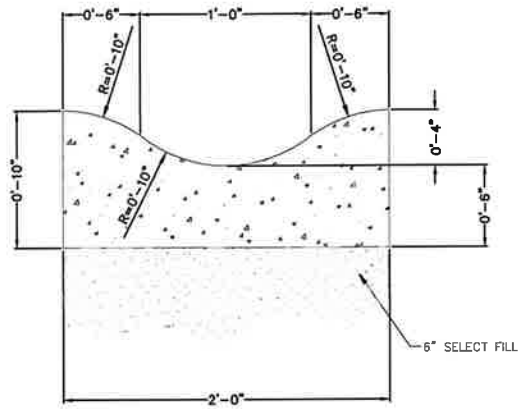

ROLLED CURB AND GUTTER

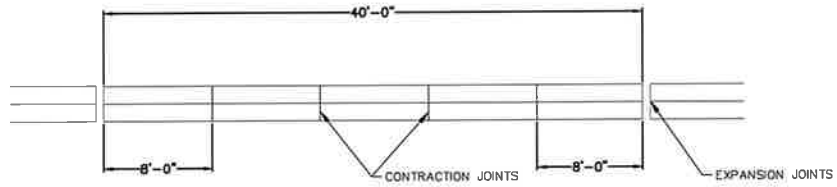

CURB AND GUTTER DETAIL

BRIAN HEAD TOWN

REVISIONS		
DATE	DESCRIPTION	BY

CURB AND GUTTER JOINT DETAILS

STANDARD DWG. NO.	
107	1 OF 1
APPROVED:	
DATE:	BY: LBB

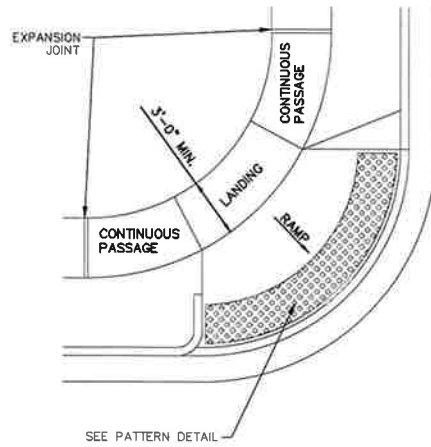

TABLE OF MAXIMUM SLOPE		
ELEMENT OF WORK	NEW CONSTRUCTION	MODIFICATIONS
RAMP (c)	1:12 (8.33%)	1:10 (10%) (b)
LANDING	1:50 (2%)	1:25 (4%)
TRANSITION	1:20 (5%)	1:20 (5%)

NOTE:  
ADD BUMP PAD PER ADA STANDARD  
AS ADOPTED BY THE STATE OF UTAH  
DEPARTMENT OF TRANSPORTATION.

(c) VARIANCES: GET WRITTEN APPROVAL FROM  
THE ENGINEER WHEN THE SLOPE IS GREATER  
THAN SPECIFIED.

(b) RAMP LENGTH SHALL BE 10'-0" MAXIMUM  
WHEN THE RAMP SLOPE EXCEEDS 1:12 (8.33%)

BRIAN HEAD TOWN

REVISIONS		
DATE	DESCRIPTION	BY

SIDEWALK RAMP AT CORNER LANDING  
AT SIDEWALK LEVEL

STANDARD DWG. NO.	
108	1 OF 1
APPROVED:	
DATE:	BY: LBB

GRADE %	"B" TO "A"	"A" MIN.	"B" MIN.
-8 TO -5.01	4'-6"	21'-6"	
-5 TO -4.01	4'-6"	15'-0"	
-4 TO -3.01	4'-6"	12'-0"	
-3 TO -2.01	5'-0"	9'-6"	
-2 TO -1.01	5'-6"	8'-0"	
-1 TO 1	7'-0"	7'-0"	
1.01 TO 2	8'-0"	5'-6"	
2.01 TO 3	9'-6"	5'-0"	
3.01 TO 4	12'-0"	4'-6"	
4.01 TO 5	15'-0"	4'-6"	
5.01 TO 6	21'-6"	4'-6"	

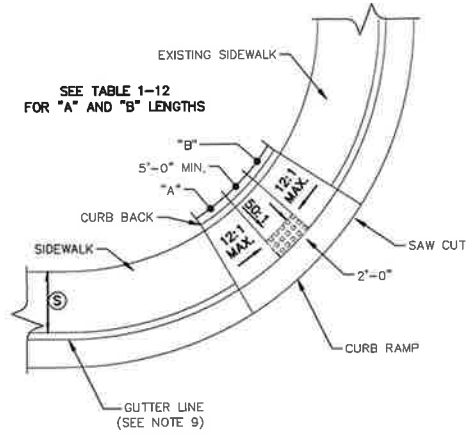

**LEGEND**

- Ⓢ SIDEWALK, 6'-0" NORMAL, SEE NOTE 7.
- ▨ STAMPED & COLORED CONCRETE, SEE NOTE 10.

**NOTE:**  
ADD BUMP PAD PER ADA STANDARD AS ADOPTED BY THE STATE OF UTAH DEPARTMENT OF TRANSPORTATION.

**GENERAL NOTES:**

1. GRATINGS OR SIMILAR ACCESSORIES SHALL NOT BE LOCATED IN THE AREA AT THE BASE OF THE CURB RAMP OR LANDING AREA.
2. NO LIP WILL BE PERMITTED AT THE CURB RAMP SLOPE GUTTER PAN. GRINDING SHALL BE 6" MINIMUM PERPENDICULAR TO FLOWLINE FOR RETROFIT.
3. PLANTMIX BITUMINOUS OPEN-GRADED SURFACE SHALL BE FLUSH WITH THE EDGE OF THE GUTTER PAN IN THE AREA OF THE CURB RAMP. GRINDING WIDTH 9" MINIMUM OR 12:1 PLANTMIX BITUMINOUS SURFACE MINIMUM RETROFIT.
4. ROUGH BROOM TEXTURE ON CURB RAMPS AND WINGS. TEXTURE SHALL PROVIDE A VISUAL CONTRAST TO THE SIDEWALK.
5. ALL RAMPS SHALL BE 12:1 OR FLATTER.
6. ALL SLOPE RATES ARE RELATIVE TO LEVEL.
7. IF THERE ARE R/W RESTRICTIONS, SIDEWALK WIDTHS MAY BE REDUCED TO 4'-0" WITH PRIOR APPROVAL PROJECT ENGINEER. IN THESE INSTANCES A 5'-0" PASSING ZONE IS REQUIRED EVERY 200'-0" PER ADA APPENDIX C, SECTION 4.3.4.
8. CONCRETE SHALL BE CLASS A OR AA.
9. ADJUST FLOWLINE WHEN REQUIRED TO PREVENT PONDING AT THE RAMP AND MAINTAIN POSITIVE DRAINAGE.
10. DETECTABLE WARNING SHALL BE CONSTRUCTED WITH STAMPED AND COLORED CONCRETE USING ADA TRUNCATED DOME PATTERN AND CONFORMING TO ADAAG (4.29.2) "CONTRAST".

BRIAN HEAD TOWN

SIDEWALK RAMP AT CORNER LANDING  
AT STREET LEVEL

STANDARD DWG. NO.

109 1 OF 1

APPROVED:

DATE: BY: LBB

REVISIONS

DATE	DESCRIPTION	BY

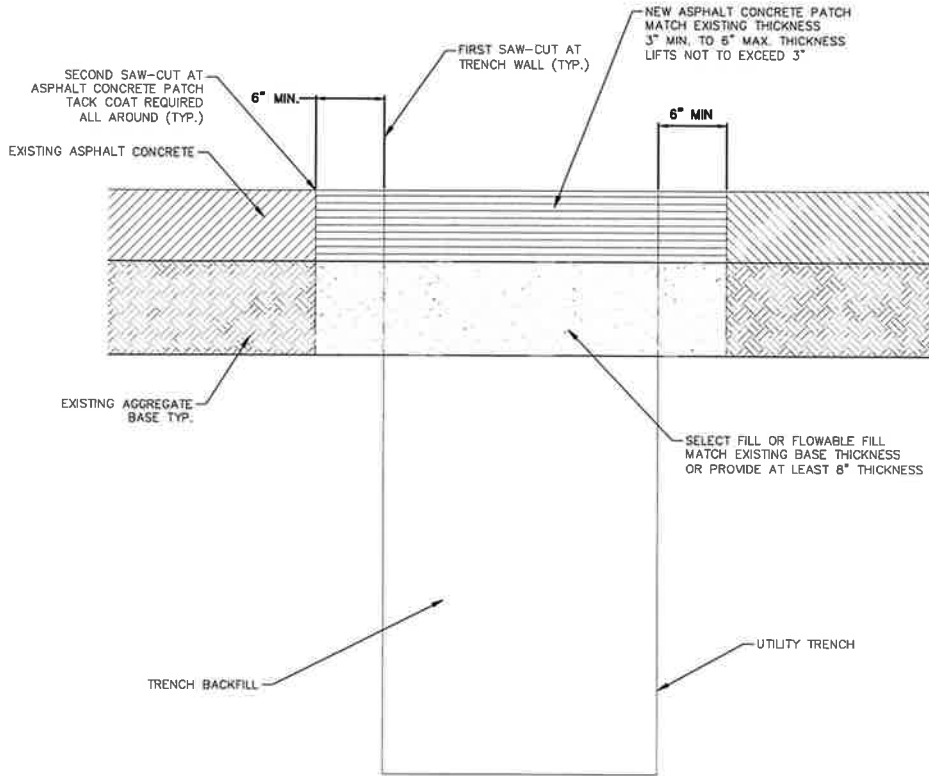

NOTE: THE ABOVE DESIGN IS FOR REFERENCE ONLY. A ROAD CUT PERMIT IS REQUIRED. FINAL SPECIFICATIONS SHALL BE DETERMINED BY ROAD CUT PERMIT.

BRIAN HEAD TOWN

REVISIONS		
DATE	DESCRIPTION	BY

TEMPORARY ASPHALT PATCH  
CONCRETE "T" PATCH

STANDARD DWG. NO.	
110	1 OF 1
APPROVED:	
DATE:	BY: LBB

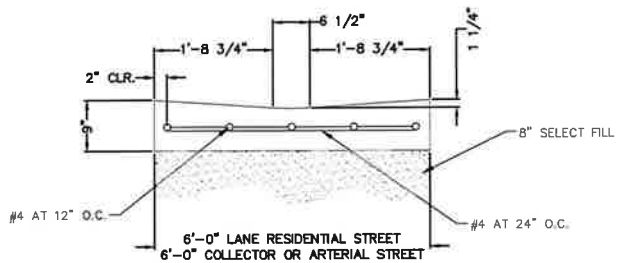
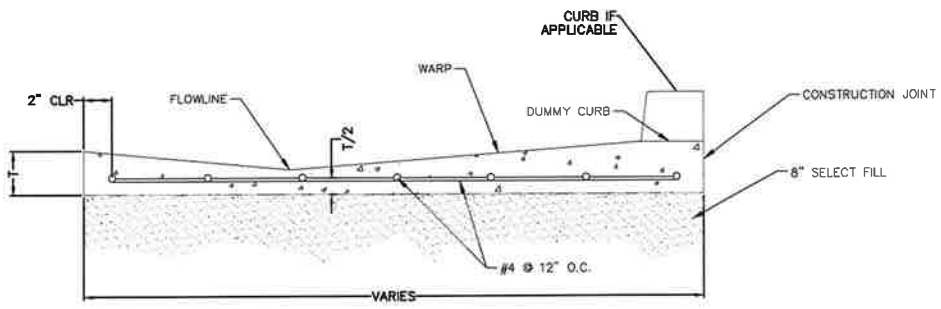
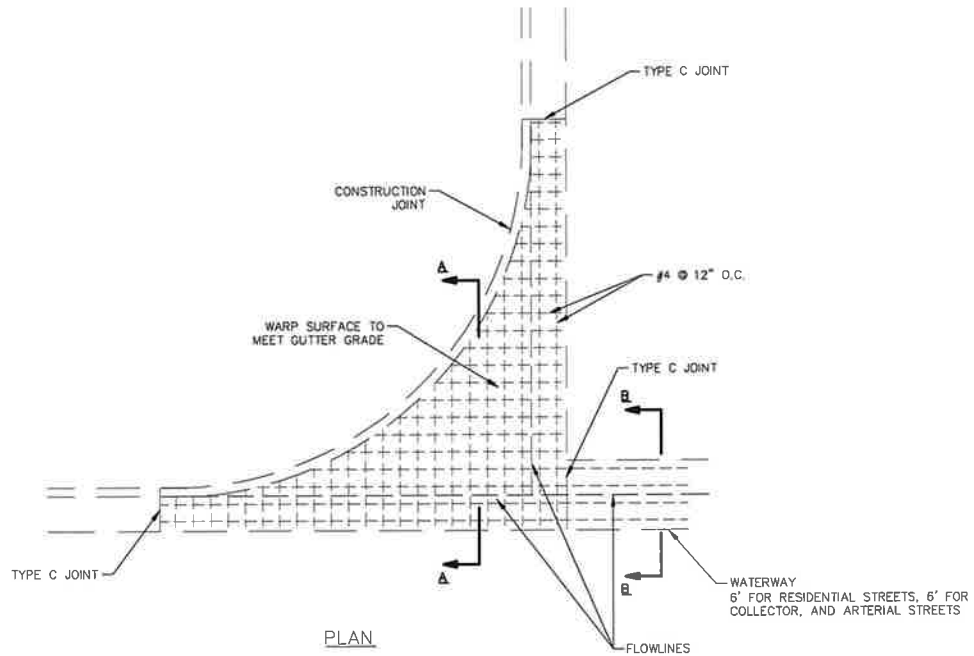

BRIAN HEAD TOWN

WATER TRANSITION STRUCTURE

REVISIONS		
DATE	DESCRIPTION	BY

STANDARD DWG. NO.	
111	1 OF 1
APPROVED:	
DATE:	BY: LBB

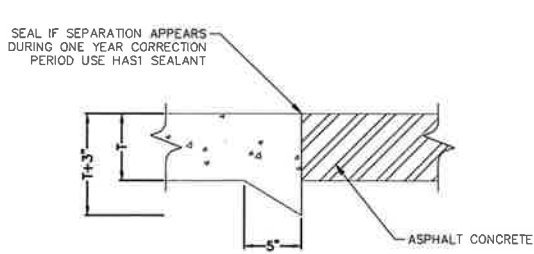

TYPE A JOINT

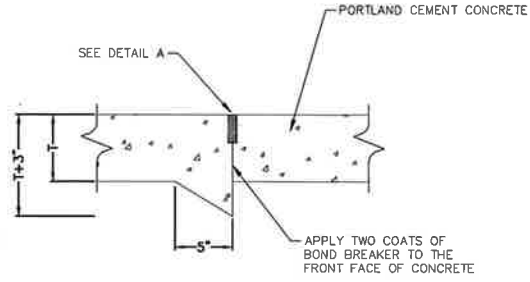

TYPE B JOINT

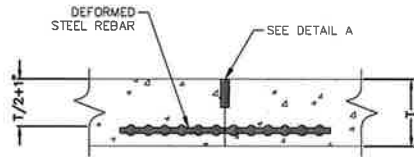

TYPE C JOINT

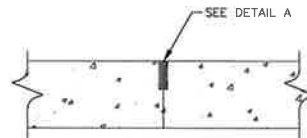

TYPE D JOINT

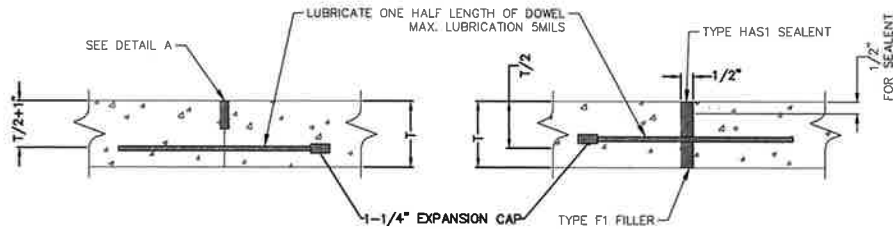

TYPE E JOINT

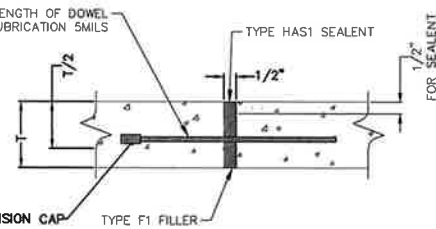

TYPE F JOINT

TABLE OF DIMENSIONS			
T = SLAB DEPTH IN.	DOWEL DIAMETER IN.	TOTAL DOWEL LENGTH IN.	SPACING
5-8	5/8	14	12" O.C.
9-12	1	18	12" O.C.

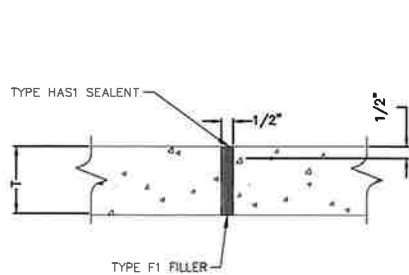

TYPE G JOINT

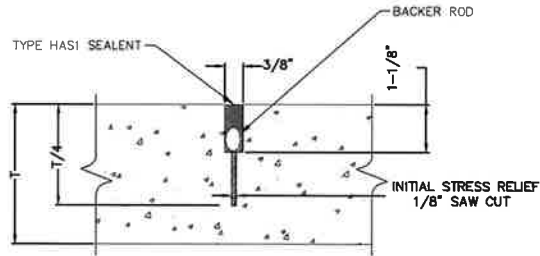

DETAIL A

BRIAN HEAD TOWN

CONCRETE PAVEMENT JOINTS

REVISIONS		
DATE	DESCRIPTION	BY

STANDARD DWG. NO.	
112	1 OF 1
APPROVED:	
DATE:	BY: LBB

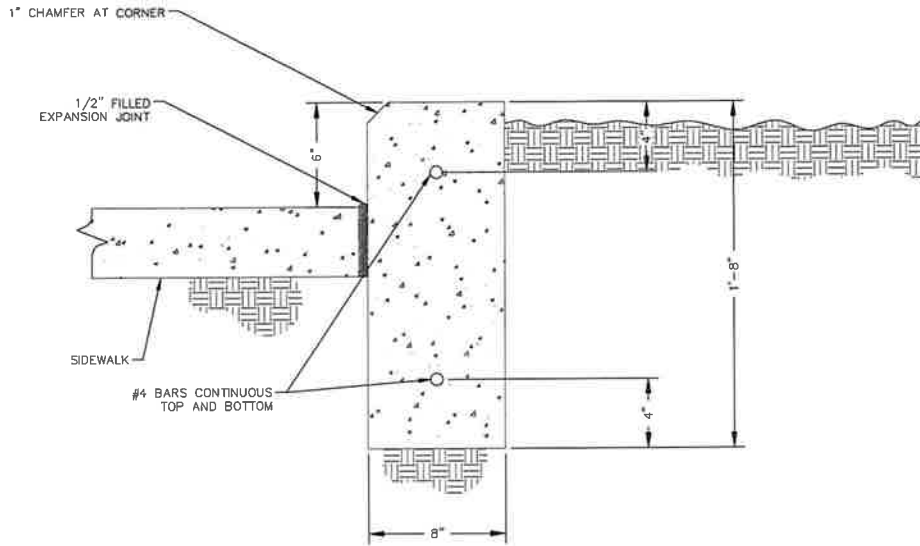

NOTE: ALL EXPOSED CONCRETE SURFACE  
TO HAVE RUBBED FINISH

BRIAN HEAD TOWN

REINFORCED CONCRETE CURB WALL

STANDARD DWG. NO.

113 1 OF 1

APPROVED:

DATE: BY: LBB

REVISIONS		
DATE	DESCRIPTION	BY

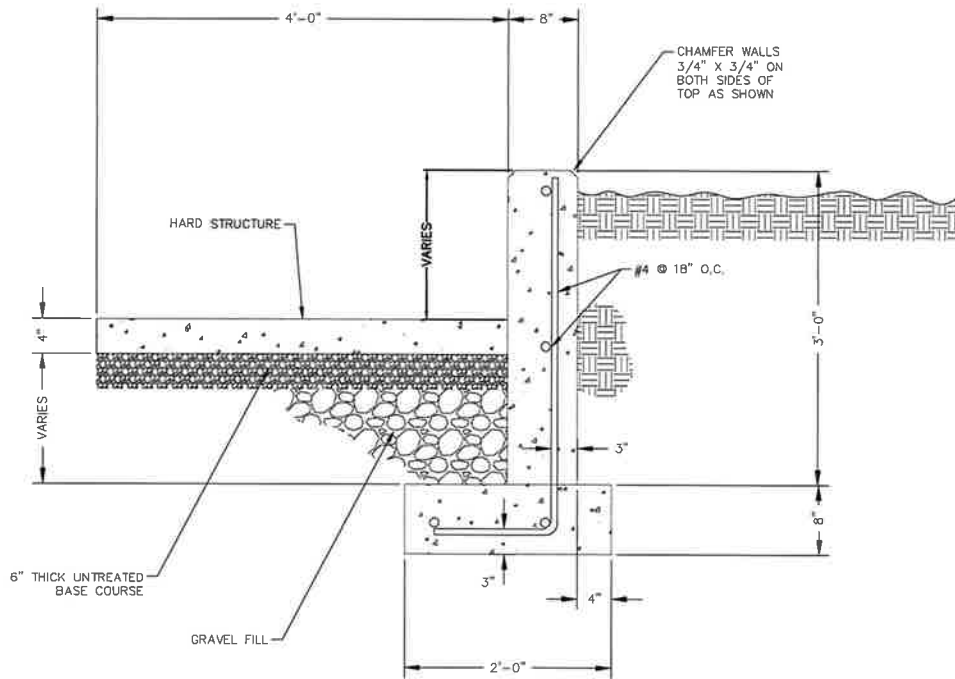

- NOTE:**
1. ALL EXPOSED CONCRETE SURFACE TO HAVE RUBBED FINISH.
  2. WALL TO CONTAIN 0.125 CU. YARDS OF CONCRETE PER FOOT, 6.6 LBS. REINFORCED STEEL PER FOOT.

BRIAN HEAD TOWN

36" CONCRETE RETAINING WALL

STANDARD DWG. NO.

114 | 1 OF 1

APPROVED:

DATE:

BY: LBB

REVISIONS		
DATE	DESCRIPTION	BY

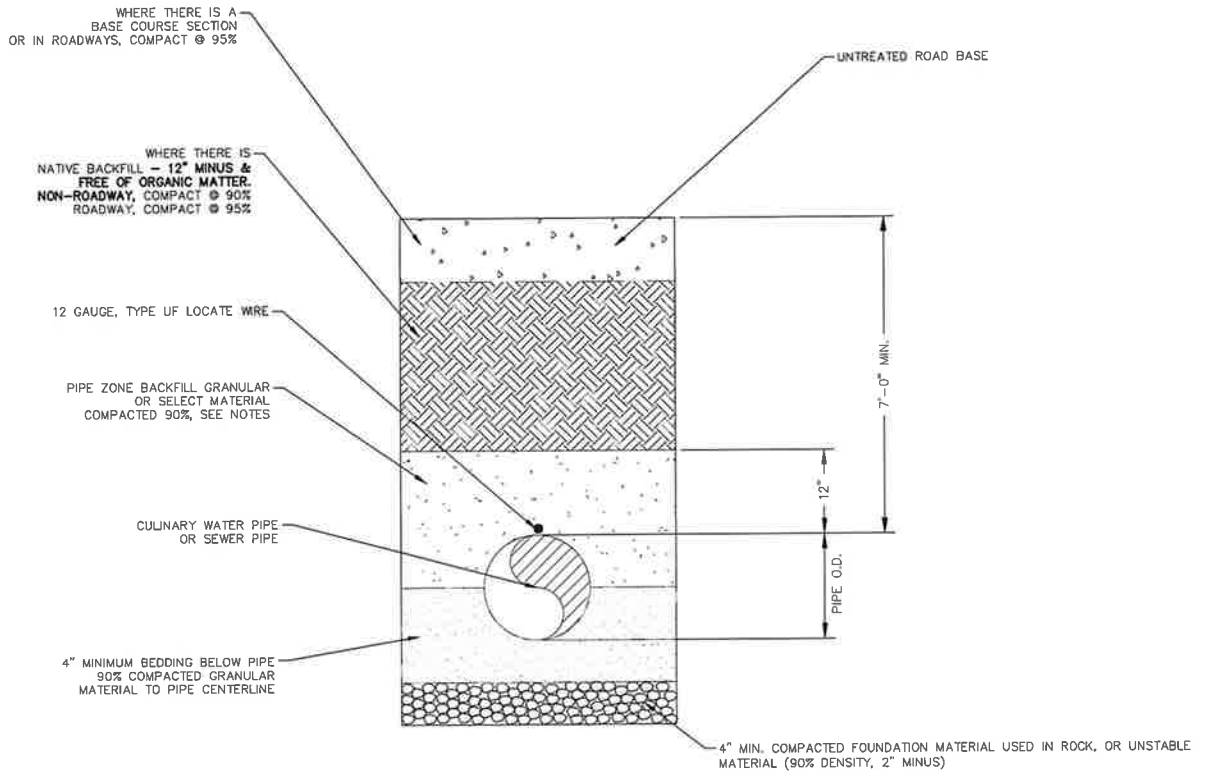

**NOTES:**

1. GRANULAR MATERIALS ARE DEFINED PER THE AASHTO SOIL CLASSIFICATION SYSTEM (ASTM D3282) OR THE UNIFIED SOIL CLASSIFICATION SYSTEM (ASTM D2487), WITH THE EXCEPTION THAT GRAVEL BEDDING/BACKFILL ADJACENT TO THE PIPE IS LIMITED TO 2" MAXIMUM PARTICLE SIZE PER ANSI/AWWA C600.
2. "SELECT MATERIAL" IS DEFINED AS NATIVE SOIL EXCAVATED FROM THE TRENCH, FREE OF ROCKS, FOREIGN MATERIAL, AND FROZEN EARTH.

BRIAN HEAD TOWN

REVISIONS		
DATE	DESCRIPTION	BY

APPENDIX A - STANDARD DRAWINGS  
TYPICAL TRENCH DETAIL

STANDARD DWG. NO.	
115	1 OF 1
APPROVED:	
DATE:	BY: LBB

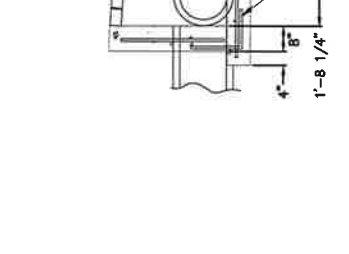
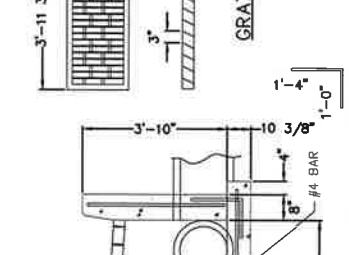
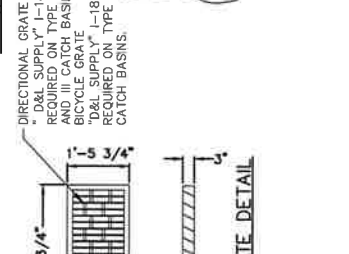
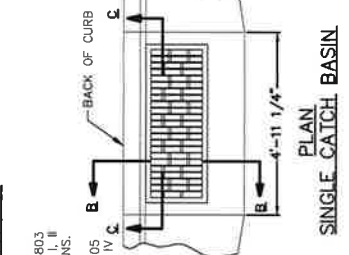
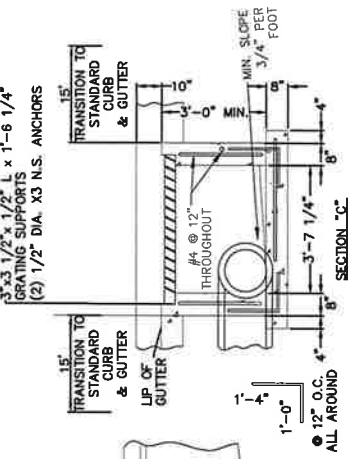
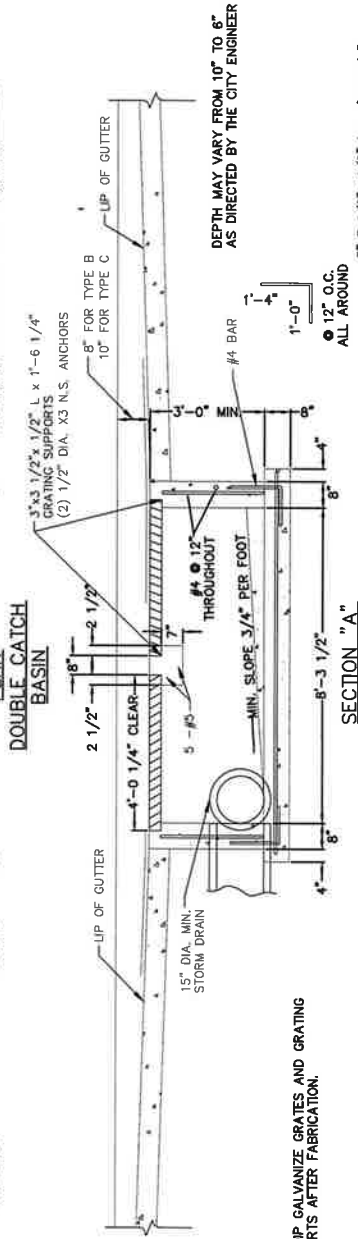
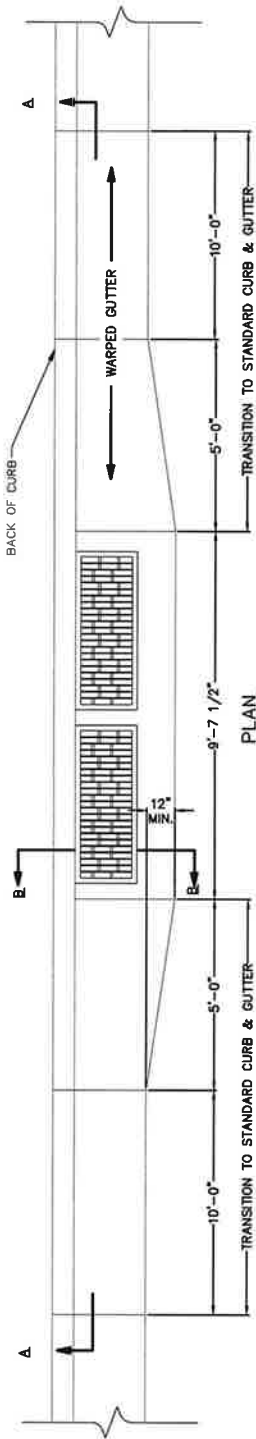

NOTE:  
1. HOT DIP GALVANIZE GRATES AND GRATING  
SUPPORTS AFTER FABRICATION.

DIRECTIONAL GRATE  
\* D&L SUPPLY 1-1803  
REQUIRED ON TYPE I, II  
AND III CATCH BASINS.  
BICYCLE GRATE  
D&L SUPPLY 1-1805  
REQUIRED ON TYPE IV C  
CATCH BASINS.

DEPTH MAY VARY FROM 10" TO 6"  
AS DIRECTED BY THE CITY ENGINEER

STANDARD ROADWAY SECTION

BRIAN HEAD TOWN

CATCH BASIN-SINGLE & DOUBLE GRATE  
FOR ROLL CURB AND GUTTER

REVISIONS		
DATE	DESCRIPTION	BY

STANDARD DWG. NO.	
204	1 OF 1
APPROVED:	
DATE:	BY: LBB

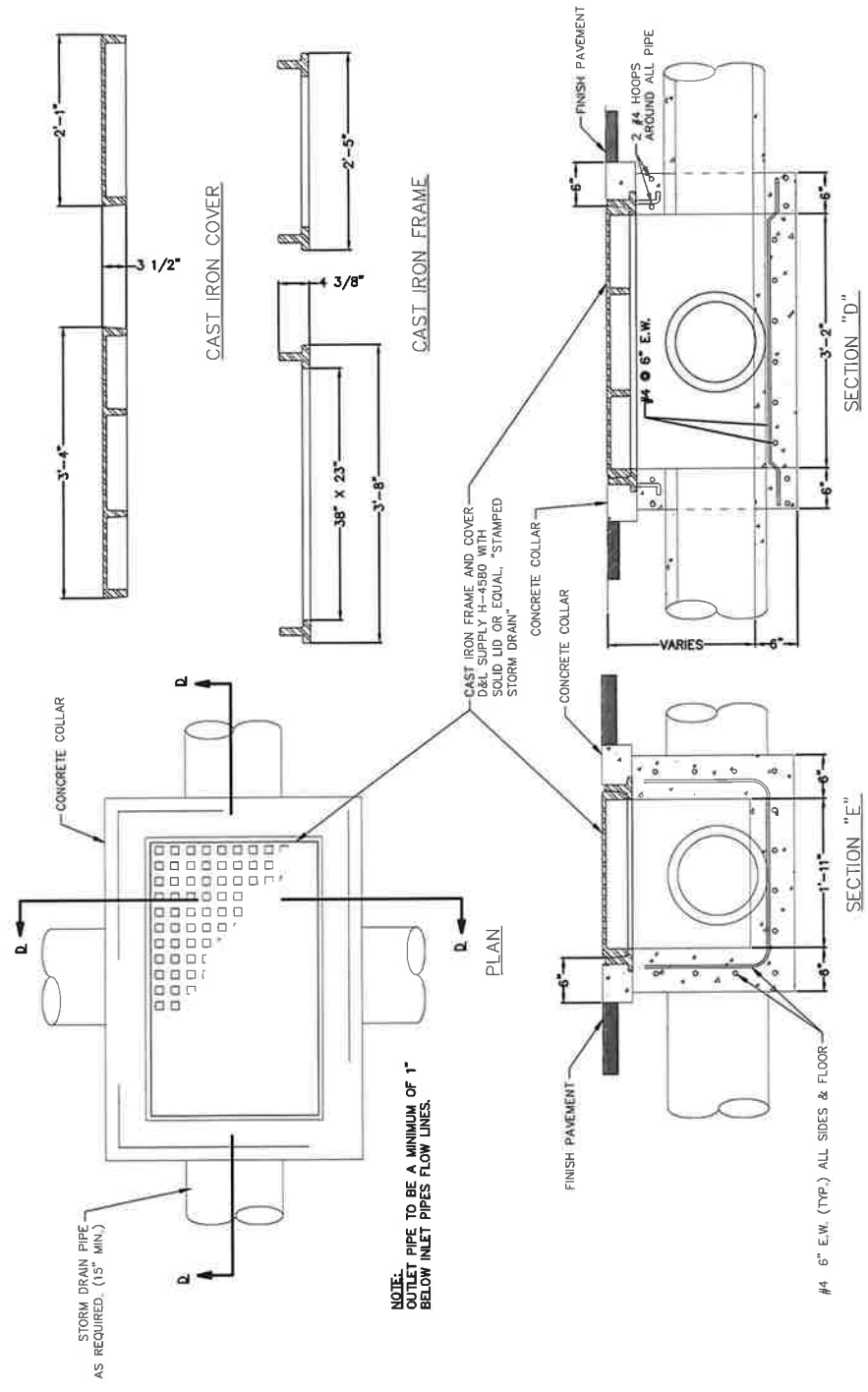

NOTE:  
 OUTLET PIPE TO BE A MINIMUM OF 1"  
 BELOW INLET PIPES FLOW LINES.

BRIAN HEAD TOWN

RECTANGULAR STORM DRAIN CLEANOUT

STANDARD DWG. NO.  
 206 1 OF 1

REVISIONS		
DATE	DESCRIPTION	BY

APPROVED:  
 DATE: BY: LBB

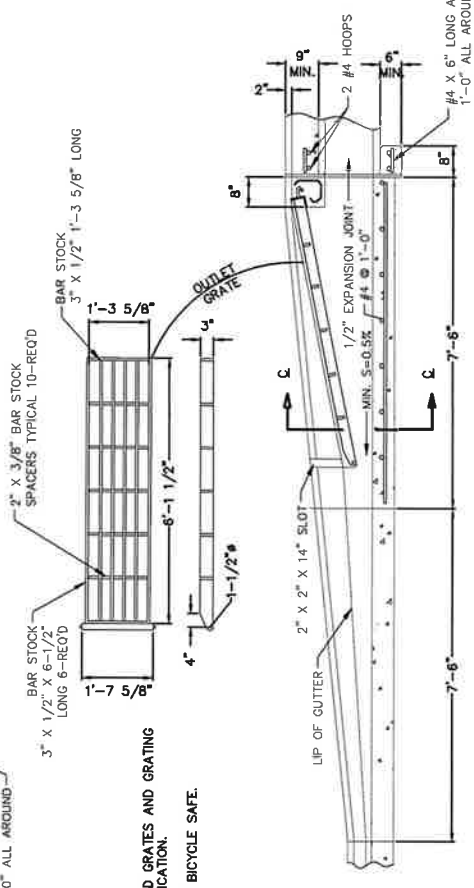
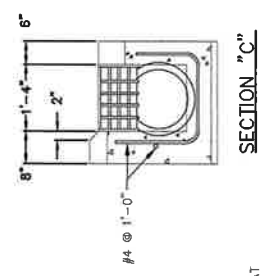
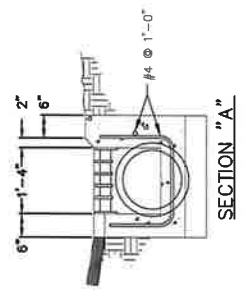
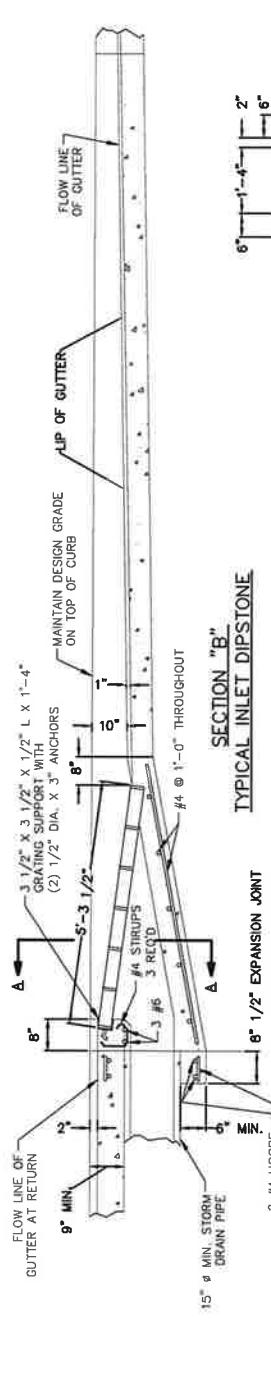
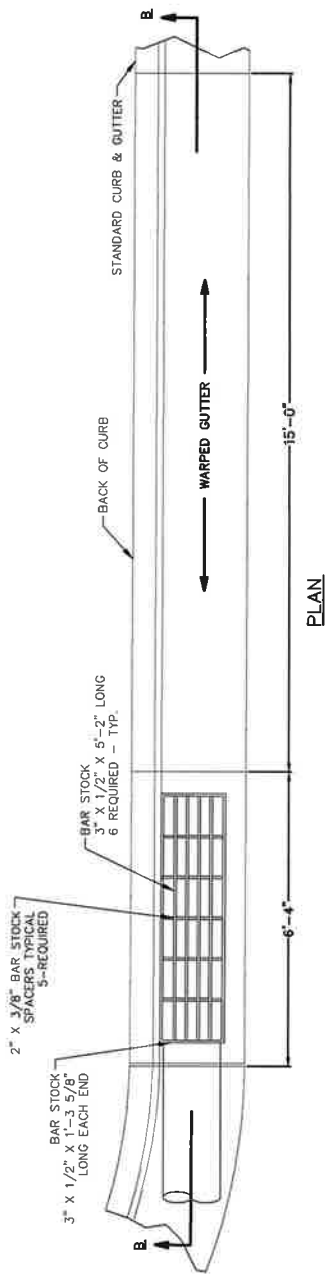

NOTE:  
 (1) HOT DIP GALVANIZED GRATES AND GRATING SUPPORTS AFTER FABRICATION.  
 (2) ALL GRATES TO BE BICYCLE SAFE.

BRIAN HEAD TOWN  
 DIPSTONE

REVISIONS		
DATE	DESCRIPTION	BY

STANDARD DWG. NO.	
207	1 OF 1
APPROVED:	
DATE:	BY: LBB

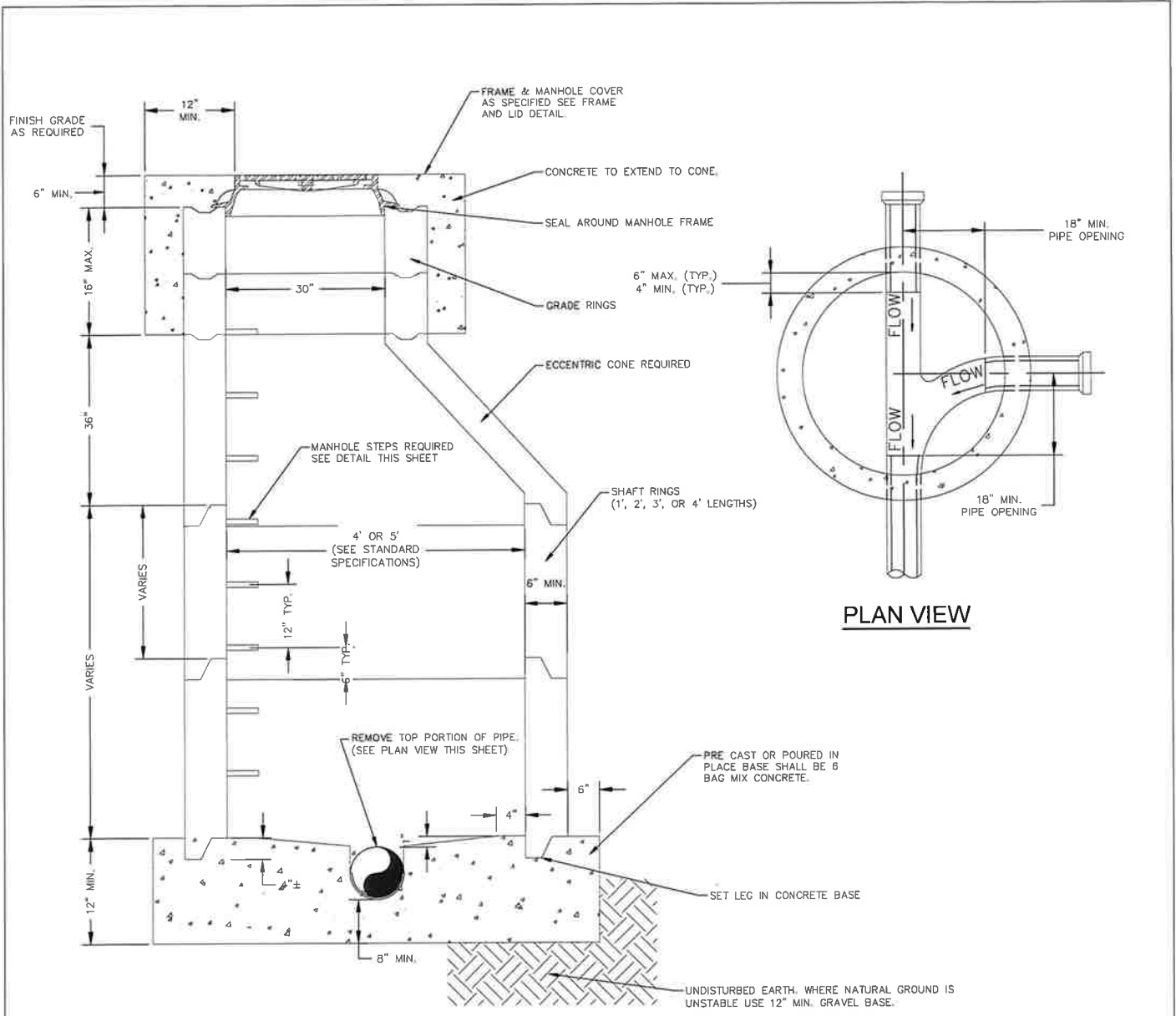

**SEWER MANHOLE**

**NOTE:**  
 1- SEE DRAWING NO. 221 FOR JUNCTION AND DROP MANHOLE DETAILS AND MANHOLE SIZES.  
 2- PRECAST MAY BE USED, BUT REQUIRES ADVANCED APPROVAL.  
 3- IF OPTIONAL JOINT USED, ALL MANHOLE SECTIONS SHALL BE CLEARLY MARKED ON THE INSIDE AS TO THE MANUFACTURER AND TYPE OF JOINT BEING USED.

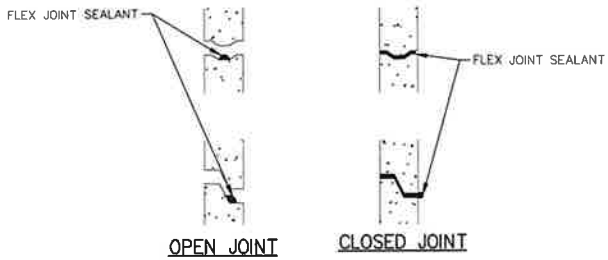

**JOINT DETAILS**

BRIAN HEAD TOWN  
 STANDARD MANHOLE  
 DETAILS

REVISIONS		
DATE	DESCRIPTION	BY

STANDARD DWG. NO.	
300	1 OF 1
APPROVED:	
DATE:	BY: LBB

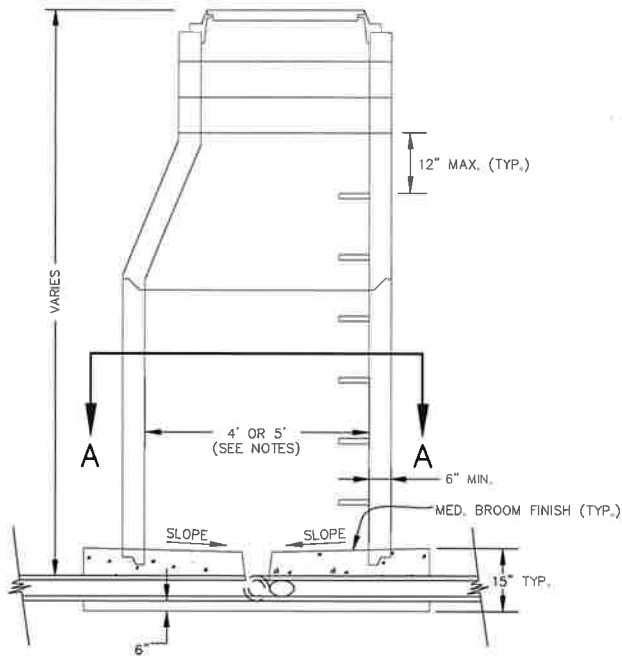

**TYPICAL JUNCTION MANHOLE**  
(SECTION THRU CENTER)

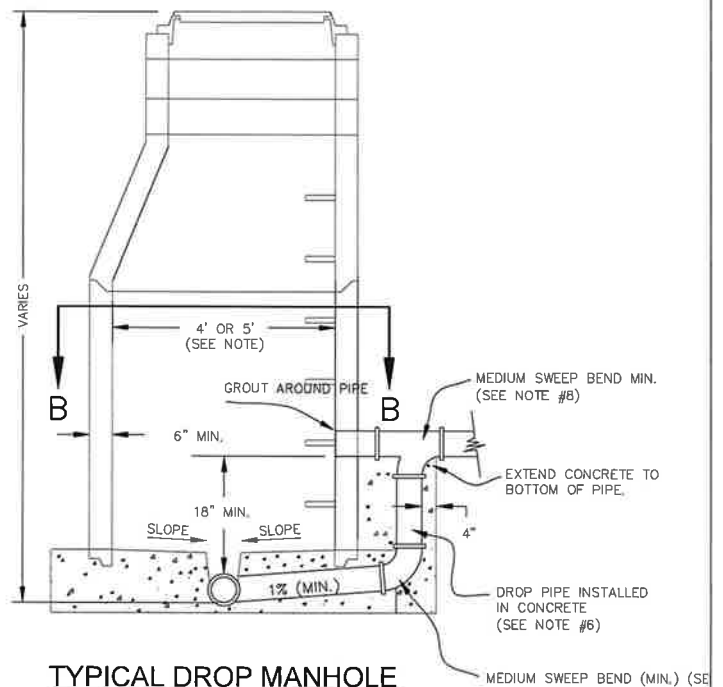

**TYPICAL DROP MANHOLE**  
(SECTION THRU CENTER)

**NOTES:**

- 1- FOR SEWER PIPES LESS THAN 12-INCH DIAMETER USE 4-FOOT DIAMETER MANHOLE.
- 2- FOR SEWER PIPES WITH 12-INCH OR GREATER DIAMETER USE 5-FOOT DIAMETER MANHOLE.
- 3- WHEN THE SUM OF ALL PIPE SIZES CONNECTED TO THE MANHOLE TOTALS 24 INCHES OR GREATER USE A 5-FOOT DIAMETER MANHOLE.
- 4- WHEN SEWER DEPTH IS 12 FEET OR GREATER USE A 5-FOOT DIAMETER MANHOLE.
- 5- SEE DRAWING NO. 220 FOR ADDITIONAL DETAILS.
- 6- VERTICAL DROP PIPE AND FITTINGS SHALL BE THE SAME SIZE AS THE INCOMING SEWER PIPE.
- 7- NO LATERALS SHALL BE INSTALLED DIRECTLY INTO MANHOLES UNLESS PRIOR APPROVAL BY CITY REPRESENTATIVE.
- 8- BENDS CAN BE 45° OR 90° - (90° IS SHOWN) ALL OTHER REQUIREMENTS ARE THE SAME.

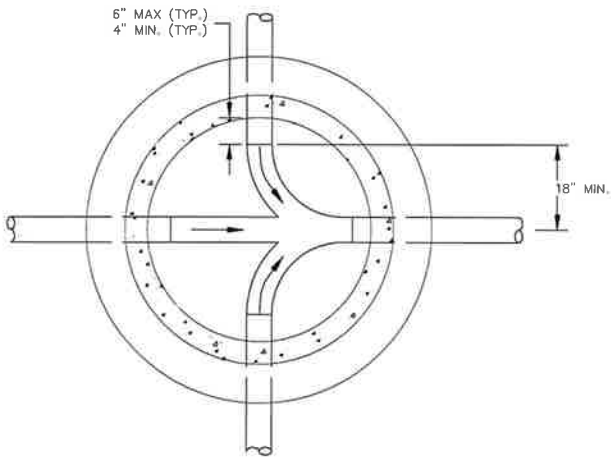

**SECTION A-A**

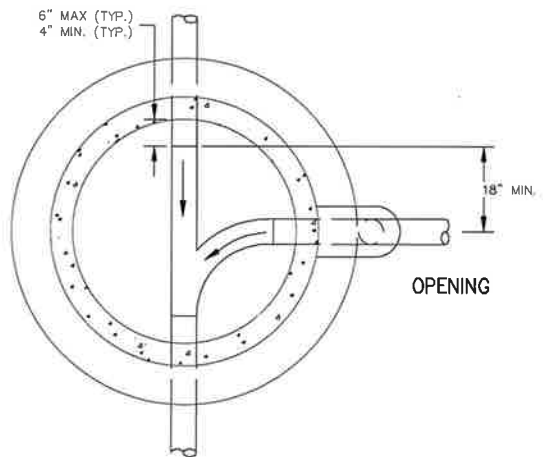

**SECTION B-B**

BRIAN HEAD TOWN

JUNCTION & DROP MANHOLE  
DETAILS

REVISIONS		
DATE	DESCRIPTION	BY

STANDARD DWG. NO.	
301	1 OF 1
APPROVED:	
DATE:	BY: LBB

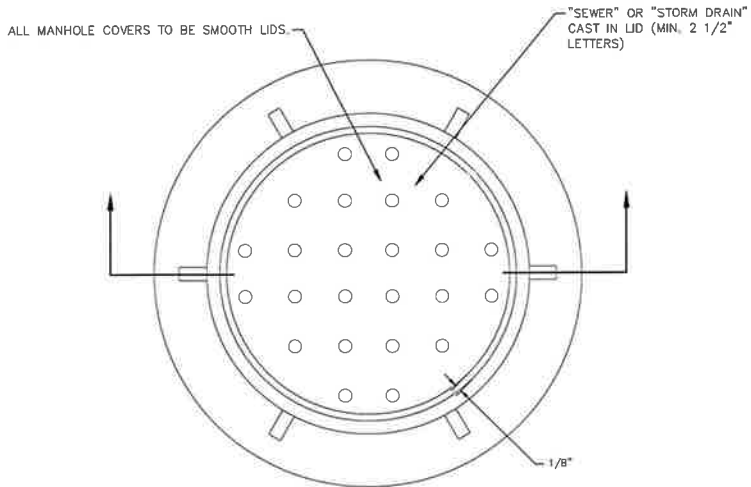

**PLAN OF COVER & FRAME**

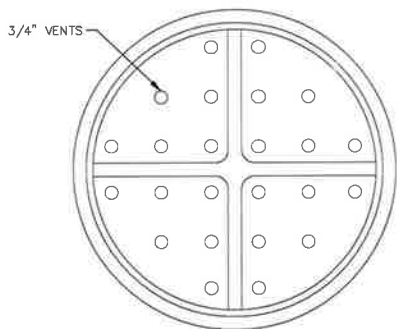

**BOTTOM VIEW OF COVER**

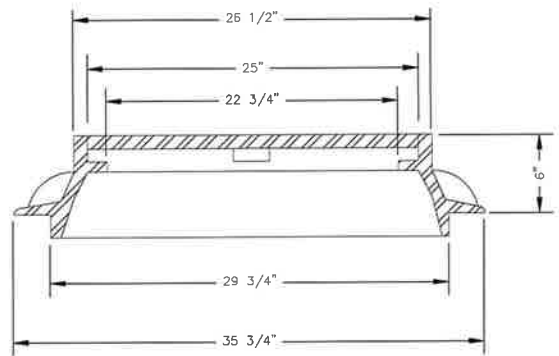
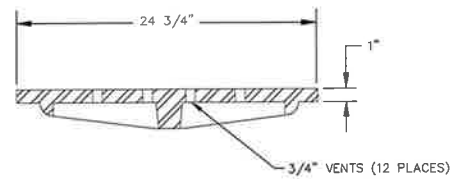

**SECTION 1**

**NOTE: CAST IRON FRAME & COVER TO MEET REQUIREMENTS OF ASTM A 48 (CLASS 30) REQUIRED MINIMUM COMBINED WEIGHT 402 lbs.**

**BRIAN HEAD TOWN**

REVISIONS		
DATE	DESCRIPTION	BY

**MANHOLE FRAME & COVER  
DETAILS**

STANDARD DWG. NO.	
302	1 OF 1
APPROVED:	
DATE:	BY: LBB

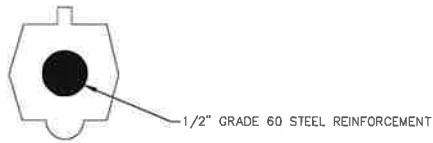

SECTION A-A

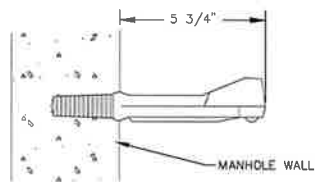
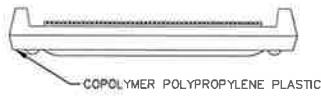
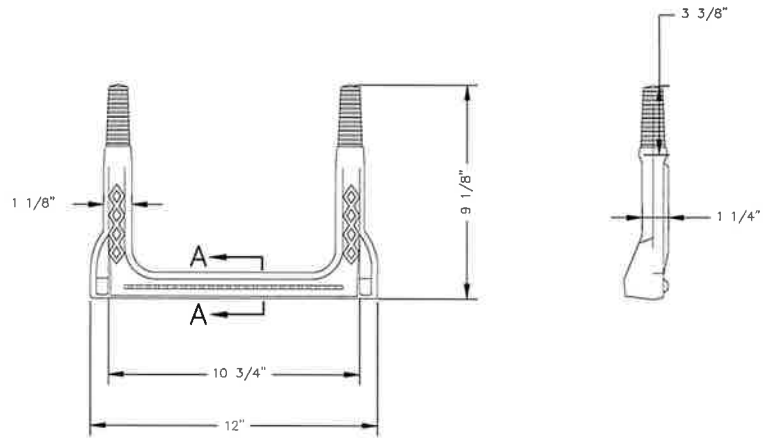

REVISIONS		
DATE	DESCRIPTION	BY

BRIAN HEAD TOWN  
 MANHOLE STEP DETAIL  
 DETAILS

STANDARD DWG. NO.	
303	1 OF 1
APPROVED:	
DATE:	BY: LBB

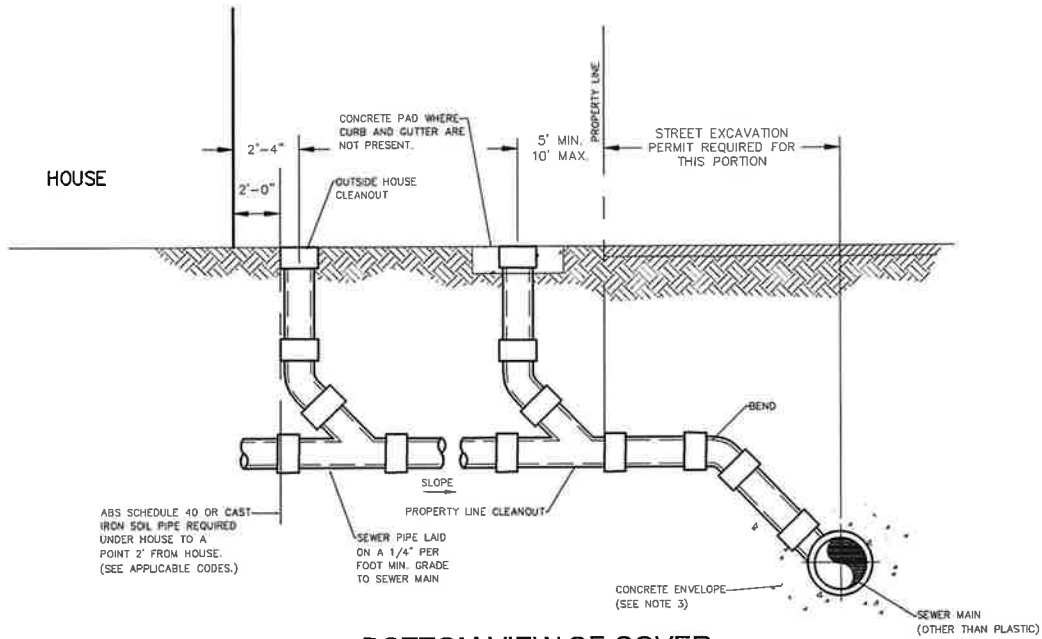

**BOTTOM VIEW OF COVER**

**NOTES:**

1- PROPERTY LINE AND OUTSIDE HOUSE CLEANOUTS ARE REQUIRED AS SHOWN.

2- CLEANOUT REQUIRED AT 100' MAX. SPACING (STRAIGHT RUNS) AND FOR EACH AGGREGATE CHANGE IN DIRECTION, WHERE TOTAL AGGREGATE CHANGE EXCEEDS 135 DEGREES.

3- ALL LATERALS CUT INTO EXISTING MAINS SHALL BE ADAPTED WITH SADDLES. WHERE SADDLES ARE NOT WATER TIGHT, A CONCRETE ENVELOPE SHALL BE REQUIRED. LATERALS SHALL NOT PROTRUDE INTO SEWER MAINS.

4- ALL CLEANOUTS LOCATED IN DRIVEWAYS OR OTHER AREAS SUBJECT TO VEHICLE TRAFFIC SHALL HAVE A CAST IRON RING AND COVER OR OTHER APPROVED PROTECTIVE DEVICE.

5- FOR COMMERCIAL APPLICATION CONTACT WASTE WATER DEPARTMENT.

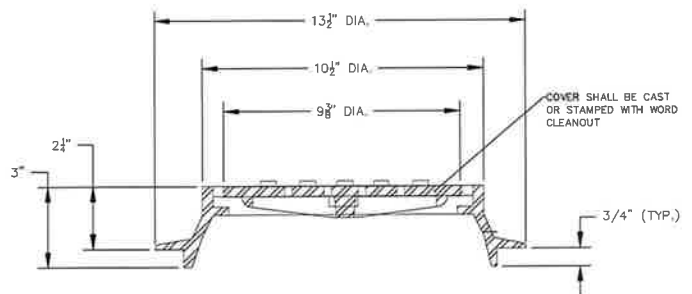

**STANDARD CLEANOUT RING & LID  
(H-20 RATING)**

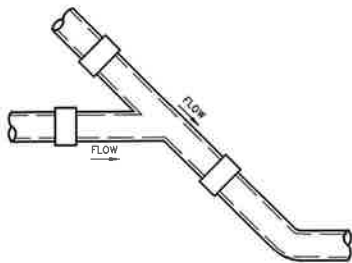

**DETAIL - DROP C.O.  
(WHERE REQUIRED)**

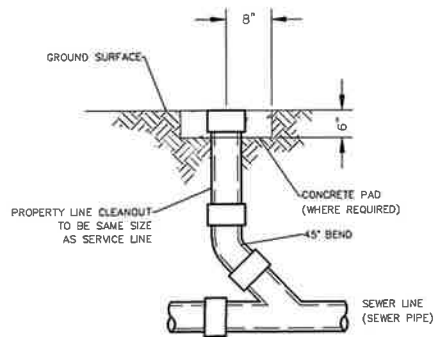

**BOTTOM VIEW OF COVER**

BRIAN HEAD TOWN

**TYPICAL RESIDENTIAL SEWER CONNECTION  
DETAILS**

STANDARD DWG. NO.

304 1 OF 1

APPROVED:

DATE: BY: LBB

REVISIONS		
DATE	DESCRIPTION	BY

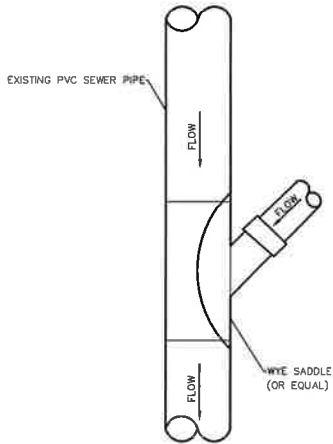
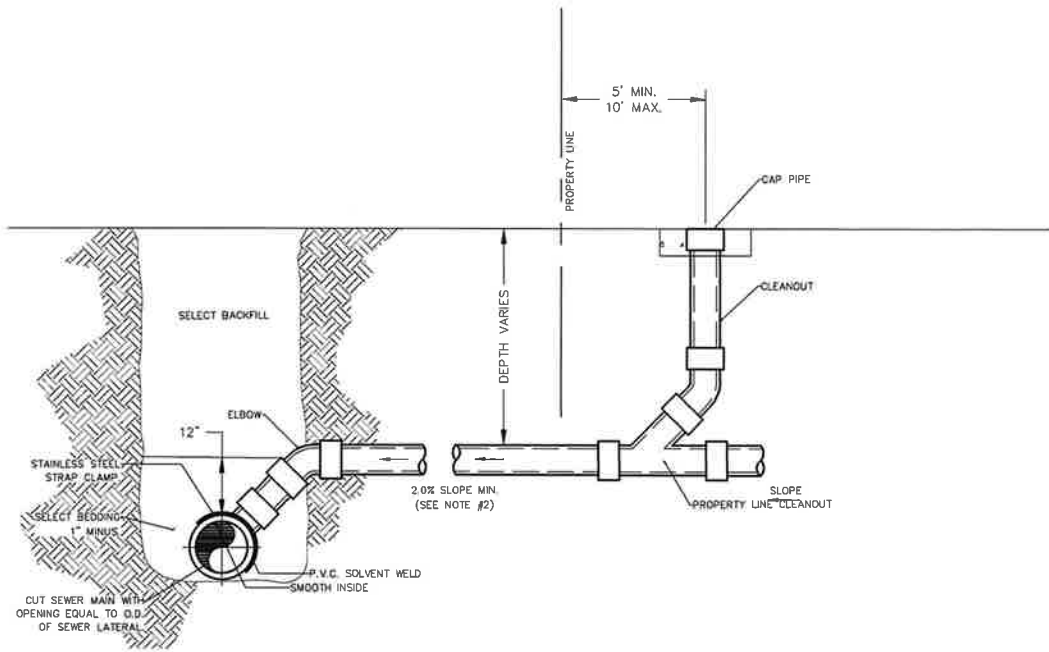

- NOTES:
- 1- BACKFILL AND COMPACTION REQUIREMENTS SHALL CONFORM TO CITY STANDARD SPECIFICATIONS, SPECIFICATIONS.
  - 2- 4" DIAMETER- 2% MINIMUM / 6" DIAMETER- 1% MINIMUM
  - 3- CLEANOUT DIAMETER TO BE SAME SIZE AS LATERAL
  - 4- INSTALL WYE SADDLE PER MANUFACTURERS RECOMMENDATIONS

BRIAN HEAD TOWN

REVISIONS		
DATE	DESCRIPTION	BY

P.V.C. SERVICE CONNECTION  
EXISTING P.V.C. SEWER MAINS

STANDARD DWG. NO.	
305	1 OF 1
APPROVED:	
DATE:	BY: LBB

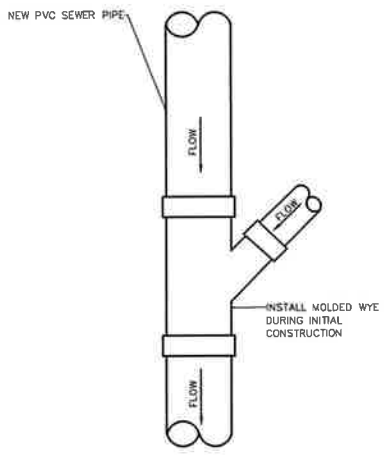
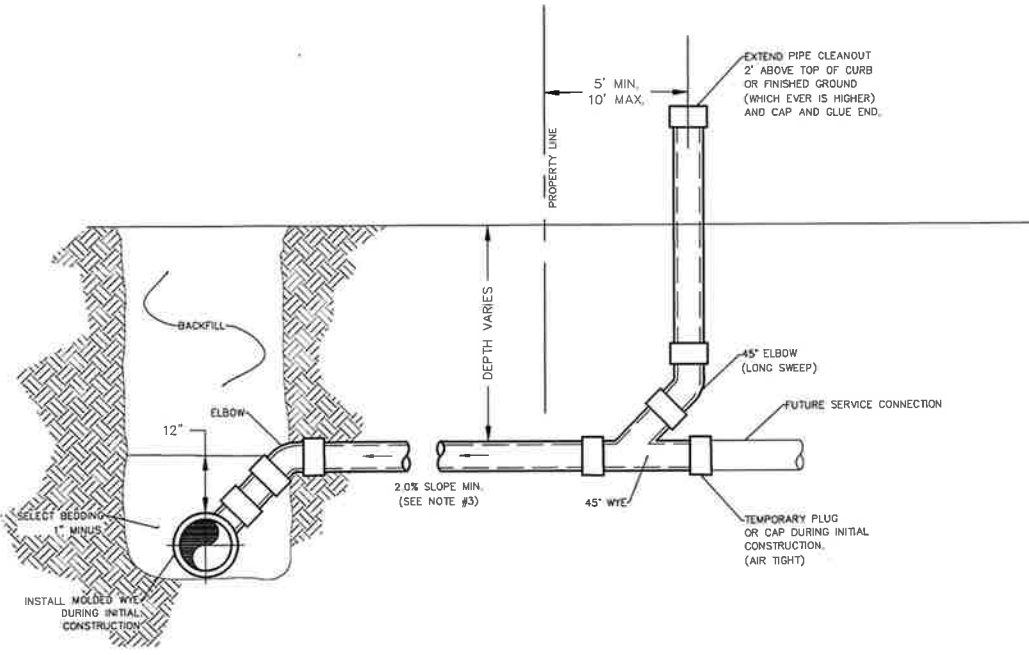

- NOTES:**
- 1- DURING INITIAL SEWER INSTALLATION CLEANOUT SHALL EXTEND AS SHOWN. AFTER HOME CONSTRUCTION CLEANOUT SHALL BE ADJUSTED TO GRADE.
  - 2- BACKFILL AND COMPACTION REQUIREMENTS SHALL CONFORM TO CITY STANDARD SPECIFICATIONS, SPECIFICATIONS.
  - 3- 4" DIAMETER- 2% MINIMUM./ 6" DIAMETER- 1% MINIMUM.
  - 4- CLEANOUT DIAMETER TO BE SAME SIZE AS LATERAL.
  - 5- BRASS PLUG MARKED WITH "S" PLACED IN TOP OF CURB MAY BE USED IN LIEU OF INSCRIBED "S" IN FACE.

BRIAN HEAD TOWN

REVISIONS		
DATE	DESCRIPTION	BY

P.V.C. SERVICE CONNECTION  
NEW P.V.C. SEWER MAINS

STANDARD DWG. NO.	
306	1 OF 1
APPROVED:	
DATE:	BY: LBB

24-3/4" DIA. D&L SUPPLY  
E-1925 LOCK  
BOLT/NON-VENTED MANHOLE  
LID OR EQUAL (VAPOR TIGHT)

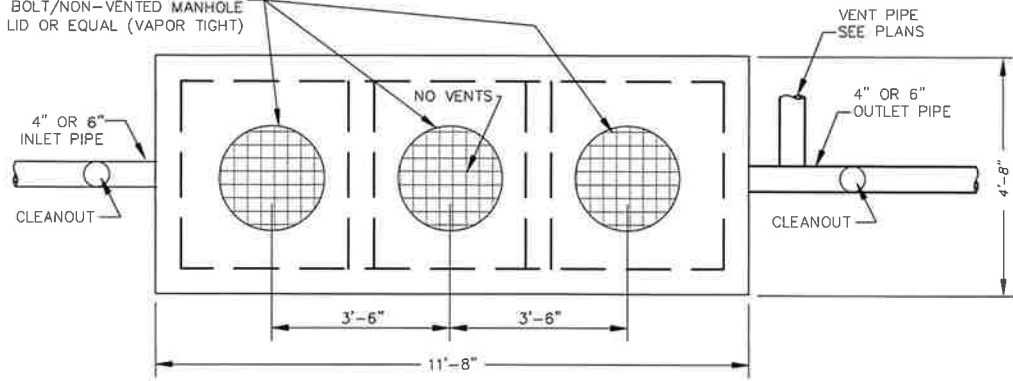

**TOP VIEW**

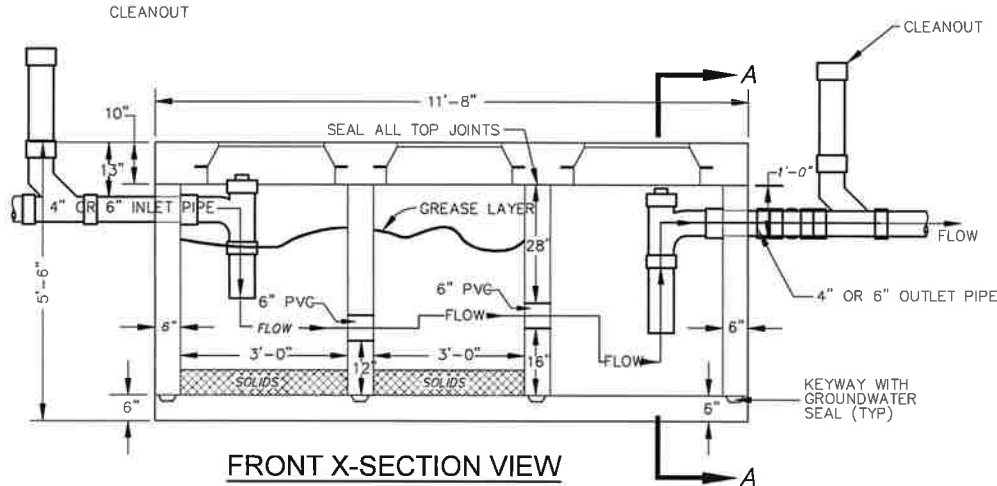

**FRONT X-SECTION VIEW**

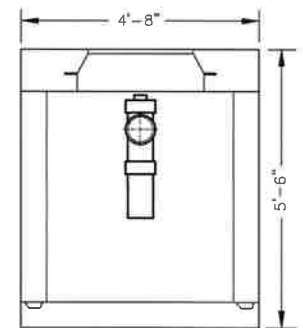

**SIDE X-SECTION A-A**

**NOTES:**

1. MATERIAL SPEC'S:
  - 1.1. CONCRETE PORTLAND CEMENT TYPE II. MINIMUM COMPRESSIVE STRENGTH=3000 PSI AT 28 DAYS.
  - 1.2. REINFORCING BAR INTERMEDIATE GRADE ASTM A615.
  - 1.3. REINFORCING WELDED WIRE MESH ASTM A185
2. UNIT COATED OUTSIDE WITH AN APPROVED PROTECTIVE COATING.
3. ALL DIMENSIONS +/- NOT TO BE USED FOR CONSTRUCTION PURPOSES UNLESS CERTIFIED.
4. PRECAST UNIT TO BE PLACED ON NATURAL SOIL OR APPROVED COMPACTED FILL.
5. STANDARD GROUND WATER SEAL- BUTYL ROPE MASTIC OR CEMENT MORTAR.
6. PRIOR TO BACKFILLING, INTERCEPTOR SHALL BE TESTED. TANK SHALL BE EXPOSED ON ALL SIDES AND FILLED WITH WATER AND SHALL HOLD WATER FOR A MINIMUM TEST PERIOD OF TWO HOURS.
7. CLEANOUT SIZE TO MATCH INLET/OUTLET SIZE.

REVISIONS		
DATE	DESCRIPTION	BY

**BRIAN HEAD TOWN**  
**GREASE INTERCEPTOR**  
**DETAILS**

STANDARD DWG. NO.	
307	1 OF 1
APPROVED:	
DATE:	BY: LBB

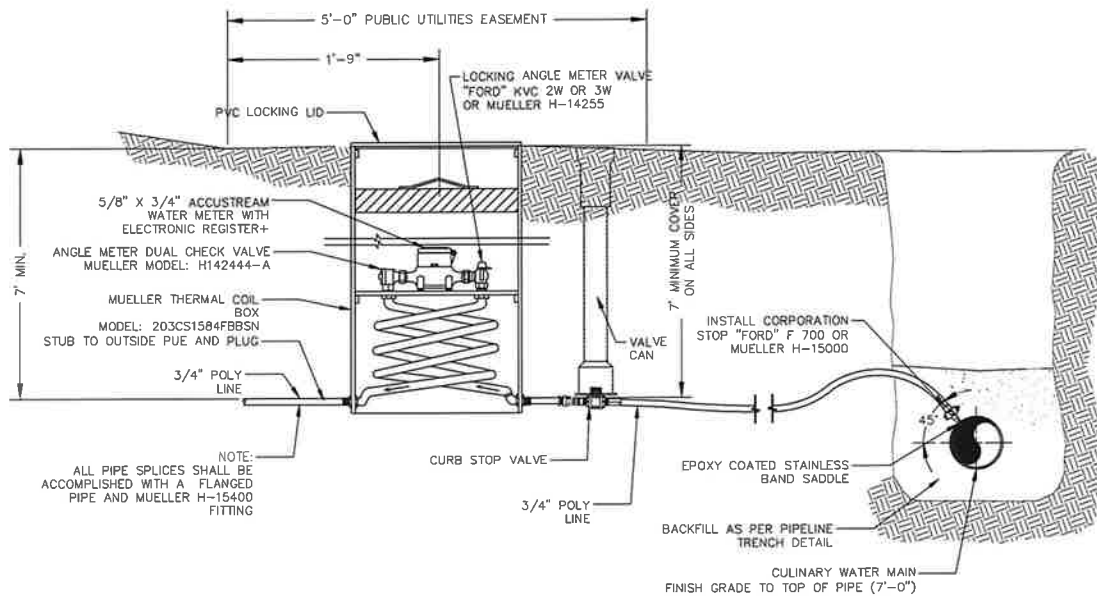

TYPICAL WATER SERVICE INSTALLATION

BRIAN HEAD TOWN

WATER SERVICE  
DETAIL

STANDARD DWG. NO.

401 1 OF 1

APPROVED:

DATE:

BY: LBB

REVISIONS		
DATE	DESCRIPTION	BY

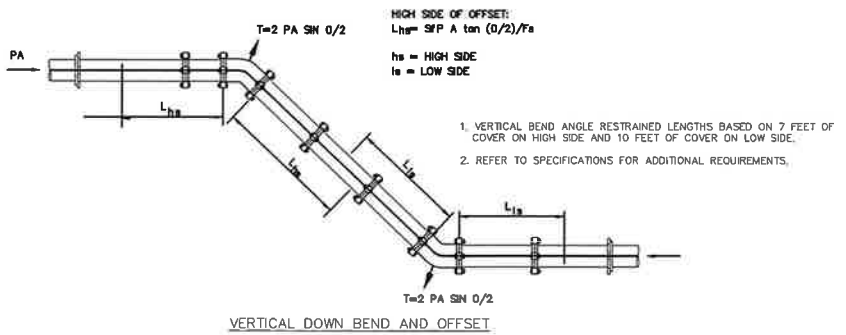

VERTICAL DOWN BEND AND OFFSET

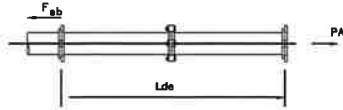

DEAD ENDS TO BE RESTRAINED FOR 27(24\*\*) FEET FOR  $\phi$  D PIPE.

DEAD END

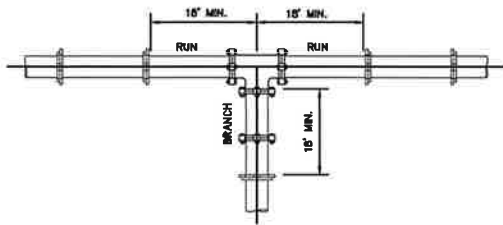

ALL TEES TO BE RESTRAINED 18' MIN

\*\* - ONLY RESTRAIN THE BRANCH OUTLET OF THE TEE.

TEE

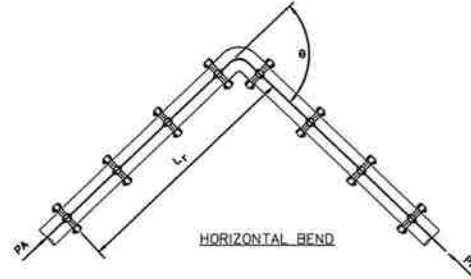

HORIZONTAL BEND

DESIGN DATA:

BASED ON 200 PSI TEST PRESSURE  
 SOIL TYPE= SILTY SAND  
 DEPTH OF BURY 7'-8'  
 TRENCH TYPE #5  
 SAFETY FACTOR = 1.5

NOTES:

- THRUST RESTRAINT PIPE SECTIONS AT BEND LOCATIONS REQUIRE INTERIOR RESTRAINT TYPE DUCTILE IRON PIPE OR EXTERIOR RESTRAINT TYPE DUCTILE IRON PIPE W/ V-BIO POLY WRAP.
- DEFLECTION ANGLES FOR DI PIPE LESS THAN 11.25° (AS SHOWN ON THE PLANS) SHALL BE ACCOMPLISHED BY DEFLECTION OF PIPE JOINTS A MAXIMUM OF 5° FOR EACH 20 FT. LENGTH OF PIPE. THE CURVATURE RADIUS SHALL BE LESS THAN 380 FT.
- ALL FITTINGS, VALVES, BENDS, ETC. ARE TO HAVE JOINT RESTRAINTS AS REQUIRED BY SPECIFICATIONS. THRUST BLOCKS MAY ONLY BE USED WHERE SPECIFICALLY NOTED ON THE PLANS.

Pipe Size	Dead End	Horizontal Bend				Vertical Bend - High Side/Low Side		
		11.25° Bend	22.5° Bend	45° Bend	90° Bend	11.25° Bend	22.5° Bend	45° Bend
4	15	1	2	3	7	2/1	3/1	7/2
6	21	1	2	4	10	3/1	5/2	9/3
8	28	2	3	5	12	3/1	6/2	12/4
10	34	2	3	6	15	4/2	7/3	14/5
12	40	2	4	8	18	4/2	8/3	17/6
14	46	2	4	9	20	5/2	10/3	19/6
16	52	3	5	10	23	6/2	11/4	22/7
18	58	3	5	11	25	6/2	12/4	24/8
20	64	3	6	12	27	7/2	13/4	27/9
24	75	4	7	14	32	8/3	15/5	32/10

BRIAN HEAD TOWN

MEGALUG THRUST RESTRAINT  
 DETAILS

REVISIONS		
DATE	DESCRIPTION	BY

STANDARD DWG. NO.	
402	1 OF 1
APPROVED:	
DATE:	BY: LBB

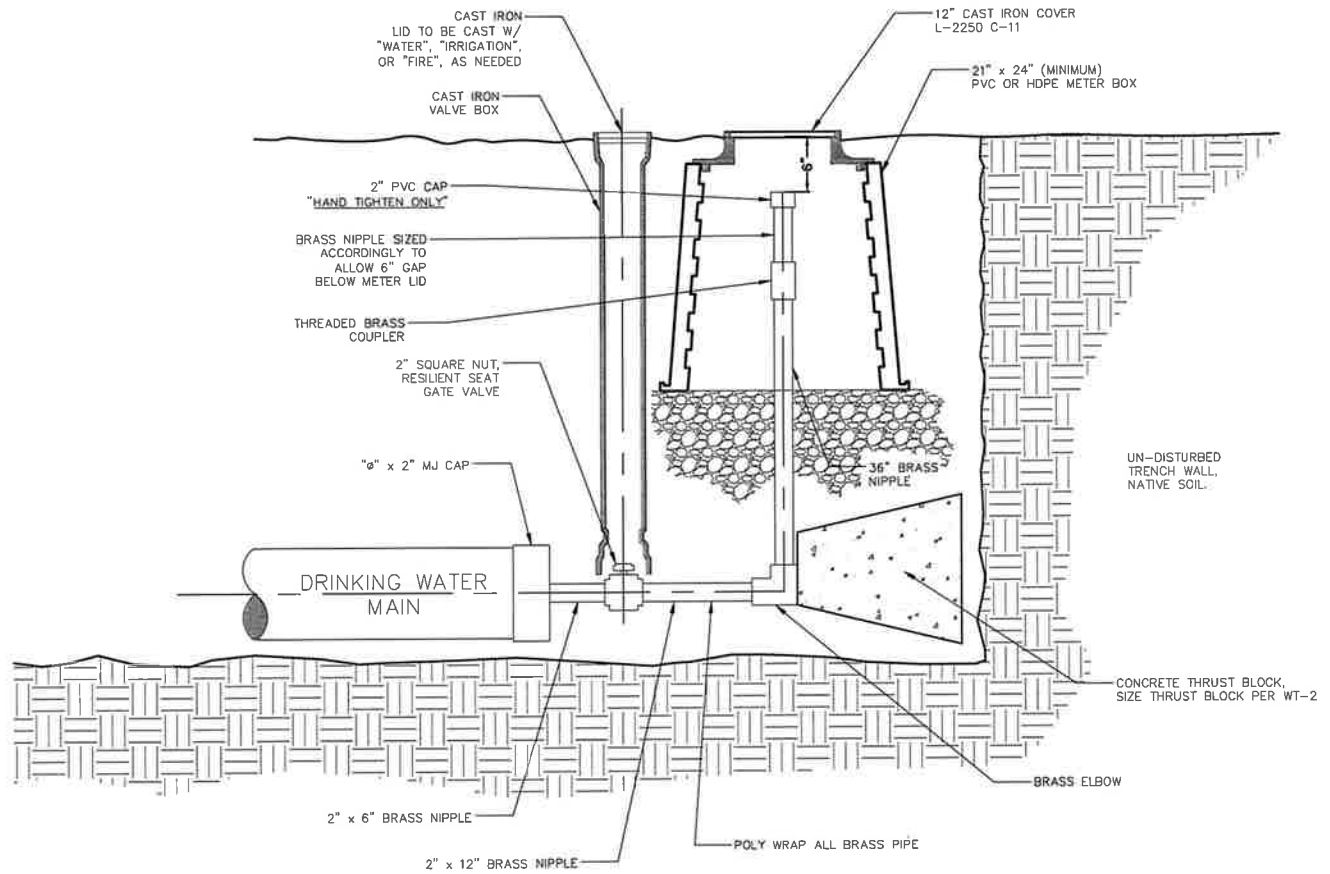

BRIAN HEAD TOWN

2" BLOW OFF VALVE  
DETAIL

STANDARD DWG. NO.

403 1 OF 1

APPROVED:

DATE: BY: LBB

REVISIONS		
DATE	DESCRIPTION	BY

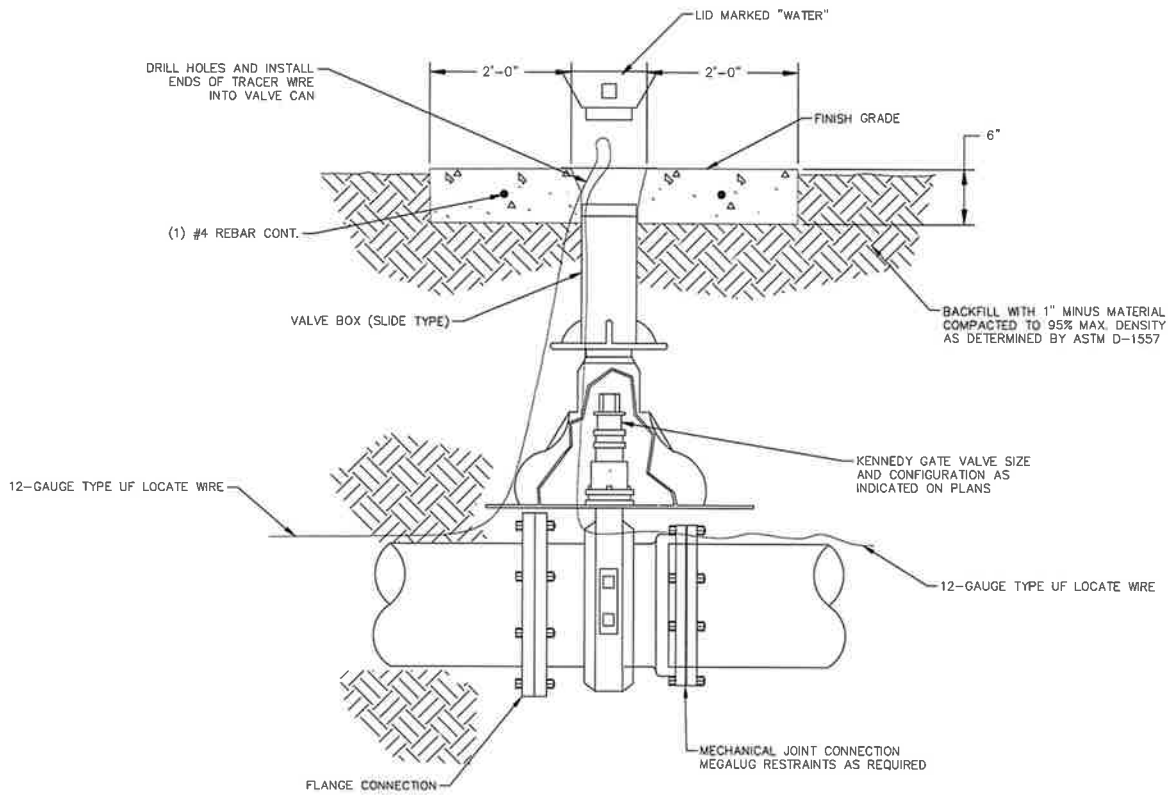

BRIAN HEAD TOWN

STANDARD GATE VALVE  
DETAIL

REVISIONS		
DATE	DESCRIPTION	BY

STANDARD DWG. NO.	
404	1 OF 1
APPROVED:	
DATE:	BY: LBB

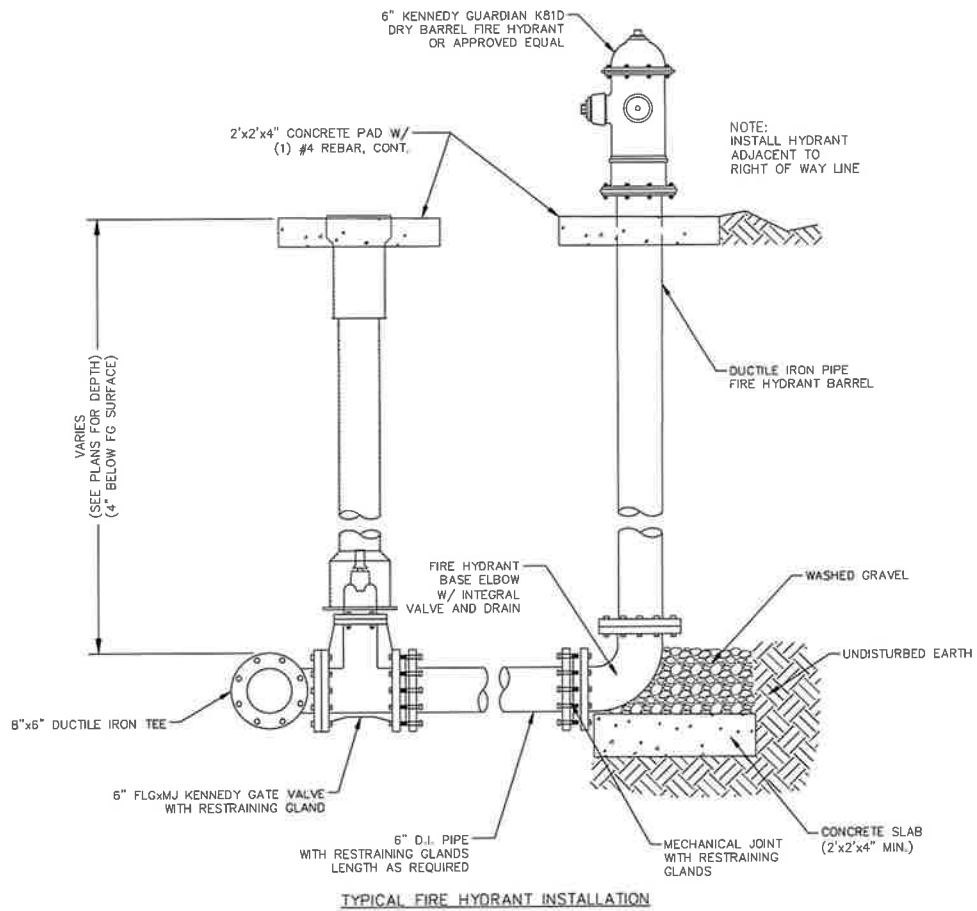

BRIAN HEAD TOWN

STANDARD FIRE HYDRANT ASSEMBLY  
DETAIL

STANDARD DWG. NO.

405 | 1 OF 1

APPROVED:

DATE: | BY: LBB

REVISIONS		
DATE	DESCRIPTION	BY

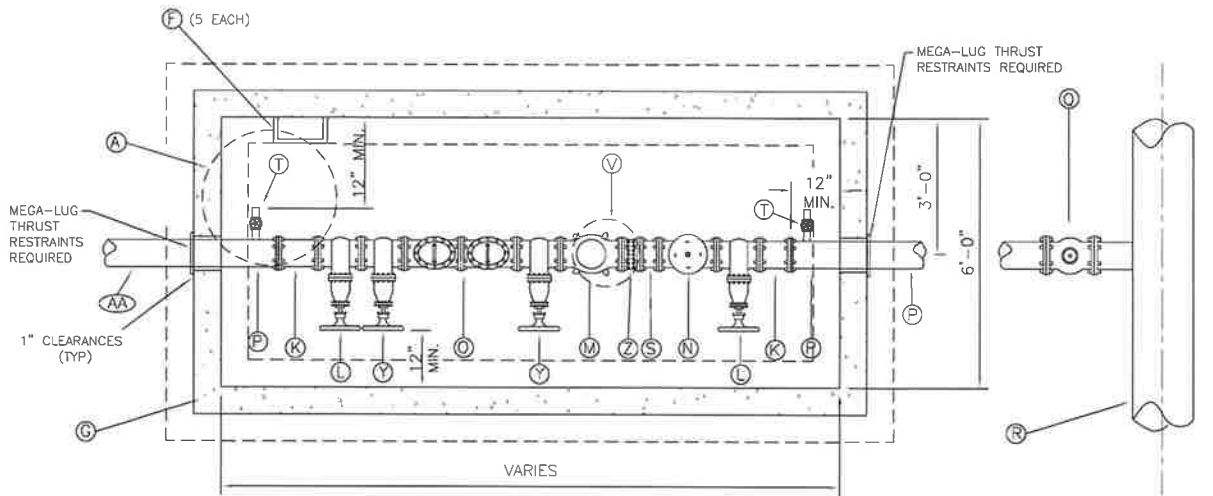

**PLAN**

N.T.S.

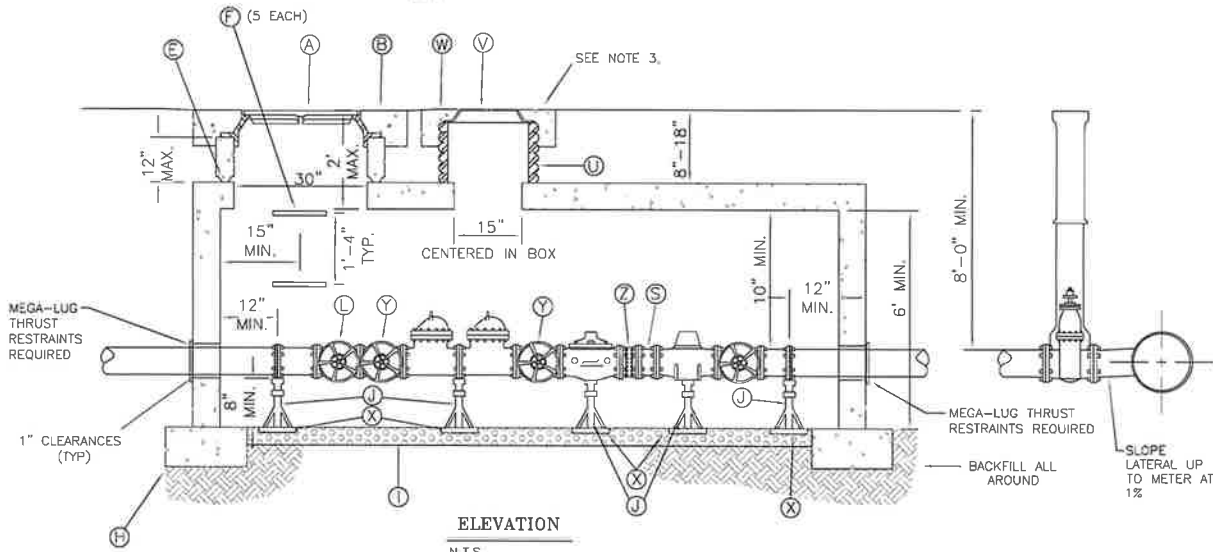

**ELEVATION**

N.T.S.

**NOTES:**

1. UNLESS OTHERWISE SHOWN ALL MATERIALS PER BRIAN HEAD TOWN STANDARDS.
2. CONCRETE VAULT LENGTH & WIDTH SHALL BE SUFFICIENT TO CONTAIN ALL FITTINGS AND MAINTAIN INDICATED CLEARANCE FROM WALLS.
3. WATER METER LIDS & COVERS SHALL ONLY BE INSTALLED IN LANDSCAPED AREAS UNLESS APPROVED BY WATER SUPERINTENDENT.
4. NOT ALLOWED ON PRIVATE SYSTEMS WITH FIRE HYDRANTS.
5. VAULTS ARE DESIGNED TO MEET ASTM C858 WITH AASHTO HS-20 LOADING.
6. PRV IS REQUIRED FOR 80 PSI PRESSURE OR GREATER.
7. STRAINER IS REQUIRED IF A PRV IS REQUIRED.
8. ALL PIPE MATERIALS AND FITTINGS MUST BE RATED FOR WATER SYSTEM PRESSURE.
9. ONLY NFPA 13R FIRE SPRINKLER SYSTEMS ARE ALLOWED WITH THIS DETAIL.
10. FIRE SPRINKLER SYSTEMS SHOULD BE DESIGNED ACCORDING TO REDUCED PRESSURE WHEN USING A PRV IN THE VAULT.

**LEGEND**

SYM	ITEM	DESCRIPTION	SYM	ITEM	DESCRIPTION
(A)	MANHOLE RING AND COVER (RUBBLESS)	D&L A-1180 O.A.E.	(P)	DUCTILE IRON PIPE OR COPPER PIPE	CEMENT LINED OR COPPER
(B)	4' X 8' THICK CONCRETE COLLAR	W/ 40" Ø #4 BARS & FIBERS	(Q)	GATE VALVE WITH BOX	SEE W1
(C)	NOT USED		(R)	FIRE LOOP OR CITY WATER MAIN	
(D)	NOT USED		(S)	FLANGED SPOOL 12" LONG	
(E)	GRADE RING(S)	MUST BE SEALED	(T)	1 1/2" PIPE TAP WITH GATE VALVE AND 4" NIPPLE	
(F)	MANHOLE STEP	(M.A. INDUSTRIES INC. O.A.E.)	(U)	18" DIA. HDPE PIPE	PER PIPE SPEC
(G)	CONCRETE VAULT TOP		(V)	RING & LID W/ 3" PUNCHOUT	D&L-2241 O.A.E.
(H)	8" X 18" FOOTING W/ 3-#4 BARS	ANCOR LV8127T O.A.E.	(W)	30"x30"x8" THICK CONCRETE COLLAR	
(I)	4" THICK DRAIN GRAVEL		(X)	12" x 12" x 2" CONCRETE BLOCK	
(J)	(S) LEVELING JACKS (LENGTH VARIES)	SLIDEWINDER PART #23535 BY BARKER MANUF. CO.	(Y)	BACKFLOW ASSEMBLY VALVE	
(K)	6" MIN. FLANGE ADAPTOR	CEMENT LINED	(Z)	STRAINER (IF REQUIRED)	PURCHASED FROM CITY
(L)	GATE VALVE WITH HANDWHEEL	NON-RISING STEM	(AA)	DUCTILE IRON PIPE OR COPPER PIPE (TO 10' OUTSIDE OF VAULT)	
(M)	FLOW METER (PURCHASED FROM CITY)	MACH 10			
(N)	PRESSURE REDUCING VALVE (IF REQ'D)	AWWA APPROVED			
(O)	DOUBLE CHECK DETECTOR VALVE (DCDA)	AWWA APPROVED			

**BRIAN HEAD TOWN**

**1 1/2"-4" WATER METER  
(COMBINED CULINARY & FIRE SPRINKLER FLOWS)**

STANDARD DWG. NO.

406 1 OF 1

APPROVED:

DATE: BY: LBB

REVISIONS		
DATE	DESCRIPTION	BY

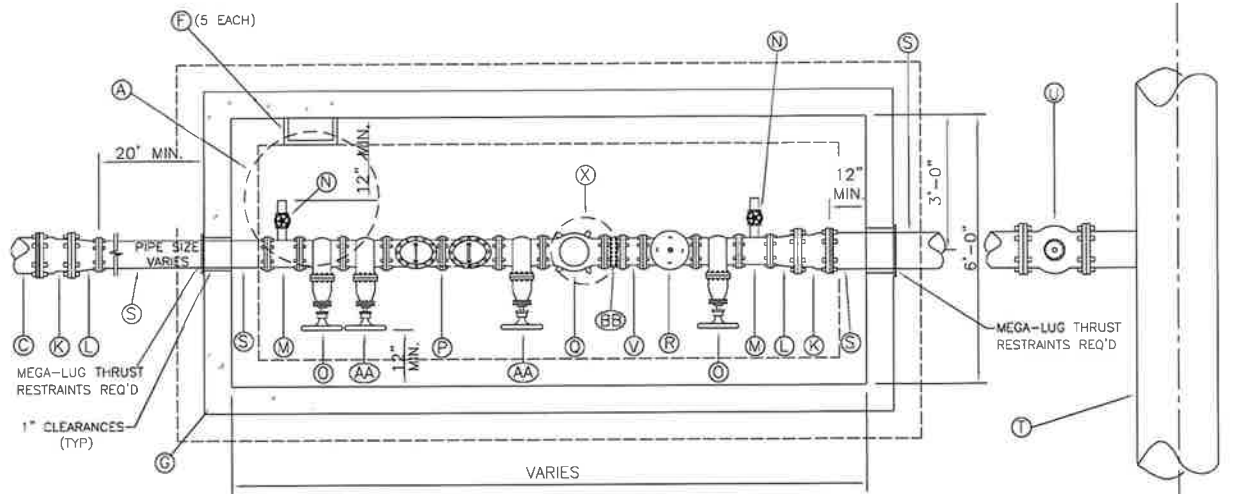

**PLAN**

N.T.S.

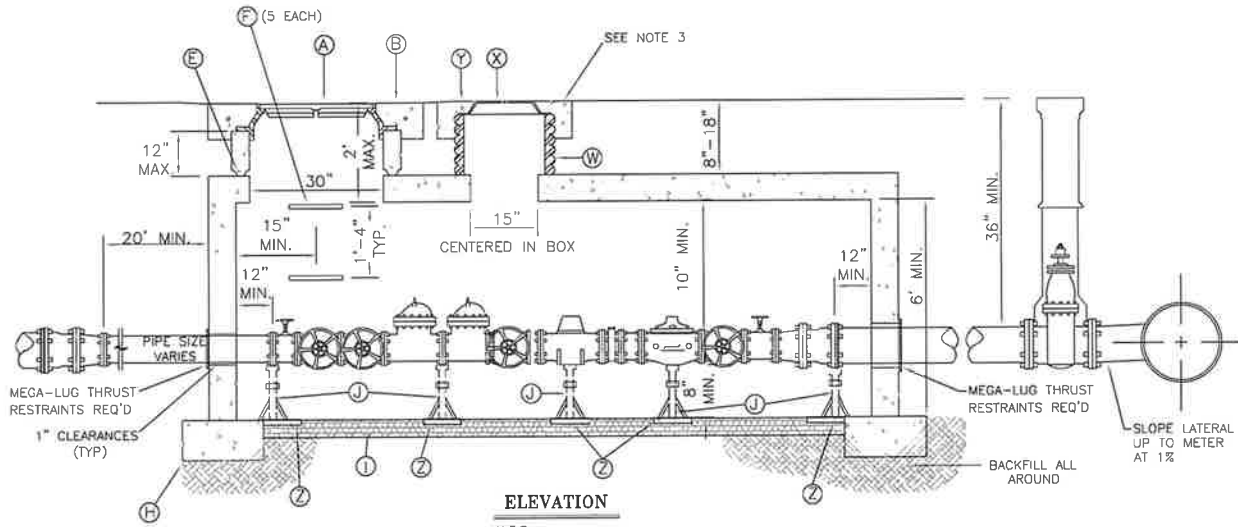

**ELEVATION**

N.T.S.

**NOTES:**

1. UNLESS OTHERWISE SHOWN ALL MATERIALS PER BRIAN HEAD TOWN STANDARDS.
2. CONCRETE VAULT LENGTH & WIDTH SHALL BE SUFFICIENT TO CONTAIN ALL FITTINGS AND MAINTAIN INDICATED CLEARANCE FROM WALLS.
3. WATER METER LIDS & COVERS SHALL ONLY BE INSTALLED IN LANDSCAPED AREAS UNLESS APPROVED BY WATER SUPERINTENDENT.
4. REQUIRED ON PRIVATE WATER SYSTEMS WITH FIRE HYDRANTS.
5. VAULTS ARE DESIGNED TO MEET ASTM C858 WITH AASHTO HS-20 LOADING.
6. PRV IS REQUIRED FOR 80 PSI PRESSURE OR GREATER.
7. STRAINER IS REQUIRED IF PRV IS REQUIRED.
8. ALL PIPE MATERIALS AND FITTINGS MUST BE RATED FOR WATER SYSTEM PRESSURE.
9. ONLY NEPA 13R FIRE SPRINKLER SYSTEMS ARE ALLOWED WITH THIS DETAIL.
10. FIRE SPRINKLER SYSTEMS SHOULD BE DESIGNED ACCORDING TO REDUCED PRESSURE WHEN USING A PRV INSIDE THE VAULT.

**LEGEND**

NO.	ITEM	DESCRIPTION	NO.	ITEM	DESCRIPTION
(A)	MANHOLE RING AND COVER (RIBLESS)	D&L A-1180 O.A.E.	(P)	6" DOUBLE CHECK DETECTOR VALVE (DCDA)	AWWA APPROVED
(B)	4" x 8" THICK CONCRETE COLLAR	W/ 40' Ø #4 BARS & FIBERS	(Q)	FLOW METER	(PURCHASED FROM CITY)
(C)	PIPE MATERIAL PER PLUMBING CODE		(R)	6" PRESSURE REDUCING VALVE (IF REQ'D)	AWWA APPROVED
(D)	NOT USED		(S)	6" MIN. D.I. PIPE	CEMENT LINED
(E)	GRADE RINGS	MUST BE SEALED	(T)	CITY WATER MAIN	
(F)	MANHOLE STEP	(M.A. INDUSTRIES INC. O.A.E.)	(U)	GATE VALVE WITH BOX	SEE W1
(G)	CONCRETE VAULT TOP	AMCOR UV81271 O.A.E.	(V)	6" FLANGED SPOOL 12" LONG	CEMENT LINED
(H)	9" x 18" FOOTING W/ 3-#4 BARS		(W)	18" DIA. HDPE PIPE	PER PIPE SPEC.
(I)	4" THICK DRAIN GRAVEL		(X)	RING & LID w/ 2" PUNCHOUT	D&L-2241 O.A.E.
(J)	(Z) LEVELING JACKS (LENGTH VARIES)	SUDDWINDER PART #23535 BY BARKER MANUF. CO.	(Y)	30"x30"x8" THICK CONCRETE COLLAR	
(K)	6" MIN. FLANGE ADAPTOR	CEMENT LINED	(Z)	12" x 12" x 2" CONCRETE BLOCK	
(L)	x" x 6" FLANGED REDUCER (IF REQ'D)	CEMENT LINED	(AA)	BACKFLOW ASSEMBLY VALVE	
(M)	6" FLANGED STEEL SPOOL WITH 2" OUTLET	EPOXY COATED AND LINED	(BB)	STRAINER (IF REQUIRED)	PURCHASED FROM CITY
(N)	2" GATE VALVE WITH 4" NIPPLE				
(O)	6" GATE VALVE WITH HANDWHEEL	NON-RISING STEM			

**BRIAN HEAD TOWN**

**WATER METER WITH FIRE FLOW  
(COMBINED CULINARY & PRIVATE FIRE HYDRANT FLOWS)**

STANDARD DWG. NO.

407 1 OF 1

APPROVED:

DATE: BY: LBB

REVISIONS		
DATE	DESCRIPTION	BY

TOWN OF BRIAN HEAD TESTING AND INSPECTION STANDARDS

SANITARY SEWER*	PIPELINE INSPECTION-- ALIGNMENT, GRADE AND CLASS OF PIPE LOW PRESSURE AIR TEST OR INFILTRATION TEST DISPLACEMENT TEST
STORM DRAINAGE*	PIPELINE INSPECTION--ALIGNMENT, GRADE AND CLASS OF PIPE CATCH BASIN BOXES INSPECTION-- DEPTH & REBAR
LAND DRAINAGE*	PIPELINE INSPECTION-- ALIGNMENT, GRADE AND CLASS OF PIPE AND BEDDING METHOD
CULINARY DRAINAGE*	PIPELINE INSPECTION-- ALIGNMENT, GRADE AND CLASS OF PIPE, BEDDING METHOD, SERVICES AND INSTALLATION PRESSURE TEST-- MINIMUM 200 PSI FOR 2 HOUR CHLORINATION TEST--MINIMUM 30 RPM FOR 24 HOURS CLEAR WATER TEST
ROADWAY**	SUB BASE INSPECTION-- DEPTH AND COMPACTION BEFORE ROAD BASE PLACEMENT ALL UTILITY LINES NEED TO BE INSTALLED ROAD BASE DENSITY TEST-- DEPTH AND COMPACTION (CONTRACTOR RESPONSIBLE TO GIVE ROAD BASE PROCTOR TO CITY) ASPHALT PLACEMENT-- DEPTH AND COMPACTION
CURB, GUTTER AND SIDEWALK	CURB, GUTTER AND SIDEWALK INSPECTION-- DEPTH AND COMPACTION, SLUMP, ENTRAINED AIR AND COMPRESSIVE STRENGTH

\* CONTRACTOR SHALL NOT FLUSH ROCK & DEBRIS FROM NEWLY INSTALLED PIPELINES DOWN STREAM INTO EXISTING SYSTEM.

\*\*TESTING ON ROAD WAY SHALL BE DONE BY INDEPENDANT, CERTIFIED LAB. FREQUENCY OF TESTING SHALL BE DETERMINED BY THE TOWN.

BRIAN HEAD TOWN

REVISIONS		
DATE	DESCRIPTION	BY

TESTING AND INSPECTION STANDARDS

STANDARD DWG. NO.	
501	1 OF 1
APPROVED:	
DATE:	BY: LBB

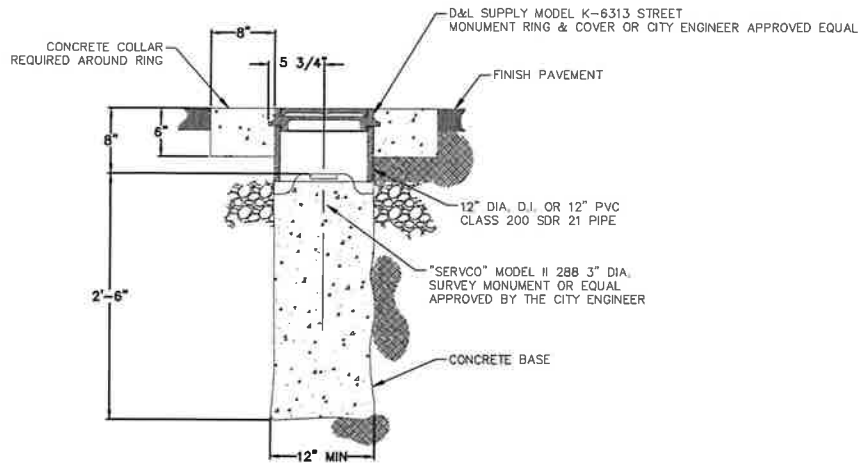

SURVEY MONUMENT SECTION

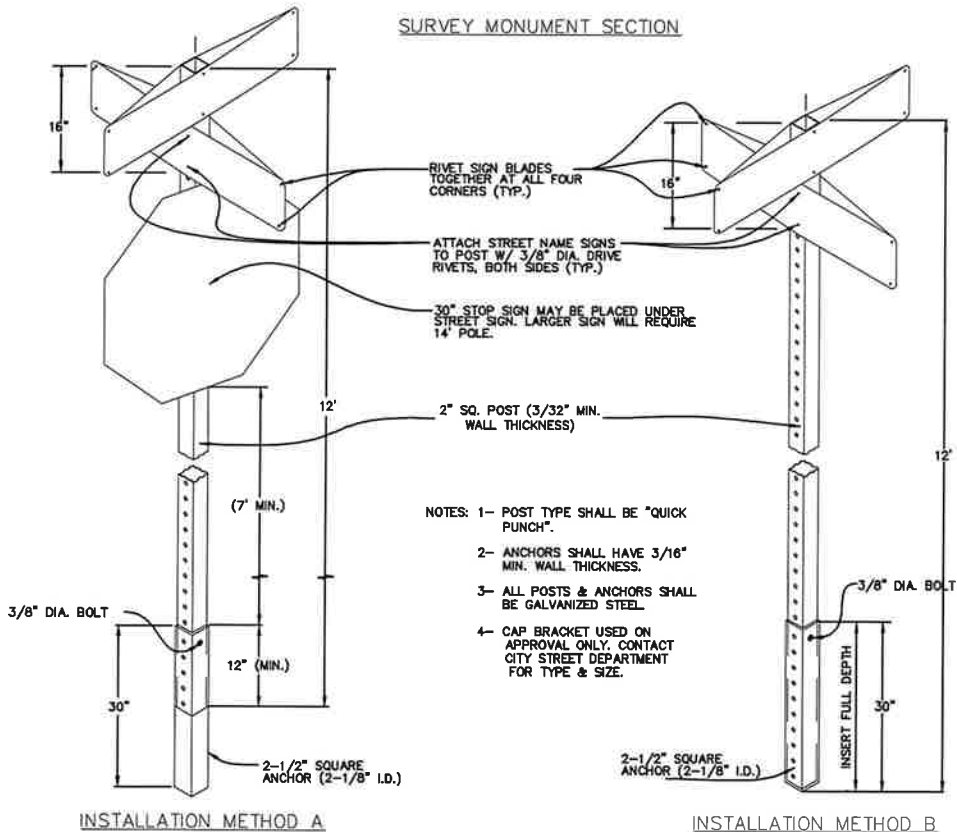

- NOTES:
- 1- POST TYPE SHALL BE "QUICK PUNCH".
  - 2- ANCHORS SHALL HAVE 3/16" MIN. WALL THICKNESS.
  - 3- ALL POSTS & ANCHORS SHALL BE GALVANIZED STEEL.
  - 4- CAP BRACKET USED ON APPROVAL ONLY. CONTACT CITY STREET DEPARTMENT FOR TYPE & SIZE.

INSTALLATION METHOD A

INSTALLATION METHOD B

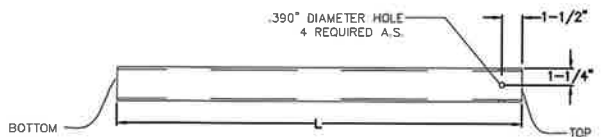

SIGN ANCHOR DETAIL

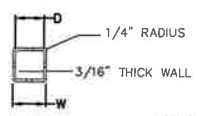

STREET SIGN DETAIL

MARK	DIM.	TOLERANCE
D	2-1/8"	+1/16", -0"
L	30"	± 1/2"
W	2-1/2"	± 1/64"

BRIAN HEAD TOWN

STREET SIGN AND MONUMENT DETAILS

REVISIONS		
DATE	DESCRIPTION	BY

STANDARD DWG. NO.	
502	1 OF 1
APPROVED:	
DATE:	BY: LBB

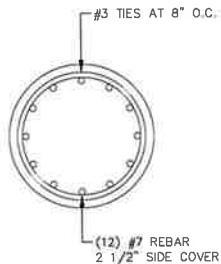
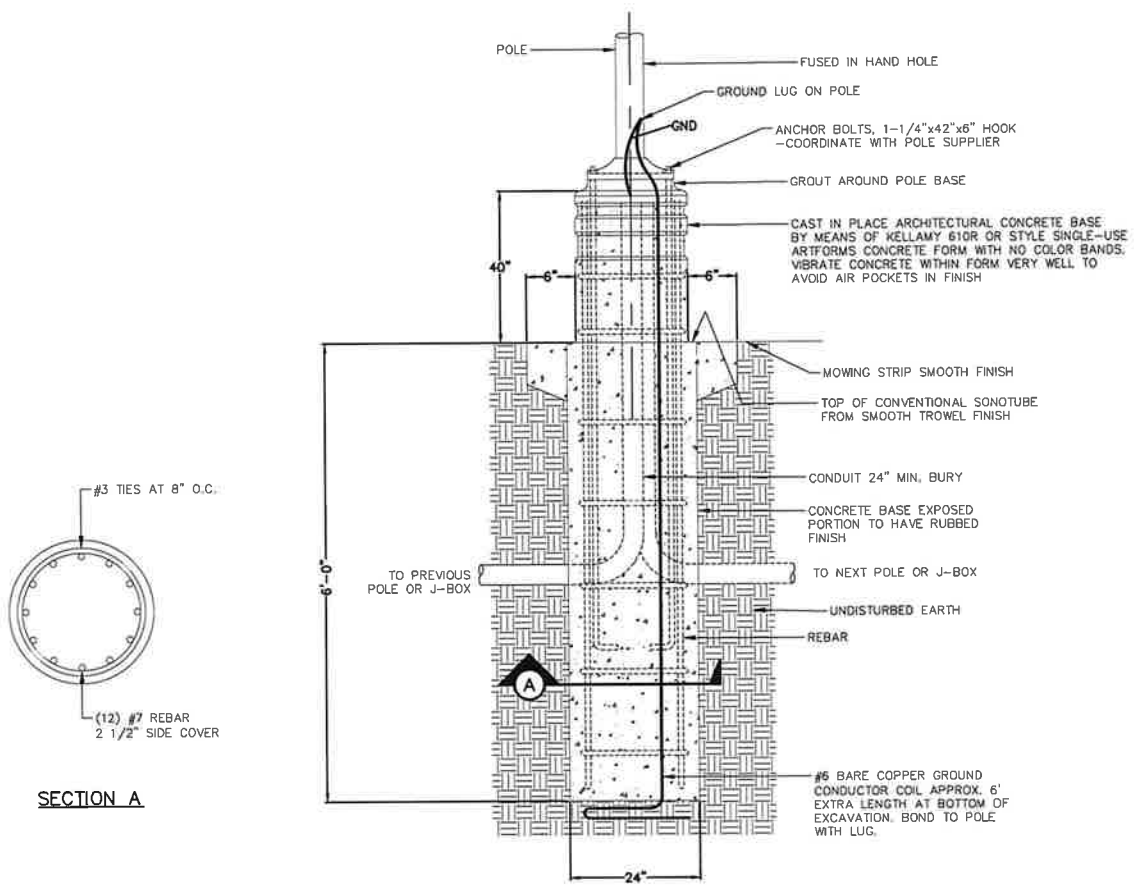

**SECTION A**

**SMALL AREA LIGHTING POLE MOUNTING DETAIL**

**STREET LIGHTING FIXTURE NOTES:**

1. LIGHTS ARE TO BE 240 VOLTS.
2. CONTRACTOR IS TO USE HOLOPHONE (<http://www.holophane.com>) LIGHTING EQUIPMENT.
3. CONTRACTOR IS TO USE THE FOLLOWING ITEMS FOR STREET LAMPS UNLESS AN ALTERNATE IS APPROVED BY THE TOWN.
 

ITEM	HOLOPHANE CATALOG NUMBER
HEAD:	GEI0DMHMC2AS73 H
ARM:	HALLBROOK ARM WITH SCROLL
POLE:	P12S4/18-CA/DB
4. STREET LAMPS ARE TO BE: CONTEMPORARY DECORATIVE OUTDOOR LUMINARIE, PRISMATIC GLASS OPTICAL LENS, CAST ALUMINUM HOUSING, ONE PIECE ALUMINUM CONSTRUCTION, HEAD, ARM AND POLE TO BE DARK GREEN IN COLOR (RAL-6009).
5. USE ONLY 100W METAL HALIDE LAMP(S)
6. CONTRACTOR MUST PROVIDE COLOR SAMPLE WITH SUBMITTAL PACKAGE.

BRIAN HEAD TOWN

STREET LIGHT POLE DETAILS

REVISIONS		
DATE	DESCRIPTION	BY

STANDARD DWG. NO.	
503	1 OF 1
APPROVED:	
DATE:	BY: LBB

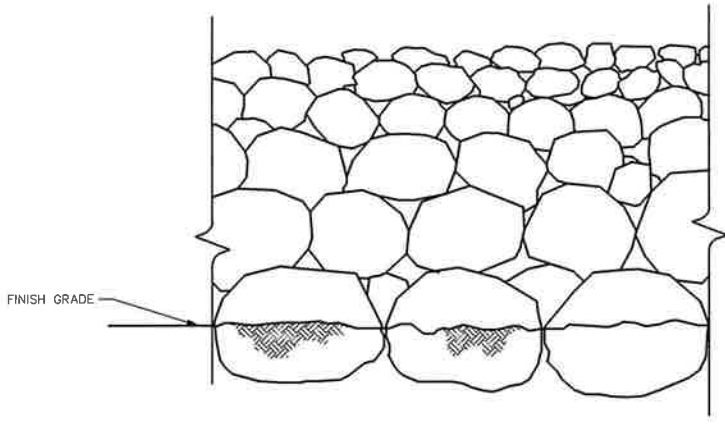

FRONT VIEW

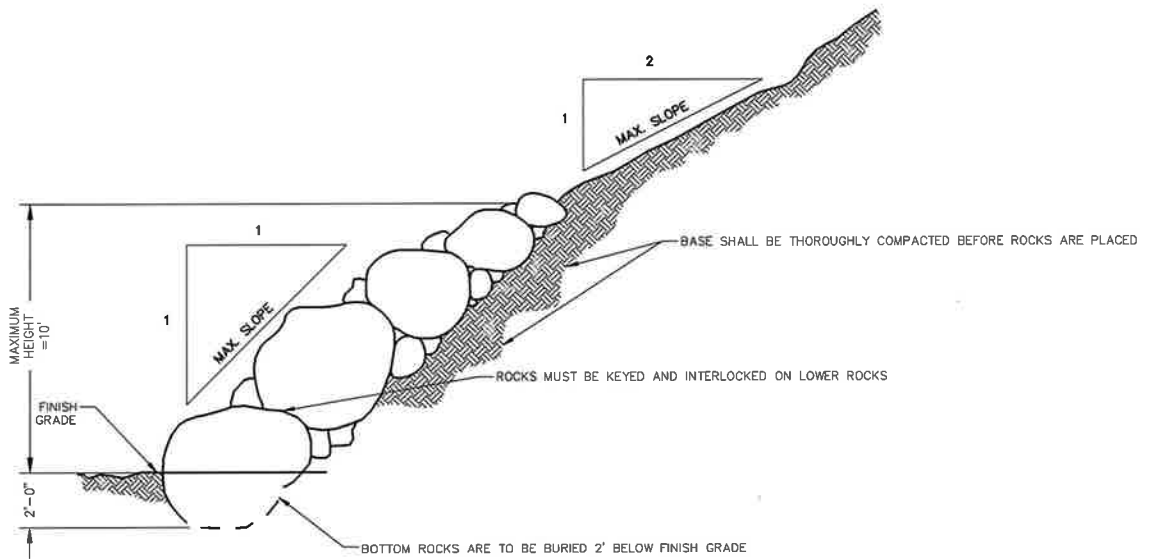

CROSS SECTION

NOTE: THE ROCK SHALL BE HARD, DURABLE, ANGULAR FIELD STONES AND SHALL INTERLOCK WITH ADJACENT ROCKS. THE ROCKS SHALL BE SET SO AS NOT TO EXCEED A 1 TO 1 SLOPE AS SHOWN. LARGE IRREGULARITIES BETWEEN STONES AND SHALL BE FILLED WITH ROCK SPALLS OF SUITABLE SIZE RAMMED TIGHTLY INTO PLACE FROM THE BOTTOM OF THE TOP.

BRIAN HEAD TOWN

ROCK RETAINING WALL DETAILS

STANDARD DWG. NO.

504 1 OF 1

APPROVED:

DATE: BY: LBB

REVISIONS		
DATE	DESCRIPTION	BY

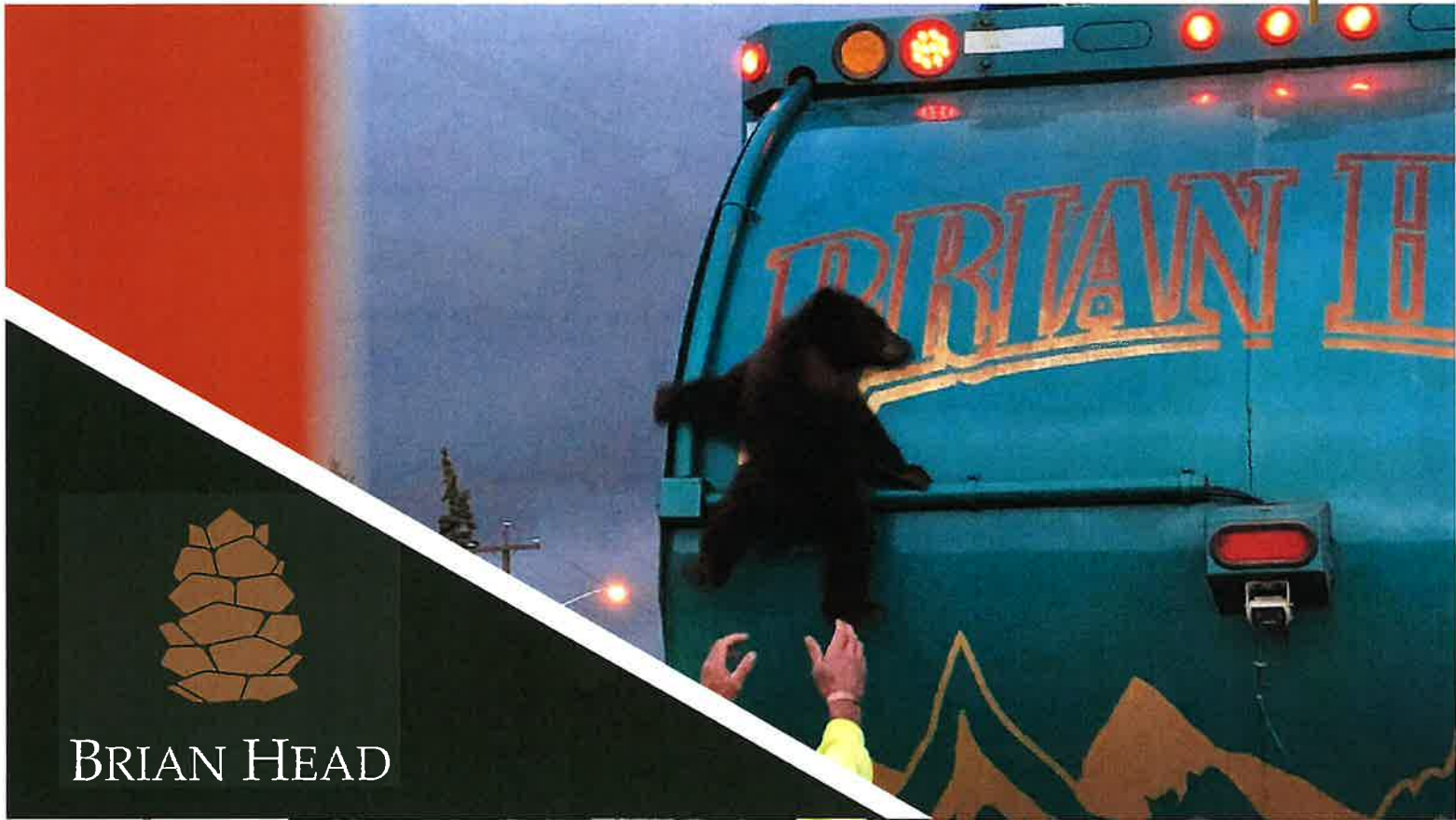
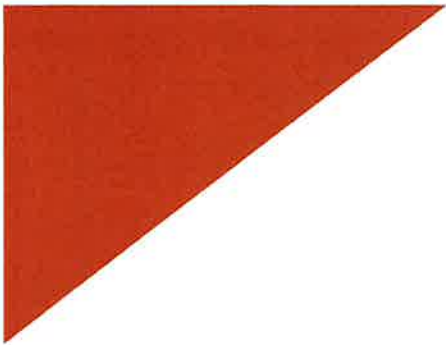

BRIAN HEAD

