



**PARK CITY COUNCIL MEETING
SUMMIT COUNTY, UTAH
May 7, 2026**

The Council of Park City, Utah, will hold its regular meeting in person at the Marsac Municipal Building, City Council Chambers, at 445 Marsac Avenue, Park City, Utah 84060. Meetings will also be available online and may have options to listen, watch, or participate virtually. [Click here for more information.](#)

Zoom Link: <https://us02web.zoom.us/j/85927879080>

CLOSED SESSION - 2:30 p.m.

The Council may consider a motion to enter into a closed session for specific purposes allowed under the Open and Public Meetings Act (Utah Code § 52-4-205), including to discuss the purchase, exchange, lease, or sale of real property; litigation; the character, competence, or fitness of an individual; for attorney-client communications (Utah Code section 78B-1-137); or any other lawful purpose.

WORK SESSION

3:15 p.m. - Review Transportation Performance Metrics

4:15 p.m. - Fire Conditions Update with PC Fire Marshal and Park City Fire District

4:30 p.m. - FY27 Tentative Budget Discussion

5:00 p.m. - IT Assessment Findings Presentation by Berry Dunn

5:15 p.m. - Break

REGULAR MEETING - 5:30 p.m.

I. ROLL CALL

II. PRESENTATIONS

1. Presentation of the 2026 Cindy Matsumoto Historic Preservation Award and Consideration to Approve Resolution No. 07-2026, a Resolution Proclaiming May 2026 as Historic Preservation Month in Park City
(A) Action

COMMUNICATIONS AND DISCLOSURES FROM COUNCIL AND STAFF

Council Questions and Comments

III. PUBLIC INPUT (ANY MATTER OF CITY BUSINESS NOT SCHEDULED ON THE AGENDA)

IV. CONSENT AGENDA

1. Request to Approve Ordinance 2026-08, and Ordinance Amending Title 2, Chapter 3, Section 11 of Park City Municipal Code, Review of Disposals of Significant Parcels of Real Property
2. Request to Approve Ordinance No. 2026-09, an Ordinance Accepting the Public

Improvements for the Moonshadow Condominiums Development Project

3. Request to Approve Ordinance No. 2026-10, an Ordinance Accepting the Public Improvements for the Huntsman Estates Development Project
4. Request to Approve Ordinance 2026-11, an Ordinance Adopting the American Public Works Association (APWA) Manual of Standard Specifications, the APWA Manual of Standard Plans, and the Park City 2026 Supplemental Standard Plans and Specifications to be Used for the Design and Construction of Projects
5. Request to Adopt Resolution 08-2026, a Resolution Proclaiming June 2026 as Pride Month in Park City
6. Set a Public Hearing under Utah Code 10-3-818 to Consider Compensation Increases for Executive Municipal Officers on May 21, 2026, Regular City Council Meeting

V. OLD BUSINESS

1. Consideration to Authorize the City Manager to Execute Agreements for Bus Stop Improvement Phases 2 & 3 Construction Not to Exceed \$10,000,000 and a Little Kate Corridor Design Services Amendment of \$140,000, in Forms Approved by the City Attorney's Office, Not to Exceed \$3,100,000, and to De-accession "Art Kids" from the City's Public Art Collection
(A) Public Input (B) Action
2. Consideration to Authorize the City Manager to Execute a Professional Services Agreement with Horrocks Engineers, LLC., in a Form Approved by the City Attorney, Not to Exceed \$2,100,000, for Environmental Clearance, Preliminary Engineering, and Final Design Support to Advance the Re-Create 248 Transit Priority Project
(A) Public Input (B) Action

VI. NEW BUSINESS

1. Consideration to Approve Ordinance No. 2026-12, an Ordinance Adopting a Tentative Budget for Fiscal Year 2027 for Park City Municipal Corporation and Its Related Agencies and Authorizing the Computation of the Property Tax Rate at a No Tax Increase Rate, and Set a Public Hearing to Consider Adoption of the Final Budget on June 11, 2026, at a Regular City Council Meeting
(A) Public Hearing (B) Action
2. Consideration to Authorize the Mayor to Execute a Quit Claim Deed, in a Form Approved by the City Attorney's Office, to Transfer Ownership of Land within the Marsac Roundabout to UDOT
(A) Public Input (B) Action

VII. ADJOURNMENT

PARK CITY REDEVELOPMENT AGENCY MEETING

ROLL CALL

PUBLIC INPUT (ANY MATTER OF CITY BUSINESS NOT SCHEDULED ON THE AGENDA)

NEW BUSINESS

1. Consideration to Authorize the Chair of the Park City Redevelopment Agency to Grant Easements, in a Form Approved by the City Attorney's Office, for Transit Improvements and Operations
(A) Public Input (B) Action
2. Consideration to Authorize the Chair of the Park City Redevelopment Agency to Execute a Quit Claim Deed, in a Form Approved by the City Attorney's Office, to Transfer Ownership of Land within the Marsac Roundabout to UDOT
(A) Public Input (B) Action

ADJOURNMENT

Pursuant to the Americans with Disabilities Act, individuals needing special accommodations during the meeting should notify the City Recorder at 435-615-5007 at least 24 hours prior to the meeting.

***Parking is available at no charge for Council meeting attendees who park in the China Bridge parking structure.**



City Council Staff Report

Subject: Transportation Performance Metrics
Authors: Tim Sanderson, Transportation Director
William DeGroot, Transit Manager
Robbie Smoot, Sr. Data & Financial Analyst
Department: Transportation
Date: May 7, 2026

Executive Summary

This report presents a recommended framework of transportation performance metrics and service standards to evaluate how well Park City Municipal Corporation's (PCMC) transportation system supports safety, mobility, accessibility, sustainability, and reliability.

The framework establishes a consistent, data-driven approach to monitoring system performance and informing policy, funding, and capital investment decisions. It aligns transportation decision-making with the City's adopted transportation goals, including those related to safety, multimodal mobility, and climate.

The proposed framework is organized around key transportation outcomes and reflects PCMC's adopted multimodal transportation hierarchy, which prioritizes walking, bicycling, and transit over general-purpose vehicle travel and parking. Within this structure, mode share is the primary system-level outcome, with other metrics serving as supporting indicators.

The framework also distinguishes between ridership-focused and coverage-focused transit services to ensure that performance expectations reflect intended service objectives.

Adoption of this framework will improve transparency, support a proactive performance-based management approach, and provide a foundation for ongoing public reporting and continuous system improvement.

Recommended Action

Staff recommends that the City Council:

- Adopt the proposed transportation metrics and service standards.
- Direct staff to update and publish performance metrics on a regular basis and report trends to City Council.

Analysis

Policy Context

Park City's transportation network encompasses transit, parking, active transportation, and roadway infrastructure, all operating within the unique context of a seasonal mountain community with significant demand fluctuations between peak and off-peak periods. Park City has adopted multiple plans and policies that emphasize safety, multimodal access, environmental sustainability, and the efficient use of transportation infrastructure. These include the Park City Forward: Long Range Transportation Plan, General Plan, Bike and Pedestrian Plan and climate-related goals.

Since July 1, 2021, Park City Transit has operated as a municipally focused network providing service within Park City's boundaries. Transit is one component of the broader transportation system addressed in this report.

Establishing performance standards and metrics across several modes provides a clear mechanism for evaluating progress toward these adopted objectives and for guiding future policy, operational, and capital investment decisions.

Framework Overview

The proposed framework is grounded in PCMC's multimodal transportation hierarchy, which prioritizes active transportation modes and transit over personal vehicles.



Within this structure, mode share serves as the highest-priority system outcome, reflecting how people choose to travel and providing a direct measure of progress toward safety, mobility, sustainability, and climate goals.

Other metrics, such as transit and parking productivity, service reliability, and customer experience, function as leading indicators that influence mode choice over time.

Higher priority modes are evaluated based on safety, access, reliability, efficiency, and customer experience. Lower-priority modes, such as vehicle traffic and parking, are evaluated as management indicators to support overall system performance.

This framework is intended to guide service planning, operational adjustments, and capital investment recommendations in a manner that is consistent with adopted City policy.

Recommended Transportation Metrics and Service Standards

Metric	Baseline	Staff Recommendation / Service Standard
Mode Share by Travel Mode (Highest Priority Outcome)	TBD (periodic survey-based data)	The purpose of the Mode Share metric is to reduce automobile dependency by measuring the proportion of trips made by each travel mode. This metric provides insight into overall travel behavior and progress toward the City’s safety, mobility, and sustainability goals. The goal is to reduce automobile mode share by one percentage point over reporting periods, while increasing the share of trips made by walking, bicycling, and transit.
Service Standards		
Transit Customers per Revenue Hour (peak and off-peak periods, and by route type)	<u>Ridership Service:</u> Peak: 26 Off Peak: 14 <u>Coverage Service:</u> Peak: 15 Off Peak: 8	The purpose of the Customers per Revenue Hour metric is to monitor the efficient use of transit resources by measuring passenger activity relative to the service provided. This metric provides insight into service productivity and helps inform service planning decisions.
Residential Coverage	90% coverage within a half mile of a fixed route line	The purpose of the Residential Coverage metric is to ensure equitable access to transit by measuring the proportion of residents within walking distance of service. This metric provides insight into geographic accessibility and supports network design decisions. The goal is to maintain a high percentage of residents within a half mile of transit service, recognizing local constraints.
Surge Parking Performance (4PM – 9PM)	TBD	The purpose of the Surge Parking Performance metric is to evaluate how the parking system performs during peak days by measuring occupancy, duration of full conditions, and spillover effects. This metric provides insight into system resilience under stress conditions. The goal is to manage peak demand to minimize system disruption and support overall transportation performance.
Performance Metrics		

Transit On-Time Performance (OTP)	81% Standard during Winter Service Day; 92% Standard for all other times of service	The purpose of the On-Time Performance metric is to ensure reliable transit service by measuring adherence to scheduled departure times. This metric provides insight into service reliability and customer experience. The goal is to achieve at least 90 percent of departures within the defined on-time window of 0 seconds early to 5 minutes late.
Pull-Out Adherence	97%	The purpose of the Pull-Out Adherence metric is to ensure consistent delivery of scheduled service by measuring the percentage of trips successfully dispatched. This metric provides insight into operational reliability. The goal is to minimize missed pull-outs and address recurring service delivery issues.
Customer Feedback and Service Requests	85%	The purpose of the Customer Feedback metric is to improve service quality by responding to Customer concerns within 48 hours of receipt. The goal is to improve response times to support continuous service improvement.

1. Intended System Outcome

Metric: Mode Share by Travel Mode

Mode share measures how people travel within Park City across all modes, including private automobile, transit, walking, and bicycling. It serves as the primary system-level outcome for PCMC’s transportation framework.

Mode share can provide a comprehensive measure of progress toward the City’s safety, mobility, sustainability, and climate goals by reflecting changes in travel behavior over time.

Methodology

Mode share is calculated using a combination of travel survey data, regional or state travel models, census-based journey-to-work data, and, where available, locally collected transportation data. During the development of Park City Forward, the current mode split was:

Existing Mode Split				
Drive Alone: 52%	Car Pool: 28%	Transit: 5%	Bike: 5%	Walk: 9%

Based on the Park City Forward projects each being assigned a reasonable mode shift percentage, mode share goals for 2050 were established:

2050 Mode Split Target				
Drive Alone: 36%	Car Pool: 33%	Transit: 10%	Bike: 9%	Walk: 12%

- *Recommendation:* To hit the established mode split targets, it is recommended that an 1% annual reduction of single occupant automobile mode share be established.

Reporting Considerations

Because this data relies on statistically valid surveys and regional datasets, it is not updated continuously. The American Community Survey (ACS) is an ongoing survey conducted by the U.S. Census Bureau every month, with data collected continuously throughout the year. It samples approximately 3.5 million households annually, providing 5-year estimates 1-year supplemental estimates. As the ACS asks limited questions about non-work related trips supplementary surveys are needed to develop reliable mode split targets. Staff anticipates reporting mode share on a periodic basis (e.g., every two to three years).

Mode share should be interpreted as a long-term outcome measure and evaluated alongside supporting indicators such as transit ridership, reliability, and active transportation activity.

2. Service Standards

Service standards define expected levels of performance for transit and parking systems based on their intended function within the transportation network.

Service standards may be applied seasonally to reflect variations in demand throughout the year. Peak and non-peak periods may have different performance expectations to account for changes in travel patterns, visitor activity, and system demand.

where service can be adjusted to improve efficiency while maintaining access.

Metric: Residential Coverage within 0.5 Miles of Transit

Measures the percentage of PCMC residences within a half-mile walk of fixed-route transit service.

Methodology

Calculated using GIS-based analysis of residences relative to transit routes.

- *Recommendation:* 9,000 residences within 0.5 miles ÷ 10,000 total residences = 90% coverage

Reporting Considerations

Evaluated periodically and in coordination with service changes, land use patterns, and development activity.

Metric: Surge Parking Performance

Evaluates how the parking system performs during peak demand conditions.

Methodology

Measured using:

- Peak occupancy during identified peak days
- Duration of conditions at or above defined capacity thresholds
- Observed spillover effects where measurable

Parking performance is evaluated between 2:00 PM and 8:00 PM on peak days.

Peak days are established in advance by the Traffic Manager, based on known high-demand conditions.

- *Example:* Peak occupancy reaches 95% at 6:00 PM, with 1.5 hours above 95% capacity and 50 vehicles observed in overflow locations.

Reporting Considerations

This metric focuses on peak conditions rather than average utilization and is used to assess system resilience and inform parking management strategies.

3. Performance Metrics

Metric: Transit On-Time Performance (Departures)

Measures schedule adherence based on transit vehicle departures.

Methodology

Calculated as the percentage of departures occurring between 0 seconds early and 5 minutes late.

- *Recommendation:* 80% On-Time during winter service day
- *Recommendation:* 90% On-Time during all other times of service

Reporting Considerations

Reported regularly to monitor system reliability and identify routes or time periods requiring operational adjustments.

Metric: Pull-Out Adherence

Measures the percentage of vehicles leaving the garage on time relative to the schedule.

Methodology

Calculated as the number of vehicles departing on time divided by the total number of scheduled departures.

- *Example:* 190 on-time departures ÷ 200 scheduled departures = 95%
- *Recommendation:* 97%

Considerations

Used to monitor operational reliability and identify recurring issues affecting service delivery.

Metric: Customer Feedback and Service Requests

Tracks transportation-related customer service requests and complaints.

Methodology

Measured using the total number of requests and response times.

- *Example:* 120 requests received, 85% responded to within 48 hours
- Recommendation: 95%

Reporting Considerations

Trends and response times are monitored regularly to identify recurring issues and inform service improvements.

Conclusion

The proposed transportation performance metrics and service standards establish a clear, structured framework for evaluating how well Park City's transportation system is functioning and progressing toward adopted City goals.

By organizing metrics around system outcomes, service standards, and performance measures, the framework provides a consistent and transparent approach to monitoring performance and guiding decision-making. Mode share serves as the primary long-term outcome, while supporting metrics provide actionable insight into system design, operations, and customer experience.

This framework is intended to support a shift from reactive responses to a proactive, performance-based management approach. By regularly monitoring these metrics and comparing results across services, routes, and facility types, staff will be better equipped to allocate resources, adjust service levels, and respond to changing conditions in alignment with City policy.

Adoption of this framework will improve accountability, support ongoing public reporting, and provide a foundation for continuous improvement of the transportation system. Over time, this framework will enable Park City to more effectively manage its transportation system, improve system performance, and support continued progress toward a safer, more sustainable, and more accessible community.



City Council Staff Communications Report

Subject: 2026 Wildfire Conditions Update
Author: Dave Thacker
Department: Building
Date: May 7, 2026

Summary

Wildfire continues to be the most likely and potentially the most significant natural hazard facing Park City. As the community enters the 2026 wildfire season, staff continue to emphasize preparedness, mitigation, and public awareness as critical components in reducing risk to life, property, and the local economy.

Current Conditions

Recent national and regional wildfire activity continues to highlight the scale and frequency of wildfire events. Large wildfires across the country have reinforced concerns regarding public safety, environmental impacts, and long-term economic effects, particularly for tourism-based communities such as Park City.

Wildfire risk remains elevated due to ongoing drought conditions, fuel loading, and the increasing frequency of human-caused ignitions. National data continues to show that human activity is responsible for the majority of wildfire starts, emphasizing the importance of public education and prevention efforts.

Locally, recent wildfire activity, including the Yellow Lake Fire near Francis, demonstrated the potential for extended fire seasons and atypical fire behavior. That event, which burned over 33,000 acres and extended well into late fall, underscores the evolving nature of wildfire risk in the region.

Community Risk and Impacts

Wildfire poses both immediate and long-term risks to Park City. In addition to threats to public safety and property, a large-scale wildfire could significantly impact the local and regional economy. As a destination community, reductions in tourism following a major wildfire event could have lasting economic consequences extending beyond City limits and into the broader State economy.

Ongoing Mitigation and Preparedness Efforts

The City continues to actively manage wildfire risk through a coordinated, multi-departmental approach. Ongoing efforts include:

- Continued implementation and updates to the Community Wildfire Preparedness Plan, including initiation of the next five-year update cycle
- Completion and maintenance of a Community Wildfire Risk Assessment
- Implementation of the Utah Wildland-Urban Interface (WUI) Code and associated Land Management Code amendments to improve structural and landscape resilience
- Annual defensible space and fuels reduction projects on City-owned properties
- Coordination with community partners on regional wildfire mitigation efforts

- Offering individual homeowner wildfire risk assessments
- Participation in the Western Summit County Fuels Committee to coordinate cross-jurisdictional fuels management strategies
- Participation in the Forestry, Fire, and State Lands Interlocal Agreement
- Ongoing public outreach and education related to wildfire risk and prevention
- Maintenance of Firewise USA community certification

Outlook

As the City moves into the 2026 wildfire season, staff will continue to prioritize mitigation, education, and interagency coordination. Public awareness efforts, including seasonal outreach and engagement, remain critical in reducing human-caused ignitions and improving community preparedness.

City Council Staff Report

Subject: FY27 Tentative Budget
Department: Budget Department
Date: May 7, 2026



Recommendation

Review and discuss the FY27 operating and capital budgets in advance of adopting the FY27 Tentative Budget ordinance, computed at a no-tax increase rate for property taxes.

Executive Summary

The City is required to adopt a tentative budget on or before the first City Council meeting in May. Final Budget adoption is scheduled for June 11, 2026. Prior to adoption, Council and staff will continue evaluating projections and requests to further refine the final FY27 budget.

Schedule:

- May 7 – Budget review, public hearing and Tentative Budget adoption
- May 21 – Hold a public hearing for Executive Municipal Officers compensation; Hold a public hearing and consider adopting Elective and Statutory Officers compensation by ordinance.
- June 4 – Follow-up presentations as needed
- June 11 – Public hearing and Final Budget and Fee Schedule adoption

This report summarizes changes incorporated into the FY27 Tentative Budget after previewing the operating and capital requests with Council on [April 9, 2026](#) and [April 30, 2026](#), respectively.

Analysis

The FY27 tentative budget is a culmination of a thorough, multi-month process that begins in January with the development of data-driven revenue projections, followed by in-depth departmental discussions to identify operating and capital needs, and a comprehensive analysis of benefits and compensation by Human Resources.

Through the strategic reallocation of Resort Tax funding, operational efficiencies, and the redeployment of resources previously expended on the Sundance Film Festival, this budget prioritizes high-impact community investments. Key highlights include expanded support for childcare initiatives, non-profit grants, and enhanced Library and Recreation programming.

Operating Budget Updates

Because personnel costs significantly impact every fund, the FY27 Pay Plan remains under active refinement. We continue to develop and analyze multiple scenarios to ensure that the final plan is fiscally sustainable and aligned with our most current

revenue projections. We plan to finalize the pay plan after we have solidified our FY27 sales tax projections.

We are also evaluating Council compensation as part of the FY27 budget process. For several years, compensation for the Mayor and City Council has remained largely static, despite a significant increase in the complexity of governance and the time demands required to represent Park City at local, regional and state levels. The tentative budget proposes an adjustment for the Mayor and Council that aligns with recent market corrections in peer organizations, such as Summit County. This adjustment helps remove financial barriers to entry, facilitating public service for a diverse range of residents while more accurately reflecting the expanded responsibilities and technical demands of these leadership positions.

As part of the budget process we are required to hold a public hearing under [Utah Code Section 10-3-818](#) for Executive Municipal Officers and a separate public hearing for Elective and Statutory officers, which requires adoption through ordinance. Those hearings are scheduled for May 21, 2026.

Based on projections from our health benefits broker, GBS, we are anticipating an 18% increase in health benefit premiums for the upcoming plan year. Since our contract renewal occurs in January 2027, the FY27 Tentative Budget accounts for a prorated 9% increase, representing a \$522,000 impact on the General Fund.

Capital Budget Updates

On April 30, 2026 we reviewed the capital improvement budget with Council. The FY27 Tentative Budget reflects the plan that was presented during that session.

Funding

We are maintaining our preliminary sales tax projections for the tentative budget and will re-evaluate our revenue projections in mid-May when we have received the March sales tax data. This approach allows us to refine our FY27 budget and funding strategies based on actual performance before final budget adoption. As discussed in previous meetings, our funding strategies include:

- Identify operational efficiencies and redeploy Sundance Film Festival expenses
- Reallocate the Resort Communities Sales Tax transfer
- Utilize fund balance to address temporary revenue short falls in FY26 and FY27

Operational Efficiencies & Budget Realignment - \$1,348,688

Departmental Reorganizations

The City has realized operational savings through strategic personnel reorganizations within the Planning and Economic Development departments. By streamlining

structures and realigning staff functions, we have reduced the personnel budgets in these departments.

Sundance Film Festival Transition

With the conclusion of the Sundance Film Festival’s annual event in Park City, all associated expenses have been reallocated in the operating budget. This includes the reversal of the one-time allocations added in FY26 to support the enhanced public safety and transportation plans.

Modernizing Contingency Funding

The City has historically maintained four contingency line items within the operating budget. These funds are rarely utilized and, when needed, are typically for one-time, non-recurring events:

Contingency Fund	FY26 Amount	FY27 Proposal
General Contingency	\$ 100,000	\$ -
Council Contingency	\$ 100,000	\$ -
Snow Removal Contingency	\$ 50,000	\$ -
Abatement Contingency	\$ 48,688	\$ -
Total Operating Reduction	\$ 298,688	\$ -

Strategic Shift: We propose eliminating these recurring "placeholder" allocations from the operating budget. In the event of an emergency, unforeseen need or heavy snow year, the City will evaluate funding on a case-by-case basis through budget adjustments or the use of fund balance, if necessary. This helps tie operating dollars to active programs rather than idle reserves.

Reallocate Resort Communities Sales Tax - \$4.9m from the Transportation Fund

Historically, the City has utilized a formulaic allocation of Resort Communities Tax revenue: between 53-57% to the General Fund, 18-22% to the Capital Improvement Fund and 25% to the Transportation Fund. This practice was essential in the early stages to build up the transportation program and fund health.

However, after years of consistent fiscal stewardship, the Transportation Fund, an Enterprise Fund, has reached a state of maturity. Characterized by a robust fund balance and a proven track record of securing federal/state grants and operating assistance, the fund is self-sufficient and no longer requires the same level of direct Resort Communities Tax subsidy to maintain its high service standards.

By rightsizing the allocation to the Transportation Fund, we can redeploy those resources into the General Fund to support immediate community priorities without requiring a tax increase or immediately impacting our transit operations.

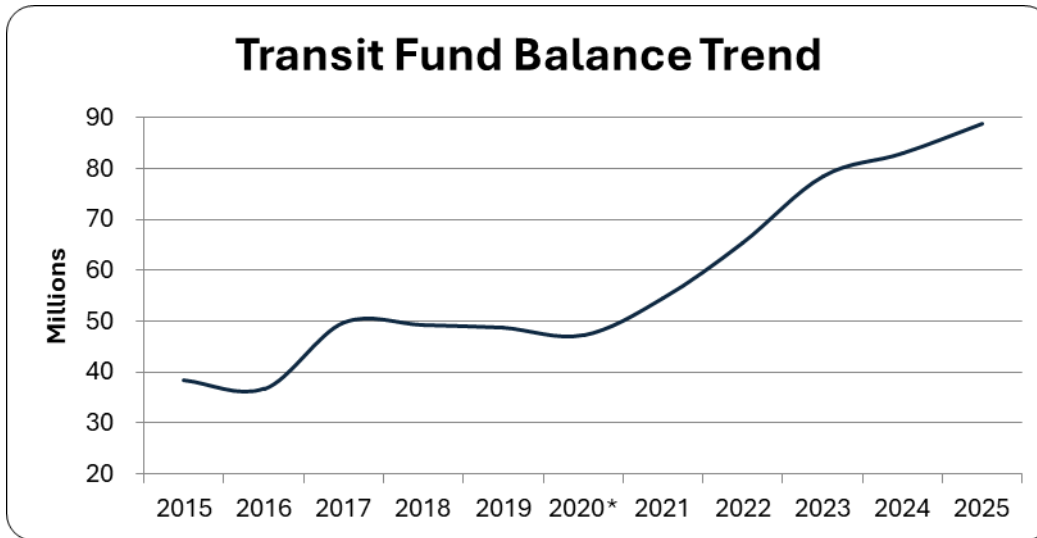

*Parking was separated from Transit Fund in 2020

	2020	2021	2022	2023	2024	2025
Operating Income	(14,073,650)	(12,730,336)	(8,583,043)	(21,645,265)	(22,901,131)	(21,325,960)
Nonoperating Revenues/Expenses & Transfers	12,742,936	19,931,054	19,576,032	34,695,810	27,251,492	27,190,851
Change in Net Position	(1,330,714)	7,200,718	10,992,989	13,050,545	4,350,361	5,864,891
Beginning Net Position	48,611,174	47,280,460	54,481,178	65,474,167	78,524,712	82,875,073
Ending Net Position	47,280,460	54,481,178	65,474,167	78,524,712	82,875,073	88,739,964
Net investment in capital assets	36,324,827	34,157,782	30,677,748	28,445,759	36,977,002	35,608,575
Unrestricted	10,955,633	20,323,396	34,796,419	50,078,953	45,898,071	53,131,389
Total Net Position	47,280,460	54,481,178	65,474,167	78,524,712	82,875,073	88,739,964

General Fund Reserves/Fund Balance

Despite a challenging winter season and broader economic uncertainty, Park City’s overall fiscal position remains strong due to our robust fund balance that trends near the maximum level allowed by state law (35%).

Our fund balance provides a significant cushion should we experience an economic downturn. This proactive posture safeguards our operational stability, however, the reliance on seasonal and tourism-driven revenue streams requires a disciplined approach to expenditure management. Because sales and lodging taxes are subject to seasonal and economic shifts, our primary focus remains on aligning recurring revenues with recurring expenses when possible, and reserving fund balance for emergencies, one-time expenses, or addressing short-term revenue gaps.

Exhibits

- A Departmental Operating Budget Report*
- B FY27 Operating Budget Requests*
- C FY27 Capital Budget Requests*

NEXT YEAR BUDGET HISTORICAL COMPARISON

PROJECTION: 20276 Tentative Budget - Full Upload FOR PERIOD 13

ACCOUNTS FOR:

General Fund	PRIOR FY3 ACTUALS	PRIOR FY2 ACTUALS	LAST FY1 ACTUALS	CY ACTUALS	CY REV BUDGET	PROJECTION LEVEL 4	PCT CHANGE
40011 City Council							
Salaries & Benefits	335,144.15	351,054.41	355,422.72	375,658.20	389,355.35	595,973.19	53.1%
Supplies, Main & Srv	104,994.60	113,545.55	149,227.49	117,353.62	112,028.00	151,028.00	34.8%
Energy & Utilities	4,166.11	4,750.08	4,647.36	4,223.20	6,200.00	6,200.00	.0%
City Council	444,304.86	469,350.04	509,297.57	497,235.02	507,583.35	753,201.19	48.4%
40021 City Manager							
Salaries & Benefits	1,315,327.87	1,383,719.84	1,352,447.87	1,162,835.33	1,568,001.51	1,583,410.44	1.0%
Supplies, Main & Srv	123,814.02	118,184.52	85,554.87	140,306.47	295,499.00	295,499.00	.0%
Energy & Utilities	6,679.87	7,712.27	9,099.09	4,385.92	6,621.00	6,621.00	.0%
City Manager	1,445,821.76	1,509,616.63	1,447,101.83	1,307,527.72	1,870,121.51	1,885,530.44	.8%
40023 Elections							
Supplies, Main & Srv	.00	24,554.25	.00	32,319.81	45,000.00	5,000.00	-88.9%
Elections	.00	24,554.25	.00	32,319.81	45,000.00	5,000.00	-88.9%
40031 City Attorney							
Salaries & Benefits	1,529,677.24	1,758,159.65	1,762,013.37	1,505,369.75	1,944,493.57	1,960,789.39	.8%
Supplies, Main & Srv	77,446.01	74,330.09	63,597.85	80,419.21	85,800.00	128,400.00	49.7%
Energy & Utilities	4,898.70	4,295.48	6,109.15	2,613.19	4,250.00	4,250.00	.0%
Capital Outlay	10,381.12	647.97	1,957.26	.00	10,600.00	10,600.00	.0%
City Attorney	1,622,403.07	1,837,433.19	1,833,677.63	1,588,402.15	2,045,143.57	2,104,039.39	2.9%
40034 Budget Debt & Grants							
Salaries & Benefits	561,210.26	703,333.89	870,273.55	730,527.00	938,563.28	950,198.71	1.2%
Supplies, Main & Srv	38,142.61	47,981.44	47,660.59	75,129.20	50,800.00	50,800.00	.0%
Energy & Utilities	2,969.55	3,721.31	2,152.60	1,866.28	2,600.00	2,600.00	.0%
Budget Debt & Grants	602,322.42	755,036.64	920,086.74	807,522.48	991,963.28	1,003,598.71	1.2%
40062 Human Resources							

NEXT YEAR BUDGET HISTORICAL COMPARISON

PROJECTION: 20276 Tentative Budget - Full Upload FOR PERIOD 13

ACCOUNTS FOR:

General Fund	PRIOR FY3 ACTUALS	PRIOR FY2 ACTUALS	LAST FY1 ACTUALS	CY ACTUALS	CY REV BUDGET	PROJECTION LEVEL 4	PCT CHANGE
Salaries & Benefits	739,266.66	898,951.54	959,138.12	821,350.22	1,142,909.17	1,156,872.77	1.2%
Supplies, Main & Srv	317,819.76	401,551.81	320,004.44	247,293.43	361,450.00	368,950.00	2.1%
Energy & Utilities	4,453.24	3,122.08	3,578.87	2,146.74	5,300.00	5,300.00	.0%
Capital Outlay	643.72	245.75	.00	489.99	3,000.00	3,000.00	.0%
Human Resources	1,062,183.38	1,303,871.18	1,282,721.43	1,071,280.38	1,512,659.17	1,534,122.77	1.4%
40072 Finance							
Salaries & Benefits	866,589.46	996,631.69	1,039,986.43	895,719.77	1,167,287.41	1,183,579.18	1.4%
Supplies, Main & Srv	168,314.94	177,030.27	145,758.08	136,194.80	188,849.93	188,849.93	.0%
Energy & Utilities	1,219.36	1,420.14	1,632.48	1,504.40	3,400.00	3,400.00	.0%
Finance	1,036,123.76	1,175,082.10	1,187,376.99	1,033,418.97	1,359,537.34	1,375,829.11	1.2%
40082 Information Technology							
Salaries & Benefits	1,416,489.97	1,772,881.61	1,750,035.05	1,618,354.40	2,269,112.06	2,298,787.07	1.3%
Supplies, Main & Srv	1,073,760.07	1,201,740.22	1,219,810.60	1,177,831.47	1,242,300.00	1,242,300.00	.0%
Energy & Utilities	126,263.35	137,369.47	118,966.99	94,901.92	94,200.00	94,200.00	.0%
Capital Outlay	86,272.98	21,485.28	5,361.16	4,750.24	28,900.00	28,900.00	.0%
Transfers Out	3,750.00	1,750.00	1,100.00	910.00	1,100.00	1,100.00	.0%
Information Technology	2,706,536.37	3,135,226.58	3,095,273.80	2,896,748.03	3,635,612.06	3,665,287.07	.8%
40091 Building Maintenance							
Salaries & Benefits	900,289.17	859,190.52	961,454.89	800,116.29	1,238,033.42	1,258,746.48	1.7%
Supplies, Main & Srv	803,178.04	811,169.03	942,209.19	757,809.20	798,615.40	784,387.49	-1.8%
Energy & Utilities	192,283.04	199,507.37	168,675.02	111,847.58	195,617.00	197,151.00	.8%
Capital Outlay	.00	48,395.00	.00	.00	.00	.00	.0%
Transfers Out	21,500.00	17,800.00	30,500.00	25,420.00	30,500.00	30,500.00	.0%
Building Maintenance	1,917,250.25	1,936,061.92	2,102,839.10	1,695,193.07	2,262,765.82	2,270,784.97	.4%
40092 PC MARC							

NEXT YEAR BUDGET HISTORICAL COMPARISON

PROJECTION: 20276 Tentative Budget - Full Upload FOR PERIOD 13

ACCOUNTS FOR:

General Fund	PRIOR FY3 ACTUALS	PRIOR FY2 ACTUALS	LAST FY1 ACTUALS	CY ACTUALS	CY REV BUDGET	PROJECTION LEVEL 4	PCT CHANGE
Salaries & Benefits	1,196,150.94	1,472,199.28	1,599,314.47	1,219,167.35	1,457,064.31	1,472,410.45	1.1%
Supplies, Main & Srv	269,110.06	357,551.62	448,368.36	211,331.77	439,230.00	446,530.00	1.7%
Energy & Utilities	236,594.45	261,188.24	266,157.08	142,518.76	281,373.00	281,373.00	.0%
Capital Outlay	15,538.38	5,614.88	6,556.42	10,785.27	14,400.00	14,400.00	.0%
Transfers Out	5,500.00	7,000.00	6,000.00	5,000.00	6,000.00	6,000.00	.0%
PC MARC	1,722,893.83	2,103,554.02	2,326,396.33	1,588,803.15	2,198,067.31	2,220,713.45	1.0%
40093 Racquet Sports							
Salaries & Benefits	740,461.09	884,188.44	1,069,964.71	950,476.42	1,355,310.44	1,377,408.63	1.6%
Supplies, Main & Srv	102,164.81	131,466.60	141,312.30	130,431.62	197,150.00	241,150.00	22.3%
Energy & Utilities	596.17	679.92	1,090.00	391.49	1,300.00	1,300.00	.0%
Capital Outlay	1,849.28	628.86	651.66	.00	.00	.00	.0%
Racquet Sports	845,071.35	1,016,963.82	1,213,018.67	1,081,299.53	1,553,760.44	1,619,858.63	4.3%
40094 McPolin Farm							
Salaries & Benefits	24,419.81	51,899.63	52,359.38	42,438.24	52,652.19	53,536.38	1.7%
Supplies, Main & Srv	10,999.15	12,451.48	14,435.87	6,240.14	13,300.00	13,300.00	.0%
Energy & Utilities	6,810.23	6,512.32	5,136.37	2,710.28	7,003.00	7,003.00	.0%
McPolin Farm	42,229.19	70,863.43	71,931.62	51,388.66	72,955.19	73,839.38	1.2%
40098 Recreation Programs							
Salaries & Benefits	864,219.42	845,544.76	922,794.90	807,759.32	1,167,430.17	1,362,921.95	16.7%
Supplies, Main & Srv	57,733.24	63,545.31	75,308.74	42,161.77	95,620.00	95,620.00	.0%
Recreation Programs	921,952.66	909,090.07	998,103.64	849,921.09	1,263,050.17	1,458,541.95	15.5%
40100 Community Engagement							
Salaries & Benefits	519,211.10	589,048.09	638,683.00	702,659.79	700,662.47	793,469.09	13.2%
Supplies, Main & Srv	106,159.83	116,219.08	140,708.93	106,432.00	168,600.00	178,600.00	5.9%
Energy & Utilities	660.55	2,029.49	2,443.10	3,708.27	3,000.00	3,000.00	.0%
Capital Outlay	198.00	.00	.00	1,789.45	500.00	500.00	.0%

NEXT YEAR BUDGET HISTORICAL COMPARISON

PROJECTION: 20276 Tentative Budget - Full Upload FOR PERIOD 13

ACCOUNTS FOR:

General Fund	PRIOR FY3 ACTUALS	PRIOR FY2 ACTUALS	LAST FY1 ACTUALS	CY ACTUALS	CY REV BUDGET	PROJECTION LEVEL 4	PCT CHANGE
Community Engagement	626,229.48	707,296.66	781,835.03	814,589.51	872,762.47	975,569.09	11.8%
40101 Economy							
Salaries & Benefits	864,396.96	169,614.49	608,521.37	758,615.92	1,018,439.37	1,042,944.62	2.4%
Supplies, Main & Srv	615,410.52	100,301.99	197,108.57	95,783.30	279,950.00	279,950.00	.0%
Energy & Utilities	10,910.54	4,652.64	3,288.41	1,868.73	.00	.00	.0%
Capital Outlay Economy	34,838.07 1,525,556.09	2,475.12 277,044.24	264.83 809,183.18	912.74 857,180.69	3,200.00 1,301,589.37	3,200.00 1,326,094.62	.0% 1.9%
40102 Environmental Regulatory							
Salaries & Benefits	163,710.69	181,570.34	197,652.15	169,803.14	195,853.17	213,142.99	8.8%
Supplies, Main & Srv Environmental Regulator	141,954.37 305,665.06	168,116.34 349,686.68	234,736.57 432,388.72	36,503.57 206,306.71	210,000.00 405,853.17	210,000.00 423,142.99	.0% 4.3%
40104 Environmental Sustainability							
Salaries & Benefits	358,408.15	375,014.63	380,764.82	322,194.57	482,052.35	429,988.30	-10.8%
Supplies, Main & Srv	92,496.54	110,435.58	68,892.60	46,023.70	372,577.00	244,577.00	-34.4%
Energy & Utilities	505.75	850.46	2,549.07	2,030.80	.00	.00	.0%
Capital Outlay Environmental Sustaina	.00 451,410.44	1,738.28 488,038.95	756.23 452,962.72	.00 370,249.07	.00 854,629.35	.00 674,565.30	.0% -21.1%
40106 Special Events							
Salaries & Benefits	.00	506,377.11	519,185.29	362,488.50	486,167.94	493,148.39	1.4%
Supplies, Main & Srv	449.40	603,834.21	725,415.18	554,711.74	751,133.00	401,133.00	-46.6%
Energy & Utilities	.00	1,534.07	4,447.86	1,788.64	2,400.00	2,400.00	.0%
Capital Outlay Special Events	.00 449.40	50,407.29 1,162,152.68	.00 1,249,048.33	.00 918,988.88	.00 1,239,700.94	.00 896,681.39	.0% -27.7%
40111 Insurance & Security Bonds							
Transfers Out Insurance & Security B	980,030.00 980,030.00	1,026,307.00 1,026,307.00	1,070,699.00 1,070,699.00	944,130.00 944,130.00	1,132,955.00 1,132,955.00	1,022,446.40 1,022,446.40	-9.8% -9.8%

NEXT YEAR BUDGET HISTORICAL COMPARISON

PROJECTION: 20276 Tentative Budget - Full Upload FOR PERIOD 13

ACCOUNTS FOR:

General Fund	PRIOR FY3 ACTUALS	PRIOR FY2 ACTUALS	LAST FY1 ACTUALS	CY ACTUALS	CY REV BUDGET	PROJECTION LEVEL 4	PCT CHANGE
40118 Lead Training							
Supplies, Main & Srv Lead Training	5,141.14 5,141.14	.00 .00	.00 .00	.00 .00	.00 .00	.00 .00	.0% .0%
40122 SpecSrvCont Hist Soc Museum							
Supplies, Main & Srv SpecSrvCont Hist Soc	25,000.00 25,000.00	25,000.00 25,000.00	25,000.00 25,000.00	20,000.00 20,000.00	25,000.00 25,000.00	30,000.00 30,000.00	20.0% 20.0%
40124 SpecSrvCont Youth Adv							
Supplies, Main & Srv SpecSrvCont Youth Adv	.00 .00	370,000.00 370,000.00	515,312.50 515,312.50	605,000.00 605,000.00	633,000.00 633,000.00	685,000.00 685,000.00	8.2% 8.2%
40134 Senior Center Administration							
Supplies, Main & Srv Senior Center Administ	.00 .00	.00 .00	.00 .00	.00 .00	.00 .00	50,000.00 50,000.00	.0% .0%
40135 Special Service Contract							
Supplies, Main & Srv Special Service Contra	450,900.00 450,900.00	495,000.00 495,000.00	500,000.00 500,000.00	637,650.00 637,650.00	638,500.00 638,500.00	746,500.00 746,500.00	16.9% 16.9%
40136 Leadership							
Salaries & Benefits	5,206.87	5,193.89	6,927.95	3,472.79	5,070.00	5,070.00	.0%
Supplies, Main & Srv	65,966.34	65,296.29	66,832.04	31,016.20	62,500.00	62,500.00	.0%
Energy & Utilities	654.78	793.83	172.75	.00	800.00	800.00	.0%
Leadership	71,827.99	71,284.01	73,932.74	34,488.99	68,370.00	68,370.00	.0%
40146 Vacancy Factor							
Salaries & Benefits Vacancy Factor	.00 .00	.00 .00	.00 .00	.00 .00	-1,541,458.02 -1,541,458.02	-1,649,360.02 -1,649,360.02	7.0% 7.0%
40148 Emergency Management							
Salaries & Benefits	129,787.91	150,209.69	148,910.13	80,952.21	190,732.85	193,061.02	1.2%

NEXT YEAR BUDGET HISTORICAL COMPARISON

PROJECTION: 20276 Tentative Budget - Full Upload FOR PERIOD 13

ACCOUNTS FOR:

General Fund	PRIOR FY3 ACTUALS	PRIOR FY2 ACTUALS	LAST FY1 ACTUALS	CY ACTUALS	CY REV BUDGET	PROJECTION LEVEL 4	PCT CHANGE
Supplies, Main & Srv	168,932.79	42,343.14	38,863.19	26,247.98	42,500.00	42,500.00	.0%
Capital Outlay	35,590.52	39,595.35	76,391.57	21,799.51	75,000.00	75,000.00	.0%
Emergency Management	334,311.22	232,148.18	264,164.89	128,999.70	308,232.85	310,561.02	.8%
40149 Arts & Culture							
Salaries & Benefits	24,795.33	2,796.69	.00	.00	.00	.00	.0%
Supplies, Main & Srv	49,002.72	21,704.89	5,597.12	-2,237.35	.00	.00	.0%
Energy & Utilities	3,818.63	4,317.35	3,767.23	4,181.05	4,162.00	4,162.00	.0%
Arts & Culture	77,616.68	28,818.93	9,364.35	1,943.70	4,162.00	4,162.00	.0%
40150 Trails							
Salaries & Benefits	418,465.07	543,610.82	467,891.41	360,864.39	505,777.42	702,113.16	38.8%
Supplies, Main & Srv	207,216.29	248,381.90	329,229.71	122,868.08	337,100.00	332,100.00	-1.5%
Energy & Utilities	.00	3,539.44	4,591.53	3,087.81	2,800.00	2,800.00	.0%
Capital Outlay	28,379.57	550.21	1,265.40	.00	.00	65,000.00	.0%
Trails	654,060.93	796,082.37	802,978.05	486,820.28	845,677.42	1,102,013.16	30.3%
40151 Social Equity							
Salaries & Benefits	3,348.47	3,840.81	4,196.34	3,580.65	58,223.08	.00	-100.0%
Supplies, Main & Srv	14,924.62	10,828.17	27,448.67	25,801.91	6,479.00	6,479.00	.0%
Social Equity	18,273.09	14,668.98	31,645.01	29,382.56	64,702.08	6,479.00	-90.0%
40221 Police							
Salaries & Benefits	6,656,894.82	7,312,978.66	8,054,588.83	7,482,349.91	8,973,000.51	9,000,129.37	.3%
Supplies, Main & Srv	160,486.20	133,361.21	85,007.53	227,883.66	225,350.00	237,350.00	5.3%
Energy & Utilities	81,127.80	71,505.26	43,354.80	62,673.90	66,800.00	66,800.00	.0%
Capital Outlay	152,435.62	42,292.53	16,745.79	275,506.11	269,044.00	67,044.00	-75.1%
Transfers Out	270,000.00	242,000.00	218,000.00	181,670.00	218,000.00	218,000.00	.0%
Police	7,320,944.44	7,802,137.66	8,417,696.95	8,230,083.58	9,752,194.51	9,589,323.37	-1.7%
40222 Drug Education							

NEXT YEAR BUDGET HISTORICAL COMPARISON

PROJECTION: 20276 Tentative Budget - Full Upload FOR PERIOD 13

ACCOUNTS FOR:

General Fund	PRIOR FY3 ACTUALS	PRIOR FY2 ACTUALS	LAST FY1 ACTUALS	CY ACTUALS	CY REV BUDGET	PROJECTION LEVEL 4	PCT CHANGE
Salaries & Benefits	33,444.28	37,267.11	41,059.35	39,003.21	37,777.03	38,242.66	1.2%
Supplies, Main & Srv	.00	.00	147.58	.00	5,000.00	5,000.00	.0%
Drug Education	33,444.28	37,267.11	41,206.93	39,003.21	42,777.03	43,242.66	1.1%
40223 State Liquor Enforcement							
Salaries & Benefits	61,693.80	85,958.76	21,799.84	37,283.92	57,039.69	57,039.69	.0%
Supplies, Main & Srv	.00	.00	.00	.00	10,000.00	10,000.00	.0%
State Liquor Enforceme	61,693.80	85,958.76	21,799.84	37,283.92	67,039.69	67,039.69	.0%
40231 Communication Center							
Supplies, Main & Srv	739,739.84	766,634.26	790,881.06	818,220.08	807,163.00	828,923.00	2.7%
Energy & Utilities	1,309.35	1,479.63	1,681.62	1,164.71	.00	.00	.0%
Communication Center	741,049.19	768,113.89	792,562.68	819,384.79	807,163.00	828,923.00	2.7%
40240 SpecSrvCont Sister City Ad							
Supplies, Main & Srv	.00	8,550.00	22,104.71	9,430.00	8,550.00	8,550.00	.0%
SpecSrvCont Sister Ci	.00	8,550.00	22,104.71	9,430.00	8,550.00	8,550.00	.0%
40241 SpecSrvCont Trails Mgmt							
Supplies, Main & Srv	.00	.00	.00	.00	.01	.01	.0%
SpecSrvCont Trails Mg	.00	.00	.00	.00	.01	.01	.0%
40242 SpecSrvCont Waste Recycl Mgmt							
Supplies, Main & Srv	50,000.00	50,000.00	60,000.00	.00	50,000.00	75,000.00	50.0%
SpecSrvCont Waste Rec	50,000.00	50,000.00	60,000.00	.00	50,000.00	75,000.00	50.0%
40244 SpecSrvCont Legal Mediation							
Supplies, Main & Srv	15,375.00	16,143.75	8,268.75	.00	17,000.00	17,000.00	.0%
SpecSrvCont Legal Med	15,375.00	16,143.75	8,268.75	.00	17,000.00	17,000.00	.0%
40313 Engineering							
Salaries & Benefits	823,855.35	1,412,972.73	1,679,558.19	1,467,583.77	1,811,423.71	1,831,785.72	1.1%

NEXT YEAR BUDGET HISTORICAL COMPARISON

PROJECTION: 20276 Tentative Budget - Full Upload FOR PERIOD 13

ACCOUNTS FOR:

General Fund	PRIOR FY3 ACTUALS	PRIOR FY2 ACTUALS	LAST FY1 ACTUALS	CY ACTUALS	CY REV BUDGET	PROJECTION LEVEL 4	PCT CHANGE
Supplies, Main & Srv	138,609.10	129,200.40	209,692.68	236,796.55	149,700.00	149,700.00	.0%
Energy & Utilities	6,644.09	6,796.66	8,099.30	4,087.89	4,100.00	4,100.00	.0%
Capital Outlay	1,954.48	37,516.22	472.41	100.44	3,000.00	60,000.00	1900.0%
Engineering	971,063.02	1,586,486.01	1,897,822.58	1,708,568.65	1,968,223.71	2,045,585.72	3.9%
40342 Planning							
Salaries & Benefits	1,245,851.52	1,270,897.18	1,465,719.46	1,413,833.58	2,050,529.12	1,918,592.64	-6.4%
Supplies, Main & Srv	152,233.17	443,926.87	547,928.72	153,279.92	263,499.89	242,500.00	-8.0%
Energy & Utilities	8,644.30	14,185.09	12,623.79	8,353.12	8,600.00	8,600.00	.0%
Capital Outlay	50.54	45.21	.00	.00	4,000.00	4,000.00	.0%
Planning	1,406,779.53	1,729,054.35	2,026,271.97	1,575,466.62	2,326,629.01	2,173,692.64	-6.6%
40352 Building							
Salaries & Benefits	2,003,303.80	2,145,152.14	2,453,768.99	2,018,639.94	2,847,383.32	2,889,290.55	1.5%
Supplies, Main & Srv	70,407.18	70,888.45	57,376.23	43,045.55	89,704.00	89,704.00	.0%
Energy & Utilities	13,960.75	16,578.25	11,923.33	11,310.70	14,250.00	14,250.00	.0%
Capital Outlay	138,703.38	78,348.09	3,619.75	2,244.29	7,100.00	7,100.00	.0%
Transfers Out	71,500.00	71,500.00	70,750.00	58,960.00	70,750.00	70,750.00	.0%
Building	2,297,875.11	2,382,466.93	2,597,438.30	2,134,200.48	3,029,187.32	3,071,094.55	1.4%
40412 Parks & Cemetery							
Salaries & Benefits	1,735,892.68	1,829,858.90	2,049,049.04	1,738,221.10	2,328,941.48	2,358,732.43	1.3%
Supplies, Main & Srv	382,543.00	409,208.91	365,044.30	248,136.62	448,839.00	445,459.00	-.8%
Energy & Utilities	44,280.49	36,453.52	31,873.48	23,217.66	43,666.00	43,127.00	-1.2%
Capital Outlay	17,255.10	22,025.35	22,764.80	4,681.68	22,793.00	22,793.00	.0%
Transfers Out	218,000.00	191,500.00	151,500.00	126,250.00	151,500.00	151,500.00	.0%
Parks & Cemetery	2,397,971.27	2,489,046.68	2,620,231.62	2,140,507.06	2,995,739.48	3,021,611.43	.9%
40421 Street Maintenance							

NEXT YEAR BUDGET HISTORICAL COMPARISON

PROJECTION: 20276 Tentative Budget - Full Upload FOR PERIOD 13

ACCOUNTS FOR:

General Fund	PRIOR FY3 ACTUALS	PRIOR FY2 ACTUALS	LAST FY1 ACTUALS	CY ACTUALS	CY REV BUDGET	PROJECTION LEVEL 4	PCT CHANGE
Salaries & Benefits	1,856,011.58	1,865,901.57	2,153,461.13	1,849,626.34	2,448,135.30	2,486,768.69	1.6%
Supplies, Main & Srv	583,239.55	540,803.55	452,369.68	228,789.87	564,897.00	562,102.00	-.5%
Energy & Utilities	41,590.98	34,412.32	31,436.25	22,497.45	47,200.00	37,500.00	-20.6%
Capital Outlay	93.06	146,768.21	276.97	579.00	9,000.00	9,000.00	.0%
Transfers Out	657,000.00	663,000.00	552,500.00	460,420.00	552,500.00	552,500.00	.0%
Street Maintenance	3,137,935.17	3,250,885.65	3,190,044.03	2,561,912.66	3,621,732.30	3,647,870.69	.7%
40423 Street Lights Sign							
Supplies, Main & Srv	84,251.25	64,197.21	84,774.59	64,660.42	76,800.00	76,800.00	.0%
Energy & Utilities	37,306.94	31,297.98	31,740.14	19,068.43	33,512.00	33,512.00	.0%
Capital Outlay	42,353.00	20,796.39	9,853.35	3,793.32	55,000.00	55,000.00	.0%
Street Lights Sign	163,911.19	116,291.58	126,368.08	87,522.17	165,312.00	165,312.00	.0%
40424 Swede Alley Parking Structure							
Supplies, Main & Srv	5,086.18	682.17	1,865.52	1,305.51	12,600.00	12,600.00	.0%
Energy & Utilities	35,388.48	38,603.43	33,350.70	22,938.80	36,800.00	36,800.00	.0%
Capital Outlay	.00	.00	3,644.14	2,084.12	4,500.00	4,500.00	.0%
Swede Alley Parking St	40,474.66	39,285.60	38,860.36	26,328.43	53,900.00	53,900.00	.0%
40551 Library							
Salaries & Benefits	1,433,331.04	1,670,393.64	1,665,397.35	1,451,762.48	1,950,458.71	1,988,736.33	2.0%
Supplies, Main & Srv	244,423.29	250,804.17	251,877.77	222,534.83	285,894.00	301,442.00	5.4%
Energy & Utilities	79,565.34	85,674.32	71,996.42	51,576.57	87,300.00	87,300.00	.0%
Capital Outlay	18,618.03	23,843.42	21,386.90	14,832.87	22,930.00	27,930.00	21.8%
Library	1,775,937.70	2,030,715.55	2,010,658.44	1,740,706.75	2,346,582.71	2,405,408.33	2.5%
40621 RDA Operations							
Supplies, Main & Srv	918,667.22	579,668.77	679,298.39	846,275.83	700,000.00	700,000.00	.0%
RDA Operations	918,667.22	579,668.77	679,298.39	846,275.83	700,000.00	700,000.00	.0%
40821 Transfer To Other Fund							

NEXT YEAR BUDGET HISTORICAL COMPARISON

PROJECTION: 20276 Tentative Budget - Full Upload FOR PERIOD 13

ACCOUNTS FOR:

General Fund	PRIOR FY3 ACTUALS	PRIOR FY2 ACTUALS	LAST FY1 ACTUALS	CY ACTUALS	CY REV BUDGET	PROJECTION LEVEL 4	PCT CHANGE
Transfers Out	3,610,600.00	1,910,600.00	1,910,600.00	1,592,160.00	1,910,600.00	1,910,600.00	.0%
Transfer To Other Fund	3,610,600.00	1,910,600.00	1,910,600.00	1,592,160.00	1,910,600.00	1,910,600.00	.0%
40981 Contingency General							
Supplies, Main & Srv Contingency General	36,300.00	31,798.29	8,286.38	8,000.00	100,000.00	.00	-100.0%
	36,300.00	31,798.29	8,286.38	8,000.00	100,000.00	.00	-100.0%
40985 Contingency Snow Removal							
Supplies, Main & Srv Contingency Snow Remov	.00	60,000.00	45,000.00	.00	50,000.00	.00	-100.0%
	.00	60,000.00	45,000.00	.00	50,000.00	.00	-100.0%
40986 Contingency Council							
Supplies, Main & Srv Contingency Council	.00	.00	.00	.00	50,000.00	.00	-100.0%
	.00	.00	.00	.00	50,000.00	.00	-100.0%
40990 Contingency Emergency							
Supplies, Main & Srv Contingency Emergency	.00	.00	.00	.00	50,000.00	.00	-100.0%
	.00	.00	.00	.00	50,000.00	.00	-100.0%
42180 Sundance Mitigation							
Supplies, Main & Srv Sundance Mitigation	319,246.00	368,434.00	369,722.00	-369,722.00	376,250.00	.00	-100.0%
	319,246.00	368,434.00	369,722.00	-369,722.00	376,250.00	.00	-100.0%
42181 Economic Development Grant							
Supplies, Main & Srv Economic Development G	.00	.00	10,000.00	10,000.00	10,000.00	.00	-100.0%
	.00	.00	10,000.00	10,000.00	10,000.00	.00	-100.0%
42182 Public Art							
Supplies, Main & Srv Public Art	2,897.66	15,888.34	4,570.93	845.52	7,000.00	47,000.00	571.4%
	2,897.66	15,888.34	4,570.93	845.52	7,000.00	47,000.00	571.4%
42183 Mental Health							
Supplies, Main & Srv Mental Health	73,042.00	138,500.00	138,500.00	.00	.00	.00	.0%
	73,042.00	138,500.00	138,500.00	.00	.00	.00	.0%

NEXT YEAR BUDGET HISTORICAL COMPARISON

PROJECTION: 20276 Tentative Budget - Full Upload FOR PERIOD 13

ACCOUNTS FOR:

General Fund	PRIOR FY3 ACTUALS	PRIOR FY2 ACTUALS	LAST FY1 ACTUALS	CY ACTUALS	CY REV BUDGET	PROJECTION LEVEL 4	PCT CHANGE
42190 Marsac-Swede Condo HOA							
Supplies, Main & Srv Marsac-Swede Condo HOA	14,400.00 14,400.00	13,200.00 13,200.00	15,600.00 15,600.00	14,064.00 14,064.00	13,000.00 13,000.00	13,000.00 13,000.00	.0% .0%
42305 Abatement							
Supplies, Main & Srv Abatement	.00 .00	.00 .00	.00 .00	.00 .00	48,688.00 48,688.00	.00 .00	-100.0% -100.0%
42310 Historical Incentive Grant							
Supplies, Main & Srv Historical Incentive G	11,790.00 11,790.00	33,736.00 33,736.00	18,500.00 18,500.00	.00 .00	47,136.00 47,136.00	47,136.00 47,136.00	.0% .0%
43000 Converted Fixed Asset							
Capital Outlay Converted Fixed Asset	391,481.00 391,481.00	.00 .00	.00 .00	.00 .00	.00 .00	.00 .00	.0% .0%
43010 Business Improvement District							
Supplies, Main & Srv Business Improvement D	64,395.00 64,395.00	.00 .00	.00 .00	.00 .00	64,419.00 64,419.00	64,419.00 64,419.00	.0% .0%
43015 Internal Utilities Transfer							
Energy & Utilities Internal Utilities Tra TOTAL General Fund	715,000.00 715,000.00 46,467,837.66	1,051,810.00 1,051,810.00 48,886,271.47	1,051,810.00 1,051,810.00 52,129,562.81	.00 .00 43,768,811.82	1,051,810.00 1,051,810.00 57,902,829.61	1,051,810.00 1,051,810.00 57,690,091.10	.0% .0% -.4%

NEXT YEAR BUDGET HISTORICAL COMPARISON

PROJECTION: 20276 Tentative Budget - Full Upload FOR PERIOD 13

ACCOUNTS FOR:

Quinns Recreation Complex	PRIOR FY3 ACTUALS	PRIOR FY2 ACTUALS	LAST FY1 ACTUALS	CY ACTUALS	CY REV BUDGET	PROJECTION LEVEL 4	PCT CHANGE
40095 Ice Facility							
Salaries & Benefits	855,528.74	923,944.81	913,650.23	749,938.10	1,059,610.13	1,068,921.45	.9%
Supplies, Main & Srv	177,274.86	205,569.47	230,154.05	183,703.15	295,095.00	295,095.00	.0%
Energy & Utilities	148,685.33	145,556.94	150,342.05	102,912.51	149,962.00	157,189.00	4.8%
Capital Outlay	.00	.00	.00	.00	5,000.00	1,000.00	-80.0%
Ice Facility	1,181,488.93	1,275,071.22	1,294,146.33	1,036,553.76	1,509,667.13	1,522,205.45	.8%
40096 Fields							
Salaries & Benefits	206,850.73	208,579.38	200,401.56	180,968.21	305,842.02	310,495.65	1.5%
Supplies, Main & Srv	35,811.65	37,265.53	44,818.99	26,180.12	45,300.00	45,433.00	.3%
Energy & Utilities	18,047.45	18,735.87	16,149.60	14,116.62	12,797.00	13,958.00	9.1%
Fields	260,709.83	264,580.78	261,370.15	221,264.95	363,939.02	369,886.65	1.6%
TOTAL Quinns Recreation Comp	1,442,198.76	1,539,652.00	1,555,516.48	1,257,818.71	1,873,606.15	1,892,092.10	1.0%

NEXT YEAR BUDGET HISTORICAL COMPARISON

PROJECTION: 20276 Tentative Budget - Full Upload FOR PERIOD 13

ACCOUNTS FOR:

Criminal Forfeiture	PRIOR FY3 ACTUALS	PRIOR FY2 ACTUALS	LAST FY1 ACTUALS	CY ACTUALS	CY REV BUDGET	PROJECTION LEVEL 4	PCT CHANGE
41001 Police Special Revenue							
Capital Outlay	3,021.14	11,955.48	31,689.05	.00	.00	.00	.0%
Police Special Revenue	3,021.14	11,955.48	31,689.05	.00	.00	.00	.0%
TOTAL Criminal Forfeiture	3,021.14	11,955.48	31,689.05	.00	.00	.00	.0%

NEXT YEAR BUDGET HISTORICAL COMPARISON

PROJECTION: 20276 Tentative Budget - Full Upload FOR PERIOD 13

ACCOUNTS FOR:

Lower Park Ave RDA Special Rev	PRIOR FY3 ACTUALS	PRIOR FY2 ACTUALS	LAST FY1 ACTUALS	CY ACTUALS	CY REV BUDGET	PROJECTION LEVEL 4	PCT CHANGE
40624 LPA RDA Mitigation							
Supplies, Main & Srv LPA RDA Mitigation	693,937.42 693,937.42	699,065.14 699,065.14	863,759.36 863,759.36	.00 .00	750,000.00 750,000.00	750,000.00 750,000.00	.0% .0%
42310 Historical Incentive Grant							
Supplies, Main & Srv Historical Incentive G	11,400.00 11,400.00	38,600.00 38,600.00	.00 .00	.00 .00	50,000.00 50,000.00	50,000.00 50,000.00	.0% .0%
43328 Lower Park Avenue RDA							
Supplies, Main & Srv	.00	.00	.00	.00	30,000.00	30,000.00	.0%
Energy & Utilities	2,977.99	5,430.46	2,278.68	-27.42	5,823.00	5,823.00	.0%
Transfers Out	3,092,532.00	3,092,532.00	3,092,532.00	2,577,110.00	3,092,532.00	3,092,532.00	.0%
Lower Park Avenue RDA	3,095,509.99	3,097,962.46	3,094,810.68	2,577,082.58	3,128,355.00	3,128,355.00	.0%
TOTAL Lower Park Ave RDA Spe	3,800,847.41	3,835,627.60	3,958,570.04	2,577,082.58	3,928,355.00	3,928,355.00	.0%

NEXT YEAR BUDGET HISTORICAL COMPARISON

PROJECTION: 20276 Tentative Budget - Full Upload FOR PERIOD 13

ACCOUNTS FOR:

Main Street RDA Special Rev	PRIOR FY3 ACTUALS	PRIOR FY2 ACTUALS	LAST FY1 ACTUALS	CY ACTUALS	CY REV BUDGET	PROJECTION LEVEL 4	PCT CHANGE
40623 Main Street RDA Mitigation							
Supplies, Main & Srv	230,162.72	.00	.00	.00	.00	.00	.0%
Main Street RDA Mitiga	230,162.72	.00	.00	.00	.00	.00	.0%
42310 Historical Incentive Grant							
Supplies, Main & Srv	6,830.00	30,000.00	7,300.00	.00	30,000.00	30,000.00	.0%
Historical Incentive G	6,830.00	30,000.00	7,300.00	.00	30,000.00	30,000.00	.0%
43303 Main Street RDA							
Supplies, Main & Srv	.00	.00	.00	.00	20,000.00	20,000.00	.0%
Transfers Out	400,000.00	.00	.00	.00	.00	.00	.0%
Main Street RDA	400,000.00	.00	.00	.00	20,000.00	20,000.00	.0%
TOTAL Main Street RDA Specia	636,992.72	30,000.00	7,300.00	.00	50,000.00	50,000.00	.0%

NEXT YEAR BUDGET HISTORICAL COMPARISON

PROJECTION: 20276 Tentative Budget - Full Upload FOR PERIOD 13

ACCOUNTS FOR:

Capital Improvement Fund	PRIOR FY3 ACTUALS	PRIOR FY2 ACTUALS	LAST FY1 ACTUALS	CY ACTUALS	CY REV BUDGET	PROJECTION LEVEL 4	PCT CHANGE
40821 Transfer To Other Fund							
Transfers Out	4,177,076.00	4,174,476.00	4,176,426.00	3,479,190.00	4,175,025.00	4,175,025.00	.0%
Transfer To Other Fund	4,177,076.00	4,174,476.00	4,176,426.00	3,479,190.00	4,175,025.00	4,175,025.00	.0%
TOTAL Capital Improvement Fu	4,177,076.00	4,174,476.00	4,176,426.00	3,479,190.00	4,175,025.00	4,175,025.00	.0%

NEXT YEAR BUDGET HISTORICAL COMPARISON

PROJECTION: 20276 Tentative Budget - Full Upload FOR PERIOD 13

ACCOUNTS FOR:

Lower Park Ave RDA Capital Fnd	PRIOR FY3 ACTUALS	PRIOR FY2 ACTUALS	LAST FY1 ACTUALS	CY ACTUALS	CY REV BUDGET	PROJECTION LEVEL 4	PCT CHANGE
40821 Transfer To Other Fund							
Transfers Out	2,791,715.00	2,790,840.00	2,790,840.00	2,316,320.00	2,779,590.00	2,779,590.00	.0%
Transfer To Other Fund	2,791,715.00	2,790,840.00	2,790,840.00	2,316,320.00	2,779,590.00	2,779,590.00	.0%
TOTAL Lower Park Ave RDA Cap	2,791,715.00	2,790,840.00	2,790,840.00	2,316,320.00	2,779,590.00	2,779,590.00	.0%

NEXT YEAR BUDGET HISTORICAL COMPARISON

PROJECTION: 20276 Tentative Budget - Full Upload FOR PERIOD 13

ACCOUNTS FOR:

Water Fund	PRIOR FY3 ACTUALS	PRIOR FY2 ACTUALS	LAST FY1 ACTUALS	CY ACTUALS	CY REV BUDGET	PROJECTION LEVEL 4	PCT CHANGE
40451 Water Operations							
Salaries & Benefits	4,404,231.07	5,283,812.09	5,281,408.95	4,431,088.31	5,185,227.92	5,251,565.49	1.3%
Supplies, Main & Srv	3,966,745.77	5,513,779.18	4,979,552.94	3,093,262.25	5,974,408.99	6,276,898.29	5.1%
Energy & Utilities	850,567.76	837,493.85	738,173.41	539,178.91	1,142,600.00	1,142,600.00	.0%
Capital Outlay	15,924.19	13,963.21	15,288.88	2,601.73	43,000.00	43,000.00	.0%
Transfers Out	1,928,713.00	2,373,294.00	2,415,973.00	1,183,510.00	2,472,019.00	2,158,298.50	-12.7%
Water Operations	11,166,181.79	14,022,342.33	13,430,397.18	9,249,641.20	14,817,255.91	14,872,362.28	.4%
40452 Water Insurance							
Transfers Out	162,278.00	211,355.00	224,010.00	209,360.00	251,234.00	365,977.92	45.7%
Water Insurance	162,278.00	211,355.00	224,010.00	209,360.00	251,234.00	365,977.92	45.7%
40484 Depreciation							
Depreciation & Amort	4,196,690.00	4,571,070.00	6,341,039.67	.00	.00	.00	.0%
Depreciation	4,196,690.00	4,571,070.00	6,341,039.67	.00	.00	.00	.0%
40575 Pension Expense GASB 68							
Salaries & Benefits	-263,738.00	-221,785.00	268,099.00	.00	.00	.00	.0%
Pension Expense GASB 6	-263,738.00	-221,785.00	268,099.00	.00	.00	.00	.0%
40740 2009A Water Revenue Bonds DEQ							
Debt Service	2,500.00	2,500.00	2,500.00	127,500.00	127,500.00	127,500.00	.0%
2009A Water Revenue Bo	2,500.00	2,500.00	2,500.00	127,500.00	127,500.00	127,500.00	.0%
40746 2013A Water Revenue Bonds							
Debt Service	16,761.00	11,805.53	6,752.53	267,470.00	270,150.00	270,150.00	.0%
2013A Water Revenue Bo	16,761.00	11,805.53	6,752.53	267,470.00	270,150.00	270,150.00	.0%
40748 2014 Water Revenue Bonds							
Debt Service	115,101.50	117,201.43	114,019.43	24,250.25	1,824,862.00	1,824,862.00	.0%
2014 Water Revenue Bon	115,101.50	117,201.43	114,019.43	24,250.25	1,824,862.00	1,824,862.00	.0%

NEXT YEAR BUDGET HISTORICAL COMPARISON

PROJECTION: 20276 Tentative Budget - Full Upload FOR PERIOD 13

ACCOUNTS FOR:

Water Fund	PRIOR FY3 ACTUALS	PRIOR FY2 ACTUALS	LAST FY1 ACTUALS	CY ACTUALS	CY REV BUDGET	PROJECTION LEVEL 4	PCT CHANGE
40750 2020 Water Revenue Bonds							
Debt Service	1,753,336.78	-684,190.75	1,615,754.26	975,550.88	2,137,344.00	2,137,344.00	.0%
2020 Water Revenue Bon	1,753,336.78	-684,190.75	1,615,754.26	975,550.88	2,137,344.00	2,137,344.00	.0%
40755 2021 Water Revenue Bonds							
Debt Service	1,803,142.26	4,015,230.41	1,573,656.41	4,128,517.63	5,045,381.00	5,045,381.00	.0%
2021 Water Revenue Bon	1,803,142.26	4,015,230.41	1,573,656.41	4,128,517.63	5,045,381.00	5,045,381.00	.0%
40820 Contracts Payable							
Debt Service	25,361.20	49,345.33	73,279.11	-22,581.63	.00	.00	.0%
Contracts Payable	25,361.20	49,345.33	73,279.11	-22,581.63	.00	.00	.0%
40825 Right To Use Asset							
Debt Service	84,524.62	84,524.62	84,524.62	.00	.00	.00	.0%
Right To Use Asset	84,524.62	84,524.62	84,524.62	.00	.00	.00	.0%
40900 Capital Asset-Period 13 Adj							
Capital Outlay	-18,874,441.00	-13,266,720.00	-3,786,711.80	.00	.00	.00	.0%
Capital Asset-Period 1	-18,874,441.00	-13,266,720.00	-3,786,711.80	.00	.00	.00	.0%
43428 Water Infrastructure Impr							
Salaries & Benefits	6,674.93	823.59	.00	.00	.00	.00	.0%
Water Infrastructure I	6,674.93	823.59	.00	.00	.00	.00	.0%
TOTAL Water Fund	194,373.08	8,913,502.49	19,947,320.41	14,959,708.33	24,473,726.91	24,643,577.20	.7%

NEXT YEAR BUDGET HISTORICAL COMPARISON

PROJECTION: 20276 Tentative Budget - Full Upload FOR PERIOD 13

ACCOUNTS FOR:

Stormwater Fund	PRIOR FY3 ACTUALS	PRIOR FY2 ACTUALS	LAST FY1 ACTUALS	CY ACTUALS	CY REV BUDGET	PROJECTION LEVEL 4	PCT CHANGE
40455 Stormwater Operations							
Salaries & Benefits	717,559.89	604,310.64	623,273.29	512,584.68	893,844.65	905,833.22	1.3%
Supplies, Main & Srv	103,299.60	117,926.78	222,849.95	47,185.74	254,531.00	254,531.00	.0%
Energy & Utilities	36,788.13	45,452.42	33,665.18	22,914.86	46,099.00	46,099.00	.0%
Capital Outlay	.00	703.63	.00	.00	1,500.00	1,500.00	.0%
Transfers out	164,627.00	173,153.00	195,018.00	168,650.00	202,395.00	144,157.01	-28.8%
Stormwater Operations	1,022,274.62	941,546.47	1,074,806.42	751,335.28	1,398,369.65	1,352,120.23	-3.3%
40484 Depreciation							
Depreciation & Amort	173,616.00	506,285.00	185,808.02	.00	.00	.00	.0%
Depreciation	173,616.00	506,285.00	185,808.02	.00	.00	.00	.0%
40575 Pension Expense GASB 68							
Salaries & Benefits	-78,123.00	-29,694.00	98,212.00	.00	.00	.00	.0%
Pension Expense GASB 6	-78,123.00	-29,694.00	98,212.00	.00	.00	.00	.0%
40900 Capital Asset-Period 13 Adj							
Capital Outlay	-18,831.00	-416,611.34	-32,619.00	.00	.00	.00	.0%
Capital Asset-Period 1	-18,831.00	-416,611.34	-32,619.00	.00	.00	.00	.0%
TOTAL Stormwater Fund	1,098,936.62	1,001,526.13	1,326,207.44	751,335.28	1,398,369.65	1,352,120.23	-3.3%

NEXT YEAR BUDGET HISTORICAL COMPARISON

PROJECTION: 20276 Tentative Budget - Full Upload FOR PERIOD 13

ACCOUNTS FOR:

Golf Course Fund	PRIOR FY3 ACTUALS	PRIOR FY2 ACTUALS	LAST FY1 ACTUALS	CY ACTUALS	CY REV BUDGET	PROJECTION LEVEL 4	PCT CHANGE
40484 Depreciation							
Depreciation & Amort	210,152.00	211,656.00	226,992.02	.00	.00	.00	.0%
Depreciation	210,152.00	211,656.00	226,992.02	.00	.00	.00	.0%
40564 Golf Maintenance							
Salaries & Benefits	440,432.34	522,278.35	588,649.85	475,943.52	740,205.12	746,022.83	.8%
Supplies, Main & Srv	131,499.24	154,291.53	175,313.87	125,461.71	236,625.00	256,625.00	8.5%
Energy & Utilities	28,524.03	25,127.68	34,204.18	11,309.95	45,500.00	46,121.00	1.4%
Capital Outlay	.00	.00	.00	1,660.22	64,505.00	64,505.00	.0%
Transfers Out	105,378.00	115,160.00	122,621.00	106,260.00	127,502.00	154,431.84	21.1%
Golf Maintenance	705,833.61	816,857.56	920,788.90	720,635.40	1,214,337.12	1,267,705.67	4.4%
40571 Golf Pro Shop							
Salaries & Benefits	445,217.64	505,510.71	582,150.68	425,607.09	613,186.98	617,840.61	.8%
Supplies, Main & Srv	351,640.76	352,487.50	458,171.33	407,253.54	486,200.00	506,200.00	4.1%
Energy & Utilities	11,884.38	14,144.78	13,798.25	9,972.08	16,100.00	17,120.00	6.3%
Capital Outlay	.00	.00	.00	.00	1,000.00	1,000.00	.0%
Transfers Out	65,975.00	71,035.00	82,002.00	71,330.00	85,596.00	99,976.75	16.8%
Golf Pro Shop	874,717.78	943,177.99	1,136,122.26	914,162.71	1,202,082.98	1,242,137.36	3.3%
40575 Pension Expense GASB 68							
Salaries & Benefits	-25,848.00	-15,162.00	17,700.00	.00	.00	.00	.0%
Pension Expense GASB 6	-25,848.00	-15,162.00	17,700.00	.00	.00	.00	.0%
40900 Capital Asset-Period 13 Adj							
Capital Outlay	-195,546.00	-18,921.00	-258,299.00	553,506.00	.00	.00	.0%
Capital Asset-Period 1	-195,546.00	-18,921.00	-258,299.00	553,506.00	.00	.00	.0%
TOTAL Golf Course Fund	1,569,309.39	1,937,608.55	2,043,304.18	2,188,304.11	2,416,420.10	2,509,843.03	3.9%

NEXT YEAR BUDGET HISTORICAL COMPARISON

PROJECTION: 20276 Tentative Budget - Full Upload FOR PERIOD 13

ACCOUNTS FOR:

Transportation Fund	PRIOR FY3 ACTUALS	PRIOR FY2 ACTUALS	LAST FY1 ACTUALS	CY ACTUALS	CY REV BUDGET	PROJECTION LEVEL 4	PCT CHANGE
40481 Transportation Operations							
Salaries & Benefits	9,415,680.39	11,645,555.13	12,957,409.35	11,564,521.31	12,081,003.33	12,282,313.15	1.7%
Supplies, Main & Srv	2,013,788.87	2,942,575.86	2,048,855.04	1,215,893.47	1,696,442.28	1,631,693.72	-3.8%
Energy & Utilities	345,383.26	372,539.48	272,404.86	256,937.29	312,062.00	423,455.30	35.7%
Capital Outlay	154,773.90	307,069.54	364,372.02	422,563.02	425,934.00	425,934.00	.0%
Transfers out	3,756,742.00	3,742,831.00	3,693,665.00	3,096,530.00	3,715,829.00	3,640,351.51	-2.0%
Transportation Operati	15,686,368.42	19,010,571.01	19,336,706.27	16,556,445.09	18,231,270.61	18,403,747.68	.9%
40484 Depreciation							
Depreciation & Amort	2,737,965.00	3,391,461.00	3,269,453.77	.00	.00	.00	.0%
Depreciation	2,737,965.00	3,391,461.00	3,269,453.77	.00	.00	.00	.0%
40485 Transportation Planning							
Salaries & Benefits	539,039.93	811,375.23	897,830.85	1,157,914.97	1,711,765.38	1,735,616.94	1.4%
Supplies, Main & Srv	249,551.55	109,738.52	252,743.22	181,576.04	404,372.00	450,372.00	11.4%
Energy & Utilities	3,311.25	4,822.90	3,239.01	3,631.83	7,800.00	7,800.00	.0%
Transportation Plannin	791,902.73	925,936.65	1,153,813.08	1,343,122.84	2,123,937.38	2,193,788.94	3.3%
40575 Pension Expense GASB 68							
Salaries & Benefits	-291,282.00	-203,839.00	180,063.00	.00	.00	.00	.0%
Pension Expense GASB 6	-291,282.00	-203,839.00	180,063.00	.00	.00	.00	.0%
40900 Capital Asset-Period 13 Adj							
Capital Outlay	-7,920,774.00	-5,640,998.90	-3,976,353.00	.00	.00	.00	.0%
Capital Asset-Period 1	-7,920,774.00	-5,640,998.90	-3,976,353.00	.00	.00	.00	.0%
TOTAL Transportation Fund	11,004,180.15	17,483,130.76	19,963,683.12	17,899,567.93	20,355,207.99	20,597,536.62	1.2%

NEXT YEAR BUDGET HISTORICAL COMPARISON

PROJECTION: 20276 Tentative Budget - Full Upload FOR PERIOD 13

ACCOUNTS FOR:

Parking Fund	PRIOR FY3 ACTUALS	PRIOR FY2 ACTUALS	LAST FY1 ACTUALS	CY ACTUALS	CY REV BUDGET	PROJECTION LEVEL 4	PCT CHANGE
40484 Depreciation							
Depreciation & Amort	35,555.00	40,806.00	200,621.31	.00	.00	.00	.0%
Depreciation	35,555.00	40,806.00	200,621.31	.00	.00	.00	.0%
40500 Parking							
Salaries & Benefits	1,057,452.08	1,341,530.50	1,524,213.84	1,262,336.66	1,531,342.51	1,559,846.35	1.9%
Supplies, Main & Srv	492,733.80	664,244.92	732,070.47	380,285.63	692,800.00	796,800.00	15.0%
Energy & Utilities	17,985.05	16,268.79	8,619.76	13,601.28	11,400.00	12,613.00	10.6%
Capital Outlay	41,953.62	.00	.00	.00	.00	.00	.0%
Transfers Out	67,981.00	131,963.00	184,533.00	159,860.00	191,831.00	213,624.90	11.4%
Parking	1,678,105.55	2,154,007.21	2,449,437.07	1,816,083.57	2,427,373.51	2,582,884.25	6.4%
40575 Pension Expense GASB 68							
Salaries & Benefits	-64,714.00	-18,768.00	21,098.00	.00	.00	.00	.0%
Pension Expense GASB 6	-64,714.00	-18,768.00	21,098.00	.00	.00	.00	.0%
40900 Capital Asset-Period 13 Adj							
Capital Outlay	-107,940.00	-110,466.00	-82,359.00	.00	.00	.00	.0%
Capital Asset-Period 1	-107,940.00	-110,466.00	-82,359.00	.00	.00	.00	.0%
TOTAL Parking Fund	1,541,006.55	2,065,579.21	2,588,797.38	1,816,083.57	2,427,373.51	2,582,884.25	6.4%

NEXT YEAR BUDGET HISTORICAL COMPARISON

PROJECTION: 20276 Tentative Budget - Full Upload FOR PERIOD 13

ACCOUNTS FOR:

Fleet Services Fund	PRIOR FY3 ACTUALS	PRIOR FY2 ACTUALS	LAST FY1 ACTUALS	CY ACTUALS	CY REV BUDGET	PROJECTION LEVEL 4	PCT CHANGE
40471 Fleet Services							
Salaries & Benefits	1,214,129.81	1,330,616.32	1,458,477.42	1,200,113.76	1,675,151.76	1,698,079.61	1.4%
Supplies, Main & Srv	1,044,961.81	661,718.17	843,639.90	585,788.03	1,321,550.00	1,321,550.00	.0%
Energy & Utilities	1,110,353.61	845,042.58	796,293.72	637,065.93	1,077,900.00	1,077,900.00	.0%
Capital Outlay	4,695.08	.00	1,428.95	.00	6,205.00	6,205.00	.0%
Fleet Services	3,374,140.31	2,837,377.07	3,099,839.99	2,422,967.72	4,080,806.76	4,103,734.61	.6%
40575 Pension Expense GASB 68							
Salaries & Benefits	-15,931.00	-44,417.00	43,075.00	.00	.00	.00	.0%
Pension Expense GASB 6	-15,931.00	-44,417.00	43,075.00	.00	.00	.00	.0%
TOTAL Fleet Services Fund	3,358,209.31	2,792,960.07	3,142,914.99	2,422,967.72	4,080,806.76	4,103,734.61	.6%

NEXT YEAR BUDGET HISTORICAL COMPARISON

PROJECTION: 20276 Tentative Budget - Full Upload FOR PERIOD 13

ACCOUNTS FOR:

Self Insurance Fund	PRIOR FY3 ACTUALS	PRIOR FY2 ACTUALS	LAST FY1 ACTUALS	CY ACTUALS	CY REV BUDGET	PROJECTION LEVEL 4	PCT CHANGE
40132 Self Ins & Sec Bond							
Supplies, Main & Srv Self Ins & Sec Bond	1,746,902.84	1,352,797.35	1,847,657.25	1,409,460.17	2,087,950.00	2,137,950.00	2.4%
	1,746,902.84	1,352,797.35	1,847,657.25	1,409,460.17	2,087,950.00	2,137,950.00	2.4%
40139 Workers Compensation							
Supplies, Main & Srv workers Compensation	115,745.78	156,415.55	182,392.73	180,377.68	380,952.00	380,952.00	.0%
	115,745.78	156,415.55	182,392.73	180,377.68	380,952.00	380,952.00	.0%
40141 Dental Self Funding							
Supplies, Main & Srv Dental Self Funding	253,606.19	347,484.19	325,631.27	281,279.18	336,500.00	336,500.00	.0%
	253,606.19	347,484.19	325,631.27	281,279.18	336,500.00	336,500.00	.0%
TOTAL Self Insurance Fund	2,116,254.81	1,856,697.09	2,355,681.25	1,871,117.03	2,805,402.00	2,855,402.00	1.8%

NEXT YEAR BUDGET HISTORICAL COMPARISON

PROJECTION: 20276 Tentative Budget - Full Upload FOR PERIOD 13

ACCOUNTS FOR:

Sales Tax Rev Bond Dbt Service	PRIOR FY3 ACTUALS	PRIOR FY2 ACTUALS	LAST FY1 ACTUALS	CY ACTUALS	CY REV BUDGET	PROJECTION LEVEL 4	PCT CHANGE
40730 2017 Sales Tax Revenue Bonds							
Debt Service	2,775,885.50	2,776,384.93	2,771,734.93	305,845.75	2,775,778.00	2,775,778.00	.0%
2017 Sales Tax Revenue	2,775,885.50	2,776,384.93	2,771,734.93	305,845.75	2,775,778.00	2,775,778.00	.0%
40731 2019 Sales Tax Revenue Bonds							
Debt Service	2,419,259.00	2,962,579.46	2,413,883.46	2,050,383.00	2,408,750.00	2,408,750.00	.0%
Transfers Out	953,987.00	2,666,697.00	650,280.00	.00	.00	.00	.0%
2019 Sales Tax Revenue	3,373,246.00	5,629,276.46	3,064,163.46	2,050,383.00	2,408,750.00	2,408,750.00	.0%
40796 2014B Sales Tax Revenue Bonds							
Debt Service	773,939.50	770,189.48	770,989.47	46,683.25	774,013.00	774,013.00	.0%
2014B Sales Tax Revenue	773,939.50	770,189.48	770,989.47	46,683.25	774,013.00	774,013.00	.0%
40798 2015 Sales Tax Revenue Bonds							
Debt Service	1,002,391.00	1,001,791.13	1,002,941.13	76,103.50	1,006,075.00	1,006,075.00	.0%
2015 Sales Tax Revenue	1,002,391.00	1,001,791.13	1,002,941.13	76,103.50	1,006,075.00	1,006,075.00	.0%
TOTAL Sales Tax Rev Bond Dbt	7,925,462.00	10,177,642.00	7,609,828.99	2,479,015.50	6,964,616.00	6,964,616.00	.0%

NEXT YEAR BUDGET HISTORICAL COMPARISON

PROJECTION: 20276 Tentative Budget - Full Upload FOR PERIOD 13

ACCOUNTS FOR:

GO Bond Debt Service	PRIOR FY3 ACTUALS	PRIOR FY2 ACTUALS	LAST FY1 ACTUALS	CY ACTUALS	CY REV BUDGET	PROJECTION LEVEL 4	PCT CHANGE
40793 2013A Series GO Bonds							
Debt Service	598,453.00	599,702.68	600,290.18	27,621.75	607,038.00	607,038.00	.0%
2013A Series GO Bonds	598,453.00	599,702.68	600,290.18	27,621.75	607,038.00	607,038.00	.0%
40794 2013B Series GO Bonds							
Debt Service	.00	5,550.00	250.00	.00	.00	.00	.0%
2013B Series GO Bonds	.00	5,550.00	250.00	.00	.00	.00	.0%
40799 2017 Series GO Bonds							
Debt Service	2,202,708.00	2,187,708.04	2,175,458.04	2,152,958.00	2,156,100.00	2,156,100.00	.0%
2017 Series GO Bonds	2,202,708.00	2,187,708.04	2,175,458.04	2,152,958.00	2,156,100.00	2,156,100.00	.0%
40800 2019 Series GO Bonds							
Debt Service	4,886,092.00	4,888,491.58	4,884,341.58	4,039,092.00	4,040,900.00	4,040,900.00	.0%
2019 Series GO Bonds	4,886,092.00	4,888,491.58	4,884,341.58	4,039,092.00	4,040,900.00	4,040,900.00	.0%
40801 2020 Series GO Bonds							
Debt Service	1,800,723.50	1,795,473.12	761,723.12	95,131.67	358,338.00	358,338.00	.0%
2020 Series GO Bonds	1,800,723.50	1,795,473.12	761,723.12	95,131.67	358,338.00	358,338.00	.0%
TOTAL GO Bond Debt Service	9,487,976.50	9,476,925.42	8,422,062.92	6,314,803.42	7,162,376.00	7,162,376.00	.0%
TOTAL REVENUE	.00	.00	.00	.00	.00	.00	.0%
TOTAL EXPENSE	97,615,397.10	116,974,394.27	132,049,705.06	104,102,126.00	142,793,704.68	143,287,243.14	.3%
GRAND TOTAL	97,615,397.10	116,974,394.27	132,049,705.06	104,102,126.00	142,793,704.68	143,287,243.14	.3%

** END OF REPORT - Generated by Penny Frates **

FY27 General Fund Operating Budget Requests

SLOS - Same Level of Service Request

OTE - One Time Expense

MSS - Ongoing Materials, Services, Supplies

Department	Subcategory	Request	Manager Request	City Manager Recommendation
Public Service Contracts/Grants	PSC/Grant	Provide separate grants for non-profit arts organizations - Egyptian, Arts Council, PC Film, Summit Community Gardens	\$ 108,000	\$ 108,000
Public Service Contracts/Grants	PSC/Grant	Senior Center Executive Director Position - This increase would remove the need to apply through the competitive grant process each year and instead go through the RFP process. Will be discussed with Council on April 9th.	\$ 50,000	\$ 50,000
Historic Preservation Board Grants	PSC/Grant	Increase annual available grant amount in General Fund (see Enterprise Fund worksheet for increase to Main Street RDA). Will be discussed with Council on April 9th.	\$ 27,864	\$ -
Childcare Program	PSC/Grant	Continue Childcare Scholarship Program	\$ 685,000	\$ 685,000
PSC, Grants, Scholarship Total			\$ 870,864	\$ 843,000
City Attorneys Office	MSS	Memberships - current budget does not cover dues for State Bar licenses, Utah Attorneys Associat and other associations	\$ 3,000	\$ 3,000
City Attorneys Office	MSS	Meetings and Travel	\$ 2,000	\$ 2,000
City Attorneys Office	MSS	Software Licenses - Adobe Pro	\$ 1,600	\$ 1,600
City Attorneys Office	MSS	Outside Legal Services - inflationary and increased need for services	\$ 6,000	\$ 6,000
City Attorneys Office	MSS	Public Defender - Indigent Defense is an obligation. This request reflects increased caseload and new contract pricing.	\$ 15,000	\$ 15,000
City Attorneys Office	MSS	Legal Support Services - Current budget of \$5k does not cover contracted services with Mountain Mediation and other services like title work and analytics	\$ 15,000	\$ 15,000
CAO Total			\$ 42,600	\$ 42,600

FY27 General Fund Operating Budget Requests

SLOS - Same Level of Service Request

OTE - One Time Expense

MSS - Ongoing Materials, Services, Supplies

Department	Subcategory	Request	Manager Request	City Manager Recommendation
City Council	MSS	Memberships - need to properly budget to account for ULCTA, Central Wasatch Commission and Mountainland Association of Govt	\$ 23,000	\$ 23,000
City Council	MSS	Travel, Meetings, Conferences, Supplies, Postage	\$ 16,000	\$ 16,000
City Council Total			\$ 39,000	\$ 39,000
Communications	MSS	Web Services - portion of annual fee and chatbot feature	\$ 10,000	\$ 10,000
Economic Development/Housing	Personnel	Reclass Analyst I to Analyst II	\$ 9,613	\$ 9,613
Economic Development/Housing	Personnel	Reclass Regulatory and Property Manager	\$ 5,882	\$ 5,882
Economic Development/Housing		Savings from staff reorganization	\$ (52,185)	\$ (52,185)
Total Economic Development/Housing			\$ (36,690)	\$ (36,690)
Engineering	Vehicle	Two F150 trucks for project managers for site visits, inspections and project coordination	\$ 114,000	\$ 57,000
Human Resources	MSS	50% of PCMC Vanpool (Marsac and Public Works) - previously paid for out of COG allocation but this type of expense is no longer eligible in that program.	\$ 7,500	\$ 7,500
FY27 IFT Reallocation		Reduce charges for internal services to Enterprise Funds and increase General Fund portion	\$ 335,000	\$ 335,000
Library	Personnel	Reclass Asst Library Director position - cost includes increase in taxes and URS	\$ 12,025	\$ 12,025
Library	MSS	Book sorter annual maintenance fee - maintenance fee was covered for first two years, now it is our responsibility	\$ 13,500	\$ 13,500
Library	MSS	Security gates annual maintenance fee - maintenance fee was covered for first two years, now it is our responsibility	\$ 2,048	\$ 2,048

FY27 General Fund Operating Budget Requests

SLOS - Same Level of Service Request

OTE - One Time Expense

MSS - Ongoing Materials, Services, Supplies

Department	Subcategory	Request	Manager Request	City Manager Recommendation
Library	MSS	Book Locker (new capital project request) maintenance fee	\$ 5,162	\$ -
Library	MSS	Annual auditorium technology upgrades/maintenance	\$ 5,000	\$ 5,000
Total Library			\$ 37,735	\$ 32,573
MARC	MSS	Supplies and equipment	\$ 1,500	\$ 1,500
MARC	MSS	Software licenses	\$ 3,300	\$ 3,300
MARC	MSS	Contract services	\$ 2,500	\$ 2,500
Racquet Sports	MSS	Bubble seasonal setup/takedown	\$ 40,000	\$ 40,000
Racquet Sports	MSS	Increased price of tennis balls	\$ 4,500	\$ 4,500
Racquet Sports	MSS	Additional court cleaning due to high usage	\$ 2,000	\$ 2,000
Recreation	Personnel	Recreation Supervisor to support year-round aquatics, \$25k savings from current PT position	\$ 146,441	\$ 146,441
Recreation	Personnel	Additional lifeguards for new aquatic expansion	\$ 39,100	\$ 39,100
Recreation	Personnel	Summer Camp Counselors	\$ 21,218	\$ 21,218
Recreation	Personnel	Social Media Coord	\$ 27,508	\$ -
Recreation	Personnel	Summer Camp Asst Director	\$ 9,807	\$ -
Recreation		Reallocate PT funds to FT Supervisor position	\$ (25,000)	\$ (25,000)
Total Recreation Departments			\$ 272,874	\$ 235,559
Planning	Personnel	Reclass three Planners	\$ 25,684	\$ 25,684
Planning	MSS	Memberships	\$ 5,000	\$ 5,000
Planning	MSS	Travel/Meetings/Conferences	\$ 8,000	\$ 8,000
Planning	MSS	Software Licenses	\$ 4,000	\$ 4,000
Planning		Savings from staff reorganization	\$ (165,848)	\$ (165,848)
Total Planning			\$ (123,164)	\$ (123,164)
Public Safety		Dispatch Services Contract with Summit County - inflationary increase based on 2.8%	\$ 21,760	\$ 21,760

FY27 General Fund Operating Budget Requests

SLOS - Same Level of Service Request

OTE - One Time Expense

MSS - Ongoing Materials, Services, Supplies

Department	Subcategory	Request	Manager Request	City Manager Recommendation
Trails	Vehicle	Requested a new groomer for Bonanza Flat maintenance, alternatively, Fleet recommended a trailer for the current groomer to make transporting easier	\$ 190,000	\$ 60,000
Trails	Personnel	Reclass two PT Rangers to FT Rangers - Cost includes taxes, URS and health benefits.	\$ 217,202	\$ 217,202
Trails	Personnel	Remove 50/50 split with Transportation Planning for on FT Ranger. No longer feasible to split the duties	\$ 50,000	\$ 50,000
Expense offsets		Reallocate part-time funds and contract services funds from Trails & Sustainability	\$ (211,746)	\$ (211,746)
Total Trails and Open Space			\$ 245,456	\$ 115,456
		Total Ongoing Operating Requests	\$ 1,987,714	\$ 1,917,373
		One-time Expenses	\$ 304,000	\$ 117,000
		Savings and Reallocation of Funds	\$ (1,345,516)	\$ (1,345,516)
		Net increase for ongoing expenses	\$ 642,198	\$ 571,857

FY27 Enterprise or Other Funds Operating Budget Requests

SLOS - Same Level of Service Request

OTE - One Time Expense

MSS - Materials, Services, Supplies

Department	Subcategory	Request	Manager Request	City Manager Recommendation
Golf Shop	MSS	Range Rentals - purchase additional rental clubs and balls, offset by revenue	\$ 10,000	\$ 10,000
Golf Shop	MSS	Increased costs for maintenance and repairs, large repairs (stairs)	\$ 20,000	\$ 10,000
Golf Maint	MSS	Fertilizer, equipment repair, sand for topdressing	\$ 20,000	\$ 20,000
Golf Total			\$ 50,000	\$ 40,000
Water	MSS	Meetings/Training	\$ 5,000	\$ -
Water	MSS	Materials, Supplies and Equip	\$ 100,086	\$ 50,000
Water	MSS	Contract Services - Electrical (increased costs and maintenance needed on electrical systems)	\$ 100,000	\$ 100,000
Water	MSS	Mandated testing	\$ 5,000	\$ 5,000
Water	MSS	Miscellaneous contract services	\$ 100,000	\$ 50,000
Water	MSS	Mountain Regional water delivery contract (obligated increase)	\$ 16,503	\$ 16,503
Water	MSS	JSSD water delivery contract (obligated increase)	\$ 30,900	\$ 30,900
Water	MSS	Bank Charges	\$ 50,000	\$ 50,000
Total Water			\$ 407,489	\$ 302,403
Transportation Planning	MSS	Software Licenses	\$ 1,000	\$ 1,000
Transportation Planning	MSS	50% subsidy for 5 UTA vanpools in Summit County. Previously using 3rd qtr TST for program but likely cannot continue doing so.	\$ 45,000	\$ 45,000
Transportation Planning	Personnel	New position - Project deliver and NEPA specialist for major projects. Partial offset from savings in another position	\$ 173,707	\$ -
Transportation Planning	Personnel	New Position: Transportation Demand and Parking Planner	\$ 173,707	\$ -
Transportation Planning	Personnel	Reclass Grants Program Admin to Manager - budget neutral, offset with savings from split Trail Ranger position	\$ 17,671	\$ -
Transit Fund Total			\$ 411,085	\$ 46,000
Main Street RDA	MSS	Historic Preservation Board Grants - increase annual grant amount	\$ 45,000	\$ -

FY 27 Recommend 5 Year Capital Budget

The FY27 Tentative Five-Year Capital Budget provides an overview of planned and ongoing capital investments across all City funds, including both General Fund and Enterprise Funds. Project budgets are presented at the total project level, inclusive of all funding sources.

In the Capital Budget, carryforward represents unspent project funding from previous fiscal years that are carried into the next fiscal year. Amounts shown reflect the remaining FY26 budget after actuals through May 1; remaining FY26 activity will be incorporated into the final adopted budget.

To better understand the Capital Program, it is helpful to look beyond a simple list of active and proposed projects. Projects are grouped into four categories to provide context around their purpose, priority, and funding needs:

- **Ongoing Maintenance:** Essential, non-negotiable upkeep of existing legal and structural assets.
- **Future Maintenance:** Known or anticipated obligations resulting from prior investments, policy decisions, or established service levels.
- **In-Progress Discretionary:** Projects that have been approved and are currently in development or construction.
- **Future Discretionary:** Planned projects that have not yet broken ground or been fully committed.

In Progress – Capital Maintenance

Project	Project Title	Carry Forward	FY 27 Base	FY 27 Requested	FY 28 Base + Requested	FY 29 Base + Requested	FY 30 Base + Requested	FY 31 Requested	Total
TRA0009	Transit Rolling Stock Replacement	\$ 1,199,654		\$ 6,238,092	\$ 5,250,000		\$ 6,500,000	\$ 3,000,000	\$ 22,187,746
WAT0040	Water Dept Infrastructure Improve	\$ 2,183,098	\$ 2,000,000	\$ 1,500,000	\$ 2,500,000	\$ 3,500,000	\$ 4,000,000	\$ 4,500,000	\$ 20,183,098
TRP0025	Bus Shelters Design and Capital Imp	\$ 8,912,901		\$ 5,300,000					\$ 14,212,901
STR0074	Equipment Replacement - Rolling Sto	\$ 2,986,116	\$ 1,650,000		\$ 1,670,000	\$ 1,800,000	\$ 1,900,000	\$ 2,000,000	\$ 12,006,116
STR0006	Pavement Management Implementation	\$ 823,187	\$ 2,100,000		\$ 1,775,000	\$ 1,800,000	\$ 2,000,000	\$ 2,200,000	\$ 10,698,187
WAT0178	Rockport Water, Pipeline, and Stora	\$ 229,400	\$ 1,608,401		\$ 1,773,457	\$ 1,846,871	\$ 1,924,920	\$ 2,006,872	\$ 9,389,921
STR0146	Asset Management/Replacement Progra	\$ 1,998,078	\$ 825,000		\$ 875,000	\$ 900,000	\$ 925,000	\$ 950,000	\$ 6,473,078
WAT0389	MIW Treatment	\$ 4,648,607	\$ 281,216		\$ 292,465	\$ 304,164	\$ 316,330	\$ 328,983	\$ 6,171,765
QUI0150	Ice Facility Capital Replacement	\$ 1,165,758	\$ 1,866,000		\$ 286,000	\$ 316,000	\$ 116,000	\$ 116,000	\$ 3,865,758
WAT0256	Storm Water Improvements	\$ 1,554,268	\$ 347,288		\$ 364,652	\$ 382,884	\$ 402,029	\$ 422,139	\$ 3,473,260
TRL0092	Open Space Improvements	\$ 1,293,854	\$ 465,000		\$ 440,000	\$ 440,000	\$ 600,000	\$ 20,000	\$ 3,258,854
TEC0075	Equipment Replacement - Computer	\$ 534,580	\$ 900,000		\$ 450,000	\$ 450,000	\$ 450,000	\$ 453,000	\$ 3,237,580
TRA0316	Transit Facility Capital Renewal Ac	\$ 1,811,941	\$ 230,000		\$ 230,000	\$ 230,000	\$ 250,000	\$ 250,750	\$ 3,002,691
TRA0203	China Bridge Event Parking	\$ 1,535,699	\$ 125,000	\$ 125,000	\$ 257,500	\$ 265,225	\$ 273,182	\$ 281,377	\$ 2,862,983
REC0598	PC MARC Aquatics Replacement	\$ 2,853,819							\$ 2,853,819
WAT0304	Quinn's Water Treatment Plant Asset	\$ 1,305,154	\$ 263,114		\$ 273,638	\$ 284,584	\$ 295,967	\$ 307,806	\$ 2,730,263
WAT0341	Regional Interconnect	\$ 2,575,012							\$ 2,575,012
WAT0007	Tunnel Maintenance		\$ 332,622		\$ 345,927	\$ 359,764	\$ 374,155	\$ 389,121	\$ 1,801,589
GOL0091	Golf Maintenance Equipment Replacem	\$ 346,297	\$ 275,000		\$ 275,000	\$ 275,000	\$ 275,000	\$ 275,000	\$ 1,721,297
WAT0396	Park Ave SD	\$ 1,600,000							\$ 1,600,000
ENG0527	Homestake Roadway & Trail Imp	\$ 1,524,971							\$ 1,524,971
POL0615	Police Equipment Replacement Fund	\$ 20,447	\$ 210,775		\$ 232,775	\$ 303,270	\$ 227,000	\$ 225,250	\$ 1,219,517
ENV0266	Prospector Drain - Regulatory Proje	\$ 1,156,712							\$ 1,156,712
WAT0010	Water Department Service Equipment	\$ 352,714	\$ 146,000		\$ 152,082	\$ 158,165	\$ 164,491	\$ 171,071	\$ 1,144,523
STR0329	Main St. Infrastructure Asset Manag	\$ 766,079	\$ 100,000	\$ (25,000)	\$ 75,000	\$ 75,000	\$ 75,000	\$ 75,000	\$ 1,141,079
WAT0342	Meter Replacement	\$ 268,973	\$ 156,000		\$ 162,240	\$ 168,730	\$ 175,479	\$ 182,498	\$ 1,113,920
WAT0418	JSSD Interconnection Improvements	\$ 125,059	\$ 180,000		\$ 180,000	\$ 180,000	\$ 180,000	\$ 180,000	\$ 1,025,059
WAT0372	Regionalization Fee		\$ 200,000		\$ 200,000	\$ 200,000	\$ 200,000	\$ 200,000	\$ 1,000,000
STR0191	Walkability Maintenance	\$ 93,577	\$ 182,500		\$ 195,000	\$ 145,000	\$ 150,000	\$ 150,000	\$ 916,077
ENG0036	Traffic Calming	\$ 259,195	\$ 150,000		\$ 150,000	\$ 150,000	\$ 150,000		\$ 859,195
REC0005	City Park Improvements	\$ 306,747	\$ 100,000		\$ 100,000	\$ 100,000	\$ 100,000	\$ 100,000	\$ 806,747
TRA0601	Parking Asset Maintenance & Impro	\$ 387,970	\$ 80,000		\$ 80,000	\$ 83,200	\$ 85,000	\$ 89,000	\$ 805,170
WAT0301	Scada and Telemetry System Replacem	\$ 102,205	\$ 218,545		\$ 225,102	\$ 50,000	\$ 51,500	\$ 53,045	\$ 700,397
TEC0432	Software Subscriptions & Licenses	\$ 144,001	\$ 105,000		\$ 105,000	\$ 105,000	\$ 105,000	\$ 105,000	\$ 669,001
STR0603	Curb and Gutter Replacement	\$ 62,338	\$ 100,000		\$ 100,000	\$ 110,000	\$ 110,000	\$ 110,000	\$ 592,338
REC0729	MARC Public Restroom & Locker Room	\$ 570,000							\$ 570,000
REC0142	PC MARC Program Equipment Replaceme	\$ 238,846	\$ 65,000		\$ 65,000	\$ 65,000	\$ 65,000	\$ 65,000	\$ 563,846
WAT0397	Vehicle and Equipment Replacement	\$ 112,963	\$ 76,491		\$ 78,786	\$ 81,149	\$ 83,584	\$ 86,092	\$ 519,065
TRL0041	Trails Master Plan Implementation	\$ 164,475	\$ 50,000		\$ 50,000	\$ 50,000	\$ 100,000	\$ 100,000	\$ 514,475

In Progress – Capital Maintenance

Project	Project Title	Carry Forward	FY 27 Base	FY 27 Requested	FY 28 Base + Requested	FY 29 Base + Requested	FY 30 Base + Requested	FY 31 Requested	Total
TEC0613	Email For All	\$ 176,524	\$ 140,000	\$ (75,000)	\$ 65,000	\$ 65,000	\$ 65,000	\$ 65,000	\$ 501,524
TEC0332	Library Technology Replacement Fund			\$ 100,000	\$ 100,000	\$ 100,000	\$ 100,000	\$ 100,000	\$ 500,000
TEC0609	Future Core Software		\$ 430,000						\$ 430,000
TRA0592	CAD/AVL Replacement	\$ 354,179							\$ 354,179
STR0579	Guardrail Replacement	\$ 4,065	\$ 68,000		\$ 70,000	\$ 70,000	\$ 70,000	\$ 70,000	\$ 352,065
ENV0248	Middle Silver Creek Watershed	\$ 334,076							\$ 334,076
STR0352	Parks Irrigation System Efficiency	\$ 141,484	\$ 30,000		\$ 32,000	\$ 35,000	\$ 35,000	\$ 37,000	\$ 310,484
STR0746	Marsac Ave Plowing		\$ 60,000		\$ 60,000	\$ 60,000	\$ 60,000	\$ 60,000	\$ 300,000
REC0280	Aquatics Equipment Replacement	\$ 155,045	\$ 25,000		\$ 25,000	\$ 25,000	\$ 25,000	\$ 25,000	\$ 280,045
ART0089	Public Art	\$ 216,925		\$ 50,000					\$ 266,925
WAT0276	Water Quality Study	\$ 89,443	\$ 50,000		\$ 50,000	\$ 50,000			\$ 239,443
TRL0407	Bonanza Flats Open Space	\$ 192,112							\$ 192,112
TEC0585	Facility Wireless Upgrades	\$ 165,534							\$ 165,534
POL0264	Security Projects	\$ 120,000	\$ 40,000						\$ 160,000
REC0431	Bubble Repair	\$ 126,328		\$ 5,000	\$ 5,000	\$ 5,000	\$ 5,000	\$ 5,000	\$ 151,328
TEC0614	Virtual Conference Room	\$ 50,000	\$ 50,000		\$ 50,000				\$ 150,000
STR0340	Fleet Shop Equipment Replacement	\$ 52,598	\$ 15,000		\$ 18,000	\$ 18,000	\$ 20,000	\$ 22,000	\$ 145,598
TRA0447	EV Charges	\$ 61,799			\$ 20,000	\$ 20,600	\$ 21,218	\$ 21,855	\$ 145,472
TRA0382	Transit Security Cameras & Software	\$ 125,000							\$ 125,000
TRA0591	Transit Operations Radios Upgrade	\$ 100,762							\$ 100,762
TRL0560	Forestry Plan	\$ 99,693							\$ 99,693
TEC0422	Electrical Generator Upgrades	\$ 98,000							\$ 98,000
REC0412	PC MARC Tennis Court Resurface	\$ 79,035							\$ 79,035
STR0581	Street Sign Replacement Program	\$ 13,051	\$ 11,754		\$ 11,754	\$ 13,000	\$ 13,000	\$ 15,000	\$ 77,559
LIB0019	Library Development & Donations	\$ 73,862							\$ 73,862
REC0167	Skate Park Repairs	\$ 22,303	\$ 5,000		\$ 5,000	\$ 5,000	\$ 5,000	\$ 25,000	\$ 67,303
REC0728	MARC Gymnasium Renovation	\$ 67,222							\$ 67,222
STR0312	Fleet Management Software	\$ 63,761							\$ 63,761
LIB0617	Library Building Improvements	\$ 10,944	\$ 10,000		\$ 10,000	\$ 10,000	\$ 10,000	\$ 10,000	\$ 60,944
TRA0118	Bus Stop Sign Technology	\$ 50,000							\$ 50,000
REC0292	Cemetery Improvements	\$ 34,247							\$ 34,247
REC0607	MARC Lighting System Replacement	\$ 30,580							\$ 30,580
LIB0737	Santy Stage ADA Access	\$ 28,000							\$ 28,000
TEC0326	Website Remodel	\$ 26,925							\$ 26,925
GOL0732	Golf Cart Replacement	\$ 24,353							\$ 24,353
REC0602	PC MARC Furnishings	\$ 18,879							\$ 18,879
POL0457	City AED Replacement and Maintenan	\$ 9,567	\$ 15,000	\$ (7,000)					\$ 17,567
REC0324	Recreation Software	\$ 12,000							\$ 12,000
QUI0722	Countainer For Outdoor Ice Rink	\$ 7,500							\$ 7,500
POL0217	Emergency Management Program	\$ 6,821							\$ 6,821
TEC0332	Library Technology Equipment Replac	\$ 4,919							\$ 4,919

Future – Capital Maintenance

Project	Project Title	Carry Forward	FY 27 Base	FY 27 Requested	FY 28 Base + Requested	FY 29 Base + Requested	FY 30 Base + Requested	FY 31 Requested	Total
New15	Ice Arena Structural Remediation			\$ 50,000	\$ 900,000	\$ 600,000			\$ 1,550,000
ENG0385	Park Avenue Reconstruction	\$ 1,000,000							\$ 1,000,000
New21	Access Control & Camera Refresh			\$ 375,000	\$ 375,000				\$ 750,000
New1	MVB3X Barricade Trailers			\$ 500,000					\$ 500,000
New6	V2X Implementation			\$ 380,000					\$ 380,000
New10	Bonanza Flat Signage			\$ 325,000					\$ 325,000
New5	Wildlife Mitigation			\$ 250,000					\$ 250,000
New14	Spriggs Barn Preservation			\$ 100,000	\$ 60,000				\$ 160,000
New16	Mine Bench Erosion Control			\$ 100,000					\$ 100,000
New19	Cart Path Overlay/ReSurface			\$ 100,000					\$ 100,000
New18	Laydown Yard Beautification			\$ 9,000	\$ 9,000	\$ 9,000			\$ 27,000

Restricted – By State Law

Project	Project Title	Carry Forward	FY 27 Base	FY 27 Requested	FY 28 Base + Requested	FY 29 Base + Requested	FY 30 Base + Requested	FY 31 Requested	Total
TRL0743	McLeod Creek Trail Improvements	\$ 536,879		\$ 450,000					\$ 986,879
BUD0001	Planning/Capital Analysis	\$ 25,937							\$ 25,937
REC0364	Master Plan for Recreation Amenitie	\$ 4,889							\$ 4,889

Restricted – Council Policy

Project	Project Title	Carry Forward	FY 27 Base	FY 27 Requested	FY 28 Base + Requested	FY 29 Base + Requested	FY 30 Base + Requested	FY 31 Requested	Total
BUD0028	5 Year CIP Funding	\$ 5,073,395							\$ 5,073,395
TRP0108	Flagstaff Transit Transfer Fees	\$ 1,565,812							\$ 1,565,812
TRL0430	Treasure Hill & Armstrong	\$ 381,248							\$ 381,248
IMP0429	5-Acre Site	\$ 899							\$ 899

In Progress – Discretionary

Project	Project Title	Carry Forward	FY 27 Base	FY 27 Requested	FY 28 Base + Requested	FY 29 Base + Requested	FY 30 Base + Requested	FY 31 Requested	Total
REC0386	Recreation Building in City Park	\$ 11,747,277							\$ 11,747,277
ENG0540	Snow Creek Crossing	\$ 11,518,230							\$ 11,518,230
ENG0752	Clark Ranch Frontage Road	\$ 87,878	\$ 2,400,000	\$ 1,600,000	\$ 2,000,000				\$ 6,087,878
WAT0574	Landscaping Incentives	\$ 254,450	\$ 200,000		\$ 200,000	\$ 200,000	\$ 200,000	\$ 200,000	\$ 1,254,450
IMP0586	Housing Ongoing Asset Improvement	\$ 581,240							\$ 581,240
ENG0559	Marsac Remodel	\$ 480,670							\$ 480,670
TRP0725	Empire Transit Trailheads & Bus She	\$ 201,670							\$ 201,670
QUI0726	Lobby Upgrades - Ice Arena	\$ 105,000							\$ 105,000

Future – Discretionary

Project	Project Title	Carry Forward	FY 27 Base	FY 27 Requested	FY 28 Base + Requested	FY 29 Base + Requested	FY 30 Base + Requested	FY 31 Requested	Total
New22	5 Acre Site				\$ 35,000,000				\$ 35,000,000
TRP0411	Regional Parking Facility	\$ 9,967,865		\$ 20,032,135					\$ 30,000,000
New11	Clark Ranch			\$ 9,311,808	\$ 9,311,808				\$ 18,623,616
IMP0311	Senior Community Center	\$ 3,477,823		\$ 3,500,000	\$ 8,000,000				\$ 14,977,823
TRP0465	Recreate SR248	\$ 1,870,594		\$ 2,500,000	\$ 2,500,000	\$ 2,500,000	\$ 2,000,000		\$ 11,370,594
BUD0619	Emerging Community Development Proj	\$ 10,000,000							\$ 10,000,000
IMP0588	Housing Program Public Private Pa	\$ 7,585,593							\$ 7,585,593
New20	Golf Course Capital Improvements			\$ 250,000	\$ 3,354,500	\$ 3,354,500			\$ 6,959,000
TRP0279	SR224 Bus Rapid Transit Project		\$ 6,000,000						\$ 6,000,000
ENG0528	Munchkin & Woodbine Extn/Multi Trai	\$ 300,000		\$ 3,600,000	\$ 1,600,000				\$ 5,500,000
ENV0267	Soil Remediation	\$ 2,949,072							\$ 2,949,072
IMP0587	Housing Program Asset Acquisition	\$ 2,748,754							\$ 2,748,754
TRP0536	Bonanza District Bus Stops	\$ 2,713,009							\$ 2,713,009
TRP0381	Transit and Transportation Land Acq	\$ 2,334,654							\$ 2,334,654
BUD0361	Land Acquisition/Banking Program	\$ 249,125	\$ 2,000,000						\$ 2,249,125
TRP0478	Bike/Ped Improvements in Thayne's	\$ 556,116		\$ 1,400,000					\$ 1,956,116
TEC0339	City Wide Fiber	\$ 225,000	\$ 190,000	\$ 100,000	\$ 100,000	\$ 200,000	\$ 200,000	\$ 200,000	\$ 1,215,000
New13	Payday Traffic Calming and Iron Canyon Sidewalk			\$ 150,000	\$ 1,000,000				\$ 1,150,000
IMP0401	Main Street Area Plan	\$ 839,902							\$ 839,902
TRP0439	Bonanza Multi-Modal and Street Impr	\$ 620,000							\$ 620,000
TRP0469	Deer Valley Drive Bike & Ped	\$ 550,000							\$ 550,000
TRP0441	Transportation Demand Management Pr	\$ 440,372							\$ 440,372
New4	Multimodal Wayfinding			\$ 315,000					\$ 315,000
TRP0608	SR224 Roundabout Transit Priority D	\$ 300,000							\$ 300,000
TRP0313	Transportation Grants/Plans/Policy	\$ 246,289							\$ 246,289
New9	Wayfinding & TDM Technology			\$ 100,000	\$ 100,000				\$ 200,000
ENG0730	Kearns Blvd Multipurpose Trail	\$ 150,000							\$ 150,000
New8	Old Town Pedestrian Connections			\$ 120,000					\$ 120,000
TRA0751	Richardson Flat Restrooms	\$ 80,000		\$ 20,000					\$ 100,000
TRL0721	PC Heights Area Trails	\$ 93,057							\$ 93,057
TRP0453	Old Town Access and Circulation Pla	\$ 90,000							\$ 90,000
GOL0046	Golf Course Improvements		\$ 12,000		\$ 12,000	\$ 12,000	\$ 12,000	\$ 12,000	\$ 60,000
ENV0612	Trees for City Lands	\$ 15,000							\$ 15,000
TRL0744	Quinn's Double Track Improvements	\$ 5,510							\$ 5,510

City Council Staff Report



Subject: IT Assessment Findings
Author: Scott W. Robertson | Michelle Downard
Department: Information Technology | Exec
Date: May 7, 2026

Recommendation

Review and discuss BerryDunn's findings outlined within the IT Assessment. BerryDunn will provide context for the assessment, summarize key findings, and outline immediate steps for implementing short-term governance and project prioritization recommendations.

Executive Summary

City leadership initiated an independent review of Information Technology (IT) operations to ensure our infrastructure keeps pace with the increasing complexity of municipal operations. Following a competitive RFP process, BerryDunn was selected to conduct a comprehensive assessment. Their findings confirmed that while IT is service-oriented, it currently operates reactively. Informal governance and a lack of shared prioritization have created significant sustainability risks and operational inefficiencies.

In response, the City has launched a "Governance Pilot" to implement BerryDunn's high-priority recommendations. This includes reestablishing a Technical Governance Committee and a structured project intake framework. These initiatives will ensure IT resources are aligned with City priorities, improve transparency, and protect staff capacity through data-driven decision-making.

BerryDunn will present summarized findings to City Council in conjunction with this report.

Analysis

The IT assessment conducted by BerryDunn included stakeholder engagement, staff interviews, and benchmarking against peer municipalities. The results confirmed that while IT continues to deliver a high level of service, the current model is largely reactive and lacks the governance structures necessary to support strategic decision-making. In particular, the absence of a shared prioritization model makes it difficult to align IT work with broader City priorities and effectively manage increasing demand.

The assessment highlights that IT is managing a significant and growing volume of project requests originating across departments. Historically, these requests have been addressed in a decentralized manner, limiting visibility. As a result, the organization lacks a consistent mechanism to evaluate trade-offs when demand exceeds available capacity. For instance, a department may purchase a specialized software solution assuming it is a "plug-and-play" installation. However, this often triggers a cascade of unbudgeted IT work, including data security reviews, server integration, and ongoing

maintenance. Without a centralized intake process, these "hidden" project requirements compete for the same staff time as City-wide priorities, often without leadership's awareness.

In response, BerryDunn identified 15 focus areas across short, medium, and long-term horizons. IT has begun executing Phase 1 which includes:

- Reestablishing the Technology Governance Committee: To provide cross-departmental oversight.
- Structured Project Intake: Moving away from "first-come, first-served" toward a value-based methodology.
- Standardizing Categorization: Distinguishing between "Compliance" (e.g., mandated security patches or audit requirements) and "Departmental Enhancements" (e.g., a new digital permit portal).

Initial efforts are focused on improving transparency through a SharePoint-based project dashboard. This tool provides greater visibility into project status, and critically, the "level of effort" required for each task. Because the City currently lacks standardized data on project duration, implementation is being approached in a phased manner. We are piloting these scoring metrics on a manageable subset of projects to support near-term decision-making while building toward a more mature, data-driven governance model.

As this work progresses, IT will utilize existing resources to refine capacity estimates and expand participation in the governance process. These efforts are intended to move IT from a reactive support role to a predictable, strategic partner, ensuring that our limited technical resources are always directed toward the City's highest-priority goals.

Funding

The IT Department is currently evaluating its internal structure to ensure existing resources are aligned with the BerryDunn recommendations. Rather than requesting new funding at this time, the department is focused on redefining two vacant FTE positions. These are replacement roles, but they are being updated to address specific gaps in project management and departmental support identified in the assessment. This allows the City to implement immediate improvements within the current budget.

However, the assessment does identify long-term staffing and infrastructure needs that will likely require additional investment in future budget cycles. The department will use the upcoming 12 to 18 months to gather data through the new governance framework to justify any future requests. Additionally, current workspace and seating are at capacity, which remains a constraint for any future staffing increases. By focusing on process improvements and functional realignment now, the department will be better prepared to present data-driven requests in the future.

Exhibits

- BerryDunn Presentation Slides



Park City Municipal Corporation

IT Assessment



May 7, 2026

Agenda

- ▲ **1** Introductions and Project Overview
- ▲ **2** Current State Assessment and Benchmarking Report Key Themes
- ▲ **3** Recommendations and Roadmap Focus Areas
- ▲ **4** Questions



BerryDunn Team



Erin Provazek

Engagement Manager

MBA, PMP®, COBIT, Prosci®
CCP, CGCIO, ITIL (F)

Senior Manager | Berry, Dunn,
McNeil & Parker, LLC



Jeff Martin

Project Manager

PMP®, CGCIO, CBCP,
CCRP

Senior Consultant | Berry,
Dunn, McNeil & Parker, LLC



Project Overview

Assessment Scope



IT Service Delivery

- IT Project Management
- IT Change Management
- IT Incident and Request Management
- IT Asset Management
- Technology Procurement



IT Staffing

- Organizational Structure
- Staffing Levels
- Roles and Responsibilities
- Professional Development
- Contractors vs. Full-Time Employees



Project Overview

Discovery Activities and Implementation Roadmap



Current State Assessment and Benchmarking Report

Key Challenges and Opportunities for Improvement



IT is service oriented and operating reactively.



Governance and coordination processes are missing or inconsistently applied.



Informal and decentralized approaches are becoming unsustainable.



IT staff are delivering a high volume of support, which creates sustainability and burnout risk over time.



Absence of shared prioritization creates frustration for IT and departments.



IT carries the highest support workload among peer agencies limiting availability for training and professional development.



Recommendation Implementation Timeline

Time frames to begin recommendation implementation:

Recommendation Type	Number of Recommendations	Initiation Time Frame
Short-Term Recommendations	8	Within 18 months
Medium-Term Recommendations	4	Within 24 months
Long-Term Recommendations	3	Within 36 months



Recommendations and Implementation Roadmap

Recommendation Focus Areas

Short-Term (Within 18 Months): Establish the Foundation

- Establish clear roles and accountability for technology-related decisions.
- Improve how technology issues and requests are handled so staff experience fewer disruptions.
- Improve how staff are informed when technology changes affect their work.
- Address workload pressure and reliance on a small number of individuals through staff augmentation.

Medium-Term (Within 24 Months): Improve Planning and Coordination

- Improve visibility into future technology needs and associated costs through lifecycle planning.
- Strengthen coordination between departments and technology staff.
- Improve how technology changes are reviewed and assessed.
- Adjust roles and responsibilities within IT to better support business applications and departments.

Long-Term (Within 36 Months): Create Sustainability and Improve Service Delivery

- Make it easier for staff to find guidance, request services, and resolve common issues.
- Shift focus from fixing the same problems repeatedly to addressing root causes.
- Formalize cross-training and succession planning.
- Create space for professional development and knowledge sharing.



IT Department's Current Implementation Activities

IT Project Management Framework



- IT has developed a standard for categorizing, prioritizing, and managing technology projects.
- IT has developed a SharePoint page with information on project prioritization and governance.

Improved Communications and Transparency



- IT has developed SharePoint pages to improve communications around technology changes, project management, and prioritization.

Technology Governance Committee



- Reestablishing the Technology Governance Committee to improve coordination between IT and departments.



Questions

Resolution No. 07-2026

**A RESOLUTION PROCLAIMING MAY 2026
HISTORIC PRESERVATION MONTH IN PARK CITY**

WHEREAS, Park City was established as a mining camp after the discovery of silver at the Flagstaff Mine in 1868 and ore at the Ontario Claim in 1872;

WHEREAS, many historic resources celebrate and honor Park City's Settlement & Mining Boom Era (1868-1893), Mature Mining Era (1894-1930), and Mining Decline & Emergence of Recreation Industry (1931-1962);

WHEREAS, Park City has two National Historic Districts – the Main Street Historic District listed in 1979 and the Mining Boom Era Residences Thematic District listed in 1984;

WHEREAS, in 2023, Park City's Historic Mining Resources were included as a Multiple Property Listing on the National Register of Historic Places;

WHEREAS, more than 400 sites are designated Landmark or Significant Historic Sites on Park City's Historic Sites Inventory;

WHEREAS, 12 mining sites are designated Landmark or Significant Historic Sites on Park City's Historic Sites Inventory;

WHEREAS, historic preservation is an economic driver for Park City's Old Town and Historic Main Street is the heart of our community;

WHEREAS, Historic Character is one of the core values in the Park City General Plan;

WHEREAS, the seven-member Historic Preservation Board of Park City preserves the City's unique historic character, recommends ordinances to encourage historic preservation, communicates the benefits of historic preservation for the education, prosperity, and general welfare of residents, visitors, and tourists, and administers the Historic District Grant Program;

WHEREAS, the Park City Museum and Friends of Ski Mountain Mining History and other local groups and property owners preserve and prioritize Park City's history and the rehabilitation of the City's Historic Structures;

WHEREAS, the Utah State Historic Preservation Office recognizes May as Archaeology and Historic Preservation Month;

NOW, THEREFORE BE IT RESOLVED, that the Park City Council declares the month of May 2026 to be "Historic Preservation Month" in Park City.

SECTION 1. EFFECTIVE DATE. This Resolution shall take effect upon adoption.

PASSED AND ADOPTED this 7th day of May, 2026.

PARK CITY MUNICIPAL CORPORATION

Mayor Ryan Dickey

ATTEST:

Michelle Kellogg, City Recorder

APPROVED TO FORM:

City Attorney's Office



City Council Staff Report

Subject: Proposed Changes to Section 2-3-11 Disposal of Significant Parcels

Author: Ryan Blair

Department: Economic Development and Housing

Date: May 7, 2026

Recommendation

Review and consider approving Ordinance 2026-08 updating Park City Code Section 2-3-11 Review of Disposals of Significant Parcels of Real Property. In the 2026 Utah Legislative Session, [HB535](#) was enacted, which added requirements and extended the notification period for significant property dispositions.

Executive Summary

[HB535](#) modified several sections of Utah Code, including, most relevant to the City, section 10-8-2, and created section 11-1-201. Notable changes include lengthening public notification periods, posting physical signs at significant parcels notifying the public of a potential sale, and defining fair market value as \$500,000 or more. HB535 went into effect May 6, 2026.

The proposed updates to City Code reflect an alignment with the language in [HB535](#), keeping an important clarifying section about leases, and removing exceptions for affordable housing as they are not an exception permitted under State Code. Rather than update the City's Code language each time the State modifies its code, we recommend making a few adjustments to the City's ordinance and referencing State Code for additional requirements.

Exhibits

- A *Draft Ordinance 2026-08 Code Amendment 2-3-11 Review of Significant Parcels of Real Property*
- B *Proposed Code Changes*

Ordinance No. 2026-08

AN ORDINANCE AMENDING SECTION 2-3-11 REVIEW OF DISPOSALS OF SIGNIFICANT PARCELS OF REAL PROPERTY

WHEREAS, the City desires to align its Code with Utah State Code Sections 10-8-2 and 11-1-201 to -205, as those sections were amended by House Bill 535 of the 2026 General Session of the Utah Legislature.

WHEREAS, the amendments clarify the requirements for notification and disposal of significant property.

WHEREAS, lengthening the public notification period leads to a more informed public before disposing of significant property.

BE IT ORDAINED BY THE CITY COUNCIL OF PARK CITY, UTAH, THAT:

Section 2-3-11 of the Park City Code is amended and adopted to read as outlined in Exhibit B. This Ordinance shall become effective upon publication.

PASSED AND ADOPTED this 7th day of May 2026.

PARK CITY MUNICIPAL CORPORATION

Mayor Ryan Dickey

Attest:

Michelle Kellogg, City Recorder

Approved as to form:

City Attorney's Office

2-3-11 Review ~~o~~f Disposals ~~o~~f Significant Parcels ~~o~~f Real Property

~~A.~~—The City Council shall review all proposed ~~edals for~~ dispositions of significant parcels of real property. Prior to the proposed disposition, the City shall comply with the notice and publication requirements in the Utah Code. ~~Council shall provide at least fourteen (14) days reasonable notice before the opportunity for public comment on the proposed disposition.~~ After such ~~reasonable~~ notice, publication and public comment, the City Council may take action on the proposed disposition.

1. ~~—~~“Dispose of” shall mean to transfer control of City-owned property to another by any means, including sale, lease, or other type of conveyance of such property:

2. ~~—~~“Reasonable notice” shall mean posting on or about the property in a conspicuous location and publication in a newspaper having general circulation in Park City.

A. B.

B. —“Significant parcel of real property” shall mean a parcel of real property owned by the City with an appraised value equal to or greater than ~~Two Hundred Fifty Thousand Dollars (\$50250,000)~~ or a lease valued at equal to or greater than ~~Fifty Thousand Dollars (\$50,000)~~ per yearannum.

3. ~~—~~Affordable or Attainable Housing Parcels subject to the City's Affordable Housing Resolution and/or deed restrictions, including all units and properties included in or funded by the City's Affordable Housing Budget, are not Significant Parcels subject to this section, regardless of value or sales price.

4. ~~—~~Temporary Special Event or Master Festival leases of public property are not Significant Parcels subject to this section, regardless of lease value.



City Council Staff Report

Subject: Acceptance of Public Improvements for the Moonshadow Condominiums Development
Author: Becky Gutknecht, P.E., Assistant City Engineer
Department: Engineering
Date: May 7, 2026

Recommendation

Consider a request to approve Ordinance No. 2026-09 accepting the public improvements that were installed as part of the Moonshadow Condominiums Development.

Executive Summary

Storied Deer Valley, LLC has completed the required public improvements associated with the development of the Moonshadow Condominiums, and the warranty period has now expired. At this time, the Engineering Department recommends that the City Council approve an ordinance accepting the public improvements associated with the Moonshadow Condominiums Development.

Background

The Moonshadow Condominiums Development installed certain public improvements with the construction of the development. The public improvements proposed for acceptance by Council include infrastructure related to the City's drinking water system. This infrastructure was installed in accordance with the Park City Supplemental Standard Plans and Specifications. Third-party inspections were provided throughout construction through contract services managed by the City Engineer's Office. Per the construction agreement for public improvements, the developer provided a one-year warranty period following verification of final completion. The warranty period for the completed improvements is now expired.

Other infrastructure installed with this development, including streets and storm water infrastructure, is being retained privately. As such, no right-of-way is being dedicated in conjunction with this acceptance.

- [September 26, 2018](#) - Planning Commission forwarded a positive recommendation for the Moonshadow Condominiums Plat to City Council.
- [October 23, 2018](#) - City Council approved [Ordinance No. 2018-54](#) approving the subdivision plat.
- November 28, 2023 – Public improvements were inspected, which led to the creation of a punch list of the remaining items that needed to be resolved prior to closing the warranty period.

- November 5, 2025 – A final inspection verified and confirmed the completion of all required punch list items. The warranty period was officially closed and the remaining Improvement Completion Assurance was released.

The Land Management Code addresses acceptance of public improvements in Chapter 15-7.2 Assurance For Completion And Maintenance Of Improvements.

- The City Engineer has verified that all required improvements have been satisfactorily completed;
- Complete as-built drawings “indicating location, dimensions, materials, and other information required by the Planning Commission and City Engineer have been received by the Engineering Department and are certified by the Applicant’s engineer that the layout of the line and Grade of all public improvements is in accordance with the City approved construction plans for the Subdivision”; and
- Acceptable evidence has been furnished to the City indicating that the improvements have been completed and are ready for dedication to the local government and are free and clear of any and all liens and encumbrance has been received.

Inspections by the Engineering Department and the Public Utilities Department have verified that all public improvements associated with the Moonshadow Condominiums Development have been completed satisfactorily and are ready for acceptance.

Exhibits

A Moonshadow Condominiums – Acceptance of Public Improvements - Draft Ordinance Number 2026-09

When recorded please return to:
Park City Municipal Corporation
Attn: City Engineer
PO Box 1480
Park City UT 84060

ORDINANCE NO. 2026-09

AN ORDINANCE ACCEPTING THE PUBLIC IMPROVEMENTS FOR THE MOONSHADOW CONDOMINIUMS DEVELOPMENT PROJECT

WHEREAS, Moonshadow Condominiums Development consists of 8 lots in the south half of Section 21, Township 2 South, Range 4 East, Salt Lake Base and Meridian;

WHEREAS, Construction of the public improvements for the Moonshadow Condominiums has been completed by the developer. The public improvements include water distribution and service lines, and other related water infrastructure;

WHEREAS, Park City has adopted Land Management Code Section 15-7.2-3, which provides for the City Council to accept (by Ordinance) those public improvements which are dedicated and built in accordance with the requirements of the Park City Code and the Park City Supplemental Standard Plans and Specifications;

WHEREAS, Developer has certified to the City Engineer, through submission of detailed "as-built" survey drawings of the Subdivision, indicating location, dimensions, materials, and other information required by the City Engineer, that the layout of the line and grade of all public improvements is in accordance with the City approved construction plans for the development;

WHEREAS, verification has been supplied by the developer showing that there are no liens against the project;

WHEREAS, the public improvements within the development described above were installed in accordance with Park City Design Standards Construction Specifications and Standard Drawings and have been duly inspected by the City Engineer; and

WHEREAS, the required punch list items were completed on November 5, 2025, and the one-year warranty period has expired.

NOW, THEREFORE BE IT ORDAINED by the City Council of Park City, Utah as follows:

SECTION 1. PUBLIC IMPROVEMENTS. The City hereby accepts from the developer all public improvements at and related to the Moonshadow Condominiums development described above.

SECTION 2. EFFECTIVE DATE. This Ordinance shall take effect upon publication.

PASSED AND ADOPTED this 7th day of May, 2026.

PARK CITY MUNICIPAL CORPORATION

Ryan Dickey, MAYOR

ATTEST:

Michelle Kellogg, CITY RECORDER

APPROVED AS TO FORM:

City Attorney's Office



City Council Staff Report

Subject: Acceptance of Public Improvements for the Huntsman Estates Development
Author: Becky Gutknecht, P.E., Assistant City Engineer
Department: Engineering
Date: May 7, 2026

Recommendation

Consider a request to approve Ordinance No. 2026-10 accepting the public improvements that were installed as part of the Huntsman Estates Development.

Executive Summary

DV Lodge, LLC has completed the required public improvements associated with the development of the Huntsman Estates subdivision, and the warranty period has expired. At this time, the Engineering Department recommends that the City Council approve an ordinance accepting the public improvements associated with the Huntsman Estates Development.

Background

The Huntsman Estates Development installed certain public improvements with the construction of the development. The public improvements, proposed to be accepted by Council, include the infrastructure related to the drinking water system. This infrastructure was installed in accordance with the Park City Supplemental Standard Plans and Specifications. Third-party inspections were provided throughout construction through contract services managed by the City Engineer's Office. Per the construction agreement for public improvements, the developer provided a one-year warranty period after issuance of final completion. The warranty period for the completed improvements has now expired.

Other infrastructure installed with this development, including streets and storm water infrastructure, is being retained privately. As such, no right-of-way is being dedicated in conjunction with this acceptance.

- [May 27, 2020](#) - Planning Commission forwarded a positive recommendation for the Huntsman Estates Subdivision Plat to City Council.
- [July 9, 2020](#) - City Council approved [Ordinance No. 2020-31](#) approving the subdivision plat.
- September 6, 2023 – Public improvements were inspected, which led to the creation of a punch list of items that needed to be resolved prior to the warranty period closing.

- April 8, 2026 – A final inspection verified and confirmed the completion of all required punch list items. The warranty period was officially closed, and the remaining Improvement Completion Assurance was released.

The Land Management Code addresses acceptance of public improvements in chapter 15-7.2 Assurance For Completion And Maintenance Of Improvements.

- The City Engineer has verified that all required improvements have been satisfactorily completed;
- Complete as-built drawings “indicating location, dimensions, materials, and other information required by the Planning Commission and City Engineer have been received by the Engineering Department and are certified by the Applicant’s engineer that the layout of the line and Grade of all public improvements is in accordance with the City approved construction plans for the Subdivision”; and
- Acceptable evidence has been furnished to the City indicating that the improvements have been completed and are ready for dedication to the local government and are free and clear of any and all liens and encumbrance has been received.

Inspections by the Engineering Department and the Public Utilities Department have verified that all public improvements associated with the Huntsman Estates Development have been completed satisfactorily and are ready for acceptance.

Exhibits

A Draft Ordinance Number 2026-10

When recorded please return to:
Park City Municipal Corporation
Attn: City Engineer
PO Box 1480
Park City UT 84060

ORDINANCE NO. 2026-10

AN ORDINANCE ACCEPTING THE PUBLIC IMPROVEMENTS FOR THE HUNTSMAN ESTATES DEVELOPMENT PROJECT

WHEREAS, Huntsman Estates consists of 15 lots in the east half of Section 21 and the west half of Section 22, Township 2 South, Range 4 East, Salt Lake Base and Meridian;

WHEREAS, Construction of the public improvements for Huntsman Estates has been completed by the developer. The public improvements include water distribution and service lines, and other related water infrastructure;

WHEREAS, Park City has adopted Land Management Code Section 15-7.2-3, which provides for the City Council to accept (by Ordinance) those public improvements which are dedicated and built in accordance with the requirements of the Park City Code and the Park City Supplemental Standard Plans and Specifications;

WHEREAS, Developer has certified to the City Engineer, through submission of detailed "as-built" survey drawings of the Subdivision, indicating location, dimensions, materials, and other information required by the City Engineer, that the layout of the line and grade of all public improvements is in accordance with the City approved construction plans for the development;

WHEREAS, verification has been supplied by the developer showing that there are no liens against the project;

WHEREAS, the public improvements within the development described above were installed in accordance with Park City Design Standards Construction Specifications and Standard Drawings and have been duly inspected by the City Engineer; and

WHEREAS, the required punch list items were completed on April 8, 2026, and the one-year warranty period has expired.

NOW, THEREFORE BE IT ORDAINED by the City Council of Park City, Utah as follows:

SECTION 1. PUBLIC IMPROVEMENTS. The City hereby accepts from the developer all public improvements at and related to the Huntsman Estates development described above.

SECTION 2. EFFECTIVE DATE. This Ordinance shall take effect upon publication.

PASSED AND ADOPTED this 7th day of May, 2026.

PARK CITY MUNICIPAL CORPORATION

Ryan Dickey, MAYOR

ATTEST:

Michelle Kellogg, CITY RECORDER

APPROVED AS TO FORM:

City Attorney's Office



City Council Staff Report

Subject: APWA and 2026 Update to the Park City Supplemental Standard Plans and Specifications
Authors: William Popp, John Robertson, P.E., City Engineer
Department: Engineering
Date: March 9, 2026

Recommendation

Consider approving Ordinance 2026-11 adopting the most current version of the American Public Works Association (APWA) Utah Chapter standard plans and specifications, and the Park City 2026 Supplemental Standard Plans and Specifications (2026 Supplemental Standards). These will serve as the standards and guidelines for the design and construction of projects, including private development, within existing and future public rights-of-way.

Background

The City Engineer's office maintains a set of specifications and plans that establish standards, general guidelines, and requirements for the design and construction of infrastructure, including private development work, within existing and future rights-of-way. These specifications and plans aim to set quality and consistency standards in materials and construction methods. Combined with inspections, they increase the longevity and functionality of public improvements and help to reduce long-term maintenance costs. In addition, standard specifications provide contractual language to guide the behavior and relationship between contractors and the City during construction activities.

The APWA standards were created to provide uniform construction practices throughout Utah and standard requirements for supplying and installing materials and systems, and to present industry consensus on uniform organization and sequencing of specifications. These are commonly adopted across Utah and enable Park City to establish consistency of construction materials and practices. However, due to Park City's unique location, challenges, and characteristics, supplementing the APWA standards with the Park City Supplemental Standard Plans and Specifications is necessary. The Park City Supplemental Standard Plans and Specifications were created to address these unique conditions and compile City-specific standards (such as water and street standards) into one document on the City's website for consistency and easy reference. In 2021, it had been nearly a decade since the previous Park City Supplemental Standard Plans and Specifications had been revised. The Engineering Department, in cooperation with other City Departments, made a significant revision to bring them up to date with current codes and requirements. To ensure the Park City Supplemental Standard Plans and Specifications continue to align with current codes and any new changes that come up within the City or construction material availability or technologies, the Engineering Department makes yearly, minor updates.

City Council adopted the most recent revision, the 2025 Park City Supplemental Standard Plans and Specifications, as well as the APWA Utah Chapter standard plans and specifications, on June 12, 2025.

Since the last update in 2025, the APWA Utah Chapter adopted the 2026 APWA Utah Manual of Standard Plans and Specifications. We have updated the current 2026 Supplemental Standards to incorporate revisions made to the 2026 APWA Standards. Over the past year, we have also made additional minor changes, including:

- Revising some material specifications, such as untreated base course, to account for the availability of materials locally;
- Adding estimated unit prices for common construction items to help create accurate construction inspection fees and improvement completion guarantees; and
- Adding more detailed information regarding crosswalk installation and guidelines.

To address inconsistencies across the City regarding crosswalks, we developed the Park City Crosswalk Treatment Guidelines, which are referenced in the newest 2026 Supplemental Standards to ensure consistent application and installation throughout the City.

The Land Use, Development, and Management Act, found in Title 10, Chapter 20, of the Utah Code (commonly referred to as LUDMA), authorizes and governs cities' land use and zoning regulations. Because the APWA and the 2026 Supplemental Standards detail and define various aspects of development, they fall under LUDMA's requirements. Thus, for formal adoption of the APWA and the 2026 Supplemental Standards, the regulations of Utah Code Title 10, Chapter 20 must be followed, including giving proper written notice, holding a public hearing, receiving a positive recommendation from the Planning Commission, and eventual adoption by the City Council.

In accordance with this requirement, on April 8, 2026, the Planning Commission reviewed a recommendation to forward to the City Council a proposal to adopt the APWA and 2026 Park City Supplemental Standards. They voted to forward a favorable recommendation to City Council for their adoption.

Attachments

- A 2026 Park City Supplemental Standard Plans & Specifications
- B Ordinance to Adopt PCMC Supplemental Standard Plans & Specifications and APWA Manuals of Standard Drawings and Specifications



2026
Supplemental Standard Plans &
Specifications

ADOPTED BY PARK CITY COUNCIL XXXX XX, 2026

TABLE OF CONTENTS

DIVISION 100 ADMINISTRATIVE & GENERAL REQUIREMENTS

100.01	Introduction to Park City Engineering Standards
100.02	Standards for Construction
100.03	General Improvement Requirements & Design Guidelines

DIVISION 200 STREETS

200.01	Roadway Standards
200.02	Standard Roadway Drawings
205.4	Curb Type G
205.5	Street Structural Details
208	Typical Street Section For Utilities
210	Typical Intersection Locations of Utilities
217	Heated Pavement
230	Main Street Sidewalk Details
	1-A: Granite Stone Paver Section & Truncated Dome Brick Paving
	1-B: Concrete Paving Control Joints & Concrete band Between Granite Paver Sections
	1-C: Concrete Band at Granite Curb Section
	1-D: Granite Curb Section
	1-E: Granite Curb at Driveway & Transition at Building
	1-F: Vehicular Concrete Paving & Vehicular Brick Paving
	2-A: Concrete/Granite Stone Pavers at Water Meter Section & Street Light Base
	2-B: Sidewalk Section Typical
	2-C: Sidewalk Paving Pattern – Enlargement Plan
	3-A: Pedestrian Truncated Dome Brick Paving & Vehicular Truncated Dome Brick Paving
	3-B: Pedestrian Brick Paving & Concrete Curb Wall at Stairs
	3-C: Granite Curb at Crosswalk
	3-D: Granite Curb at Driveway
	3-E: Removable Bollard
231	Sidewalk Details
293.1	Street Sign Details
293.2	Street Sign Details
294	Mounting Detail for Sign on Light Pole
295	Standard City Street Monument
296.01	Street Lighting Product Specifications
296.1	Street Lighting
296.2	Street Light Base Details

DIVISION 300 STORM DRAIN

300.02	Standard Storm System Drawings
315.1	Single Grade Catch Basin
315.2	Double Grade Catch Basin
382	Pipe Zone Backfill
399	Private Connection to Public Storm System

DIVISION 400 NOT USED

DIVISION 500 WATER SYSTEMS

Notes, Abbreviations, and Symbols

500.1	General Water Notes
500.2	General Water Notes
500.3	General Water Notes

Fire Hydrants

511	Fire Hydrant
511 S	Fire Hydrant

Water Meters

520.1	General Requirements – Water Meter, Meter Vault, and Service Line
520.2	General Requirements – Water Meter, Meter Vault, and Service Line
521	3/4" and 1" Single Meter – Outside Setting
521 S	3/4" and 1" Single Meter – Outside Setting
522	3/4" and 1" Dual Meters – Outside Setting
522 S	3/4" and 1" Dual Meters – Outside Setting
523	3/4" and 1" Meter – Inside Setting
523 S.1	3/4" and 1" Meter – Inside Setting
523 S.2	3/4" and 1" Meter – Inside Setting
524	1 1/2" and 2" Single Meter – Outside Setting
524 S	1 1/2" and 2" Single Meter – Outside Setting
525	1 1/2" Dual Meters – Outside Setting
525 S	1 1/2" Dual Meters – Outside Setting
526	1 1/2" and 2" Meter – Inside Setting
526 S.1	1 1/2" and 2" Meter – Inside Setting
526 S.2	1 1/2" and 2" Meter – Inside Setting
527	3" and Larger Meter – Outside Setting
527 S	3" and Larger Meter – Outside Setting
528	3" and Larger Meter – Inside Setting
528 S.1	3" and Larger Meter – Inside Setting
528 S.2	3" and Larger Meter – Inside Setting
529	Meter Vault Frame and Cover / MXU Device Location
529 S	Meter Vault Frame and Cover / MXU Device Location

- 530 Remote MXU Device
- 531 Temporary Hydrant Meter Assembly

Corrosion Protection Systems

- 534.1 Metallic Pipe Corrosion Protection
- 534.2 Metallic Pipe Corrosion Protection
- 535-A Type A Test Station
- 535-B Type I Test Station
- 535-C Type F Test Station
- 535-D Type T Test Station
- 536-A Horizontal Galvanic Anode Installation without Test Station
- 536-B Horizontal Galvanic Anode Installation
- 537-A Steel and Ductile Iron Pipe Wire Connection
- 537-B Ductile Iron Pipe Joint Bond
- 537-C Flexible Joint Bond
- 537-D Flanged and Mechanical Joint Bond
- 537-E Galvanic Anode Wire Splice
- 537-F Insulating Flange
- 537-G.1 Metallic Pipe Appurtenance and Fitting Cathodic Protection
- 537-G.2 Metallic Pipe Appurtenance and Fitting Cathodic Protection
- 537-G.3 Metallic Pipe Appurtenance and Fitting Cathodic Protection
- 537-G.4 Metallic Pipe Appurtenance and Fitting Cathodic Protection
- 538-A Post Style Test Station – Wood
- 538-B Post Style Test Station – Plastic
- 538-C Flush Style Test Station Box
- 538-D Flush Style Test Station Terminal Board

Piping

- 540-A Water Main – Ductile Iron Pipe – 4” to 12” Diameter
- 540-B Water Main – PVC Pipe – 4” to 12” Diameter
- 540-C Water Main – HDPE Pipe – 4” to 16” Diameter
- 540-D Connections to Existing Water Main– Asbestos Cement & Permastrand Pipe – 4” to 12” Diameter
- 540 S.1 Water Main and Fire Lines
- 540 S.2 Water Main and Fire Lines
- 541 Water Service Line – 3/4” to 2” Meters
- 541 S Water Service Line – 3/4” to 2” Meters
- 542 Hot Taps – 4” and Larger
- 543 Water Service Line Loop
- 544-A Water Main Loop
- 544-B Water Main Loop
- 544-C Water Main Loop
- 545-A Tracer Wire – Valve Box Termination
- 545-B Tracer Wire – Access Box Termination
- 546 Pipe Insulation at Storm Drain Crossings
- 547-A Water - Sanitary Sewer Separation
- 547-B Water - Sanitary Sewer Separation

548 3/4" to 2" Service Line Abandonment

Thrust Blocks

561 Direct Bearing Thrust Block
562-A Tie-down Thrust Restraints
562-B Tie-down Thrust Restraints

Valves

570 Buried Valve and Valve Box
570 S Buried Valve and Valve Box
571 Valve Box Collar
573-A Pressure Reducing Valve Vault
573-B.1 Pressure Reducing Valve Vault
573-B.2 Pressure Reducing Valve Vault
573-C.1 Pressure Reducing Valve Vault
573-C.2 Pressure Reducing Valve Vault
573-C.3 Pressure Reducing Valve Vault
573-C.4 Pressure Reducing Valve Vault
573-D.1 Pressure Reducing Valve Vault
573-D.2 Pressure Reducing Valve Vault
573-D.3 Pressure Reducing Valve Vault
573-D.4 Pressure Reducing Valve Vault
573-E.1 Pressure Reducing Valve Vault
573-E.2 Pressure Reducing Valve Vault
573-E.3 Pressure Reducing Valve Vault
573-E.4 Pressure Reducing Valve Vault
573-E.5 Pressure Reducing Valve Vault
574 Air Release / CAV Valve Manhole
574 S Air Release / CAV Valve Manhole
575-A Heat Tape Installation for Air Release / CAV Valve
575-B Heat Tape Installation for Air Release / CAV Valve
576 Air Vent Stand Pipe
577-A Culinary Water - Irrigation Backflow Preventer
577-B Culinary & Secondary Water - Irrigation Swing Check Connection
578 Pipe Support

Trenching

580 Water Trench Bedding and Backfill
581 Water Trench Cut-off Wall

General

592 Meter Vault and Water Manhole Grading – Landscape Areas
593 Meter Vault and Water Manhole Collar – Pavement Areas
594.1 Water Service Line Flow Chart
594.2 Water Service Line Flow Chart
595 NFPA 13D or 13R Residential Fire Sprinkler Services
595 S NFPA 13D or 13R Residential Fire Sprinkler Services

596 Waterline Reference Marker
597 Waterline Casing
597 S Waterline Casing

DIVISIONS 600-800 NOT USED

DIVISION 900 TELECOMMUNICATION, ITS, AND SMART CITY

900.01 Telecommunication Standards
900.02 Supplemental Telecommunications Drawings

ATTACHMENTS

Attachment A

2025 Public Water Field Observation Guidelines
Forward
Disinfecting
Water System Flushing
Final Flushing
Hydrostatic Testing
Field Observation Quick Checklist – Water Line Installation
Field Observation Quick Checklist – Fire Hydrant Installation
Field Observation Quick Checklist – Water Meter Installation
Typical Process For Water System Construction
Water System Testing Summary Report

Attachment B

Old Town Stairway Construction Details & Plans

END OF CONTENTS

DIVISION 100 ADMINISTRATIVE & GENERAL
REQUIREMENTS

100.01 Introduction to Park City Engineering Standards

PART 1 GENERAL

1.1 SECTION INCLUDES

- A. Explanation of adopted engineering standard plans and specifications for construction improvements occurring within Park City right-of-way or properties. Park City Engineering Standards includes the most current versions of the:
- Park City Supplemental Standard Plans and Specifications (SSPS)
 - American Public Works Association Utah Chapter Manuals of Standard Plans and Specifications (UAPWA)

1.2 STANDARDS EXPLAINED

- A. Park City Municipal Corporation (PCMC) has adopted the most current versions of the UAPWA Manuals of Standard Plans and Standard Specifications, including approved amendments.
- B. These SSPS are intended to provide supplemental information to the most current version of the UAPWA.
- C. The Utah Manual of Uniform Traffic Control Devices (MUTCD) is adopted in its current edition at the time of permit approval.
- D. Technical Specifications produced by industrial or trade associations that are referred to in this document (ASTM, AASHTO, ANSI, etc.) are adopted as their most current version. Upon approval by the City Engineer or Designee, these Technical Specifications may be modified or deleted by appropriate notes identified on Approved Drawings.
- E. Drawings and specifications must additionally conform to Park City Municipal Code which can be found at the following link:
<https://parkcity.municipalcodeonline.com/book?type=ordinances#name=Preface>
- F. For standard specifications and drawings for sanitary sewer systems, Park City defers to Snyderville Basin Water Reclamation District (SBWRD). All sewer design and construction shall conform to the latest SBWRD requirements which can be found at: <https://www.sbwrduut.gov/new-connections/standards-and-specifications>
- G. Park City Water has developed standards different from the APWA that have been accepted by the Utah Division of Drinking Water. All Water system design and construction shall conform to Park City Water Standards contained herein.
- H. All public improvements constructed in the Park City's right-of-way, on Park City property, or facilities intended to be operated or maintained at any time by Park City are required to comply with these standards. Engineering standards are also applicable to private development site design, and all new development and redevelopment projects are required to adhere to these standards.
- I. Design Exceptions (DE) to specific standards must be approved in writing by the City Engineer or Designee. A request for a DE must be submitted to the City Engineer's Office. It will include documentation explaining why the standard cannot be reasonably met and thus justification for exception as well as the proposed modification. No exceptions will be granted that have a negative impact on public health, safety, or welfare. Examples of justification for approval include the following:
- The cost to obtain the standard significantly exceeds the expected benefit.
 - Required work to meet the standard is outside the scope of the project or could be better addressed by a future project.
 - Topography or other geographic conditions impose an undue hardship that cannot otherwise be mitigated.

Plan approval by the City Engineer or Designee does not grant or imply a waiver from standards unless noted explicitly by the City Engineer or Designee at the time of approval. Approval of a DE by the City Engineer or Designee can only be approved for work occurring within PCMC right-of-way. The City Engineer or Designee cannot approve a DE that occurs within the jurisdiction of another agency.

PART 2 PRODUCTS

Not Used

PART 3 EXECUTION

Not Used

END OF SECTION

100.02 Standards for Construction

PART 1 GENERAL

1.1 SECTION INCLUDES

- A. Park City Engineering has adopted the most current edition of the UAPWA Manual of Standard Plans and Manual of Standard Specifications, with the following exceptions.

1.2 APWA STANDARD DRAWING EXCEPTIONS

- A. Drawing exceptions:
- 205.1 Only type A curb is allowed
 - 238 Detectable warning surface –
 - Type P – Allowable on Main St and within Historic District
 - Type R – Not Allowed
 - Type T – Allowable everywhere: Material shall be Cast Iron
- B. Delete the following standard details, which are not permitted within Park City:
- 205.2 Curb and Gutter Type B
 - 205.3 Curb and Gutter Type H, HB30-7
 - 209 Curbs
 - 213 Waterway Transition Structure
 - 221.1 Flare Driveway Approach Type A
 - 221.2 Flare Driveway Approach Type B
 - 222 Saw-Cut Driveway Approach
 - 225 Open Driveway Approach
 - 229.1 Bridge Driveway Approach
 - 229.2 Bridge Driveway Approach Tie In
 - 232.1 Patterned Concrete Park Strip
 - 232.2 Patterned Concrete Crosswalk
 - 241 Parking Meter Post
 - 292 Street Name Signpost
 - 303 44” Frame and Cover for Cleanout box type A
 - 304 48” Cover and Frame
 - 305.1 51” Cover
 - 305.2 51” Frame A
 - 305.3 51” Frame B, C, D
 - 309.1 47 ¾” Vane Grate and Frame
 - 310 48” Grate and Frame
 - 320 Debris Grate Inlet
 - 321.2 Backflow preventer Pinch valve
 - 322 Curb Face Outlet box
 - 331.2 Cleanout box Type B
 - 331.3 Cleanout Box Type C
 - 332 Precast box
 - 335 Adjust reinforced concrete deck to grade
 - 341.2 Pipe pass through base
 - 360.2 Raise frame to grade—plastic form
 - 372 Area drain
 - Part 4 All Sanitary Sewer requirements
 - Part 5 All Culinary Water requirements
- C. Amend the following standard drawings:
- 231 Sidewalk – Add Wire Mesh as per 231 Sidewalk below
 - 315.1 Single Grate – Use bicycle safe grate and frame (STD. DWG. 309.2)
 - 315.2 Double Grate – Use bicycle safe grate and frame (STD. DWG. 309.2)

- 341.1 Precast Manhole – Add 12” of sediment storage as shown in APWA Standard Drawing – Plan 316 Combination catch basin and cleanout box
- D. Add the following guide as standard drawing:
 881 Park City Stair Standards

1.3 APWA STANDARD SPECIFICATION EXCEPTIONS

- A. Park City has adopted APWA 32 12 05. The standard asphalt mix design, unless approved otherwise, shall be per section 1.1.A.4(3) Roadway Structural Section.
- B. Delete the following sections in their entirety:
- 33 01 00 Water Distribution and Transmission
 - 33 11 11 Relocate Water Meters and Fire Hydrants
 - 33 12 16 Water Valves
 - 33 12 19 Hydrants
 - 33 12 33 Water Meter
 - 33 13 00 Disinfection
 - 33 16 13 Water Tank
 - 33 31 00 Sanitary Sewerage Systems

1.4 ENGINEER’S ESTIMATE UNIT PRICES

- A. The following table is provided as the City’s standard installed-cost reference for miscellaneous construction activities. When a developer does not submit their own construction cost estimate—required for calculating both the Construction Inspection Fees and the Improvement Completion Assurances—the City may rely on this table to establish the Engineer’s estimated costs.

ITEM	MEASUREMENT	UNIT COST
Silt Fence	LF	\$4.50
Revegetation	SY	\$4.60
Clear and Grub	SY	\$3.00
Removal of Gutter	LF	\$12.40
Placement of Gutter	LF	\$90.00
Removal of Asphalt	SF	\$10.00
Placement of Asphalt	SF	\$18.00
Removal of Cross Street Gutter	SF	\$15.50
Placement of Cross Street Gutter	SF	\$99.40
Removal of Sidewalk	SF	\$9.00
Placement of Sidewalk	SF	\$34.50
Paint	GALLON	\$33.50
Painted Symbols	EA	\$132.00
ADA Ramp	EA	\$4,630.00
Catch Basin	EA	\$3,450.00
Untreated Base	CY	\$53.00
Granular Borrow	CY	\$63.00
Excavation of Trench	CF	\$3.50
Excavation of Trench in Soils District	CF	\$10.10
Flow Fill of Trenching	CF	\$10.10

Installation of Waterline (Up to 4" Diameter)	LF	\$115.00
Installation of Waterline (6"-12" Diameter)	LF	\$173.00
ITEM	MEASUREMENT	UNIT COST
Installation of Water Meter Vault (Up to Vault for 1.5" Meter	EA	\$6,325.00
Installation of Water Meter Vault (Vault for 2"-4" Meter)	EA	\$8,625.00
Installation of Fire Hydrant	EA	\$11,500.00
Valve Collaring (Including Raising and Concreting)	EA	\$575.00
Installation of Valves (Up to 6")	EA	\$2,875.00
12" SD Pipe	LF	\$93.00
18" SD Pipe	LF	\$106.00
24" SD Pipe	LF	\$120.00
36" SD Pipe	LF	\$153.00
48" SD Pipe	LF	\$232.00
12" Concrete Pipe	LF	\$139.00
18" Concrete Pipe	LF	\$159.00
24" Concrete Pipe	LF	\$179.00
36" Concrete Pipe	LF	\$232.00
48" Concrete Pipe	LF	\$351.00
12"-18" End Section	EA	\$1,093.00
24"-36" End Section	EA	\$1,294.00
42"+ End Section	EA	\$1,610.00
Rip-Rap	CY	\$184.00
Retaining Wall	SF	\$106.00

PART 2 PRODUCTS Not Used

PART 3 EXECUTION Not Used

END OF SECTION

100.03 GENERAL IMPROVEMENT REQUIREMENTS & DESIGN GUIDELINES

PART 1 GENERAL

1.1 SECTION INCLUDES

Requirements for one-year warranty period, road-cut restrictions, improvement requirements, and general design guidelines related to roadway/construction improvements.

A. **One-Year Warranty Period:**

If within one year after completion any work is found to be defective, the contractor or developer shall promptly, without cost to the City, either correct such defective work or remove it from the site and replace it with non-defective work. If the contractor or developer do not promptly comply, or in an emergency where delay would cause serious risk of loss, injury or damage, the City may have the defective work corrected or the rejected work removed and replaced, and all direct and indirect costs of such removal and replacement, including compensation for additional professional services, shall be collected by the City in the manner most convenient to the City from the developer and contractor. Whatever sharing of cost may be agreed upon between the developer and contractor is strictly a private matter between the developer and the contractor.

B. **Road-Cut Requirements and Restrictions:**

Any cuts shall be performed with a saw or pneumatic tool to provide a straight, neat construction line. Cuts and edges of pavement patches must not be longitudinally aligned within the wheel path of the travel way. All cuts will require a repair in accordance with APWA Section 255 – Bituminous pavement T-patch. These conditions will be met unless otherwise approved by the City Engineer or Designee.

Any street cuts, asphalt paving or street patching operations shall only occur between April 15th and October 15th; when the surface temperature, upon which asphalt paving is to be placed, is at least fifty (50) degrees F and when the wind chill factor has not fallen below thirty (30) degrees F, unless otherwise approved by the City Engineer or Designee.

Between October 15th and April 15th, non-essential street cuts, asphalt paving, and street patching operations shall only be permitted by written authorization from the City Engineer or Designee and then only when conditions established by a proper review indicate that such placements are in the best interest of the City and the public. These conditions may include but are not limited to anticipated weather conditions showing temperatures above thirty-two (32) degrees F for the day of placement and an additional three (3) days after placement, no snow being predicted within this same time period, the anticipated project schedule being of minimal imposition, and good cause for the requirement of work during the time period of road cut prohibition rather than the work occurring after April 15.

Any asphalt placed after October 15 and before April 15 will be considered temporary, to be replaced under suitable conditions in accordance with APWA Section 255 – Bituminous pavement T-patch unless otherwise approved by the City Engineer or Designee.

Newly built roads, or roads which have been reconstructed, repaved, or overlaid shall not be cut into within three years of construction unless granted an exception by the City Engineer or Designee. Roads which have been slurry-sealed shall not be cut into within one year of placement unless granted an exception by the City Engineer or Designee. Any cut which has been granted an exception will require a repair in accordance with APWA Section 255 –

Bituminous pavement T-patch that spans the full width of the road to be paid for by the owner/contractor.

Essential road cuts are defined as road cuts required for emergency repairs to infrastructure and utilities which, if left untouched, have the potential to cause significant property damage or risk to safety.

C. **Concrete Cuts:**

Cuts through concrete (e.g. sidewalk, curb and gutter, rolled gutter) require full panel replacement. Concrete section must be replaced from joint to joint. No partial section replacements will be allowable unless by approval by the City Engineer or Designee.

D. **Required Improvements:**

The following improvements are required unless waived by the City Engineer or Designee on the basis of site conditions which make these improvements unnecessary. The design of the improvements will vary depending on site conditions but should be in alignment with Park City's Adopted Transportation Plans, and other similar planning documents adopted by the City that may cover the site or adjoining public properties. Unless otherwise stipulated all improvements shall be designed and built to the standards as adopted in this document, as required per the Park City Municipal Code and as required by other generally-accepted engineering standards.

1. Curb and gutter, culverts, inlet boxes, and other drainage improvements reasonably necessary to provide proper drainage in accordance with good engineering practices and the Park City Master Storm Drainage Plan.
2. Proper grading and drainage in conformance with Park City Municipal code Section 13-5-3 Long-Term Storm Water Management.
3. Wherever possible open channels shall be preserved for all major drainages shown on the Master Storm Drainage Plan. Culverting of these channels is not allowed unless approved by the City Engineer and Public Utilities Director or their designees. Landscaping and revegetation to stabilize soils may be required.
4. All roads shall be constructed of an all-weather surface such as asphalt or concrete. Pavements shall be designed on a site-specific basis by a registered professional civil engineer. Refer to Division 200.01.1.2.B Roadway Structural Section of these Supplemental Specifications and Division 32 Exterior Improvements of the most current UAPWA Specifications for all pavement design and construction requirements.
5. Both public and private streets shall be built in accordance with all provisions in this and other adopted Park City Code Documents. Streets should be designed using cross-sections shown in the Park City Municipal Library of Recommended Roadway Cross Sections. Due to right-of-way dimensional constraints within the City the recommended cross sections may not be applicable to all projects. If project constraints make the preapproved cross-sections infeasible, the City Engineer or Designee may grant exceptions on a case-by-case basis.

6. Projects which would create an unreasonable traffic impact, either for construction or for permanent access, whether by vehicles, bicycles, or pedestrians on any City street shall be required to structurally and/or geometrically improve those streets in a manner as determined by the City Engineer or Designee. These improvements will be required such that the improved street is structurally and geometrically capable of carrying both the temporary and permanent increases in traffic when analyzed by generally accepted engineering methods.
7. A study of geological hazards by a geologist or soils engineer may be required to be submitted for all sites unless City Staff specifically omits the requirement. Cuts and fills on each site shall be balanced to minimize hauling.
8. If a site is adjacent to a street identified within the Streets Master Plan as requiring additional right-of-way, the site may be required to dedicate right-of-way for public streets in accordance with the Streets Master Plan.
9. Sidewalks and/or pedestrian pathways, including all necessary ADA improvements, may be required to be installed in accordance with Park City's Adopted Transportation Plans or as required to serve the proposed project.
10. Trails may be required to be installed. If so, they shall be installed in accordance with the most current version of the Park City Trails Master Plan. Trails shall be constructed to meet the International Mountain Biking Association guidelines. Should a development establish trails, trail easements shall be dedicated on the plat and recorded with Summit County. Easements shall be established as listed:
 - a. Typical backcountry trail easements require a minimum of 10' in width and may require a professional trail designer to locate the trail appropriately in terms of grades and topography.
 - b. Neighborhood Trail easements may vary depending on the intent but typically range from 10-25' in width and should provide efficient and logical connections within and through a development.
 - c. Multi-use pathway easements typically require a minimum of 20' in width and should provide efficient and logical connections to existing facilities or destinations.
11. Streetlights, street signs, and traffic signs and markers. Operation and maintenance of streetlights is a City responsibility only when the light is at the intersection of two City streets. Street name signs shall be in accordance with Standard Drawings 239.1 and 293.2. Traffic signs and traffic markers (including but not limited to stop signs and pavement striping) shall be in accordance with the latest edition of the Manual on Uniform Traffic Control Devices (MUTCD). Streetlights shall be in accordance with UAPWA standards and specifications.
12. Fire hydrants are required at 500-foot intervals measured along public ways or walks or drives which are to be snow-plowed. All water mains serving a hydrant shall be a

minimum of eight-inch diameter. Each hydrant shall have an auxiliary gate valve located flanged to the tee on the water main.

13. All products and materials for public utilities shall be “MADE IN THE USA”. Steel and iron material products such as pipe, fittings, valves, manhole, meter vault, inlet box and valve box castings shall be “MELTED & MANUFACTURED IN THE USA”. If an item is not possible to source “MADE IN THE USA”, the developer/contractor may apply for an exception from the City Engineer or Designee with proof that a reasonable sourcing effort was made to comply with the “MADE IN THE USA” requirement.
14. A metallic tracer wire and high-visibility utility warning tape shall be placed over all underground utility lines.
15. All utilities and meter locations must be shown on submitted plans, including water and sewer laterals, power and phone cables, gas lines, and cable TV. Whenever a proposed project will alter, extend, or abandon sanitary sewer mains, all sewer construction shall be done according to standards established by Snyderville Basin Water Reclamation District (S.B.W.R.D.).
16. Sewer improvements as required by the S.B.W.R.D., including excess capacity as agreed upon between S.B.W.R.D. and the developer. Backfill over sewer lines in City streets or on City property shall be in accordance with these Specifications.
17. All connections to the City water system shall be inspected and metered unless otherwise approved by the City Engineer and Public Utilities Director or their Designees. All connections 4 inches in diameter or larger shall also be provided with a valve at the tee or property line and in other locations subject to the approval of the City Engineer and Public Works Director or their Designees. All connections, piping, and appurtenances on the consumer's side of the water meter or beyond a point 5 feet outside of the public right-of-way are to be owned and maintained privately, not by Park City, unless the infrastructure is dedicated to and accepted by the City. Any large addition to the water system, such as a new condominium project or subdivision, may also be required to install a master meter.
18. Infrastructure including, but not limited to, utility piping, poles, equipment, etc. that has been abandoned should be removed upon abandonment unless otherwise approved by the City Engineer or Designee.
19. A letter from each appropriate impacted utility company approving all utilities, including modification or protection but not limited to water and sewer laterals, power and phone cables, gas lines and cable TV can be required by the City Engineer or Designee prior to Park City approval. All utilities shall be placed underground unless otherwise approved by the City Engineer or Designee.
20. Water system improvements necessary to keep Park City's water storage and distribution system fully in accordance with recommendations from the Insurance

Services Office and Utah State Board of Health regulations. Improvements required include but are not limited to: reservoirs and appurtenances, including excess capacity as need to provide efficient long-term system operation, pressure reducing stations, pump stations, valves, air release valve vaults, meter vaults, water distribution lines, telemetry, and computer modeling by Park City or the consulting engineer of the City's choice as necessary to determine the impacts of a proposed development on the City water system. The City Engineer or Designee may require manhole-size valve vaults as per Std. Dwg. 709 at any valve. A completely-detailed design of each pump house will be required; scope of review includes but is not limited to exterior design and safety issues such as kill switches, ground faulting, and panel locations (2 feet off floor minimum). Pumps and motors shall have a minimum of 75% wire-to-water efficiency unless otherwise approved by City Engineer and Public Works Director or their Designees. To simplify parts inventories, water systems equipment manufacturers shall be as follows: pumps shall be manufactured by Aurora; motors by U.S. Electrical Motor; starters by Dayton; boxes and panels by Square D; chlorinators by Fischer and Porter; pump control valves by Cla-Val.

21. Locate transformers and pedestals outside of the right-of-way and within public utility easements. If the facilities cannot be located outside of the right-of-way shield may be required
22. Any staging area must be identified if requested by the City Engineer or Designee. Site survey information including detailed horizontal and vertical information relating to existing and future items may be required by the City Engineer or Designee.
23. Bus shelters, with an estimated value of \$6,000.00 each, are required for major developments along bus routes. If a bus shelter is provided, the developer's architect is required to use logos and signage in the design of the shelter but is encouraged to incorporate project design themes and features into the design of the shelter.
24. Snow storage sites and snow storage easements adequate to serve all plowed spaces within and adjacent to the developments. Snow which could be shed from roofs shall be adequately accommodated to eliminate the possibility of snow and ice falling on access ways to buildings.
25. Permanent survey controls such as brass cap measurements shall be set by a licensed professional land surveyor for all new developments.
26. As-built record drawings showing the as-built location of all public improvements. All subsurface improvements shall be tied to permanent surface improvements (e.g. survey monuments).

PART 2 PRODUCTS

Not Used

PART 3 EXECUTION

Not Used

END OF SECTION

DIVISION 200 STREETS

200.01 Roadway Standards

PART 1 GENERAL

1.1 GENERAL ROAD DESIGN STANDARDS

These standards shall be applicable to all developments/construction in Park City:

A. Roadway Design

1.1.A.1 Roadway Cross Slopes

The purpose of sloping on roadway cross sections is to provide a mechanism to direct water off the traveled way.

1. The standard cross slope to be used for new construction on a traveled way for all types of surfaces **shall be 2 percent**.
2. For resurfacing or widening (only when necessary to match existing cross slope), the minimum **shall be 1.5 percent and the maximum shall be 3 percent**.
3. On unpaved roadway surfaces, including gravel and penetration treated earth the cross slope **shall be 2.5 percent to 5.0 percent**.

1.1.A.2 Roadway Grade Requirements

1. Roadway **shall have a maximum grade of 10%**. Segments less than 250 ft. in length with a maximum grade of 12.5% may be acceptable with City Engineer or Designee and Fire Marshall approval.

1.1.A.3 Roadway Element Width Requirements

1. All roadway design elements shall have minimum widths in compliance with the following table.

TRANSPORTATION ELEMENT	PARK CITY STANDARD MINIMUM WIDTH [FT]	<i>MINIMUM WIDTH [FT] (ONLY APPLICABLE WITH CITY ENGINEER'S APPROVAL)</i>
Roadways		
Shoulder	4	2
Transit Shoulder	12	10
Parking Shoulder	9	7
Lane (Speed Limit <30MPH)	11	10
Transit Lane	11	11
On-Street Buffer between Travel Lane and Bike Lane	4	4
Bicycle Lane	5	4
Pedestrian Ways		
Sidewalk	6	4
Multi-Use Path	12	10
Back Country Trail	4	2
Natural Surface Pathway	10	10

2. Full roadway design sections shall be in conformance with all adopted code standards.

1.1.A.4 Roadway Structural Section

1. Table 1 below is minimum allowed material thicknesses for the various roadway geometric cross sections. The actual structural section shall be based on the volume of traffic and site specific soils engineering recommendations that shall be provided to the City Engineer’s office for review and approval prior to permit issuance.

Table 1. Minimum Roadway Structural Section Requirements

Roadway Section	Minimum Asphalt Thickness (in)	Minimum Commercial Roadbase Thickness (in)	Minimum CBR
Local Road - Non-old Town	4	9	70
Local Road - Old Town	4	9	70
Minor Residential Collector	4	9	70
Major Residential Collector	4	9	70
Commercial Collector	5	10	70
Non-UDOT Arterial	5	10	70
Pedestrian Section			
Multi-Use Path	4	8	70

2. Park City has adopted APWA 32 12 05. The standard asphalt mix design, unless approved otherwise, shall be a 3/8” maximum nominal aggregate size Superpave mix with PG 58-28 / 50Nd or other approved binder grade with a 15% maximum RAP content. The City Engineer or Public Works Director may approve alternates.
3. Park City has adopted APWA 32 11 23. The standard untreated base course (UTBC), unless approved otherwise, shall be Type 1 and meet UDOT Specification 02721. The City Engineer or Public Works Director may approve alternatives.
4. All curb, gutter, and sidewalk shall be concrete and installed per adopted APWA Standard Plans Part 2 – Roadway.
 - i. Class 4000, APWA Section 03 30 04
 Design and Installation Standards
 APWA Section 32 13 13 2.1
 6.5 bag Cement Content
 6% Air Entrainment
 4”-6” Slump
5. Machine Formed Concrete Placement – May be used upon the approval of the City Engineer and shall comply with all requirements of APWA Section 03 30 04 Class 4000, except as modified herein.
 - Target Slump 0 to 2 inches
 - Maximum aggregate size may be restricted (typically ≤ 1)

- Air entrainment 5 – 7%
- Equipment: Self-propelled slipform machine that consolidates concrete by internal vibration and produces the specified cross-section to required tolerances.

B. Construction Season

See 100.03 General Improvement Requirements and Design Guidelines Section 1.1-B Road-Cut Restrictions.

Any street cuts, asphalt paving or street patching operations shall only occur between April 15th and October 15th; when the surface temperature, upon which asphalt concrete is to be placed, is at least fifty (50) degrees F and/or when the wind chill factor has not fallen below thirty (30) degrees F, unless otherwise approved by the City Engineer or Designee.

C. Traffic Control

All construction activities shall minimize obstruction of vehicles, bicycles, or pedestrian traffic and prevent damage to completed work. In this regard, the Permittee shall keep the proper City Authorities continuously informed as to the location(s) of these operations.

Should construction activities partially or wholly obstruct a lane of travel (e.g. if traffic is unable to pass the work zone without entering the opposing lane of traffic) or will obstruct a sidewalk, it is required to obtain a Permit for a Closure of City Streets or Closure of City Sidewalks through the City Engineer’s office prior to beginning the work. The application for the permit shall include a traffic control plan that conforms to the Utah Manual of Uniform Traffic Control Devices (MUTCD)

Contact the City Engineer's office to apply for a Permit for authorization of Closure of City Streets or City Sidewalks.

In order that the effect to both the flow of traffic and damage to the new work is minimized, the permittee shall, at all times, provide approved traffic control measures (e.g. barricades, lights, flaggers and other traffic control devices) in accordance with their approved, MUTCD conforming traffic control plan and permit for closure of city streets/sidewalks and as may be required by law. All barricades needed overnight shall be lit in accordance with MUTCD.

All necessary personnel and/or devices, including any additional as directed by the City Engineer’s office, shall be provided solely at the permittee’s expense.

No City street or road shall be closed to vehicular traffic without first obtaining a Road Closure Permit from the City Engineer’s office and prior notification to affected emergency response authorities. If a road is closed without a Permit, the Contractor shall pay a fee in accordance with the Park City Municipal Code Fee Schedule Section 1.3.4 Road Closure Permit.

D. Right of Way: Grades Behind Gutter/Edge of Asphalt

When landscaping or excavating on City property or the City Right-Of-Way, the following conditions shall apply:

- a. The change in grade within the first five (5) feet behind the back of curb (BOC), or edge of asphalt (if there is no curb or gutter), shall not exceed six (6) inches plus or minus from the BOC grade elevation. The change in grade between five (5) feet and ten (10) feet

behind the BOC, or edge of asphalt (if there is no curb or gutter), shall not exceed three (3) feet plus or minus from the BOC grade elevation.

- b. Approval from City Officials is required prior to doing work on City Property. A permit may be required. Contact the City Engineer's Office for Permit requirements and/or Approval.

E. Snowmelt Systems

Surface runoff originating from snowmelt systems shall meet all criteria set forth in Section 13-5 Regulation And Enforcement of Storm Water Discharges Associated With Post-Construction Activities. Portions of snowmelt systems located over utility easements require a separate mechanical zone. Additionally, the utility provider may require a permanent utility encroachment that includes indemnification for the utility provider.

Proposed snowmelt systems located on a public right-of-way require Engineering Department approval. All snowmelt systems within or adjacent to the City Right-of-Way shall not drain to an unheated portion of sidewalk, hardscape, or roadway. All snowmelt systems in the ROW require a Work in the Right of Way permit and recordation of a permanent encroachment agreement. Additionally, these systems will need to have a separate mechanical zone for the ROW. If the City or associated utility provider needs to improve the ROW or access subsurface utilities, and the associated construction requires removal of a snowmelt system, then the property owner will be responsible for the replacement/ restoration of the system.

F. Plates (Steel/Rubber) Placed at Driveway Entrances

Steel plates or rubber inserts (both hereby known as “driveway plates”) placed at the bottom of driveways are not allowed. During new construction, driveway plates are prohibited to be installed. If a building permit is issued for work on an existing property that has an existing driveway plate, the driveway plate shall be removed prior to the final inspection.

Driveway plates can become hazardous projectiles if caught by snowplows and they can damage private property and public infrastructure and equipment. They can collect or stop debris creating street sweeping difficulties. The rubber inserts often obstruct the flow of storm water preventing proper system functionality.

If a driveway plate is thought to be necessary at a given location, an applicant may apply for City Engineer’s or Designee’s authorization of the driveway plate. If the City Engineer or Designee deems the driveway plate necessary and authorizes the driveway plate, the applicant must record an Encroachment Agreement for the placement (or continued presence) of a driveway plate in the City’s right-of-way.

G. Crosswalks

Crosswalks shall be installed per MUTCD Section 3C.03, but must, at a minimum, include the following improvements for visibility unless otherwise approved by the City Engineer or Designee:

- See Park City Crosswalk Treatment Guidelines for installation requirements <https://parkcity.gov/departments/transportation-planning/transportation-plans/crosswalk-treatment-guidelines>
- Ladder Striping per MUTCD Section 3C.07.
 - Exceptions:
 - If the crosswalk is within the school zone it should be marked with Longitudinal Bar Striping per MUTCD Section 3C.06.
 - Artistic crosswalk striping composed of repeating patterns may be accepted by the City Engineer or Designee for significant locations.

- Crosswalk transverse and longitudinal lines shall each be 12 inches wide.
- MUTCD Compliant Pedestrian Crosswalk Signage
- ADA Compliant Ramps including Cast-Iron Tactile Warning Surfaces

H. **Speed bumps or speed humps**

The placement of speed bumps or humps in the City roadway rights of way require approval by the City Engineer and are not recommended, in general, for placement within City roadway rights of way. They pose problems for snow removal. Thus, for safety and liability reasons these facilities require special approval by the City Engineer prior to their installation. The City recommends that other traffic calming measures be considered before the placement of speed bumps/humps.

PART 2	PRODUCTS	Not Used
PART 3	EXECUTION	Not Used

END OF SECTION

200.02 Standard Roadway Drawings

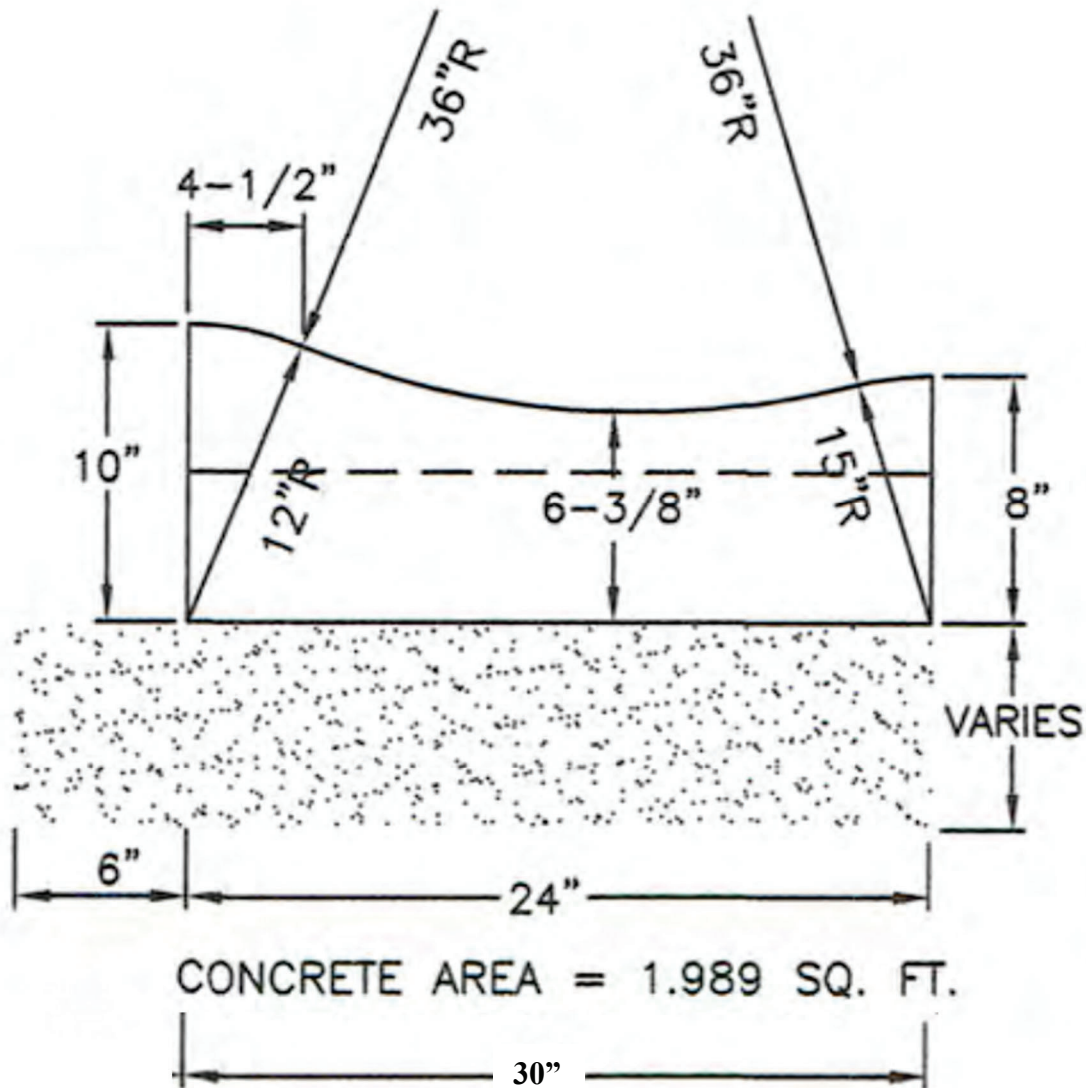

Type G

30" Gutter to be used when repairing existing or when determined in new project design.

 PARK CITY MUNICIPAL CORPORATION ENGINEERING	DATE	Curb Type G	STD. PLAN
	6/2026		205.4
	REV.		

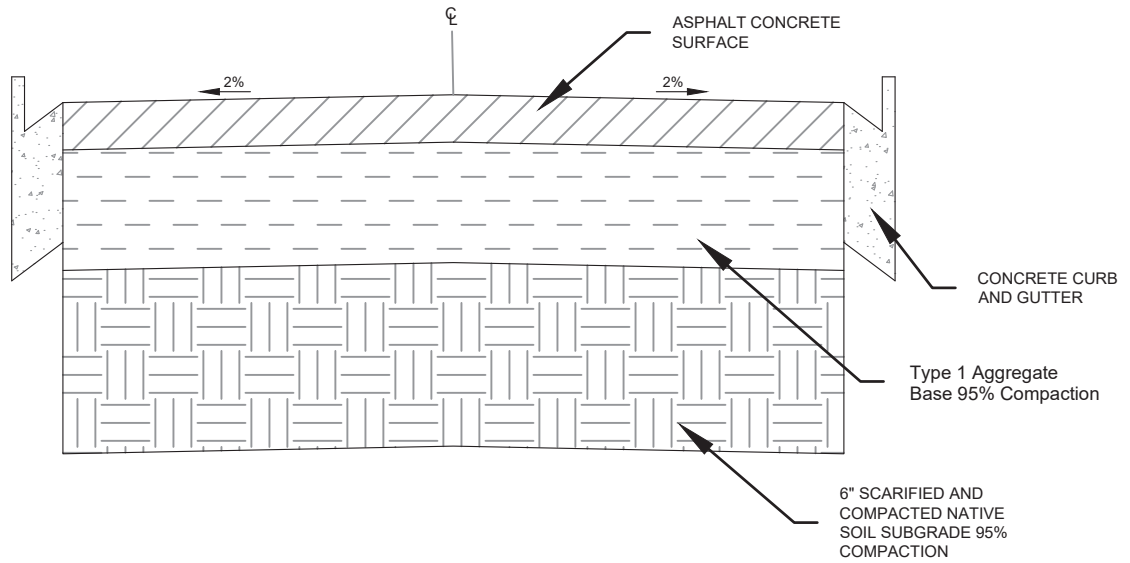

TYPICAL STREET STRUCTURAL CROSS SECTION
N.T.S.

Roadway Section	Minimum Asphalt Thickness (in)	Minimum Commercial Roadbase Thickness (in)	Minimum CBR
Local Road - Non-old Town	4	9	70
Local Road - Old Town	4	9	70
Minor Residential Collector	4	9	70
Major Residential Collector	4	9	70
Commercial Collector	5	10	70
Non-UDOT Arterial	5	10	70
Pedestrian Section			
Multi-Use Path	4	8	70

NOTES:

1. ALL STREET STRUCTURAL PAVEMENT SECTIONS SHALL BE BASED ON A MINIMUM CBR VALUE OF 70.
2. STREET STRUCTURAL PAVEMENT SECTION CALCULATIONS SHALL BE SUBMITTED TO & APPROVED BY THE CITY ENGINEER.
3. A SAFETY FACTOR OF 0.2 SHALL BE APPLIED IN PAVEMENT CALCULATIONS.
4. SOILD TEST DATA USED IN THE DESIGN CALCULATIONS SHALL BE FURNISHED BY A SOILS TESTING LABORATORY REPORT TO BE SIGNED AND SEALED BY A UT REGISTERED CIVIL ENGINEER.

	DATE	STREET STRUCTURAL DETAILS	STD. PLAN
	8/2020		205.5
	REV.		

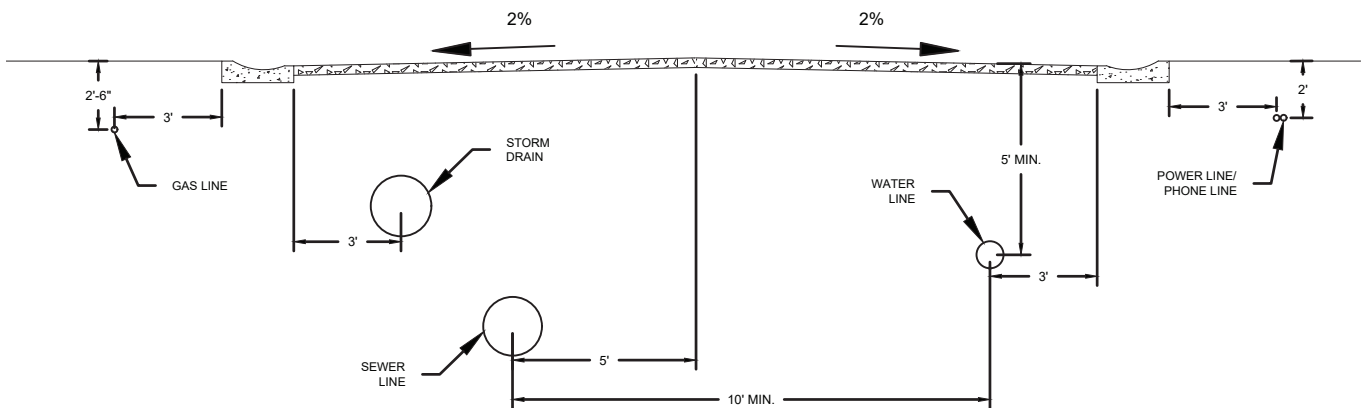

NOTE:

1. WATER LINE TO BE LOCATED ON THE NORTH AND EAST SIDE OF STREETS.
2. GAS LINE TO BE LOCATED ON THE SOUTH AND WEST SIDE OF STREETS OR WHERE DESIGNATED BY THE CITY ENGINEER AND/OR THE DIRECTOR OF PUBLIC WORKS.
3. PAVEMENT SECTION TO BE DESIGNED BY A PROFESSIONAL CIVIL ENGINEER.

	DATE	TYPICAL STREET SECTION FOR UTILITIES	STD. PLAN
	8/2020		208
	REV.		

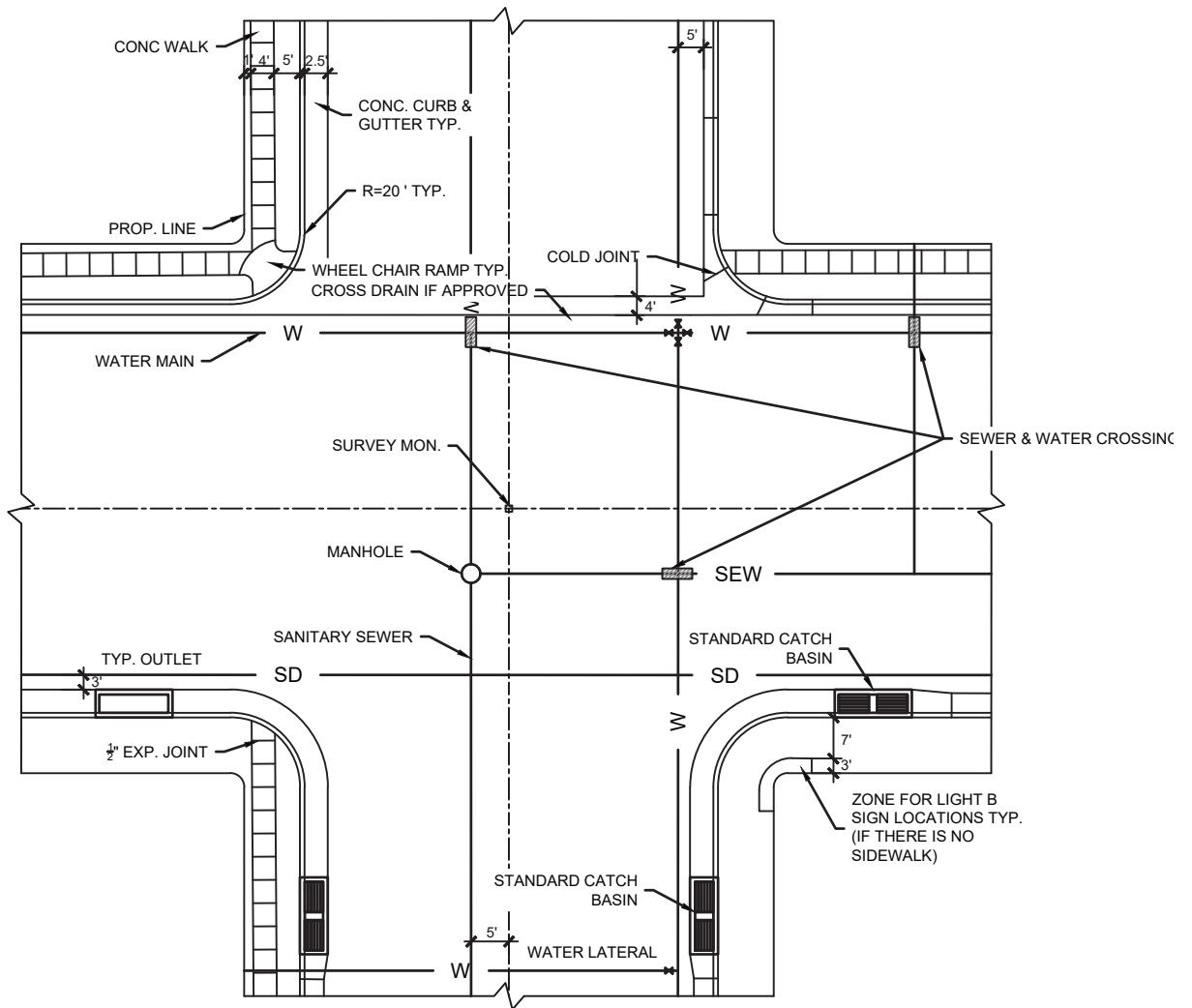

NOTE:

1. SANITARY SEWER LINES MAY VARY FROM THE LOCATION SHOWN. IN NO CASE SHALL THE SANITARY SEWER OR LATERAL BE PLACED LESS THAN 10 FEET FROM A PARALLELING POTABLE WATER LINE (INCLUDING SERVICE LINES). ALL SEWER LINES AND MANHOLES SHALL BE INSTALLED AT A MINIMUM OF 4 FEET FROM THE EDGE OF ALL CURB AND GUTTER WHEREVER POSSIBLE. SANITARY SEWER SHALL BE INSTALLED ON THE DOWNHILL SIDE OF THE STREET.
2. WHEN A SANITARY SEWER AND A WATER LINE CROSS, THE TOP OF THE SANITARY SEWER SHALL BE NO LESS THAN 18 INCHES BELOW THE BOTTOM OF THE WATER LINE.
3. WATER VALVES AND FIRE HYDRANTS SHALL BE LOCATED AS APPROVED BY THE CITY (5 FOOT MINIMUM SEPARATION BETWEEN WATER LINE AND ANY OTHER UTILITY).
4. NO WATER LINE SMALLER THAN 8-INCH DIAMETER SHALL BE INSTALLED WITHOUT APPROVAL OF THE CITY ENGINEER. NO WATER CONNECTION SHALL BE MADE WITHOUT APPROVAL OF THE PUBLIC WORKS DIRECTOR.
5. SIDEWALK ON BOTH SIDES OF THE STREET MAY BE REQUIRED BY THE CITY.



DATE	8/2020
REV.	

**TYPICAL INTERSECTION
LOCATIONS OF UTILITES**

STD. PLAN	210
-----------	-----

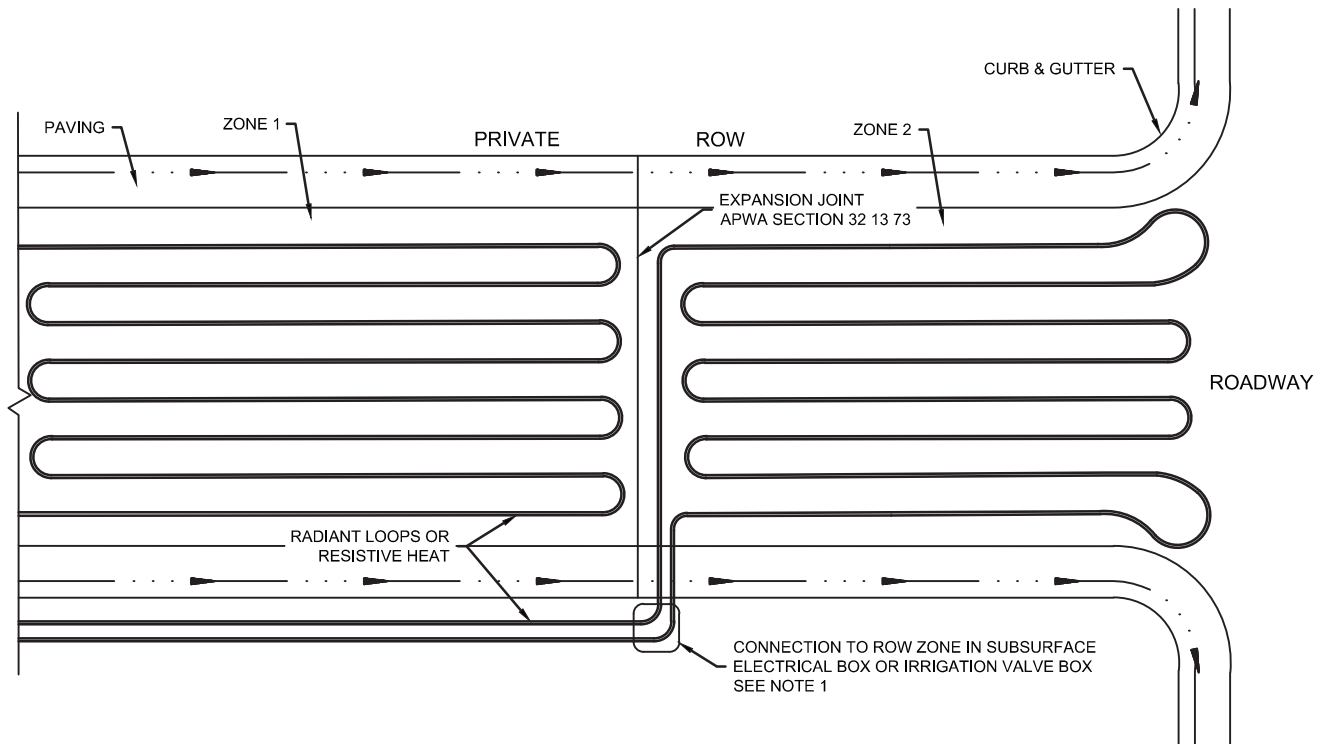

PERSPECTIVE VIEW

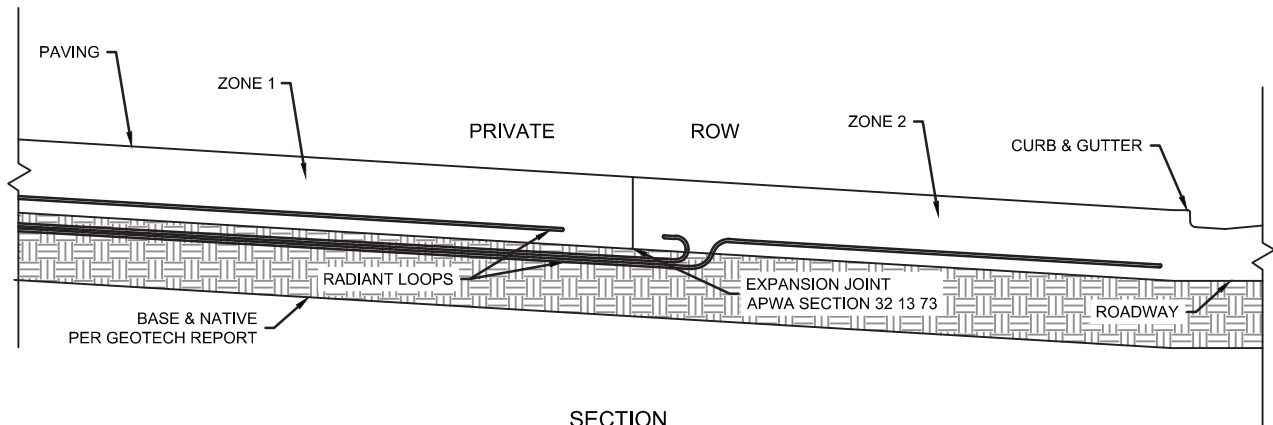

SECTION

NOTES:

1. REFER TO APWA STANDARD PLAN 731 FOR THE JUNCTION BOX, OR USE AN EQUAL ELECTRICAL CONNECTION THAT COMPLIES WITH LOCAL CODE.
2. THE HEATED PORTION OF A DRIVEWAY WITHIN THE ROW SHALL BE POWERED BY A SEPARATE ZONE THAT CAN BE SHUT OFF OR REPAIRED WITHOUT DAMAGE OR INTERRUPTIONS TO THE REMAINDER OF THE SYSTEM.
3. THE CONNECTION TO THE ROW ZONE SHALL INCLUDE A JUNCTION BOX LOCATED OUTSIDE OF THE PAVED AREA WHERE THE ROW ZONE CAN BE SHUT OFF OR REROUTED IN CASE OF DAMAGE.
4. A CONSTRUCTION JOINT/BREAK IN PAVEMENT SHALL BE CONSTRUCTED ALONG THE ROW LINE, BETWEEN HEATED ZONES, TO FACILITATE REMOVAL OF PAVEMENT IN THE ROW WITHOUT DAMAGE TO THE REMAINING DRIVEWAY.

NOT TO SCALE

	DATE	HEATED PAVEMENT	STD. PLAN
	11/2020		217
	REV.		

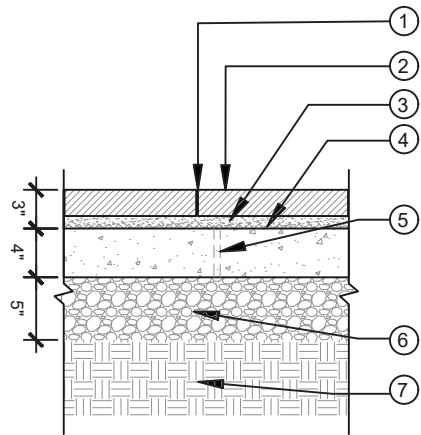

- ① BUTT JOINT. TYP. (POLYMERIC SAND)
- ② GRANITE STONE PAVER (2" X 12" X 12")
- ③ SAND SETTING BED: 1/2" MIN. & 1" MAX
- ④ GEOTEXTILE FABRIC; SEE SPECS
- ⑤ CONC. SLAB WITH 1/2" DIA. WEEP HOLES @ 18" O.C. GRID.
- ⑥ 95% COMPACTED BASE COURSE (75% FRACTURED FACE STONE)
- ⑦ 95% COMPACTED UNDISTURBED SUBGRADE

SECTION

NOTE:
1. TRANSITIONS TO ADJACENT PAVING MATERIALS ARE TO BE FLUSH.

1 GRANITE STONE PAVER - SECTION
NTS

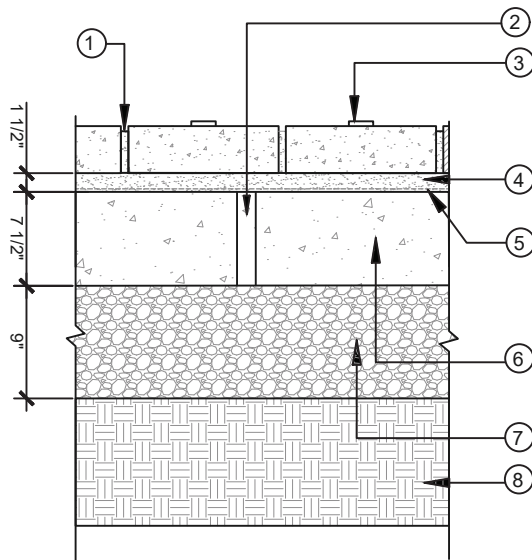

- ① 1/16" SAND JOINT, TYP.
- ② 1" DIA. WEEP HOLE @ 18" O.C. GRID
- ③ TRUNCATED DOME 4"x8" PACIFIC CLAY COLOR: DARK IRON SPOT
- ④ SAND SETTING BED; 1/2" MINIMUM AND 1" MAXIMUM SAND THICKNESS
- ⑤ FILTER FABRIC; SEE SPECS
- ⑥ CONCRETE PAVING-TYPE 1
- ⑦ UNTREATED BASE COURSE
- ⑧ 95% COMPACTED/UNDISTURBED SUBGRADE

SECTION

NOTE:
1. ANY PAVERS THAT ARE CUT TO FIT MUST BE AT LEAST 1/2 THE ORIGINAL 4"x8" PAVER.

2 TRUNCATED DOME BRICK PAVING
NTS

	DATE	MAIN STREET SIDEWALK DETAILS	STD. PLAN
	3/2020		230.1-A
	REV.		

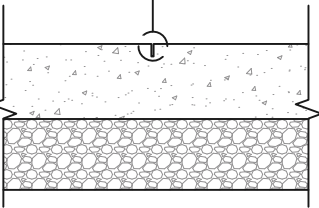
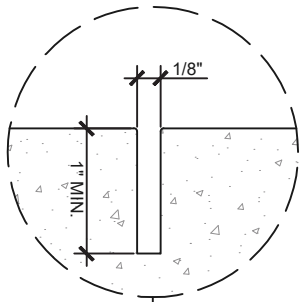

SAW-CUT CONTROL JOINT

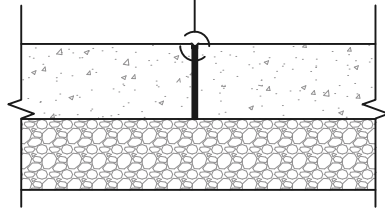
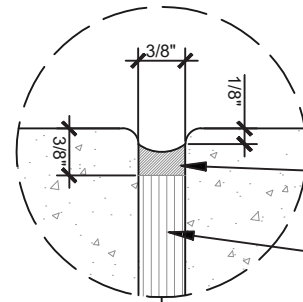

EXPANSION JOINT (E.J.)

- ① SEALANT AT ALL EXPOSED E.J. AND AT EXISTING STRUCTURES
- ② NON-EXTRUDED, BITUMINOUS TYPE RESILIENT FILLER

NOTE:
 1. SUB-SLAB TO RECEIVE EXPANSION AND CONTROL JOINTS. ALIGN WITH JOINTS AS SHOWN ON PLAN FOR BANDING.

3 CONCRETE PAVING CONTROL JOINTS
 NTS

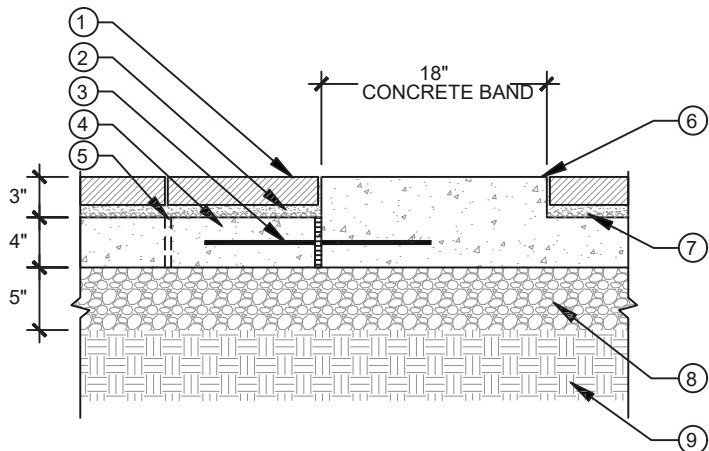

- ① GRANITE STONE PAVER (2" X 12" X 12")
- ② SAND SETTING BED; 1/2" MINIMUM AND 1" MAXIMUM SAND THICKNESS
- ③ 1/2" EXP. JT. MAT'L. 12" x 18" STEEL DOWEL W/ SLEEVE 24" O.C.
- ④ CONCRETE BASE
- ⑤ 1" DIA. WEEP HOLE @ 18" O.C. GRID
- ⑥ CONCRETE BANDING FLUSH WITH BRICK PAVERS, MEDIUM BROOM FINISH
- ⑦ FILTER FABRIC; SEE SPECS
- ⑧ 95% COMPACTED BASE COURSE (75% FRACTURED FACE)
- ⑨ UNDISTURBED SUBGRADE OR 95% COMPACTION

4 CONCRETE BAND BETWEEN GRANITE PAVERS SECTION
 SCALE: 1" = 1'

	DATE	MAIN STREET SIDEWALK DETAILS	STD. PLAN
	3/2020		230.1-B
	REV.		

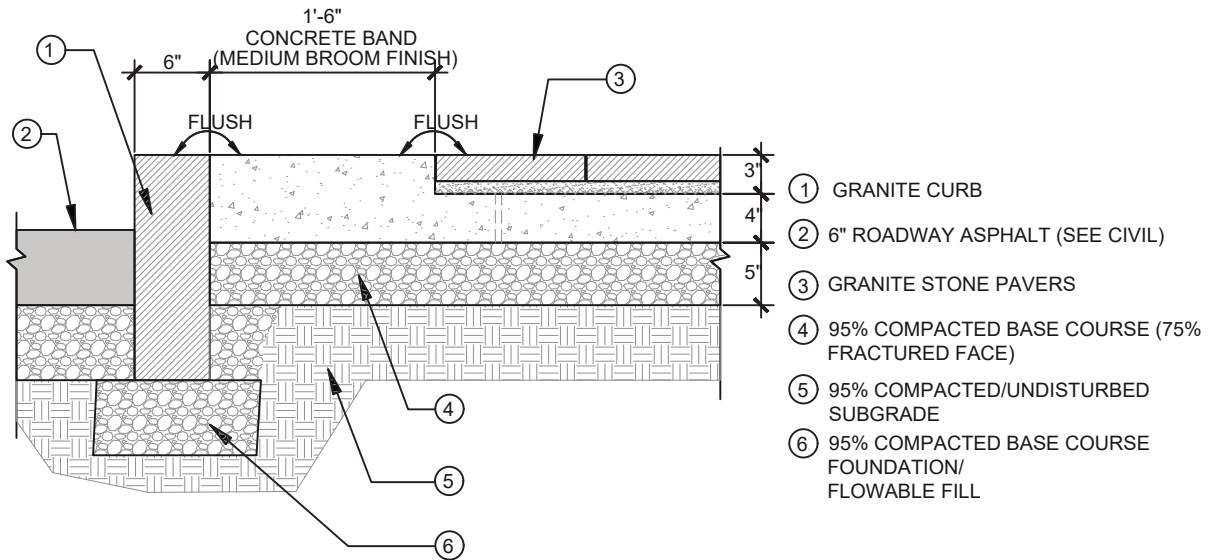

SECTION

NOTE:

1. CONTRACTORS OPTION TO FILL ALL VOIDS WITH FLOWABLE FILL. PROVIDE COSTS FOR OWNER APPROVAL.

⑤ CONCRETE BAND AT GRANITE CURB SECTION
NTS

	DATE	MAIN STREET SIDEWALK DETAILS	STD. PLAN
	3/2020		230.1-C
	REV.		

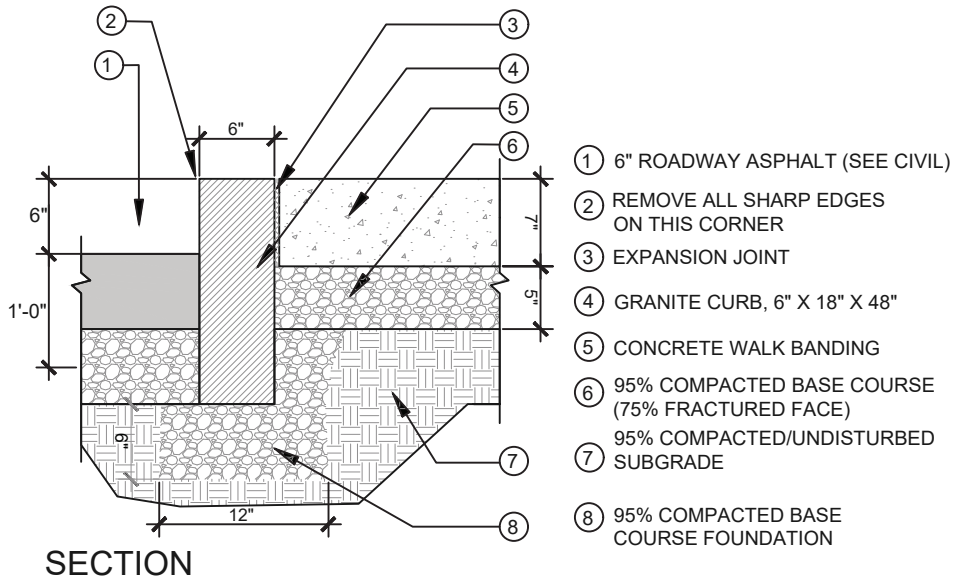

MATERIAL:

1. STONE FOR GRANITE CURBING SHALL BE HARD AND DURABLE GRANITE OF LIGHT COLOR AND UNIFORM TEXTURE, NEITHER STRATIFIED NOR LAMINATED. IT SHALL BE FREE FROM SEAMS AND EVIDENCE OF WEAKENING OR DISINTEGRATION AND SHALL HAVE GOOD, SMOOTH SPLIT FACES.
2. THE ENDS OF ALL STONES SHALL BE SQUARE WITH THE PLANES OF THE TOP AND FACE, AND SO FINISHED THAT WHEN STONES ARE PLACED END TO END AS CLOSELY AS POSSIBLE, NO SPACE MORE THAN 1/2 INCH SHALL BE SHOWN FOR FULL WIDTH.
3. ALL SHARP EDGES OF STONE TO BE REMOVED FROM CORNER ON STREET SIDE OF CURB.

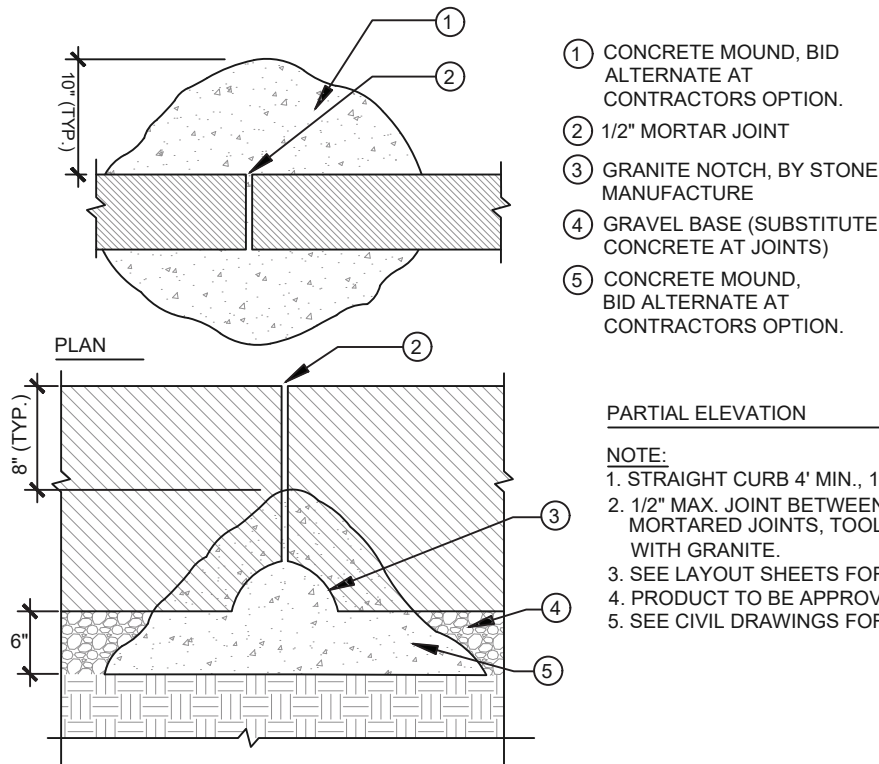

⑥ GRANITE CURB - SECTION
NTS

	DATE	MAIN STREET SIDEWALK DETAILS	STD. PLAN
	3/2020		230.1-D
	REV.		

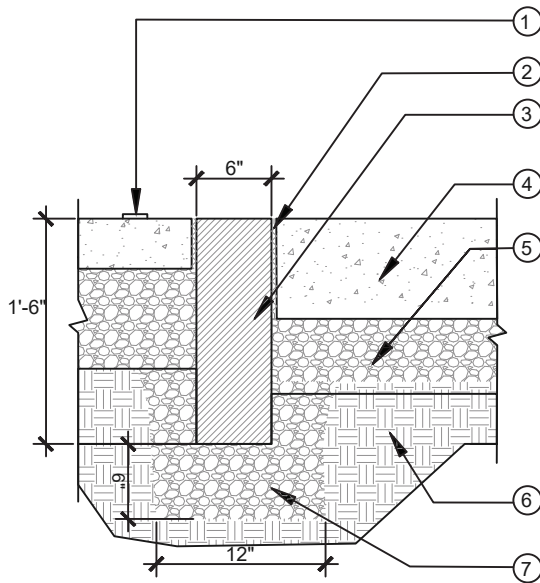

- ① TRUNCATED DOME BRICK PAVING
- ② EXPANSION JOINT
- ③ GRANITE CURB, 6" X 18" X 48" INSTALLED FLUSH WITH CONCRETE
- ④ VEHICULAR CONCRETE PAVING
- ⑤ 95% COMPACTED BASE COURSE (75% FRACTURED FACE)
- ⑥ 95% COMPACTED/UNDISTURBED SUBGRADE
- ⑦ 95% COMPACTED BASE COURSE FOUNDATION/ FLOWABLE FILL

SECTION

⑦ GRANITE CURB - AT DRIVEWAY
NTS

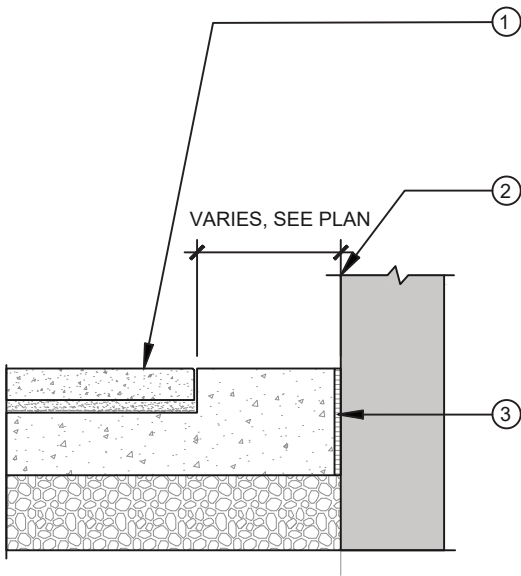

- ① GRANITE STONE PAVERS
- ② BUILDING FACE
- ③ EXPANSION JOINT AT ALL ADJACENT WALLS AND PAVEMENTS

NOTE:
1. SEE CIVIL DRAWINGS FOR ELEVATIONS AT BUILDING.

⑧ TRANSITION AT BUILDING
NTS

	DATE	MAIN STREET SIDEWALK DETAILS	STD. PLAN
	3/2020		230.1-E
	REV.		

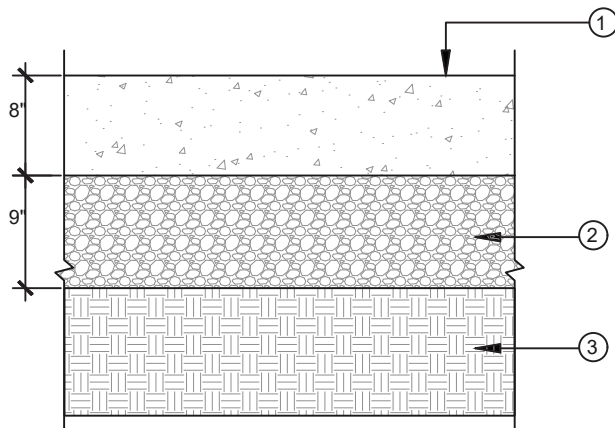

SECTION

NOTE:

- 1. MEDIUM BROOM FINISH
- 2. SEE PLAN FOR SCORE AND EXPANSION JOINT LOCATIONS

- ① CONCRETE PAVING (MEDIUM BROOM FINISH)
- ② 95% COMPACTED BASE COURSE (75% FRACTURED FACE)
- ③ 95% COMPACTED/UNDISTURBED SUBGRADE

9 VEHICULAR CONCRETE PAVING
NTS

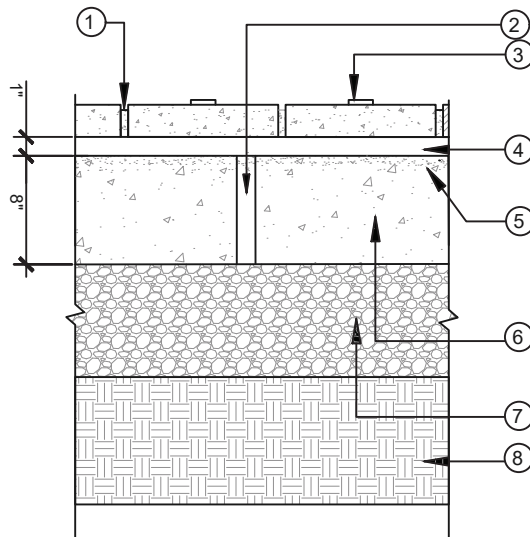

- ① 1/8" SAND JOINT, TYP.
- ② 1" DIA. WEEP HOLE @ 18" O.C. GRID
- ③ BRICK PAVER - VEHICULAR RATED
- ④ SAND SETTING BED; 1/2" MINIMUM AND 1" MAXIMUM SAND THICKNESS
- ⑤ FILTER FABRIC; SEE SPECS
- ⑥ CONCRETE PAVING
- ⑦ UNTREATED BASE COURSE
- ⑧ 95% COMPACTED/UNDISTURBED SUBGRADE

SECTION

NOTE:

- 1. ANY PAVERS THAT ARE CUT TO FIT MUST BE AT LEAST 1/2 THE ORIGINAL 4"x8" PAVER SIZE
- 2. HERRINGBONE PATTERNS IN TRAFFIC AREAS.
- 3. USE POLYMERIC SAND IN JOINTS.

10 VEHICULAR BRICK PAVING
NTS

	DATE	MAIN STREET SIDEWALK DETAILS	STD. PLAN
	3/2020		230.1-F
	REV.		

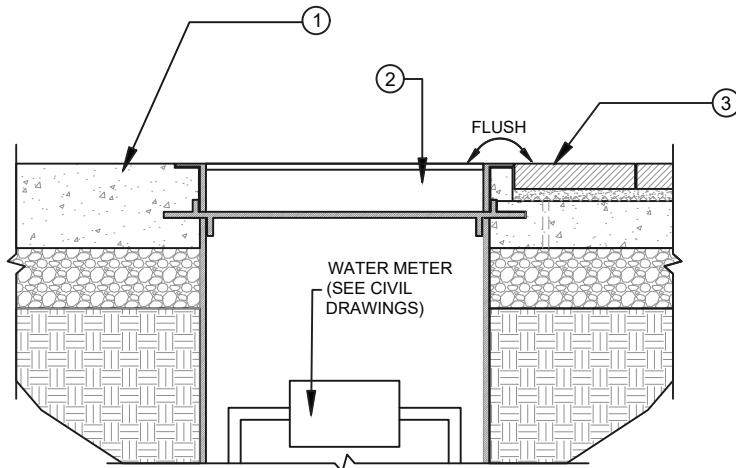

NOTE:
 1. COORDINATE LOCATION IN FIELD WITH CIVIL.
 2. CUT STONE IN FIELD (1/8" MAX. JOINT).
 3. ADJACENT MATERIAL MAY VARY FROM GRANITE TO CONCRETE.
 SEE LAYOUT PLAN FOR CONDITION.

SECTION

1 CONCRETE / GRANITE STONE PAVERS AT WATER METER - SECTION
 NTS

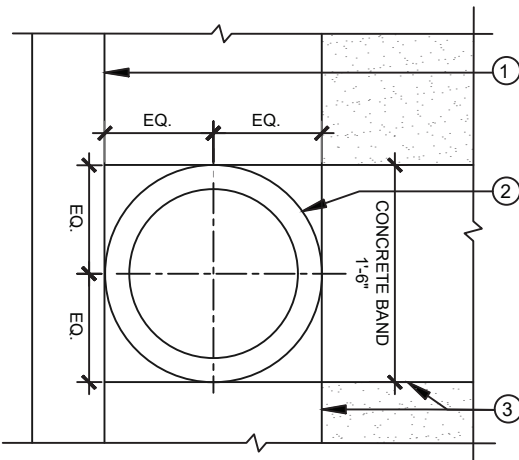

NOTE:
 1. STREET LIGHT BASE IS TO BE INSTALLED FLUSH WITH SIDEWALK ON HIGH SIDE. GROUT BOTTOM.
 2. CENTER BASE IN CONCRETE SCORING.
 3. SEE LIGHTING ENGINEERS DRAWING FOR FOOTING SIZE.

2 STREET LIGHT BASE
 NTS

	DATE	MAIN STREET SIDEWALK DETAILS	STD. PLAN
	3/2020		230.2-A
	REV.		

- ① ROADWAY ASPHALT (SEE CIVIL)
- ② GRANITE CURB
- ③ EXPANSION JOINT BEHIND CURB
- ④ CONC. SLAB WITH 1/2" DIA. WEEP HOLES @ 18" O.C. GRID.
- ⑤ GRANITE STONE PAVERS
- ⑥ BUILDING FACE OR ADJACENT STRUCTURE TO BE PROTECTED THROUGHOUT CONSTRUCTION.
- ⑦ EXPANSION JOINT AT BUILDING

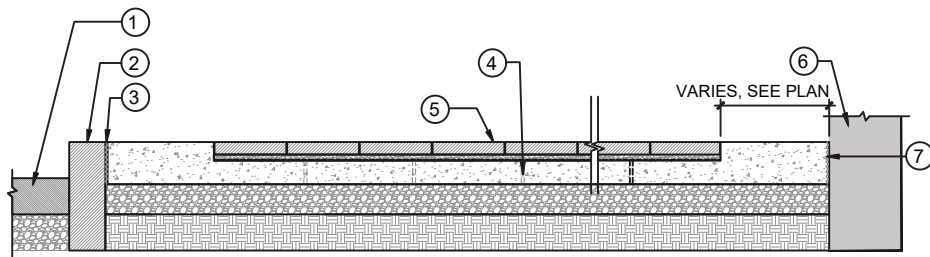

③ SIDEWALK SECTION TYP.
NTS

	DATE	MAIN STREET SIDEWALK DETAILS	STD. PLAN
	3/2020		230.2-B
	REV.		

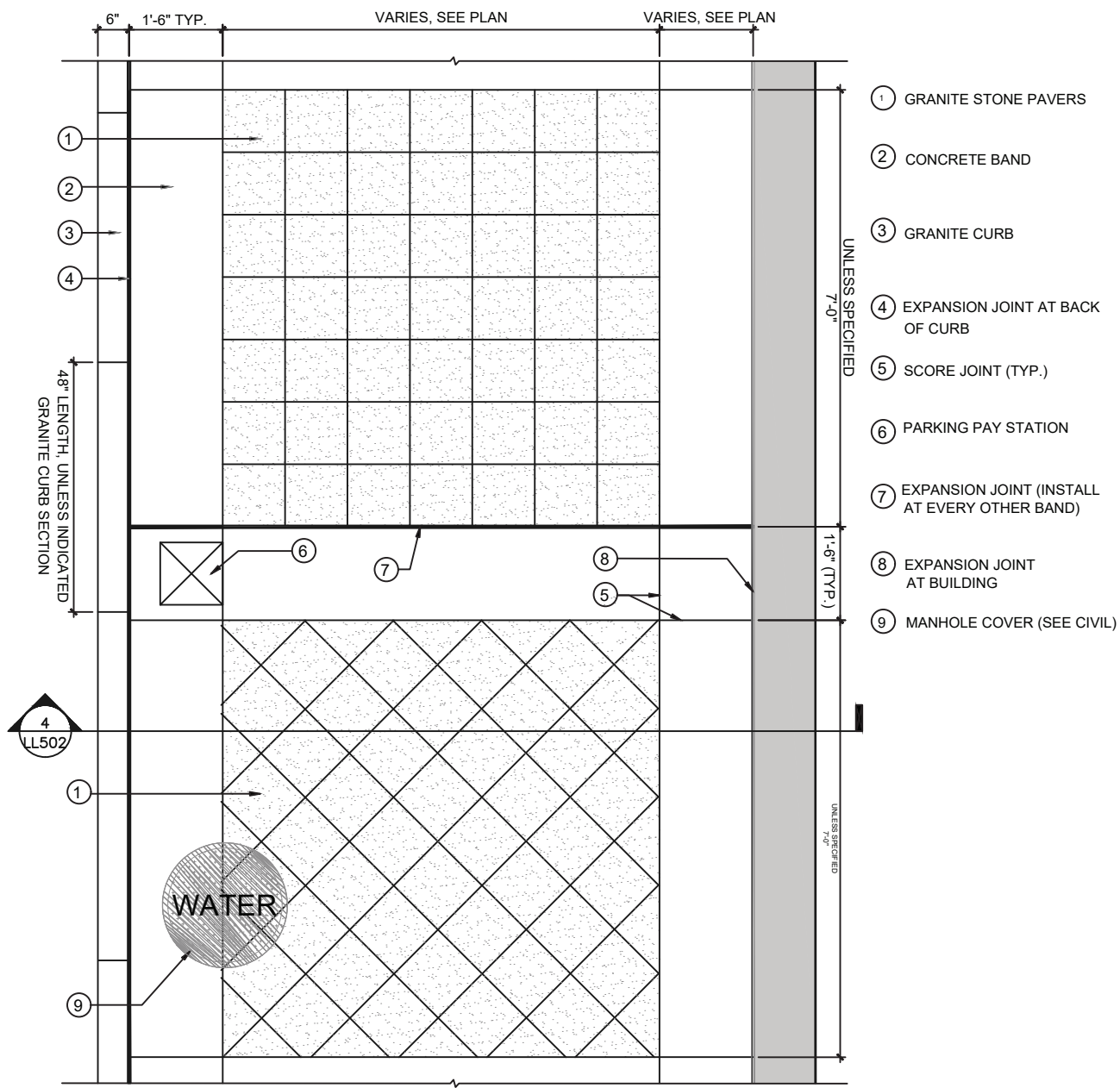

NOTE:

1. SEE LAYOUT PLAN FOR GRANITE PATTERN LOCATION.
2. BEGIN LAYOUT OF GRANITE PATTERN ON NORTH END OF EACH PANEL ON BUILDING SIDE OF WALK.
3. CONTRACTOR TO RAISE ALL UTILITY BOXES IN SIDEWALK TO BE FLUSH WITH NEW SIDEWALK ELEVATIONS, REGARDLESS OF CONDITION SHOWN ON DRAWINGS.
4. ALL BOXES AND LIDS TO BE STEEL OR CONCRETE. NO PLASTIC PERMITTED.
5. CONCRETE FINISH TO BE MEDIUM BROOM, TEXTURE TO RUN PERPENDICULAR TO CURB.
6. INSTALL EXPANSION JOINT ON UPHILL SIDE FOR EVERY OTHER PANE.

④ **SIDEWALK PAVING PATTERN - ENLARGEMENT PLAN**
 NTS

	DATE	MAIN STREET SIDEWALK DETAILS	STD. PLAN
	3/2020		230.2-C
	REV.		

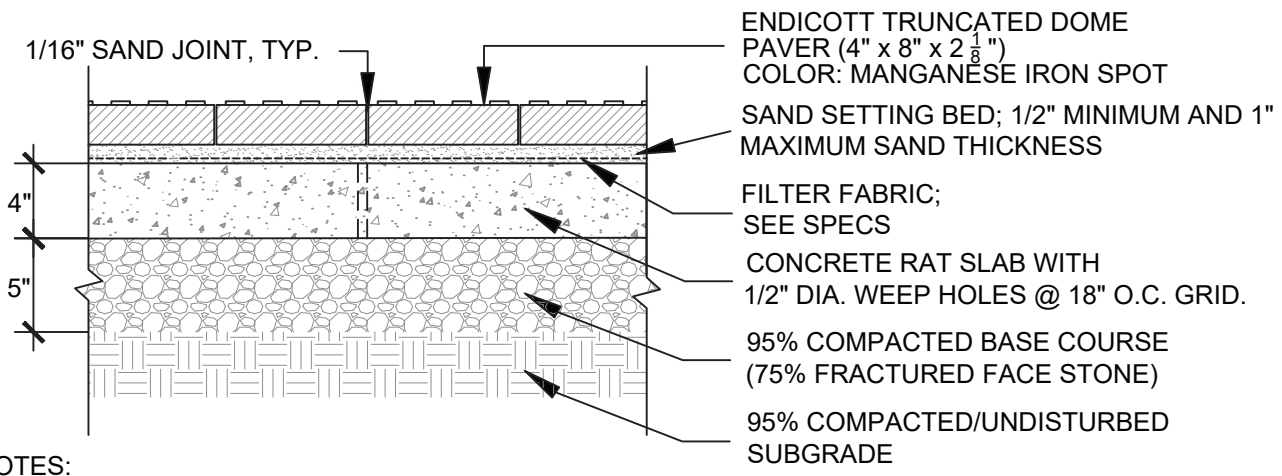

NOTES:
 1. ANY PAVERS THAT ARE CUT TO FIT MUST BE AT LEAST 1/2 THE ORIGINAL 4"x8" PAVER

1 PEDESTRIAN TRUNCATED DOME BRICK PAVING - SECTION

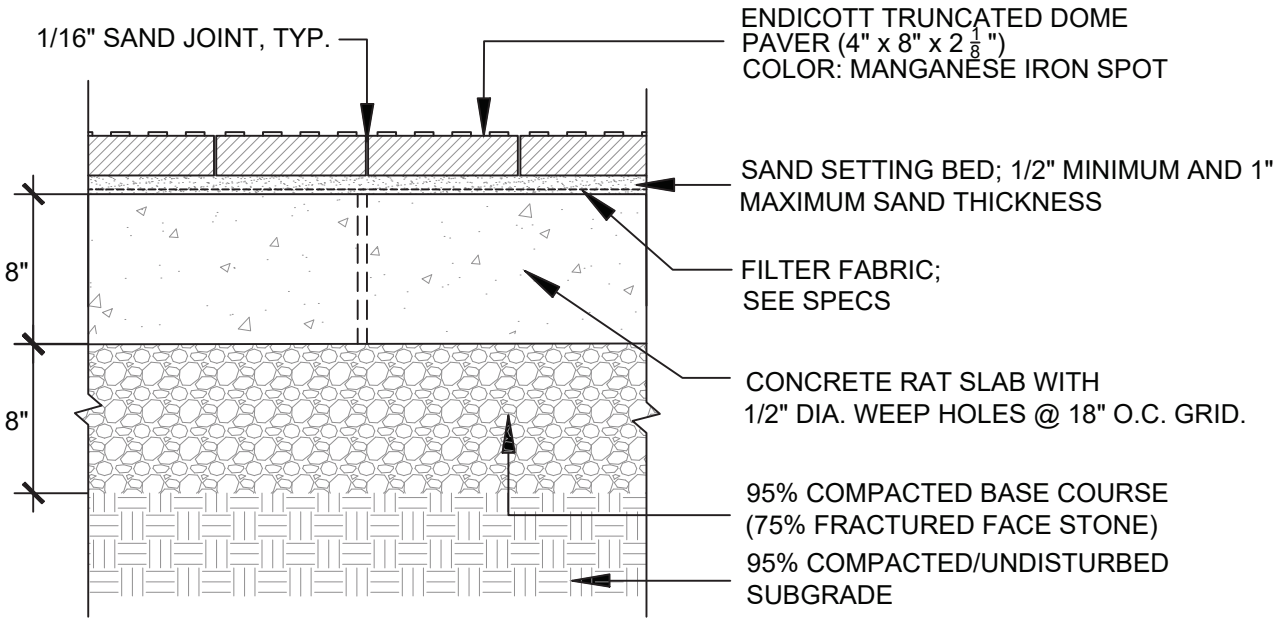

NOTES:
 1. ANY PAVERS THAT ARE CUT TO FIT MUST BE AT LEAST 1/2 THE ORIGINAL 4"x8" PAVER

2 VEHICULAR TRUNCATED DOME BRICK PAVING - SECTION
 N.T.S.

	DATE	MAIN STREET SIDEWALK DETAILS	STD. PLAN
	3/2020		230.3-A
	REV.		

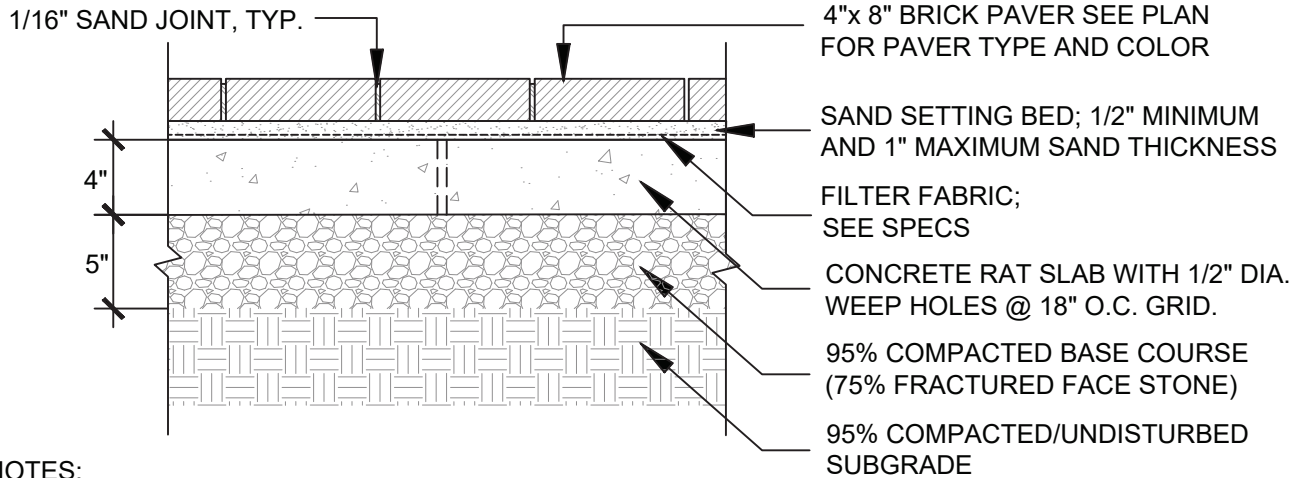

NOTES:

1. ANY PAVERS THAT ARE CUT TO FIT MUST BE AT LEAST 1/2 THE ORIGINAL 4"x8" PAVER.
2. TRANSITIONS TO ADJACENT PAVING MATERIALS ARE TO BE FLUSH.

3 PEDESTRIAN BRICK PAVING - SECTION
N.T.S.

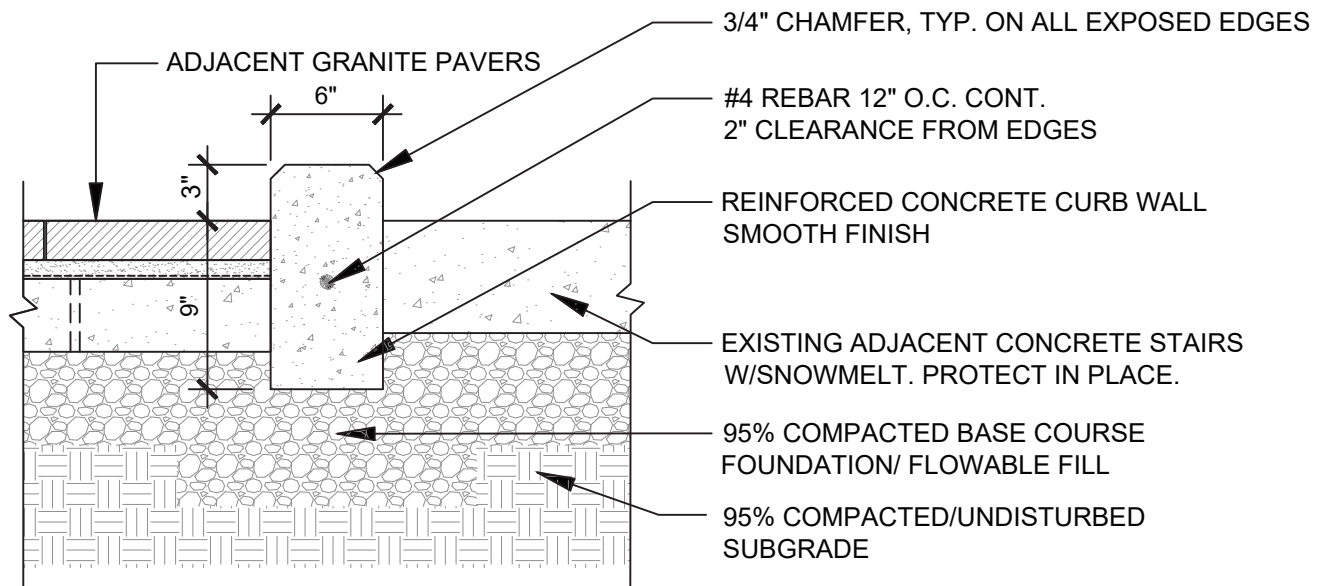

NOTES:

1. EXTRA PRECAUTION IS TO BE TAKEN WITH ADJACENT EXISTING CONCRETE STAIRS TO PROTECT SNOWMELT.
2. SEE CIVIL PLANS FOR FINISH ELEVATIONS.

4 CONCRETE CURB WALL AT STAIRS - SECTION
N.T.S.

	DATE	MAIN STREET SIDEWALK DETAILS	STD. PLAN
	3/2020		230.3-B
	REV.		

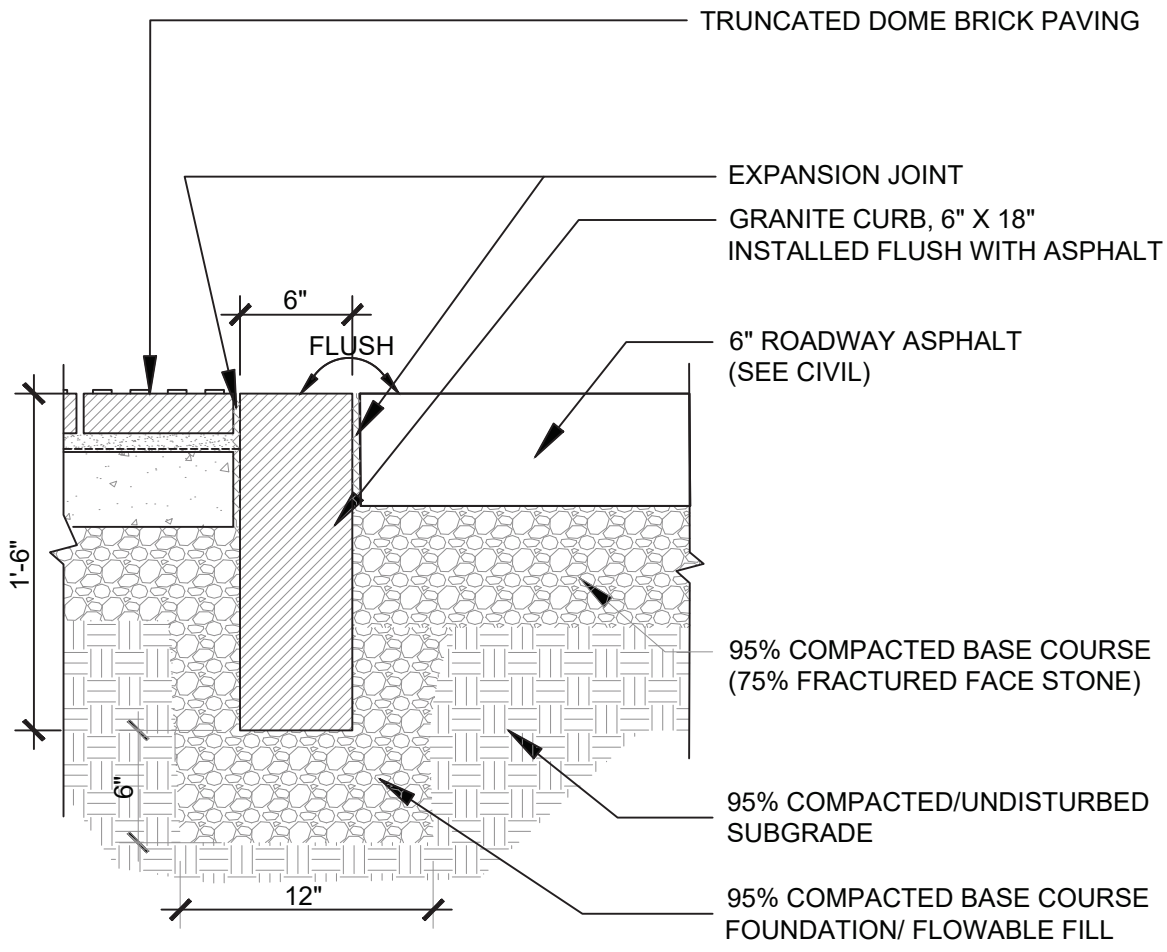

5 GRANITE CURB AT CROSSWALK - SECTION
N.T.S.

	DATE	MAIN STREET SIDEWALK DETAILS	STD. PLAN
	3/2020		230.3-C
	REV.		

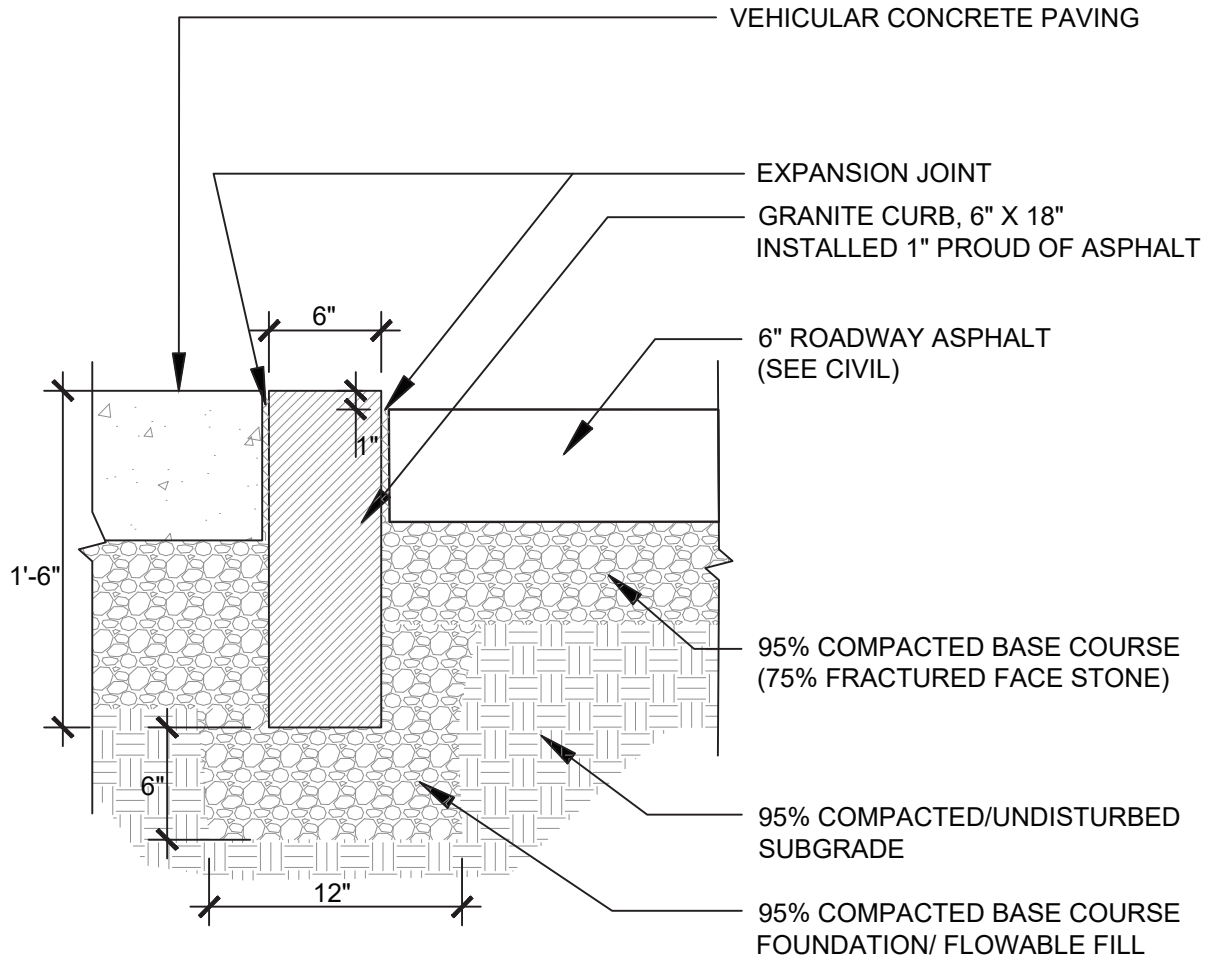

6 GRANITE CURB AT DRIVEWAY - SECTION
N.T.S.

	DATE	MAIN STREET SIDEWALK DETAILS	STD. PLAN
	3/2020		230.3-D
	REV.		

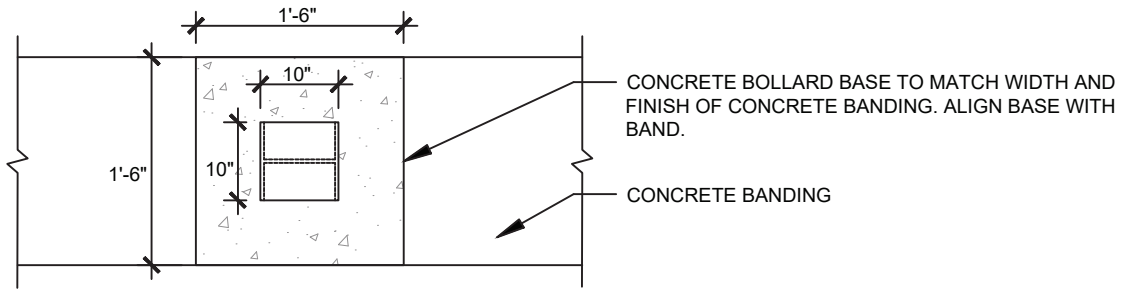

PLAN

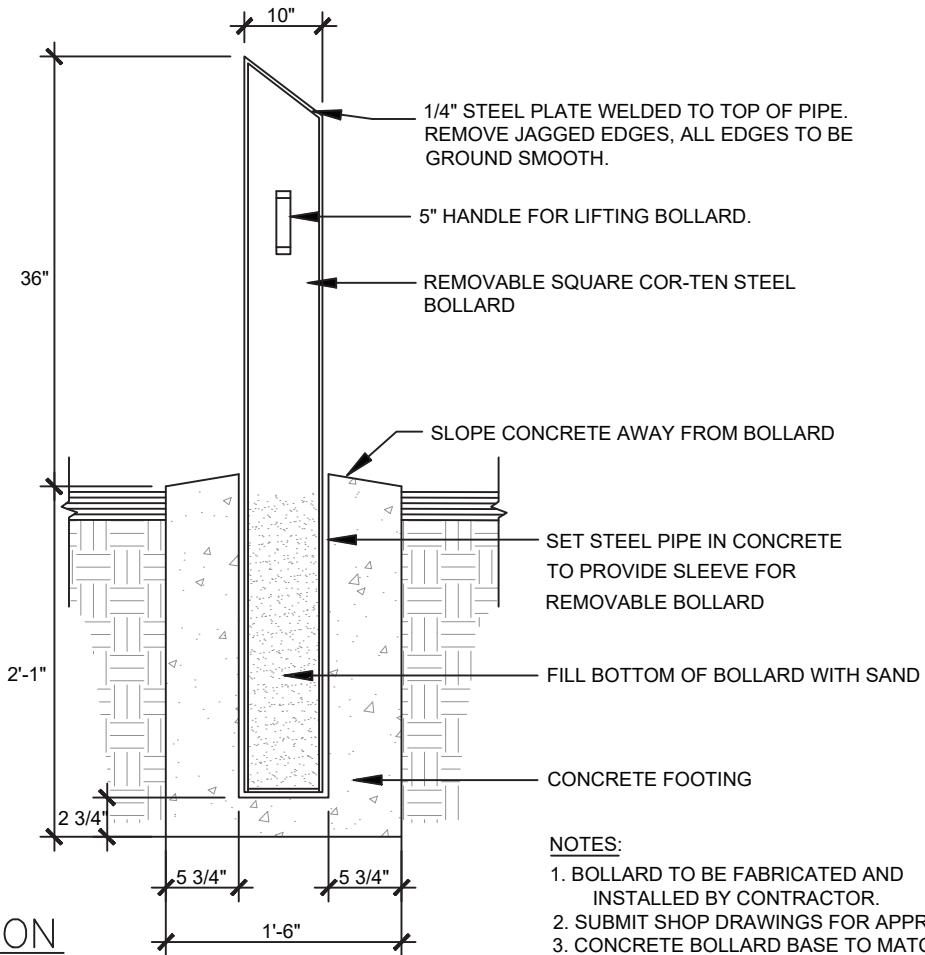

SECTION

NOTES:

1. BOLLARD TO BE FABRICATED AND INSTALLED BY CONTRACTOR.
2. SUBMIT SHOP DRAWINGS FOR APPROVAL.
3. CONCRETE BOLLARD BASE TO MATCH WIDTH AND FINISH OF CONCRETE BANDING. ALIGN BASE WITH BAND.

7 REMOVABLE BOLLARD
N.T.S.

	DATE	MAIN STREET SIDEWALK DETAILS	STD. PLAN
	3/2020		230.3-E
	REV.		

Sidewalk

1. GENERAL

- A. Variance from specified dimensions and slopes must be acceptable to the ENGINEER. System configuration may be changed at ENGINEER's discretion.
- B. Additional requirements are specified in APWA Section 32 16 13.

2. PRODUCTS

- A. Base Course: Untreated base course, APWA Section 32 11 23. Do not use gravel as a base course without ENGINEER's permission.
- B. Expansion Joint Filler: 1/2-inch thick type F1 full depth, APWA Section 32 13 73.
- C. Concrete: Class 4000, APWA Section 03 30 04. If necessary, provide concrete that achieves design strength in less than 7 days. Use caution; however, as concrete crazing (spider cracks) may develop if air temperature exceeds 90 degrees F.
- D. Concrete Curing Agent: Clear membrane forming compound with fugitive dye (Type ID Class A), APWA Section 03 39 00.
- E. Reinforcement: Welded Wire Reinforcement 6x6 minimum W2.9xW2.9 or approved equal.

3. EXECUTION

- A. Base Course Placement: APWA Section 32 05 10. Maximum lift thickness before compaction is 8-inches when using riding equipment or 6-inches when using hand held equipment. Compaction is 95 percent or greater relative to a modified proctor density, APWA Section 31 23 26.
- B. Concrete Placement: APWA Section 03 30 10.
 - 1) Install expansion joints vertical, full depth, with top of filler set flush with concrete surface.
 - 2) Install contraction joints vertical, 1/8-inch wide or 1/4 slab thickness if the slab is greater than 8-inches thick. Maximum length to width ratio for non-square panels is 1.5 to 1. Maximum panel length (in feet) is 1.5 times the slab thickness (in inches).
 - 3) Provide 1/2-inch radius edges. Apply a broom finish. Apply a curing agent.
- C. Reinforcement Placement: Ensure reinforcement is placed with minimum 2" concrete cover.

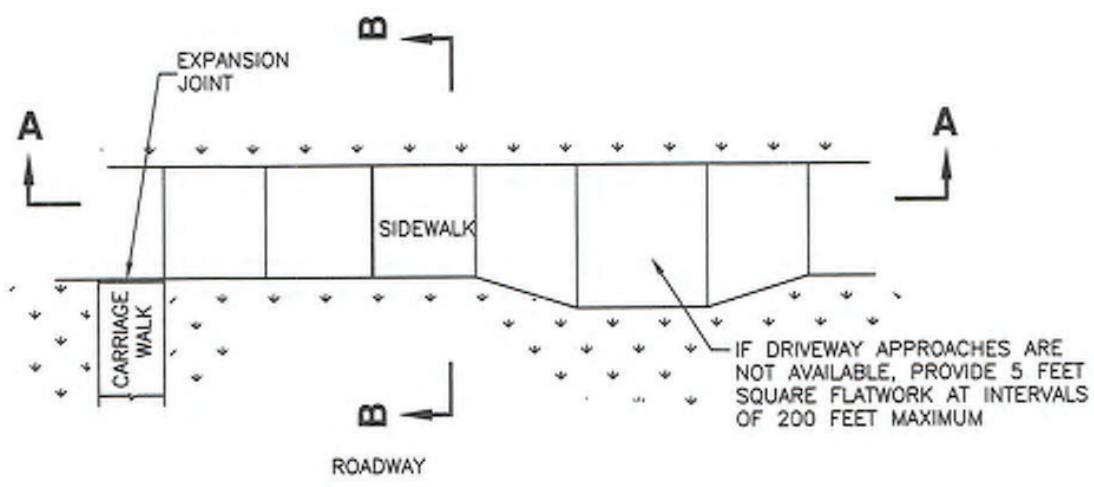

PLAN

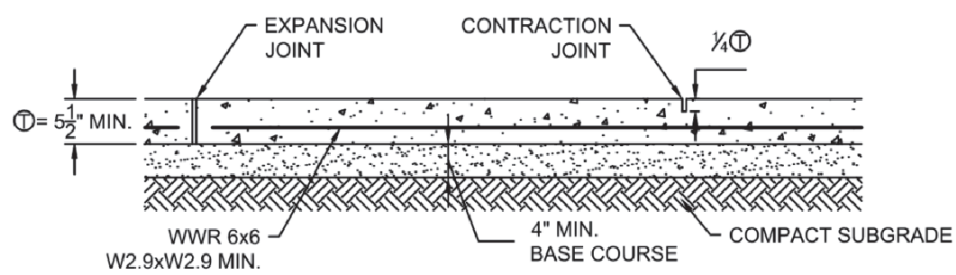

SECTION A-A

STREET TYPE	Ⓣ
RESIDENTIAL	6"
OTHER	
REPLACING EXISTING SIDEWALK	MATCH EXISTING (6" MIN.)

SEE DRIVEWAY APPROACH PLANS FOR SIDEWALK THICKNESS AT DRIVEWAYS

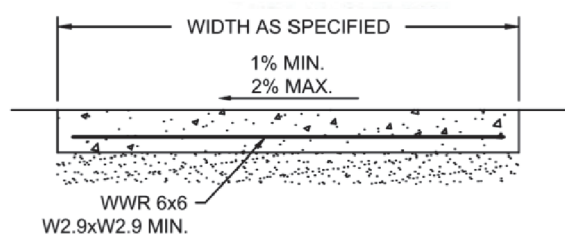

SECTION B-B

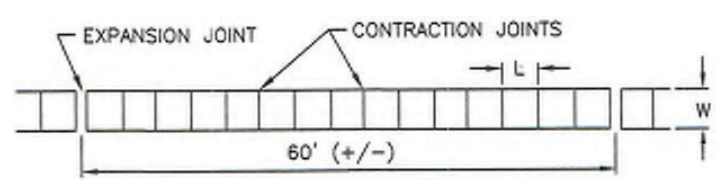

$$L_{MIN} = W$$

$$L_{MAX} \text{ (in feet)} = 2.5 \times \text{Ⓣ} \text{ (in inches)}$$

OR

$$= 15 \text{ FEET MAX}$$

SIDEWALK JOINT DETAIL



PARK CITY MUNICIPAL CORPORATION
ENGINEERING

DATE	01/24/24
REV.	

SIDEWALK

STD. PLAN	
	231

NOTE: SUBJECT TO APPROVAL OF PUBLIC WORKS DIRECTOR, STREET SIGNS AND TRAFFIC CONTROL SIGNS MAY BE MOUNTED ON STREET LIGHT POLE.

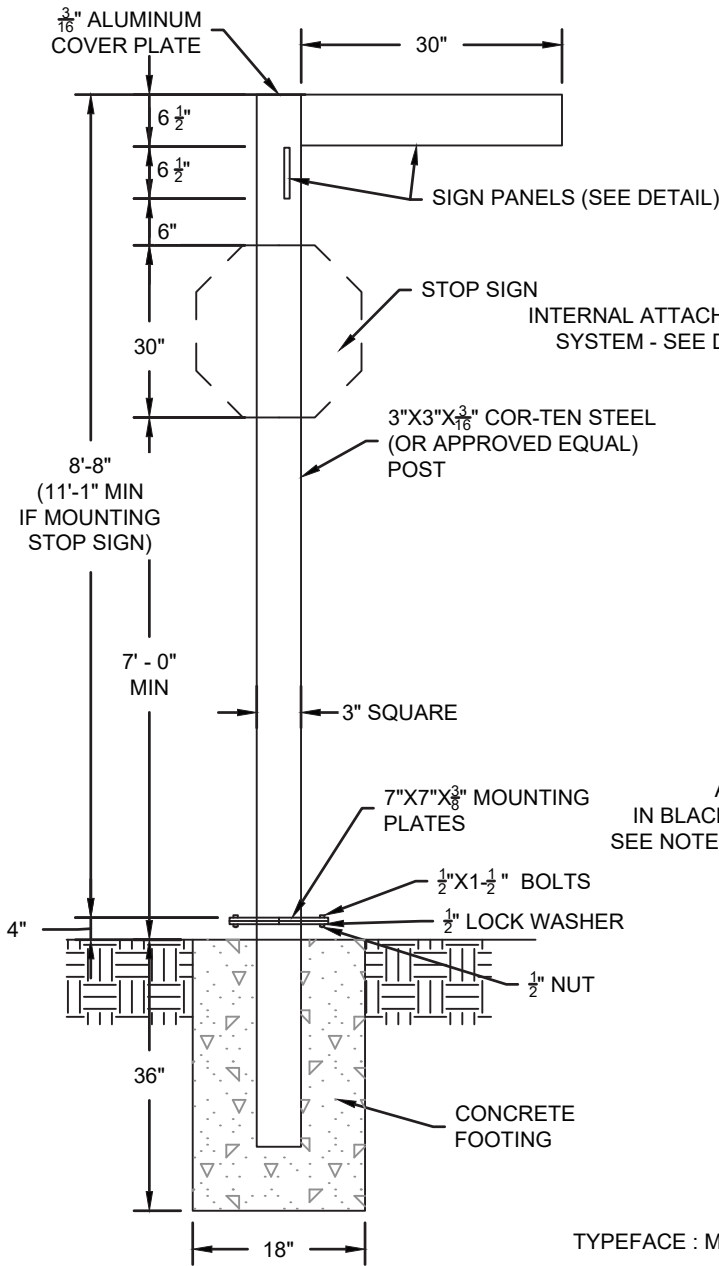

STREET SIGN ELEVATION

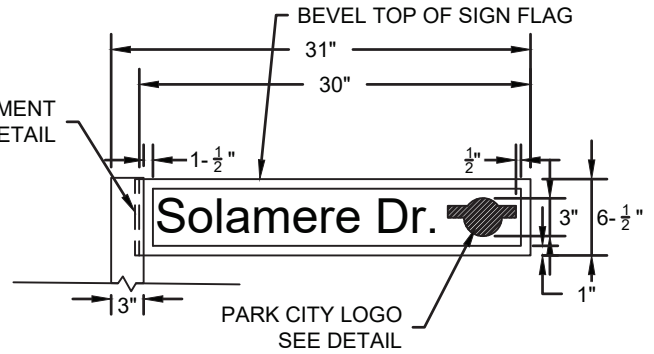

STREET SIGN FACE DETAIL

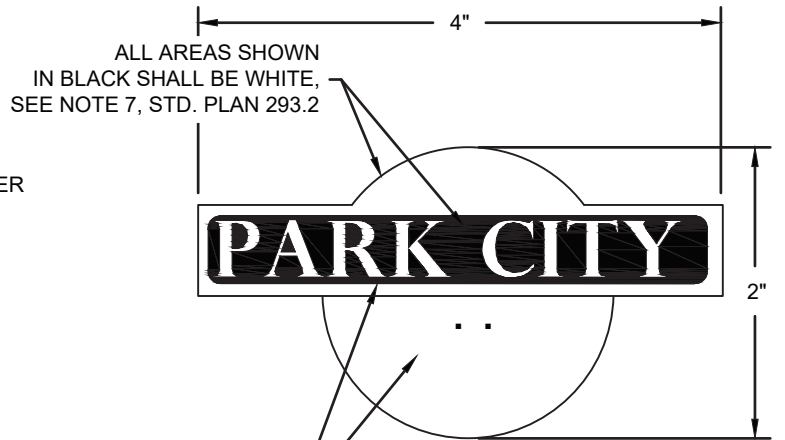

PARK CITY LOGO DETAIL

TYPEFACE : MODERN NO. 20

ALL AREAS SHOWN IN BLACK SHALL BE WHITE, SEE NOTE 7, STD. PLAN 293.2

NOT TO SCALE



DATE	STREET SIGN DETAILS	STD. PLAN
3/2020		293.1
REV.		
8/2020		

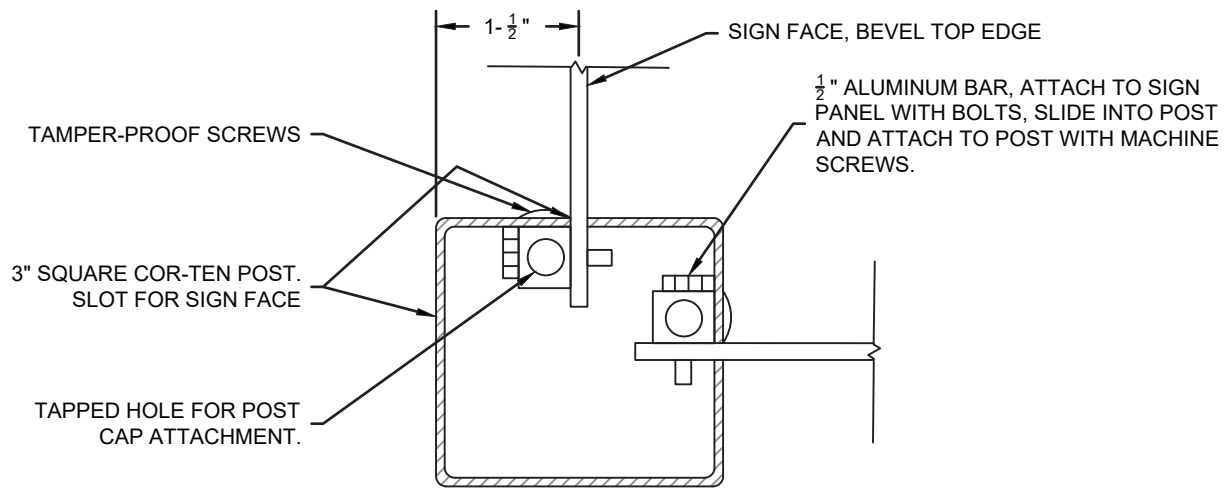

STREET ATTACHMENT SECTION

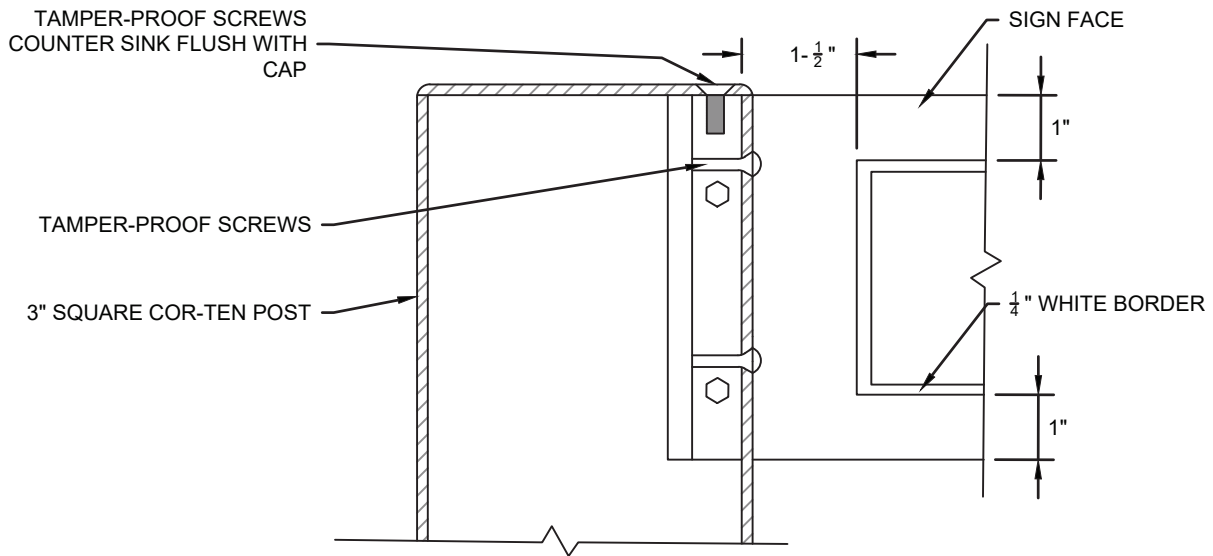

STREET ATTACHMENT ELEVATION

1. 3"X3"X $\frac{3}{16}$ " COR-TEN STEEL POST.
2. 3"X3"X $\frac{3}{16}$ " COR-TEN STEEL BASE EMBEDDED IN CONCRETE.
3. $\frac{1}{4}$ " THICK SIGN PLATES ELECTRO-CHEMICALLY PLATED TO PRODUCE AN ANODIZED HARD COAT FINISH. MOUNT SIGN PLATES IN THE CENTER AND AT RIGHT ANGLES TO THE POST.
4. THE ATTACHMENT OF THE SIGN PANELS TO THE POST SHALL BE VANDAL-PROOF.
5. ALL FASTENERS SHALL BE DARK BRONZE TO MATCH THE SIGN FACE.
6. LETTERING SHALL BE 3" HELVETICA MEDIUM UPPER AND LOWER CASE, REFLECTIVE WHITE SCOTCH-LITE APPLIED TO FACE AND BAKED ON.
7. THE BORDER AND LOGO SHALL BE APPLIED BY SCREEN PROCESS AND SHALL BE WHITE ENAMEL.

NOT TO SCALE

	DATE	STREET SIGN DETAILS	STD. PLAN
	3/2020		293.2
	REV.		

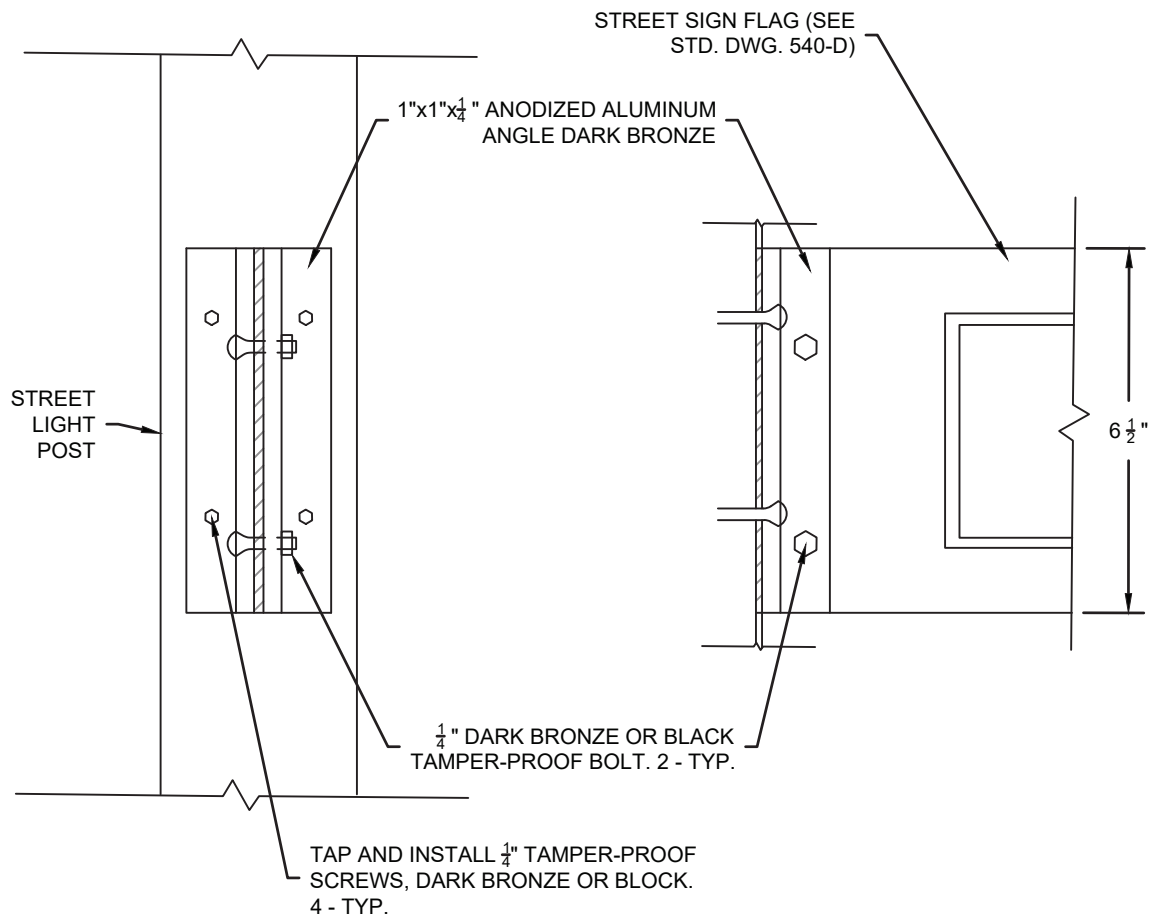

NOT TO SCALE



DATE

3/2020

REV.

MOUNTING DETAIL FOR SIGN ON LIGHT POLE

STD. PLAN

294

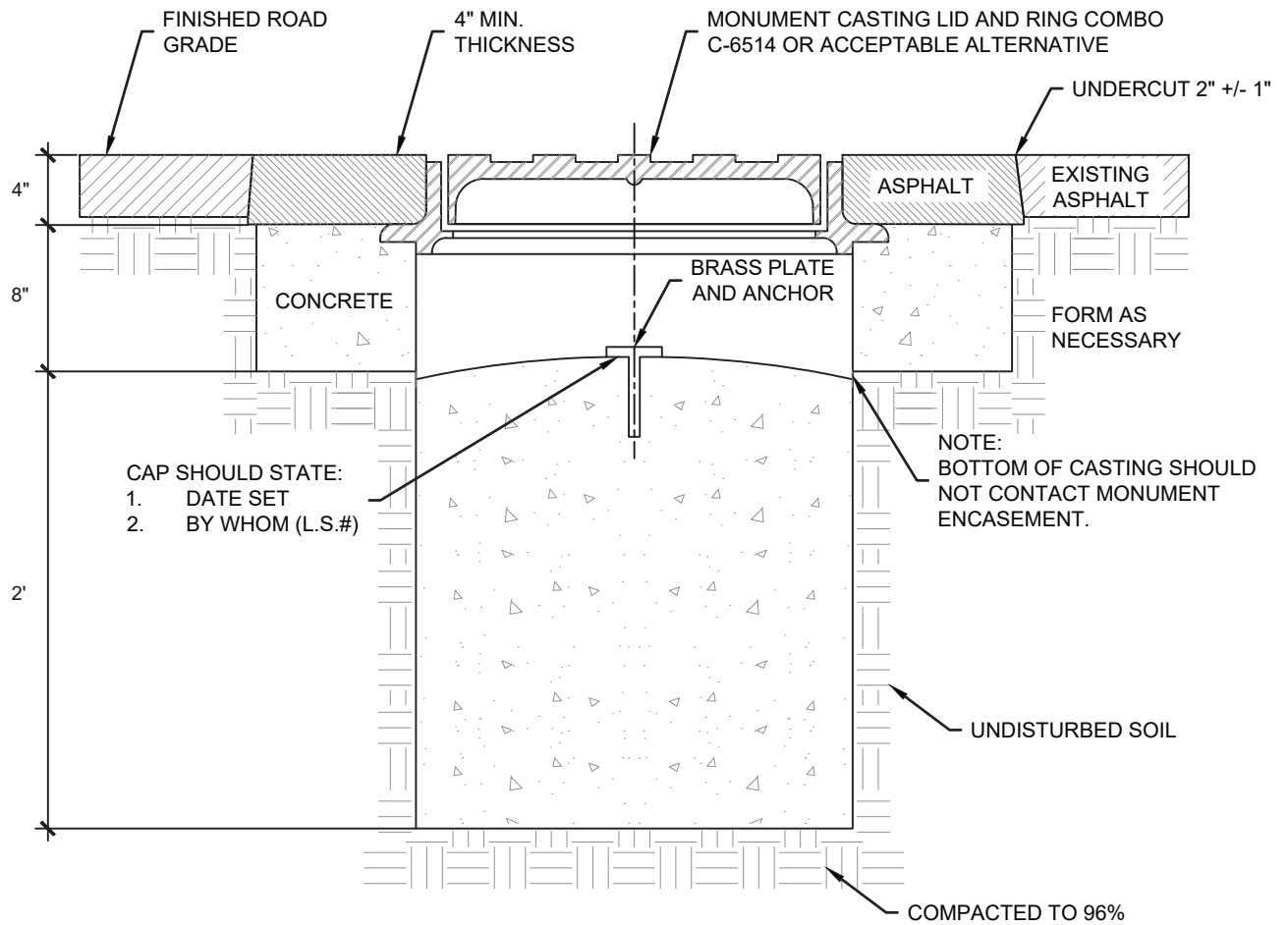

NOTE:

1. CASTINGS, CAST IRON PIPE, BRASS PLATE AND ANCHOR TO BE FURNISHED AND INSTALLED BY THE DEVELOPER UNDER CITY SUPERVISION.



DATE

8/2020

REV.

STANDARD CITY STREET
MONUMENT

STD. PLAN

295

296.01 Street Lighting Product Specifications

PART 1 GENERAL

1.1 SECTION INCLUDES

- A. K828 Moderne Sr. – LED or approved equal product specifications.

PART 2 PRODUCTS

2.1 PRODUCT SPECIFICATIONS

- A. LED ENGINE
 - 1. Light engine shall include an array of 60 or 84 solid state Cree X-Series high power LEDs (light emitting diodes). The emitters shall be mounted to a metal core circuit board using SMT technology. The LEDs and circuit boards shall then be mounted to a high-performance heat sink which is vented to the outside ambient air to provide dynamic airflow for cooling the system.
- B. OPTICS
 - 1. External light control shall consist of high precision refractive lenses mounted above the LED emitter arrays in such a way to achieve optimum uplight control. The lenses shall also control horizontal light distribution so that Type II, III, IV or V IESNA distribution patterns are achieved.
- C. LENS
 - 1. Lens options include: sag glass lens, shallow glass lens, or rippled acrylic deep dish lens. The glass lens shall be made of #9000 clear borosilicate glass (fully annealed). It shall maintain a minimum thickness of 0.3". The deep dish globe shall be molded of rippled acrylic Acrylite Plus Acrylic Polymer, or equivalent, having a minimum thickness of 0.09". The lens is secured by means of a cast A319 aluminum holding ring that is sealed to provide an IP66 Ingress rating. Additionally, a continuous circular gasket rated for 270°F must hold the lens into place within the cast ring assembly and assist in sealing the fixture.
- D. DECORATIVE BODY
 - 1. The luminaire shall consist of a heavy Grade A319 cast aluminum housing that acts as the enclosure for the engine and is of adequate thickness to give structural rigidity. The engine must be affixed to the inside of the housing with stainless steel screws.
 - 2. The bottom decorative portion of the fixture is comprised of a one-piece spun aluminum alloy with a minimum thickness of 0.09". The spinning is permanently affixed to the cast housing with the use of stainless steel hardware.
- E. PLUMBIZER
 - 1. Mounting options include the KPL10, KPL11, KPL20, KPL21, KPL30, KPL31, KPL40, or approved equals.
- F. DRIVER
 - 1. The LED universal dimmable driver will be class 2 and capable of 120 - 277V or 347 - 480V input voltage, greater than 0.9 power factor, less than 20% total harmonic distortion. The case temperature of the driver can range from -40°C to 70°C. Each LED system comes with a standard surge protection designed to withstand up to 20kV/10kA of transient line surge as per IEEE C62.41.2 C High. An in-line ferrite choke is utilized to provide protection against EFT's. The driver assembly will be mounted on a heavy duty fabricated aluminum bracket to allow complete tool-less maintenance. Dimming capable using 1-10vdc (10% to 100%), 10v PWM, or resistance.
- G. PHOTOMETRICS
 - 1. Fixtures are tested to IESNA LM79 specifications. These reports are typically available upon request.

- H. CHROMATICITY
 - 1. High output LED come standard at 3000K & 4000K (+/- 300K) with a minimum nominal 70 CRI.
- I. LUMEN MAINTENANCE
 - 1. Reported (TM21) and Calculated (L70) reports are available upon request with a minimum calculated value of 100,000 hrs.
- J. WIRING
 - 1. All internal wiring and connections shall be completed so that it will be necessary only to attach the incoming supply connectors to Mate-N-Lok connectors or to a terminal block. Mate-N-Lok shall be certified for 600V operation.
 - 2. Internal wire connectors shall be crimp connector only and rated at 1000V and 150°C. All wiring to be CSA certified and/or UL listed, type SFF-2, SEWF-2, or SEW-2
 - 3. No. 14 gauge, 150°C, 600V, and color coded for the required voltage.
- K. THERMALS
 - 1. Fixtures tested to DOE sanctioned standards to determine the maximum in-situ solder-point or junction-point temperatures of the LED emitters. This report is typically available upon request.
- L. FINISH
 - 1. Housing is finished with a 13 step KingCoat™ SuperDurable poly- ester TGIC powder coat. Standard colors include strobe white, brown metal, marina blue, gate gray, Chicago bronze, standard gold, standard black, federal green and rain forest.
- M. MISCELLANEOUS
 - 1. All exterior hardware and fasteners, wholly or partly exposed, shall be stainless steel alloy. All internal fasteners are stainless steel or zinc coated steel. All remaining internal hardware is stainless steel, aluminum alloy, or zinc coated steel.
- N. WARRANTY
 - 1. Luminaire comes with a 7-year limited warranty
- O. CERTIFICATION
 - 1. CSA US Listed
 - 2. Suitable for wet locations ISO 9001
 - 3. IP66
 - 4. ARRA Compliant
 - 5. LM79 / LM80 Compliant
- P. DRIVER INFO
 - 1. >0.9 Power Factor
 - 2. <20% Total Harmonic Distortion 120 - 277V & 347 - 480V
 - 3. -40°C Min. Case Temperature 70°C Max. Case Temperature Surge Protection: ANSI C136.2 extreme level 20kV/10kA Dimming Capable: 1-10vdc
- Q. EPA
 - 1. Flat Lens: 0.97 sq. ft.
 - 2. Sag Lens: 1.02 sq. ft.
 - 3. Shallow Lens: 1.20 sq. ft.
 - 4. Deep Dish Acrylic: 1.52 sq. ft.
 - 5. Deep Dish Glass: 1.52 sq. ft.
- R. FIXTURE WEIGHT
 - 1. Flat Lens: 43 lbs
 - 2. Sag Lens: 51 lbs
 - 3. Shallow Lens: 53 lbs
 - 4. Deep Dish Acrylic: 49 lbs
 - 5. Deep Dish Glass: 49 lbs

2.2 FIXTURE OPTIONS

A. LENS OPTIONS

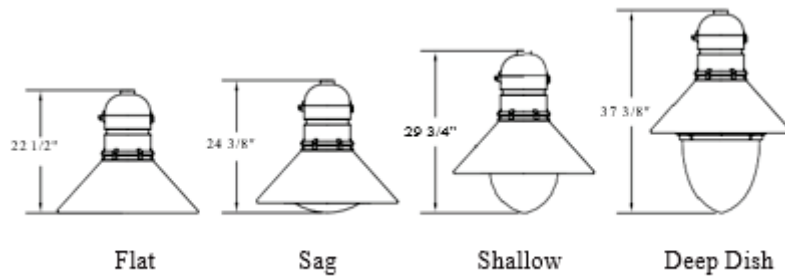

B. 1. PLUMBIZER/ MOUNTINGS OPTIONS

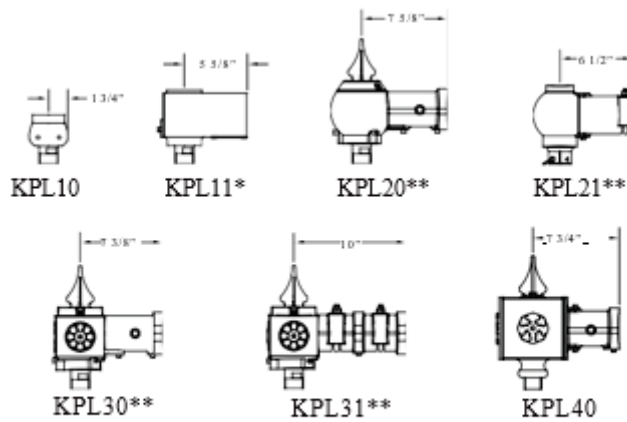

*Available with PR.7

**Available with PR.7 or finial

1.

PART 3 EXECUTION

3.1 HOW TO ORDER

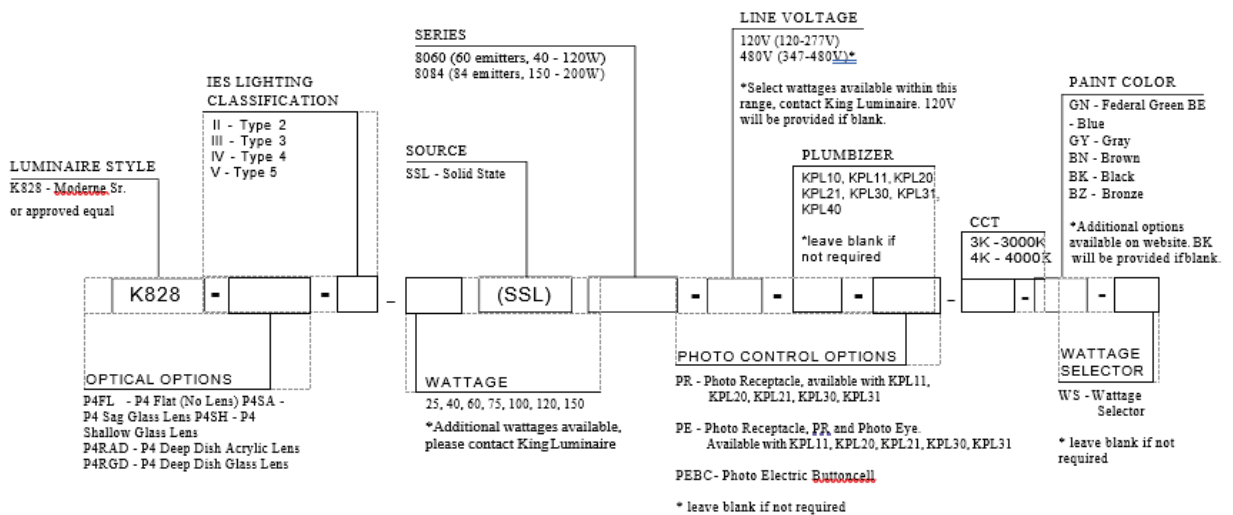

A.

KING LUMINAIRE K828 LED FIXTURE PROVIDED
BY MOUNTAIN STATES LIGHTING
PART #: K828-P4FL-III-100W(SSL)-8060-120V-2700K
BK-WATTAGE SWITCH

RD8645 BK TWIST LOCK
PHOTOCELL (UDOT SPEC)

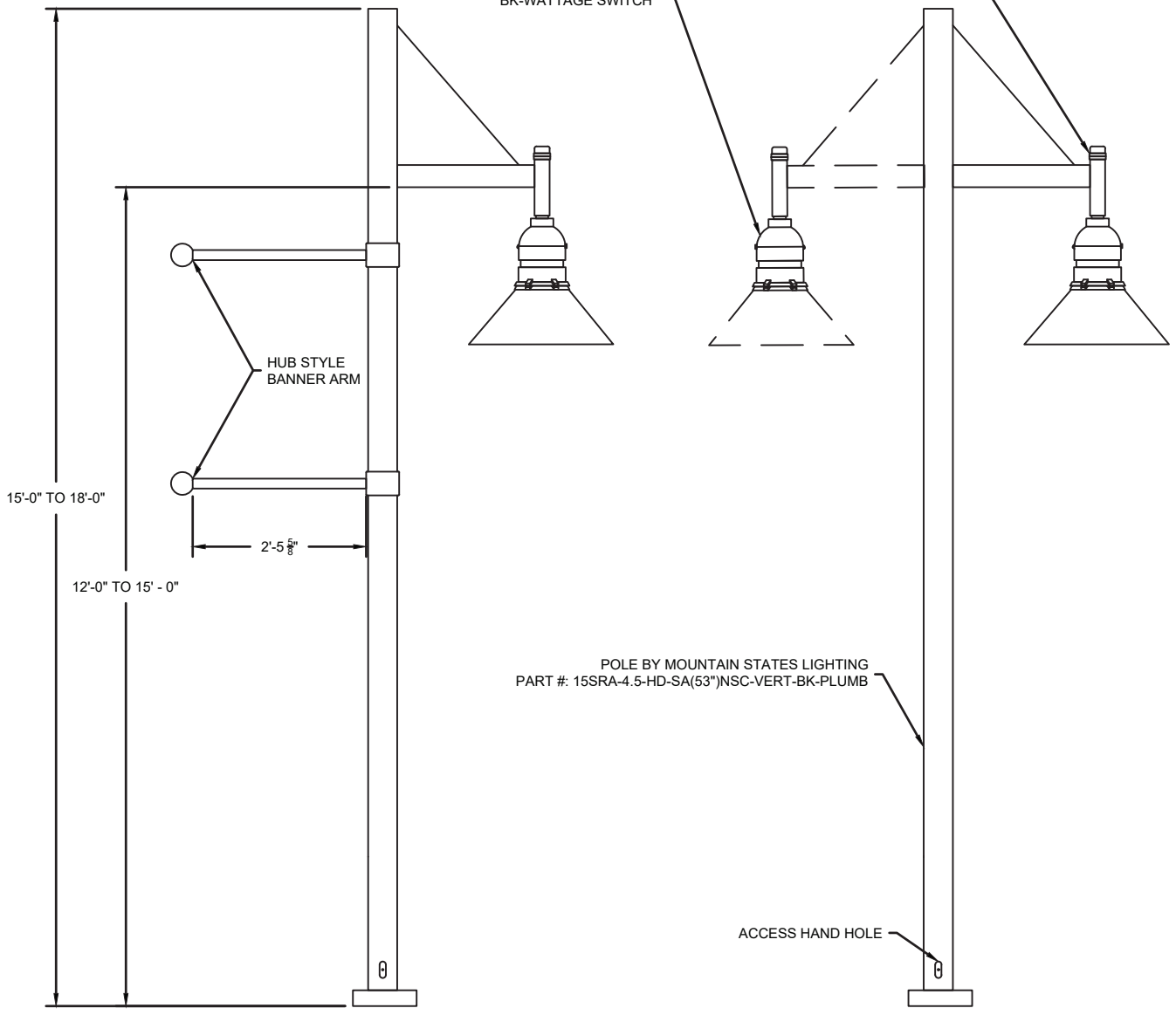

POLE BY MOUNTAIN STATES LIGHTING
PART #: 15SRA-4.5-HD-SA(53")NSC-VERT-BK-PLUMB

ACCESS HAND HOLE

LIGHT POLE ELEVATION

NOT TO SCALE

	DATE	STREET LIGHTING	STD. PLAN
	11/2020		296.1
	REV.		

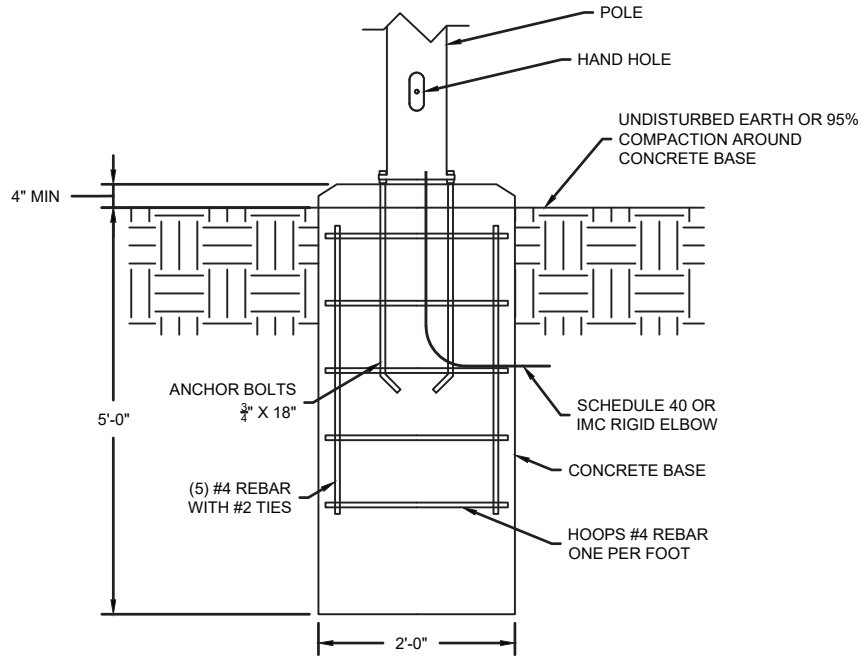

CONCRETE BASE DETAIL

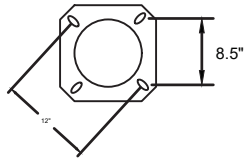

ANCHOR BASE DETAIL

12" BOLT CIRCLE
ANCHOR BOLTS: $\frac{3}{4}$ " X 18" GALV

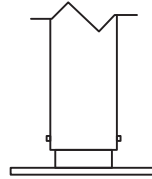

POLE BASE DETAIL

ALUMINUM POLE IS COMPRESSION FIT
OVER AN 18" GALVANIZED STEEL STUMP
AND SECURED WITH FOUR FASTENERS

NOTES:

1. IF DEPTH CANNOT BE MET, MASS MUST BE EQUIVALENT TO MASS SHOWN.
2. HIGHWAY LIGHTING SYSTEM REQ'D.
3. CONTACT ROCKY MOUNTAIN POWER, MINIMUM OF 30 WORKING DAYS BEFORE POWER IS REQ'D, TO COORDINATE POWER SOURCE LOCATION AND CONNECTION.
4. PROVIDE MIN OF 3 FT OF CABLE SLACK IN EVERY JUNCTION BOX.
5. LIGHT POLES AND LIGHT FIXTURES SHALL CONFORM TO PARK CITY REQUIREMENTS AND BE APPROVED BY THE CITY ENGINEER.
6. EACH STREET LIGHT SHALL HAVE A JUNCTION BOX WITH FUSE.
7. MARK JUNCTION BOX COVERS WITH "STREET LIGHTING".
8. LIGHT POLES SHALL HAVE BASKET HANGERS.

NOT TO SCALE



DATE	11/2020
REV.	

STREET LIGHT BASE DETAILS

STD. PLAN	
	296.2

DIVISION 300 STORM DRAIN

SINGLE GRADE

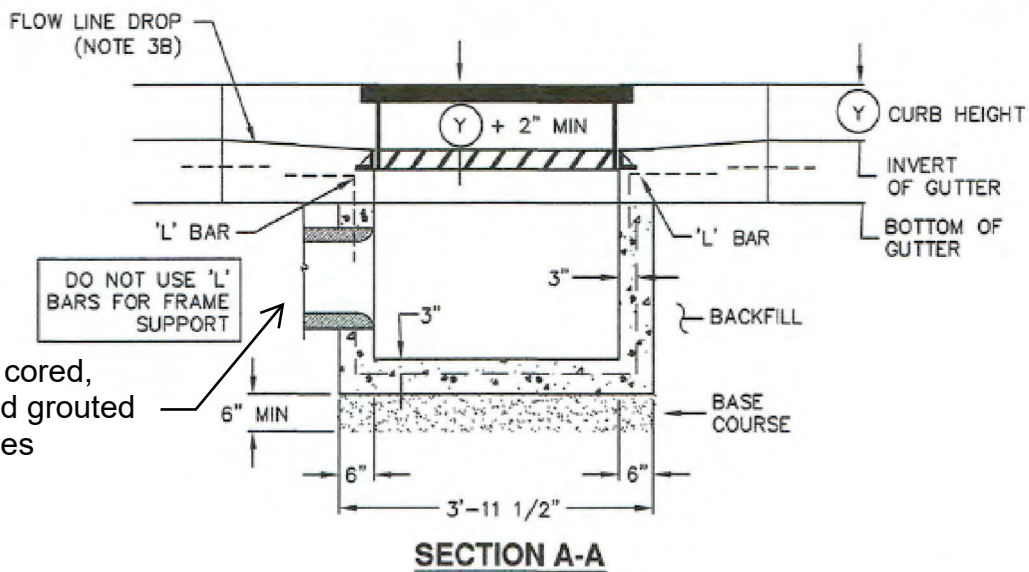
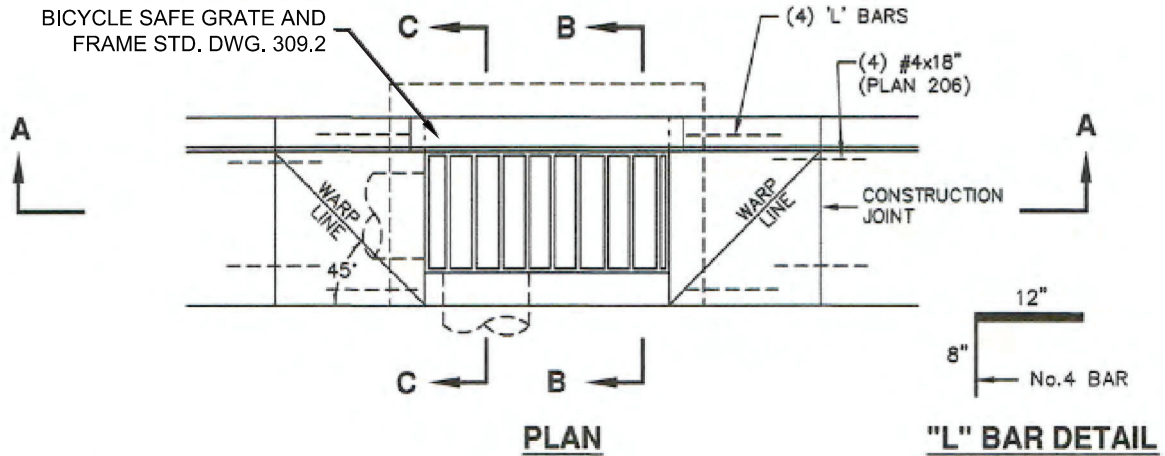

Pipes to be cored, collared, and grouted into the boxes

DO NOT USE 'L' BARS FOR FRAME SUPPORT

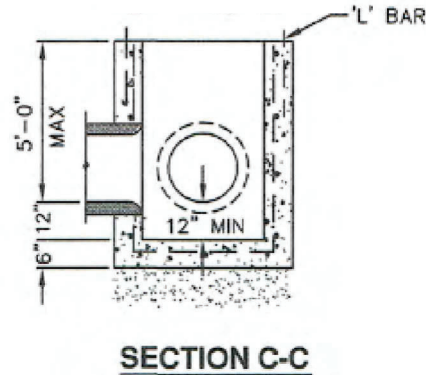
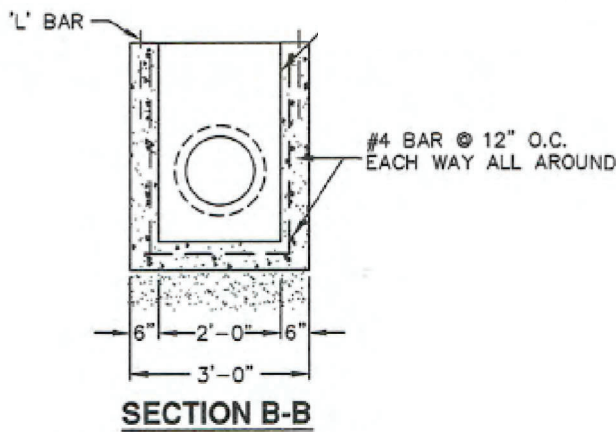

	DATE	SINGLE GRADE CATCH BASIN	STD. PLAN
	3/2020		315.1
	REV.		

DOUBLE GRATE

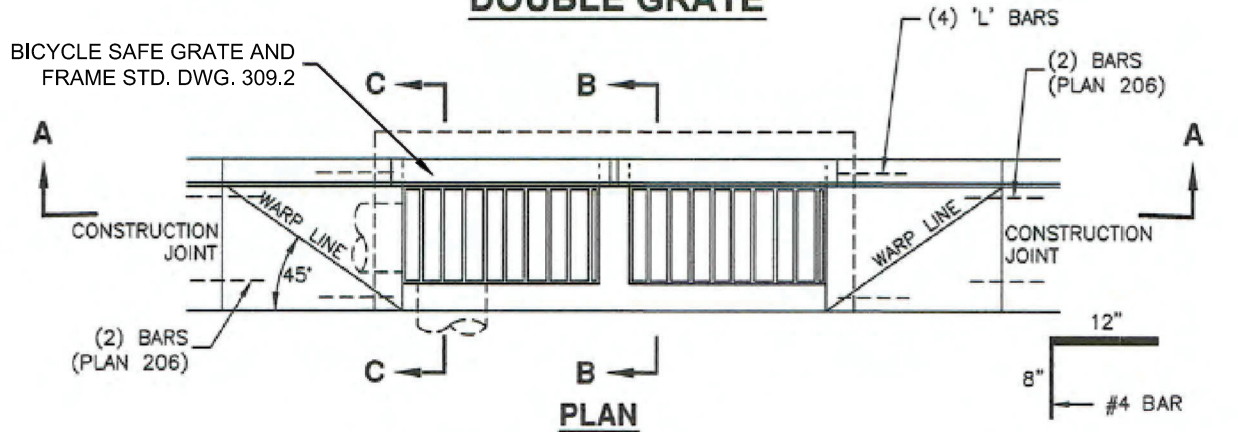

"L" BAR DETAIL

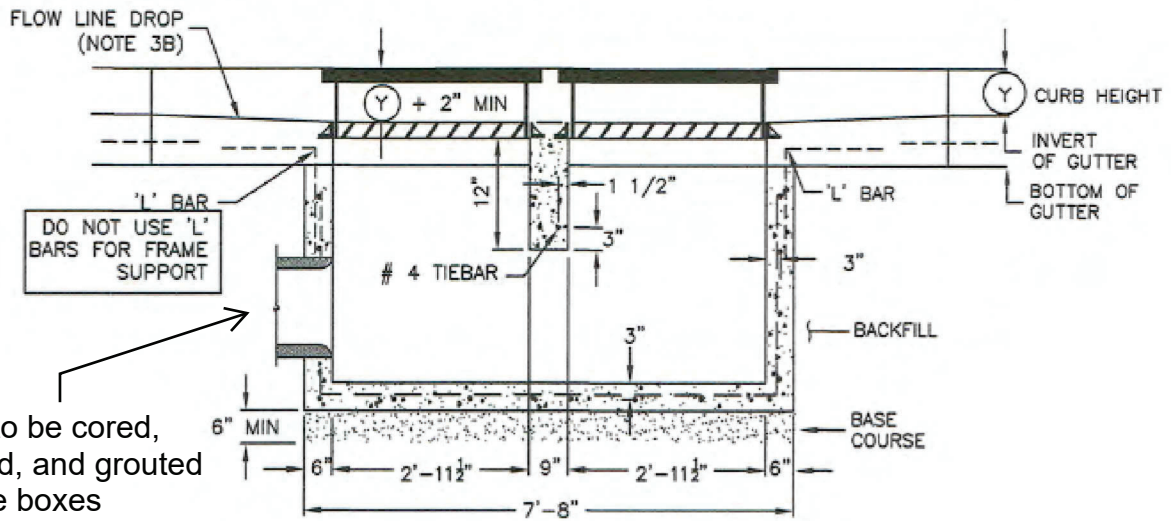

SECTION A-A

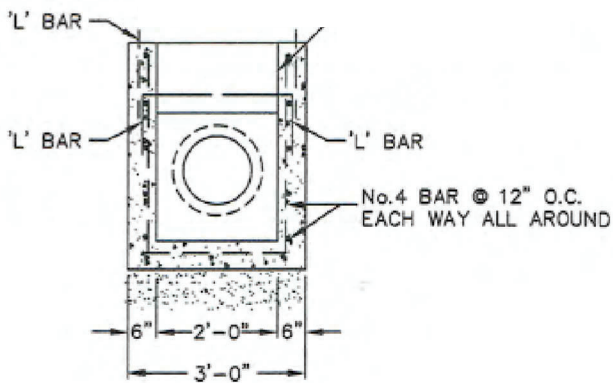

SECTION B-B

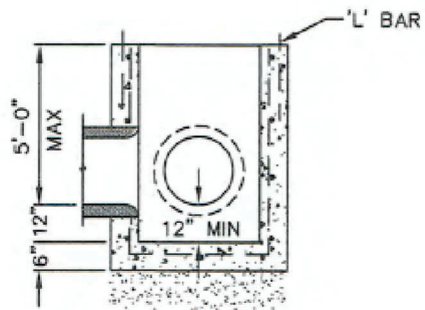

SECTION C-C



DATE
3/2020
REV.

DOUBLE GRATE CATCH BASIN

STD. PLAN
315.2

PIPE ZONE BACKFILL

1. GENERAL

A. Install the pipe in the center of the trench.

2. PRODUCTS

- A. Backfill: Common fill, APWA Section 31 05 13. Maximum particle size 2-inches.
- B. Concrete: APWA Section 03 30 04.
- C. Flowable Fill: Target is 60 psi in 28 days with 90 psi maximum in 28 days, APWA Section 31 05 15. It must flow easily requiring no vibration for consolidation.
- D. Stabilization-Separation Geotextile: Moderate or high at CONTRACTOR'S choice, APWA Section 31 05 19.

3. EXECUTION

- A. Excavate the Pipe Zone: Width is measured at the pipe spring line and includes any necessary sheathing. Provide width recommended by pipe manufacturer. Follow manufacturer's recommendations when using trench boxes.
- B. Foundation Stabilization: Obtain ENGINEER'S permission before installing common fill. Vibrate to stabilize. Installation of stabilization-separation geotextile will be required to separate backfill material and native subgrade materials if common fill cannot provide a working surface or prevent soils migration.
- C. Bedding: Follow APWA Section 33 05 20 requirements and the following provisions.
 - 1) Furnish 3/4" minus washed rock for plastic pipe and 1" minus washed rock for concrete pipe material unless specified otherwise by pipe manufacturer.
 - 2) Maximum lift thickness is 8-inches.
 - 3) Bedding immediately under the pipe should not be compacted, but loosely placed.
 - 4) Compaction is 95 percent or greater relative to a modified proctor density, APWA Section 31 23 26.
- D. Pipe Zone: DO NOT USE sewer rock, pea gravel, or recycled RAP aggregate in the pipe zone. Water jetting is NOT allowed.
 - 1) Maximum lift thickness is 8-inches before compaction. Compaction is 95 percent or greater relative to a modified proctor density, APWA Section 31 23 26 unless pipe manufacturer requires more stringent installation.
 - 2) Submission of quality control compaction test result data developed for the haunch zone may be requested by ENGINEER at any time. CONTRACTOR is to provide results of tests immediately upon request.
- E. Flowable Fill (when required and if allowed by pipe manufacturer):
 - 1) Place the controlled low strength material, APWA Section 31 05 15.
 - 2) Prevent pipe flotation by installing in lifts and providing pipe restraints as required by pipe manufacturer.
 - 3) Reset pipe to line and grade if pipe "floats" out of position.

 PARK CITY MUNICIPAL CORPORATION ENGINEERING	DATE	Pipe Zone Backfill	STD. PLAN
	6/2026		
	REV.		382

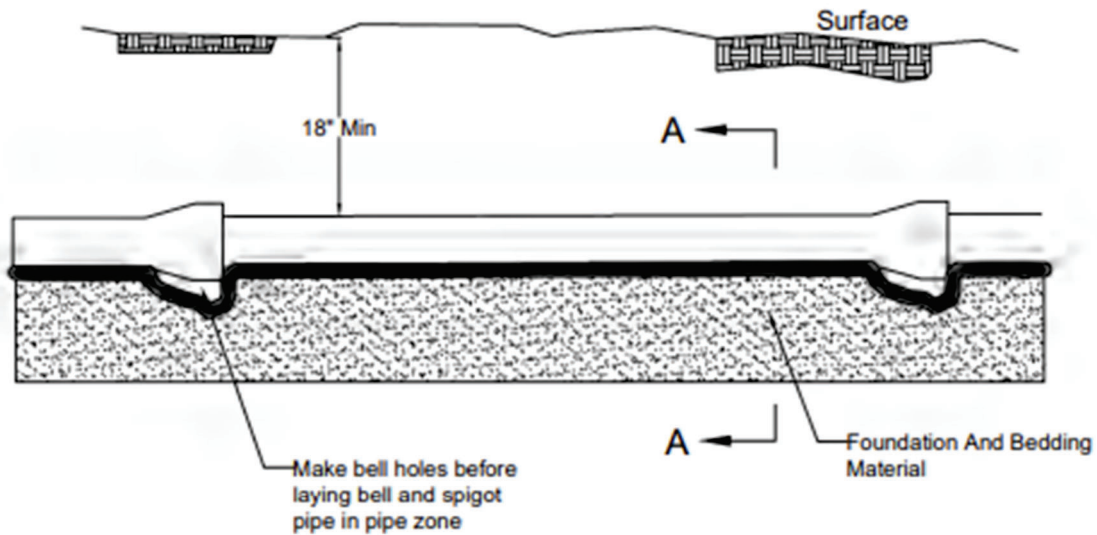

Elevation View

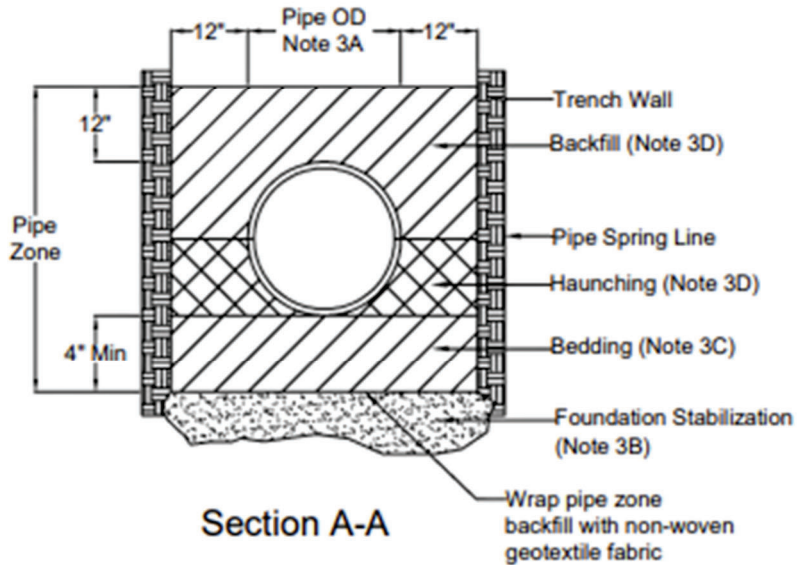

Section A-A

Installation

Concrete Pipe: Follow ASTM C 1479

*Standard Practice For Installation Of Precast Concrete Sewer, Storm Drain, And Culvert Pipe Using Standard Installations

Plastic Pipe: Follow ASTM D 2321

*Standard Practice For Underground Installation Of Thermoplastic Pipe For Sewers And Other Gravity-flow Applications

Corrugated Metal Pipe: Follow ASTM A 798

*Standard Practice For Installing Factory-made Corrugated Steel Pipe For Sewers And Other Applications



PARK CITY MUNICIPAL CORPORATION
ENGINEERING

DATE

6/2026

REV.

Pipe Zone Backfill

STD. PLAN

382

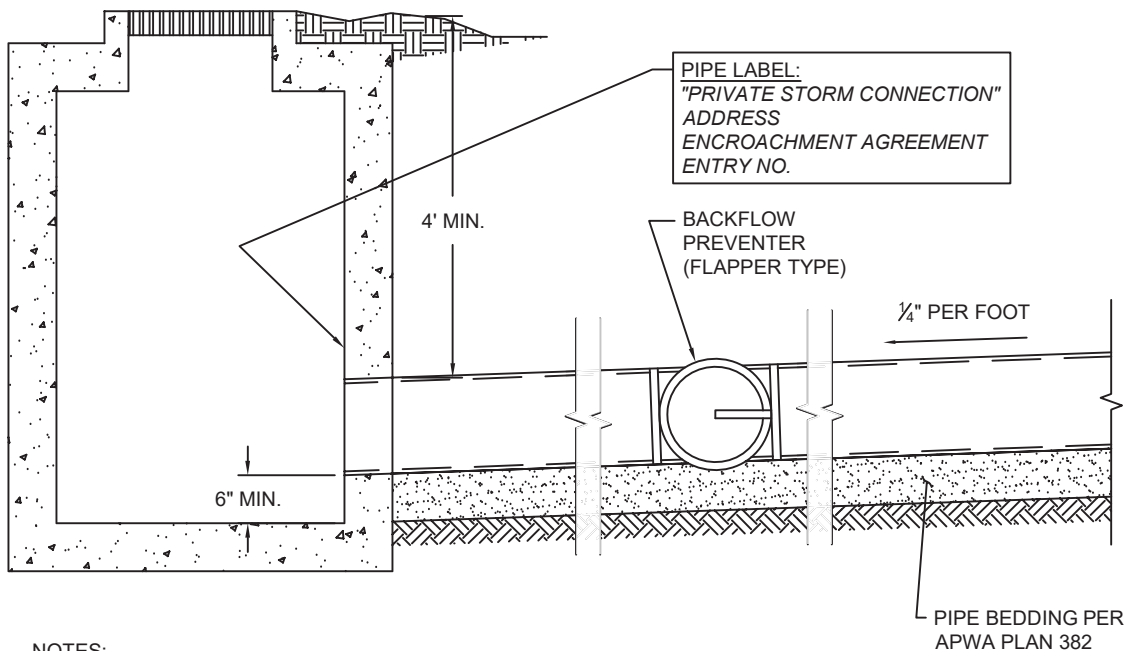

NOTES:

1. THE CONNECTION TO THE STORM SYSTEM SHALL BE WITNESSED BY INSPECTOR.
2. THE SLOPE OF THE SERVICE SHOULD BE 1/4" PER FOOT (IT SHALL BE NO LESS THAN 1/8").
3. THE LATERAL SHALL HAVE A MINIMUM OF 4' OF COVER TO THE FINISHED GRADE WHERE THE CONNECTION IS MADE TO THE STORM SYSTEM.
4. PIPE SHALL BE CORED AND GROUTED INTO THE CATCH BASIN WITH GROUT PER APWA SPEC. SECTION 03 61 00.
5. THE APPLICANT SHALL RECORD AN ENCROACHMENT AGREEMENT WITH THE CITY. THE CITY IS NOT RESPONSIBLE FOR ANY DAMAGE TO THE PRIVATE PROPERTY RESULTING FROM THIS CONNECTION TO THE STORM SYSTEM.



PARK CITY MUNICIPAL CORPORATION
ENGINEERING

DATE

01/24/24

REV.

**PRIVATE CONNECTION TO
PUBLIC STORM SYSTEM**

STD. PLAN

399

DIVISION 400 UNUSED

DIVISION 500 WATER

WATER STANDARD PLANS

2025

PREFACE

These standard plans incorporate current Water regulations and City water system operation, maintenance, and asset management considerations.

The plan numbering structure of this document follows the same basic structure as the APWA Standard Plans, however, there are some differences. Following is an explanation of the structure of this document:

1. Part 5 – Water Systems. Standard Plan divisions for Water system related details are:
 - Preface, Updates, and Table of Contents
 - Water Notes
 - Fire Hydrants
 - Water Meters
 - Corrosion Protection Systems
 - Piping
 - Thrust Blocks
 - Valves
 - Trenching
 - General
 - Water System Field Observation Guidelines

2. Numbering – A plan number having a suffix of “S” identifies that the plan contains index, legend, detail specific notes, and acceptable manufacturer and parts numbers related to the standard plan.

This document is intended to be altered periodically to ensure that the most current Park City Standards are available for public use. This document will be revised and published on the City’s web site as updates are approved and adopted.

THE FOLLOWING IS A SUMMARY OF CHANGES MADE TO DRAWINGS

2025

500: Updated notification requirements. Added record drawing and geospatial data requirements. Updated water interruption requirements. Updated backflow and booster pump information.

520: Updated water meter sizing calculations. Updated water main tapping requirements.

523 S: Added double check backflow assembly. Updated approved manufacturers and models.

526 S: Added double check backflow assembly. Updated approved manufacturers and models.

527 & 527 S: Added swing check backflow assembly.

528 & 528 S: Added swing check backflow assembly. Updated backflow information.

547-B: Added DDW exception requirement. Removed looped water line.

572: Added hoop steel size

573-E.3: Updated backpanel requirements.

FIELD OBSERVATION GUIDELINES: Updated AWWA Standards.

*All drawing updates are shown with updated date and revision in title block.

GENERAL WATER NOTES

1. THE FOLLOWING DOCUMENTS ARE INCORPORATED INTO THESE CONTRACT DOCUMENTS BY REFERENCE:
 - a. *PARK CITY DESIGN STANDARDS, CONSTRUCTION SPECIFICATIONS, AND STANDARD DETAILS*
 - b. AMERICAN WATER WORKS ASSOCIATION STANDARDS (AWWA)
 - c. UTAH DEPARTMENT OF ENVIRONMENTAL QUALITY, DIVISION OF DRINKING WATER (DDW), R309-550 FACILITY DESIGN AND OPERATION: TRANSMISSION AND DISTRIBUTION PIPELINES
 - d. INTERNATIONAL PLUMBING CODE
2. ALL PIPE, JOINTS, FITTINGS, VALVES, AND FIRE HYDRANTS SHALL CONFORM TO ANSI/NSF STANDARD 61 AND APPLICABLE SECTIONS OF AWWA STANDARDS C104-08 THROUGH C550-05 AND C900-07 THROUGH C950-07. ALL BRASS AND BRONZE PIPE, FITTINGS, AND VALVES SHALL MEET LOW LEAD COMPLIANCE REQUIREMENTS IN ACCORDANCE WITH ANSI/ASTM 371.
3. ALL PRODUCTS AND MATERIALS SHALL BE "MADE IN THE USA", UNLESS SPECIFICALLY APPROVED BY THE PARK CITY WATER DIRECTOR. STEEL AND IRON MATERIAL PRODUCTS SUCH AS PIPE, FITTINGS, VALVES, MANHOLE, METER VAULT, AND VALVE BOX CASTINGS SHALL BE "MELTED & MANUFACTURED IN THE USA". PARK CITY WATER ACKNOWLEDGES THAT CERTAIN SPECIALIZED WATER SYSTEM PRODUCTS INCLUDED IN THE ACCEPTABLE PRODUCTS LIST, SUCH AS HIGHER PRESSURE-RATED VALVES, MAY NOT MEET THE MADE IN USA REQUIREMENT AND ARE IN THE "QUALIFIED" MADE IN USA CATEGORY. THESE PRODUCTS HAVE BEEN PREVIOUSLY REVIEWED AND APPROVED.
4. UTAH DIVISION OF DRINKING WATER (DDW) APPROVALS:
 - a. FOR PROJECTS WITH TRANSMISSION AND/OR DISTRIBUTION LINES OVER 16 INCHES IN DIAMETER AND/OR INCLUDING A WATER BOOSTER STATION OR PRESSURE REDUCING STATION, DDW APPROVALS OUTLINED IN R309-500 MUST BE OBTAINED IN CONJUNCTION WITH SUBMITTAL OF A WATER MASTER PLAN TO THE CITY. FOLLOWING DESIGN REVIEW BY THE CITY AND INCORPORATION OF CITY COMMENTS, THE DESIGN ENGINEER SHALL SUBMIT WATER CONSTRUCTION PLANS TO THE DDW TO OBTAIN APPROVALS. NO WATER CONSTRUCTION SHALL COMMENCE UNTIL ALL REQUIRED DDW APPROVALS HAVE BEEN OBTAINED.
 - b. FOR PROJECTS WITH TRANSMISSION AND/OR DISTRIBUTION LINES OVER 16 INCHES IN DIAMETER AND/OR INCLUDING A WATER BOOSTER STATION OR PRESSURE REDUCING STATION A DDW FINAL OPERATING PERMIT IS REQUIRED PRIOR TO THE CITY OPERATING AND ACCEPTING THE WATER IMPROVEMENTS. FOLLOWING THE CITY'S WATER SYSTEM WALK-THROUGH AND THE CONTRACTOR'S SUBSEQUENT COMPLETION OF PUNCH-LIST ITEMS, THE CITY'S WATER DEPARTMENT WILL SUBMIT AN OPERATING PERMIT REQUEST TO THE DDW. THE FOLLOWING ITEMS ARE REQUIRED FROM THE DEVELOPER FOR THE CITY'S SUBMITTAL:
 - i. FINAL RECORD DRAWINGS AND O&M MANUALS
 - ii. HYDROSTATIC TESTING AND FLUSHING RECORDS (COMPLETED BY THE CITY'S INSPECTOR)
 - iii. ACCEPTABLE BACTERIOLOGICAL TESTING RESULTS
 - iv. CERTIFICATION BY THE (DEVELOPER'S) ENGINEER OF RECORD
5. THE CITY UTILIZES AN ADVANCED METERING INFRASTRUCTURE (AMI) SYSTEM. THE DEVELOPER MAY BE REQUIRED TO CONDUCT A PROPOGATION STUDY AND INSTALL RESULTING RECOMMENDED IMPROVEMENTS TO FACILITATE A CLEAR SIGNAL TO THE PROJECT. REFER TO STANDARD PLAN 520 FOR SPECIFIC METER TRANSMITTER UNIT (MXU) REQUIREMENTS.
6. REFER TO APPLICABLE STANDARD PLANS FOR WATER SYSTEM DETAILS AND REQUIREMENTS
7. EXTERNAL CORROSION PROTECTION SHALL BE INCLUDED ON ALL WATER SYSTEM IMPROVEMENTS, REFERENCE STANDARD PLAN 534 FOR REQUIREMENTS. A SOILS ANALYSIS MAY BE REQUIRED IN CONJUNCTION WITH THE DESIGN OF THE WATER SYSTEM TO DETERMINE THE EXTENT OF CORROSION PROTECTION REQUIRED.
8. REFER TO STANDARD PLAN 520 FOR GENERAL REQUIREMENTS FOR WATER METERS, METER VAULTS, AND WATER SERVICE LINES
9. CITY INSPECTION OF WATER SYSTEM IMPROVEMENTS WILL FOLLOW THE "*WATER SYSTEM FIELD OBSERVATION GUIDELINES*" AND ESTABLISHED CITY POLICIES. CONTRACTOR SHALL PROVIDE NECESSARY ASSISTANCE TO MEET THE GUIDELINE REQUIREMENTS.
10. NOTIFY WATER DEPARTMENT AT LEAST 5 BUSINESS DAYS BEFORE PERFORMING ANY WATER RELATED WORK. ARRANGE A PRECONSTRUCTION CONFERENCE SPECIFIC TO WATER CONSTRUCTION WITH THE CITY ENGINEER AND WATER DEPARTMENT AT LEAST 5 BUSINESS DAYS BEFORE START OF WORK. FOR PROJECTS INVOLVING ONLY SERVICE LINE AND/OR METER VAULT INSTALLATION, AN ON-SITE MEETING WITH THE CITY ENGINEER 48 HOURS PRIOR TO CONSTRUCTION IS ACCEPTABLE.
11. FOR TEMPORARY USE OF EXISTING WATER SYSTEM AND FIRE HYDRANTS TO OBTAIN CONSTRUCTION WATER, REFER TO STANDARD PLAN 531.

 PARK CITY MUNICIPAL CORPORATION WATER	DATE	GENERAL WATER NOTES	STD. PLAN
	05/2025		
	REV.		
	4		500.1

12. ALL CONSTRUCTION OF WATER SYSTEM SHALL BE CLEARLY STAKED BY THE DEVELOPER'S OR CONTRACTOR'S SURVEYOR. STAKING SHALL INCLUDE ALL BENDS, VALVES, HYDRANTS, SERVICES, METER VAULTS, AND SPECIALS. A MINIMUM OF 50-FOOT STATIONING IS REQUIRED FOR PIPELINE. PROVIDE RECORD DRAWINGS AND GEOSPATIAL DATA OF WATER INFRASTRUCTURE TO THE WATER DEPARTMENT.
13. CHANGES TO THE APPROVED WATER PLANS, INCLUDING PIPE ALIGNMENT, SIZE, AND DEPTH AS WELL AS FITTINGS, VALVES, SERVICES, AND METER VAULT LOCATIONS SHALL BE AUTHORIZED BY THE PUBLIC UTILITIES ENGINEER OR PUBLIC UTILITIES DEPARTMENT PRIOR TO INSTALLATION.
14. WATER SERVICE INTERRUPTION. THE FOLLOWING SHALL BE MET WITH RESPECT TO THE INTERRUPTION OF SERVICE TO CUSTOMERS INCLUDING THE SHUTDOWN OF THE EXISTING WATER SYSTEM:
 - a. CONTRACTOR SHALL NOT OPERATE EXISTING WATER VALVES
 - b. SCHEDULE SERVICE WORK REQUIRING WATER SERVICE INTERRUPTIONS OR SHUTDOWN OF THE EXISTING WATER SYSTEM A MINIMUM OF 96 HOURS IN ADVANCE WITH THE WATER DEPARTMENT (48HR WATER DEPARTMENT REVIEW, AND 48HR NOTIFICATION PERIOD)
 - c. LIMIT INTERRUPTIONS TO OCCUR AND BE COMPLETED ON MONDAY THRU FRIDAY, 9:00 AM TO 4:00 PM. NO INTERRUPTIONS SHALL OCCUR ON WEEKENDS, OR HOLIDAYS.
 - d. CONTRACTOR SHALL BE RESPONSIBLE FOR NOTIFICATION TO AFFECTED CUSTOMERS. CONTACT THE WATER DEPARTMENT FOR NOTIFICATION REQUIREMENTS. BE ADVISED THAT ON OCCASION VALVES IN THE EXISTING WATER SYSTEM MAY BE INOPERABLE AND MAY REQUIRE NOTIFICATION OF A LARGER AREA. IF VALVE MAINTENANCE IS REQUIRED, A SHUTDOWN DELAY OF SEVERAL DAYS SHOULD BE EXPECTED.
 - e. FOR WATER SHUTDOWNS LONGER THAN 8 HOURS, CONTRACTOR SHALL SUBMIT A TEMPORARY WATER PLAN TO KEEP ALL CUSTOMERS IN SERVICE. ALL COSTS ASSOCIATED WITH MAINTAINING SERVICE TO AFFECTED CUSTOMERS SHALL BE BORNE BY THE CONTRACTOR
 - f. THE WATER DEPARTMENT RESERVES THE RIGHT TO RESTRICT, MODIFY, OR DENY APPLICATIONS AS NEEDED TO MINIMIZE WATER SERVICE INTERRUPTIONS AND PROTECT PUBLIC HEALTH.
 - g. CONTRACTOR SHALL HAVE ALL PERTINENT PARTS AND MATERIALS ON SITE PRIOR TO SHUTDOWN OF THE WATER SYSTEM BY THE WATER DEPARTMENT
 - h. CONSTRUCTION EXCAVATION MUST BE PREPARED AND THE WATER MAIN EXPOSED PRIOR TO SHUTDOWN OF THE WATER SYSTEM
15. EXPOSE EXISTING WATER PIPES AND VERIFY HORIZONTAL AND VERTICAL LOCATION PRIOR TO INSTALLING NEW IMPROVEMENTS, POTHOLE ANY AND ALL UTILITIES TO ELIMINATE POTENTIAL CONFLICTS
16. THE HORIZONTAL DISTANCE BETWEEN WATER LINES AND SANITARY SEWER LINES SHALL BE AT LEAST 10 FEET. WHERE A WATER MAIN AND SEWER MUST CROSS, THE WATER MAIN SHALL BE AT LEAST 18 INCHES ABOVE THE SEWER LINE. SEPARATION DISTANCES SHALL BE MEASURED EDGE-TO-EDGE (I.E. FROM THE NEAREST EDGES OF THE FACILITIES)
17. IF THE BASIC SEPARATION STANDARDS CANNOT BE MET, AN EXCEPTION TO THE RULE CAN BE APPLIED WITH ADDITIONAL MITIGATION MEASURES TO PROTECT PUBLIC HEALTH, IN ACCORDANCE WITH UTAH ADMINISTRATIVE CODE R309-105-6(2)(B).
18. THE OPEN ENDS OF ALL PIPELINES UNDER CONSTRUCTION SHALL BE COVERED AND EFFECTIVELY SEALED AT THE END OF THE DAY'S WORK.
19. PROVIDE ACCESS TO EXISTING MAIN LINE VALVES THROUGHOUT CONSTRUCTION. ALL VALVES MUST BE ACCESSIBLE WITHIN 24 HOURS AFTER PAVING OR COLLAR ADJUSTMENTS.
20. UNDER NO CIRCUMSTANCE SHALL THE PIPE OR ACCESSORIES BE DROPPED INTO THE TRENCH.
21. WHERE JOINING EXISTING ASBESTOS CEMENT PIPE, CUT IN ACCORDANCE WITH OSHA REQUIREMENTS AND DISPOSE OF IN ACCORDANCE WITH APPLICABLE ENVIRONMENTAL REGULATIONS.
22. PROVIDE EXTENSIONS ON VALVE STEM TOPS HAVING OVER 5 FEET BURY. REFER TO STANDARD PLAN 570.
23. INSTALL AIR AND VACUUM VALVES PER STANDARD PLANS 574 AND 575 AT HIGH POINTS (8" DIAMETER PIPE OR LARGER) AS DEEMED NECESSARY BY THE DESIGN ENGINEER AND CITY.
24. THRUST BLOCKING IS REQUIRED ON ALL WATER MAIN AND FIRE LINES. REFER TO STANDARD PLANS 561 AND 562
25. REMOVE AND CORRECT DEFECTIVE WORK WITHIN 24 HOURS FOLLOWING WRITTEN NOTIFICATION BY THE CITY ENGINEER.
26. CONSTRUCT TEMPORARY FLUSHING VALVES/BLOW-OFF PIPING ON THE END OF NEW WATER MAINS AS REQUIRED TO MEET FLUSHING REQUIREMENTS. CONSULT WITH PUBLIC UTILITIES ENGINEER TO DETERMINE ACCEPTABLE LOCATIONS AND SIZING REQUIREMENTS. MINIMUM ACCEPTABLE FLUSHING VELOCITY FOR INITIAL FLUSH IS 3 FEET PER SECOND. DO NOT PERFORM INITIAL FLUSH THROUGH FIRE HYDRANTS WITHOUT APPROVAL FROM PARK CITY PUBLIC UTILITIES ENGINEER. ALL INTERNAL COMPONENTS OF FIRE HYDRANT TO BE REMOVED BY CONTRACTOR PRIOR TO INITIAL FLUSHING. CONTRACTOR TO BE RESPONSIBLE FOR REINSTALLATION OF COMPONENTS AND RESPONSIBLE FOR ANY DAMAGES.

 PARK CITY MUNICIPAL CORPORATION WATER	DATE	GENERAL WATER NOTES	STD. PLAN
	05/2025		
	REV.		
	4		500.2

27. ALL TYPES OF INSTALLED PIPE SHALL BE PRESSURE TESTED AND LEAKAGE TESTED IN ACCORDANCE WITH AWWA STANDARD C600-10
28. ALL NEW WATER MAINS OR APPURTENANCES SHALL BE DISINFECTED IN ACCORDANCE WITH AWWA STANDARD C651 OR A METHOD APPROVED BY THE PUBLIC UTILITIES ENGINEER. THE SPECIFICATIONS SHALL INCLUDE DETAILED PROCEDURES FOR THE ADEQUATE FLUSHING, DISINFECTION AND MICROBIOLOGICAL TESTING OF ALL WATER MAINS. ON ALL NEW AND EXTENSIVE DISTRIBUTION SYSTEM CONSTRUCTION, EVIDENCE OF SATISFACTORY DISINFECTION SHALL BE PROVIDED TO THE PUBLIC UTILITIES ENGINEER. SAMPLES FOR COLIFORM ANALYSES SHALL BE COLLECTED AFTER DISINFECTION IS COMPLETE AND THE SYSTEM IS REFILLED WITH DRINKING WATER. A STANDARD HETEROTROPHIC PLATE COUNT IS ADVISABLE. THE USE OF WATER FOR PUBLIC DRINKING WATER PURPOSES SHALL NOT COMMENCE UNTIL THE BACTERIOLOGICAL TESTS INDICATE THE WATER IS FREE FROM CONTAMINATION.
29. DISINFECTING, FLUSHING, AND HYDROSTATIC PLANS SHALL BE SUBMITTED TO THE PUBLIC UTILITIES ENGINEER A MINIMUM OF 5 WORKING DAYS PRIOR TO COMMENCEMENT OF ACTIVITY. CONTRACTOR SHALL NOT OPERATE EXISTING WATER VALVES.
30. BACKFLOW PREVENTION DEVICES MAY BE REQUIRED. IF REQUIRED, THE CITY MAY NOT SET A WATER METER UNTIL AN APPROVED AND TESTED BACKFLOW DEVICE IS INSTALLED AND INSPECTED
31. ALL BACKFLOW PREVENTERS HAVE TO BE TESTED ANNUALLY TO ENSURE THAT THEY ARE FUNCTIONING PROPERLY. A VISUAL CHECK OF AIR GAPS IS SUFFICIENT, BUT MECHANICAL BACKFLOW PREVENTERS HAVE TO BE TESTED BY A STATE CERTIFIED BACKFLOW SPECIALIST, WITH PROPERLY CALIBRATED GAUGE EQUIPMENT. TO OBTAIN A LIST OF STATE CERTIFIED TESTERS REFER TO THE UTAH DIVISION OF DRINKING WATER (DDW), CROSS CONNECTION CONTROL & BACKFLOW PREVENTION WEBSITE.
32. FIRE SPRINKLER SYSTEM BOOSTER PUMPS: FIRE SPRINKLER SYSTEM PUMPS, INTEGRAL TO THE FIRE SPRINKLER PIPING, TO MEET FIRE SPRINKLER PRESSURE DESIGN REQUIREMENTS ARE CONSIDERED OUTSIDE THE INTENT OF UTAH DDW REGULATION R309-550-11(3) AND DO NOT REQUIRE APPROVAL OF THE DDW IF THEIR INSTALLATION CONFORMS TO UTAH ADOPTED PLUMBING CODE AND NATIONAL FIRE PROTECTION ASSOCIATION (NFPA) 13 D. PUMPS SHALL BE CONNECTED ON THE BUILDING SIDE OF THE WATER METER VAULT AND SHALL BE APPROVED BY THE CITY ENGINEER AND BUILDING DEPARTMENT. PUMP APPROVAL IS FOR FIRE SPRINKLER SYSTEMS ONLY AND NOT FOR DOMESTIC USE.

 PARK CITY MUNICIPAL CORPORATION WATER	DATE	GENERAL WATER NOTES	STD. PLAN
	05/2025		500.3
	REV.		
	4		

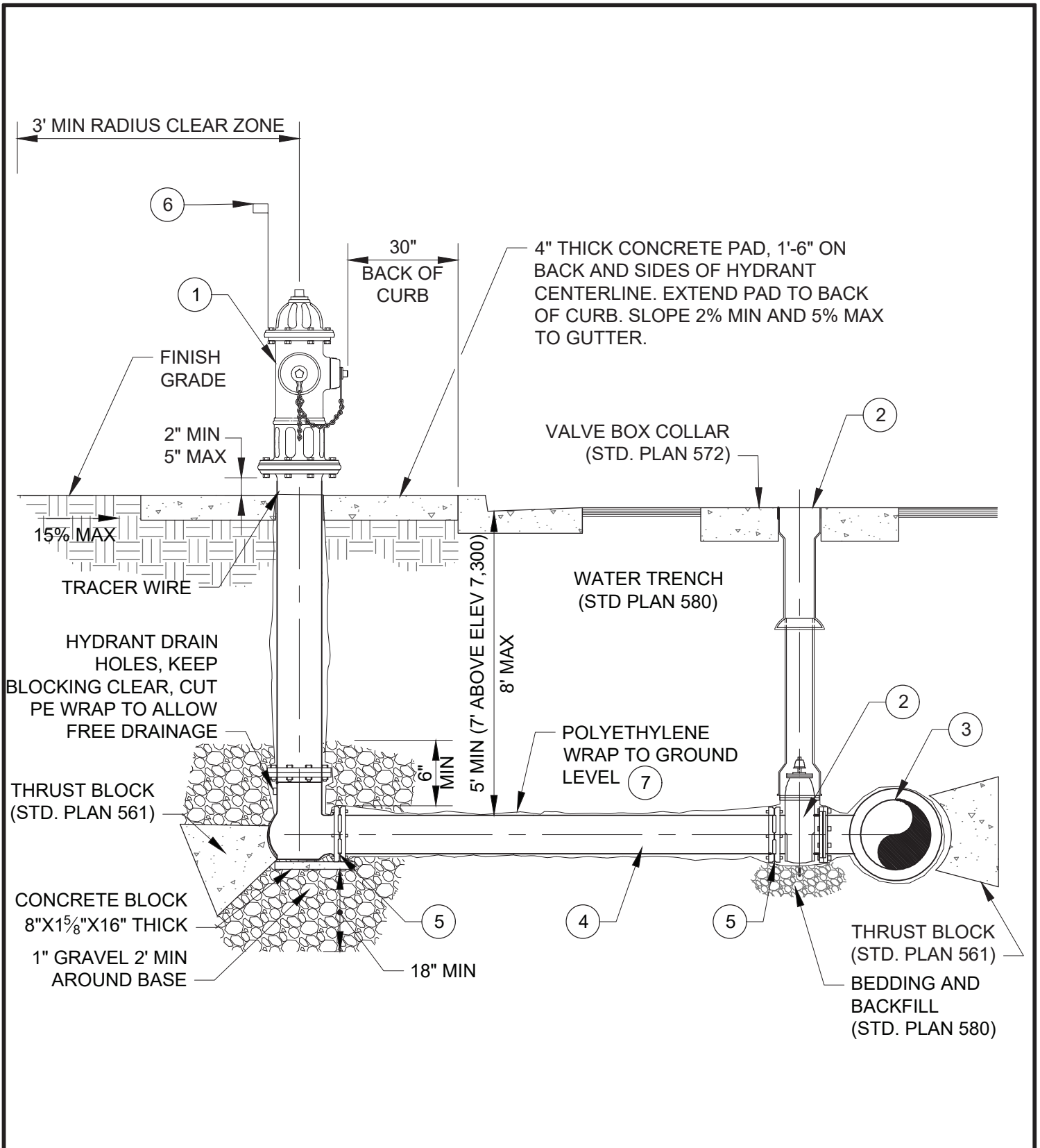

NOTES:

- REFER TO STD. PLAN 511-S FOR LEGEND ITEMS, APPROVED PARTS LIST, AND DETAIL NOTES.

 PARK CITY MUNICIPAL CORPORATION WATER	DATE	<h1>FIRE HYDRANT</h1>	STD. PLAN
	03/2024		<h1>511</h1>
	REV.		
	2		

LEGEND AND APPROVED PARTS LIST

ITEM	DESCRIPTION	ACCEPTABLE MANUFACTURER	MODELS
①	FIRE HYDRANT, DRY BARREL, AWWA C502	MUELLER	SUPER CENTURION 250 3-WAY A-423, 5-1/4 PUMPER NOZZLE, NATIONAL STD. OPERATING NUT (OPENS LEFT) OR EQUAL IF UNAVAILABLE
②	BURIED VALVE AND VALVE BOX (STD. PLAN 570), 6" GATE VALVE, NRS, FLG X MJ, 2" SQ. OPERATING NUT, AWWA C509	MUELLER	SERIES 2360, SST BONNET BOLTS OR EQUAL
③	6" DUCTILE IRON FLANGE TEE (OR TAPPING SEE DETAIL 542), AWWA C110		
④	HYDRANT SERVICE LINE, 6" DIAMETER C900 PVC, DR14, RESTRAINED JOINTS (STD PLAN 540)		
⑤	MECHANICAL JOINT RESTRAINT OR SST TIE ROD / NUT RESTRAINTS	EBBA IRON	MEGALUG SERIES 1100, STD T-BOLTS AND NUTS
⑥	HYDRANT MARKER, HEAVY DUTY FIBERGLASS WITH RED FLAG, TOP MOUNT, 5' LENGTH (STD.), 6' LENGTH (ABOVE 7300' ELEVATION)	POLLARD	REFLECTIVE HYDRANT MARKER MODEL P69161 (STD.) AND P69170 (ABOVE 7300') WITH FLAG MODEL P691801, OR APPROVED EQUAL
⑦	POLYETHYLENE ENCASEMENT, V-BIO ENHANCED POLYETHYLENE ENCASEMENT FILM, AWWA C105 & AWWA C703E METHOD A & C	US PIPE	AWWA C703E METHOD A (4 MIL) AT PIPE AND AWWA C703E METHOD C (10 MIL) AT BOLT-TYPE JOINTS, FITTINGS AND VALVES

DETAIL NOTES

1. LOCATE HYDRANT AS SHOWN ON THE APPROVED PLANS
2. SET HYDRANT PLUMB WITH PUMPER NOZZLE FACING STREET
3. ADJUST TO GRADE WITH MAXIMUM OF ONE (1) HYDRANT BARREL EXTENSION (AWWA C502)
4. PROVIDE 316 STAINLESS STEEL BOLTS FOR ANY FLANGES THAT ARE BELOW GRADE INCLUDING BOLTS FOR HYDRANT RISERS. 304 STAINLESS STEEL BOLTS ARE ACCEPTABLE FOR EXPOSED/ABOVE GRADE FLANGES.
5. RECOAT DAMAGED OR MARRED HYDRANT COATING AFTER INSTALLATION (UV RESISTANT, HIGH GLOSS, POLYURETHANE ENAMEL COATING, FIRE HYDRANT RED)
6. REFER TO SPECIFICATIONS FOR FLUSHING, HYDROSTATIC TESTING, AND DISINFECTING REQUIREMENTS
7. APPLY WAX TAPE COATING SYSTEM TO VALVE BONNET BOLTS AND ALL OTHER BURIED BOLTS, NUTS, CONNECTORS, AND COUPLINGS, AWWA C 217. (STD PLAN 534)
8. CATHODICALLY PROTECT PIPE AND OR FITTINGS, WHEN EXISTING SOIL CONDITIONS REQUIRE PER SOILS ANALYSIS (STD. PLAN 534)
9. HYDRANT DRAINS SHALL NOT BE CONNECTED TO, OR LOCATED WITHIN, 10 FEET OF SANITARY SEWERS. WHERE POSSIBLE, HYDRANT DRAINS SHALL NOT BE LOCATED WITHIN 10 FEET OF STORM DRAINS.

 PARK CITY MUNICIPAL CORPORATION WATER	DATE	FIRE HYDRANT	STD. PLAN
	03/2024		511 S
	REV.		
	3		

GENERAL REQUIREMENTS – WATER METER, METER VAULT, AND SERVICE LINE

REFER TO SPECIFICATIONS AND STANDARD PLANS FOR DETAILED WATER METER, METER VAULT, AND SERVICE LINE REQUIREMENTS

WATER METER & METER VAULT:

1. WATER METER AND RADIOREAD METER TRANSCEIVER UNIT (MXU) WILL BE PROVIDED BY THE CITY. ALL OTHER COMPONENTS SHALL BE PROVIDED AND INSTALLED BY THE DEVELOPER/BUILDER. PROVIDE 2 WEEKS ADVANCE NOTICE TO THE WATER DEPARTMENT FOR METER SET REQUESTS EXCEEDING FIVE METERS OR METER SIZES GREATER THAN 2 INCHES. APPROPRIATE METER APPLICATION AND PAYMENT OF FEES APPLY BEFORE THE CITY WILL SET A METER.
2. WATER METER SIZE, AND WATER SERVICE LINE SIZE SHALL BE APPROVED BY THE PUBLIC UTILITY ENGINEER PRIOR TO INSTALLATION OF ANY SERVICE LINE, METER VAULT, OR WATER MAIN TAP. APPROVED WATER METER SIZING CALCULATIONS, INCLUDING WATER SERVICE LINE SIZING FROM THE METER TO THE STRUCTURE ARE REQUIRED. A 2" MINIMUM WATER SERVICE SIZE IS REQUIRED FROM THE MAIN LINE.
3. INSTALLATION OF A WATER METER EXCEEDING 2-INCH WILL REQUIRE PUBLIC UTILITIES ENGINEER APPROVAL. THE METER AND VAULT WILL REQUIRE AN APPROVED FLOWRATE AND DEMAND ANALYSIS BY THE DEVELOPER / BUILDER AND A SITE SPECIFIC DESIGN.
4. INSTALLATION OF A WATER SERVICE LINE SIZE FOR A 2" METER AND GREATER WILL REQUIRE PUBLIC UTILITIES ENGINEER APPROVAL. THE SERVICE LINE REQUEST WILL REQUIRE SUBMITTAL OF AN APPROVED FLOWRATE AND DEMAND ANALYSIS BY THE DEVELOPER/BUILDER.
5. USE OF AN INSIDE WATER METER WILL REQUIRE PUBLIC UTILITIES ENGINEER APPROVAL. INSIDE METERS SHALL BE USED ONLY FOR COMMERCIAL OR MULTI-UNIT BUILDINGS SUBJECT TO THE FOLLOWING CONDITIONS:
 - A. UNRESTRICTED ACCESS IS AVAILABLE TO WATER DEPARTMENT PERSONNEL
 - B. THE METER SHALL BE LOCATED IN A SEPARATE MECHANICAL ROOM
 - C. THE METER SHALL BE ASSOCIATED WITH FIRE PROTECTION SPRINKLER SYSTEM (FIRE STACK) PLUMBING
 - D. THE METER REQUIRES A SITE SPECIFIC DESIGN APPROVED BY THE FIRE MARSHAL, THE PARK CITY BUILDING DEPARTMENT, CITY ENGINEER, PUBLIC UTILITIES DEPARTMENT, AND THE PUBLIC UTILITIES WATER RESOURCE MANAGER. LAYOUT SHALL BE CONSISTENT WITH WATER STANDARD PLANS 523, 526, AND 528
 - E. A REMOTE RADIOREAD METER TRANSCEIVER UNIT (MXU) DEVICE SHALL BE INSTALLED AT A LOCATION ACCEPTABLE TO THE WATER DEPARTMENT. REFER TO NOTE 11.
6. METER VAULT LOCATION SHALL BE APPROVED BY THE PUBLIC UTILITIES ENGINEER PRIOR TO INSTALLATION OF ANY SERVICE LINE OR WATER MAIN TAP. MINIMUM REQUIREMENTS AROUND METER VAULT MUST BE MET. NO POWER, IRRIGATION, COMMUNICATION, CABLING, ECT. WITHIN METER VAULT CLEARANCE AREA.
7. LOCATE METER VAULT, WHENEVER POSSIBLE, IN LANDSCAPE AREAS. PLACEMENT WITHIN A PAVED SURFACE, DRIVEWAY OR WALKWAY, REQUIRES WRITTEN APPROVAL PRIOR TO INSTALLATION OF THE SERVICE LINE OR WATER MAIN TAP. THE METER VAULT SHALL BE PLACED AT THE PUBLIC RIGHT OF WAY LINE. IN THE ABSENCE OF A PUBLIC R-O-W LINE, THE METER VAULT SHALL BE LOCATED WITHIN A DEDICATED EASEMENT AND A MAXIMUM OF FIVE FEET BEHIND THE CURB AND GUTTER OR SIDEWALK AS APPLICABLE.
8. EXTEND THE SERVICE LINE STUB ON THE CUSTOMER SIDE TO 5 FEET BEYOND THE METER VAULT WITH METER VAULT CONSTRUCTION. INSTALL END CAP AND MARKER ON SERVICE LINE TERMINATION.
9. LOCATE METER VAULT TO PROVIDE CONVENIENT, SAFE, AND UNINHIBITED ACCESS FROM A PUBLIC ROW OR WATER EASEMENT. NO FENCES SHALL BE LOCATED BETWEEN THE ROW/EASEMENT LINE AND THE METER VAULT. NO OBSTRUCTIONS OR UTILITIES SHALL BE LOCATED WITHIN 3 FEET OF THE OUTSIDE WALL OF THE METER VAULT. NO BUSHES, SHRUBS, OR PLANTS SHALL BE WITHIN 2 FEET OF THE METER LID AND NO TREES SHALL BE PLANTED SUCH THAT THE DRIP LINE AT MATURITY WILL BE WITHIN 3 FEET OF THE METER LID.

 PARK CITY MUNICIPAL CORPORATION WATER	DATE	GENERAL REQUIREMENTS WATER METER, METER VAULT AND SERVICE LINE	STD. PLAN
	04/2025		520.1
	REV.		
	3		

10. SET METER VAULT SET FLUSH WITH THE FINAL LANDSCAPE OR PAVEMENT GRADE. IF THE GROUND IS NOT TO FINAL GRADE AT THE TIME OF THE METER INSTALLATION OR INSPECTION, ADJUST METER VAULT WHEN FINAL GRADE IS ESTABLISHED AND ADJUST THE METER SETTER TO MEET REQUIRED VAULT DIMENSIONS. REFERENCE STANDARD PLANS 592 AND 593 FOR METER VAULT GRADING REQUIREMENTS.
11. IN MOST CASES THE METER TRANSCEIVER UNIT (MXU) DEVICE WILL MOUNT THROUGH THE METER VAULT LID. IF METER LOCATION DOES NOT PERMIT A CLEAR RELIABLE MXU DEVICE RADIO SIGNAL TO CITY FACILITIES, A REMOTE MXU DEVICE WILL BE REQUIRED. THE REMOTE MXU DEVICE WILL BE INSTALLED BY THE CITY, AT A LOCATION DETERMINED BY THE CITY, AT THE TIME OF THE METER INSPECTION. IN MOST CASES THE REMOTE MXU DEVICE WILL BE INSTALLED ON THE OUTSIDE OF THE BUILDING FACING A PUBLIC STREET. PROVIDE CONDUIT AND SIGNAL WIRE FROM METER VAULT TO REMOTE MXU DEVICE LOCATION, REFERENCE STANDARD PLAN 530. FOR DEVELOPMENT PROJECTS, A SIGNAL PROPAGATION STUDY AND INSTALLATION OF A NEW REPEATER STATION AT THE DEVELOPER'S EXPENSE MAY BE REQUIRED.
12. IF REPLACING METER VAULT, PROTECT EXISTING METER AND MXU DEVICE, TAG OR LEAVE IN VAULT. CONTACT PARK CITY WATER DEPARTMENT PRIOR TO REMOVING OR REPLACING METER.
13. PROTECT METER VAULT AND MXU DEVICE THROUGHOUT CONSTRUCTION.
14. A WATER METER WILL NOT BE SET BY THE CITY UNTIL THE METER VAULT AND SERVICE LINE ARE IN COMPLIANCE WITH THE MOST CURRENT VERSION OF THE ENGINEERING STANDARDS, STANDARD DRAWINGS, AND APPROVED PROJECT DRAWINGS, A METER INSPECTION HAS BEEN PERFORMED AND DEFICIENCIES CORRECTED, AND ALL APPLICABLE FEES PAID.
15. ALL BRASS AND BRONZE PIPE, FITTINGS, AND VALVES SHALL MEET LOW LEAD COMPLIANCE REQUIREMENTS IN ACCORDANCE WITH ANSI/ASTM 371.
16. PROVIDE COMPRESSION STYLE FITTINGS AND VALVES. FLARED STYLE CONNECTIONS ARE NOT ALLOWED.

SERVICE LINE:

1. ROUTE SERVICE LINES AT A 90 DEGREE ANGLE TO THE FRONT PROPERTY/R-O-W/EASEMENT LINE FROM THE WATER MAIN. AVOID ROUTING SERVICE LINES UNDER DRIVEWAYS.
2. MAINTAIN 5 FEET OF HORIZONTAL SEPARATION BETWEEN TAP LOCATION AND UTILITY CROSSINGS.
3. DUCTILE IRON WATER MAIN: MAINTAIN 2 FEET SEPARATION BETWEEN SERVICE LINE TAP AND ALL MAIN LINE FITTINGS, VALVES, PIPE JOINTS, AND OTHER SERVICE TAPS.
4. PVC WATER MAIN: MAINTAIN 3 FEET SEPARATION BETWEEN SERVICE LINE TAP AND ALL MAIN LINE FITTINGS, VALVES, PIPE JOINTS, AND OTHER SERVICE TAPS.
5. WATER SERVICE LINE SHALL BE CONTINUOUS. NO BENDS, FITTINGS, COUPLERS, OR CONNECTIONS, ARE PERMITTED BETWEEN WATER MAIN CORPORATION STOP AND THE METER VAULT CURB VALVE.
6. PROVIDE COMPRESSION STYLE VALVES FITTINGS. FLARED STYLE CONNECTIONS ARE NOT ALLOWED.
7. METER VAULTS AND SERVICE LINES MUST BE INSPECTED BY THE CITY PRIOR TO BACKFILLING, UNLESS SPECIFIC PRIOR APPROVAL IS PROVIDED BY THE CITY.
8. TAPPING NEW CONSTRUCTION WATER MAIN: NOTIFY AND SECURE INSPECTION OF INSTALLATION BY PUBLIC UTILITIES ENGINEER OR WATER DEPARTMENT PRIOR TO TAPPING WATER MAIN. PROVIDE TAPPING "COUPON" TO THE WATER DEPARTMENT.
9. TAPPING EXISTING WATER MAIN: NOTIFY AND SECURE INSPECTION OF INSTALLATION BY PUBLIC UTILITIES ENGINEER OR WATER DEPARTMENT 3 BUSINESS DAYS PRIOR TO TAPPING WATER MAIN. PROVIDE TAPPING "COUPON" TO THE WATER DEPARTMENT.
10. SERVICES LINES LARGER THAN 2-INCH DIAMETER SHALL MEET WATER MAIN REQUIREMENTS.
11. ALL BRASS AND BRONZE PIPE, FITTINGS, AND VALVES SHALL MEET LOW LEAD COMPLIANCE REQUIREMENTS IN ACCORDANCE WITH ANSI/ASTM 371
12. DISINFECT ALL NEW WATER SERVICES AND APPURTENANCES IN ACCORDANCE WITH AWWA STANDARD C651, THE SPECIAL REQUIREMENTS OF THE *PARK CITY DESIGN STANDARDS, CONSTRUCTION SPECIFICATIONS, AND STANDARD DETAILS*, AND THE *PARK CITY WATER SYSTEM FIELD OBSERVATION GUIDELINES*. DISINFECTING, FLUSHING, AND HYDROSTATIC PLANS SHALL BE SUBMITTED TO THE PUBLIC UTILITIES ENGINEER A MINIMUM OF 5 WORKING DAYS PRIOR TO COMMENCEMENT OF ACTIVITY. CONTRACTOR SHALL NOT OPERATE EXISTING WATER VALVES.
13. TRACER WIRE IS REQUIRED FROM WATER MAIN TO METER VAULT.
14. ALL BURIED FITTINGS SHALL BE WAXED TAPED (CORPORATION STOPS, SADDLES, ECT.)
15. NO IRRIGATION CONNECTIONS ARE ALLOWED WITHIN METER VAULT.

 PARK CITY MUNICIPAL CORPORATION WATER	DATE	GENERAL REQUIREMENTS WATER METER, METER VAULT AND SERVICE LINE	STD. PLAN
	04/2025		520.2
	REV.		
	3		

LEGEND AND APPROVED PARTS LIST

ITEM	DESCRIPTION	ACCEPTABLE MANUFACTURER	MODELS
①	METER VAULT FRAME AND COVER (STD. PLAN 529)		
②	MXU REMOTE LOCATION CONDUIT WITH END CAPS, SCH 40 PVC (STD. PLAN 530)		
③	24" DIAMETER METER VAULT PAVED AREAS: REINF. CONCRETE PIPE LANDSCAPE AREAS: CORRUGATED DUAL-WALL HDPE PIPE	HDPE PIPE: ADS	HDPE: MEGA GREEN N-12, OR APPROVED EQUAL
④	METER, SUPPLIED AND INSTALLED BY PCMC	SENSUS	iPERL
⑤	3/4" METER YOKE	MUELLER	5/8"x3/4"x9" B2410N-6AN
		FORD	5/8"x3/4" VBHC72-9W-11-33-NL
	1" METER YOKE	MUELLER	1"x12" B2410N-6AN
		FORD	1" VBHC74-12W-11-33-NL
⑥	3/4" OR 1" METER YOKE END CONNECTION	MUELLER	MULTI X M.I.P, H-14223N
		FORD	3/4" OR 1" CLOSE BRASS NIPPLE
⑦	2" X 3/4" OR 1" BRONZE BUSHING		
⑧	2" CURB VALVE, F.I.P. X CTS (INLET)	MUELLER	B-25172N
		FORD	B41-66Q
⑨	CONNECTION, F.I.P. X CTS (OUTLET) SIZE NOT TO EXCEED METER SIZE	MUELLER	
		FORD	
⑩	END CAP AND MARKER, CTS X F.I.P. (OUTLET)	MUELLER	H-15451N AND H-10035N
⑪	MXU AND WIRING, SUPPLIED AND INSTALLED BY PCMC		

DETAIL NOTES

1. LOCATE METER VAULT PER APPROVED PLANS AND SET METER BOX PLUMB
2. SST INSERT STIFFENERS REQUIRED ON ALL CTS TUBING CONNECTIONS
3. WAX TAPE ALL BURIED FITTINGS (CORP STOP, SADDLE, ECT.)
4. TRACER WIRE FROM WATER MAIN TO METER VAULT

 PARK CITY MUNICIPAL CORPORATION WATER	DATE	3/4" AND 1" SINGLE METER OUTSIDE SETTING	STD. PLAN
	3/2024		521 S
	REV.		
	2		

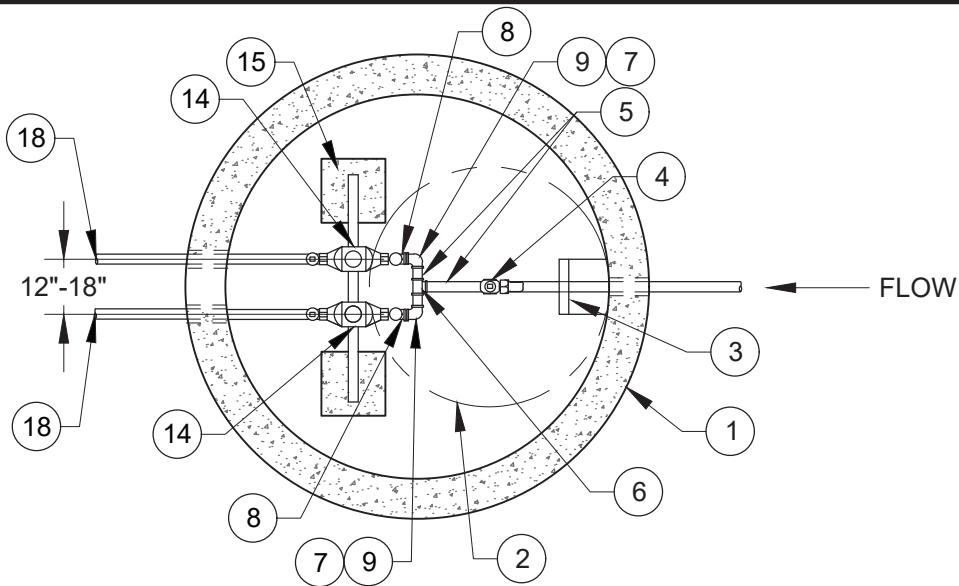

PLAN
NTS

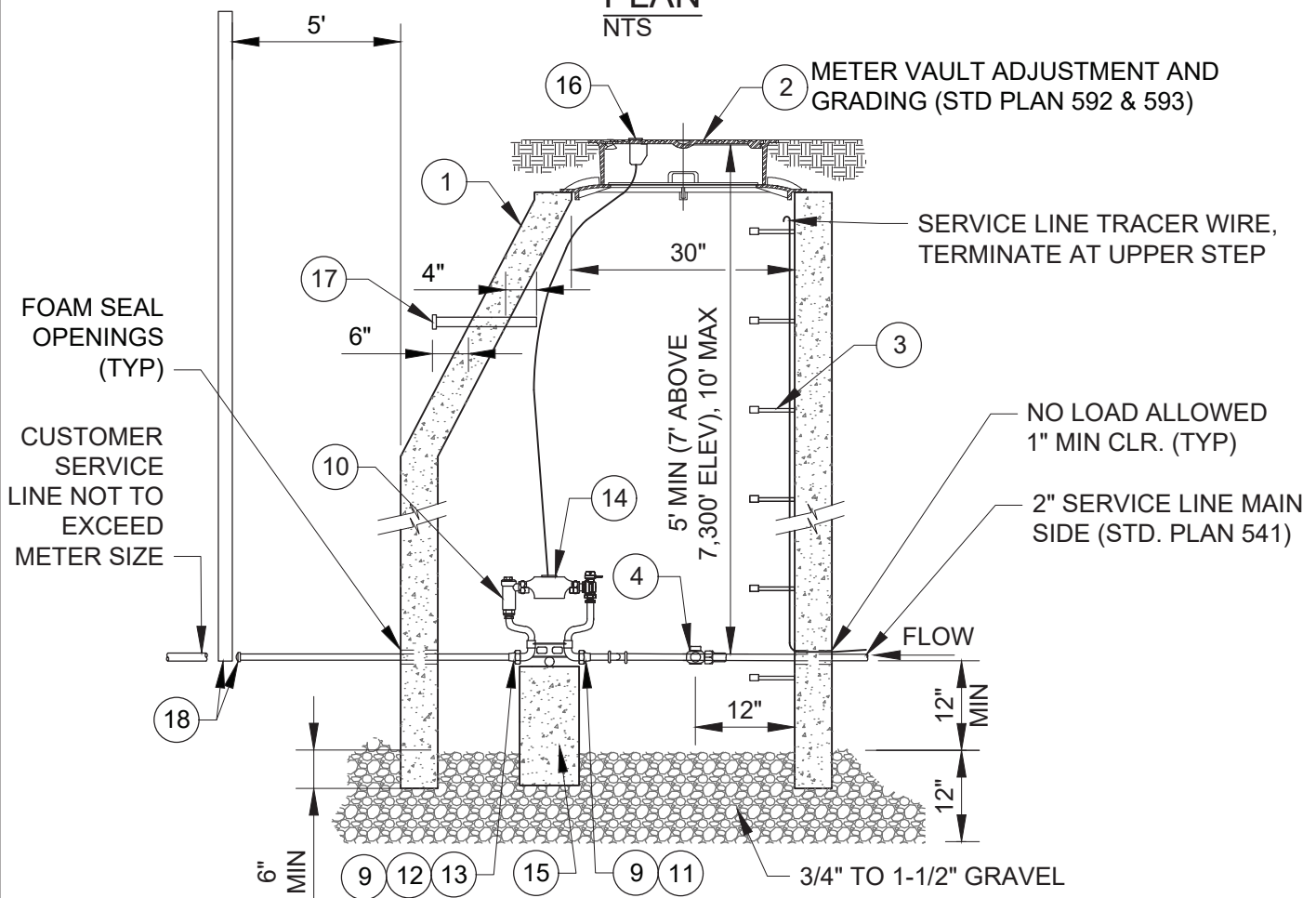

SECTION
NTS

NOTES:

1. REFER TO STD. PLAN 520 FOR GENERAL REQUIREMENTS - METER, METER VAULT, AND SERVICE LINE.
2. REFER TO STD. PLAN 522 S FOR LEGEND ITEMS, APPROVED PARTS LIST, AND DETAIL NOTES.

 PARK CITY MUNICIPAL CORPORATION WATER	DATE	3/4" AND 1" DUAL METERS OUTSIDE SETTING	STD. PLAN
	03/2024		522
	REV.		
	2		

LEGEND AND APPROVED PARTS LIST

ITEM	DESCRIPTION	ACCEPTABLE MANUFACTURER	MODELS
①	5' DIA. MANHOLE, PRECAST CONCRETE ECCENTRIC CONE AND WALL SECTIONS		ASTM C 478
②	METER VAULT FRAME AND COVER (STD PLAN 529)		
③	POLYPROPYLENE ENCASED GRADE 60 STEEL STEPS AT 13" C-C, 13-1/2" TREAD WIDTH	M.A. INDUSTRIES OR APP'D EQUAL	PS2-PFDF
④	2" CURB VALVE	MUELLER	B-25172N
		FORD	B41-666Q
⑤	2" DIA. BRASS NIPPLE X 6" LENGTH, M.I.P.		
⑥	2" DIA. BRONZE TEE, F.I.P., THREADED		
⑦	2" BRONZE 90° ELBOW, F.I.P., THREADED (2 EA)		
⑧	2" BRASS NIPPLE X 4" LENGTH, M.I.P. (2 EA)		
⑨	BRONZE BELL REDUCER REQ'D (2 EA) 3/4" YOKE: 2" X 3/4" 1" YOKE: 2" X 1" DIA.		
⑩	3/4" METER YOKE (2 EA)	MUELLER	5/8"x3/4"x18" B-2404-6AN
		FORD	5/8"x3/4" VBHC72-18W-11-33-NL
	1" METER YOKE (2 EA)	MUELLER	1"x18" B-2404-6AN
		FORD	1" VBHC74-18W-11-44-NL
⑪	3/4" OR 1" METER YOKE END CONNECTIONS (2 EA)	MUELLER	MULTI X M.I.P., H-14223N
		FORD	3/4" OR 1" CLOSE BRASS NIPPLE
⑫	2" x 3/4" OR 1" BRONZE BUSHING (OUTLET) (2 EA)		
⑬	2" CONNECTION, F.I.P. X CTS (OUTLET) (2 EA)	MUELLER	H-15451N
		FORD	C-14-66-G-NL
⑭	METER, SUPPLIED AND INSTALLED BY PCMC (2 EA)	SENSUS	iPERL
⑮	PIPE SUPPORTS, GALVANIZED PIPE SUPPORT ROD AND (2) 16"x8"x8" CMU BLOCK		
⑯	MXU AND WIRING, SUPPLIED AND INSTALLED BY PCMC		
⑰	MXU REMOTE LOCATION CONDUIT WITH END CAPS, SCH 40 PVC (STD. PLAN 531)		
⑱	END CAP AND MARKER, CTS X F.I.P. (OUTLET) (2 EA)	MUELLER	H-15451N AND H-10035N

DETAIL NOTES

1. LOCATE METER VAULT PER APPROVED PLANS AND SET METER BOX PLUMB
2. SST INSERT STIFFENERS REQUIRED ON ALL CTS TUBING CONNECTION
3. USE PIPE DOPE OR TEFLON TAPE ON THREADED FITTINGS
4. WAX TAPE ALL BURIED FITTINGS. TRACER WIRE REQUIRED FROM WATER MAIN TO METER

 PARK CITY MUNICIPAL CORPORATION WATER	DATE	3/4" AND 1" DUAL METERS OUTSIDE SETTING	STD. PLAN
	3/2024		522 S
	REV.		
	2		

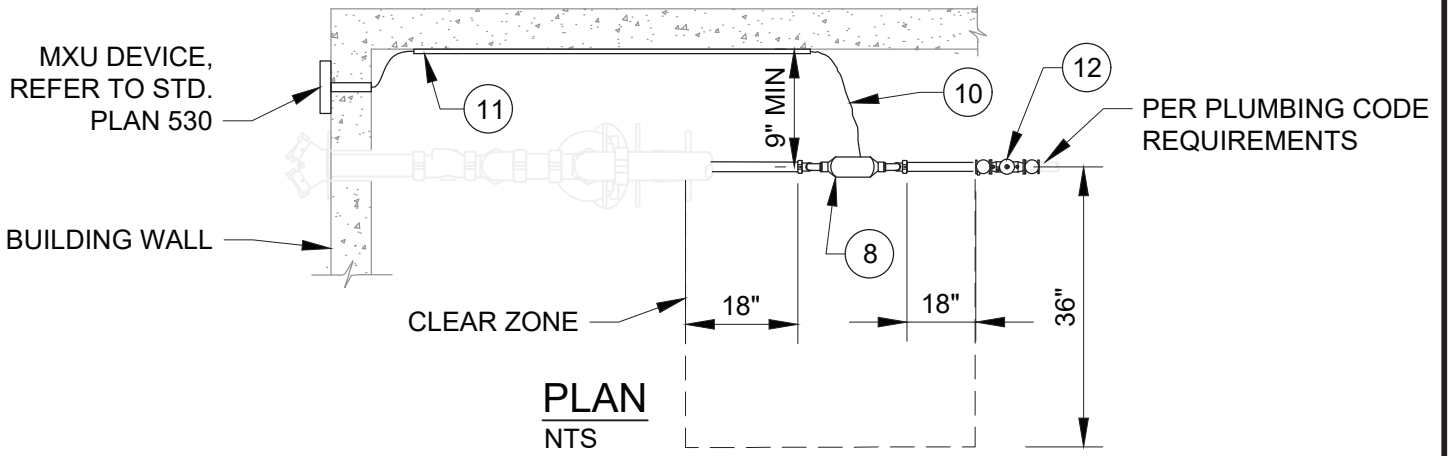

PLAN
NTS

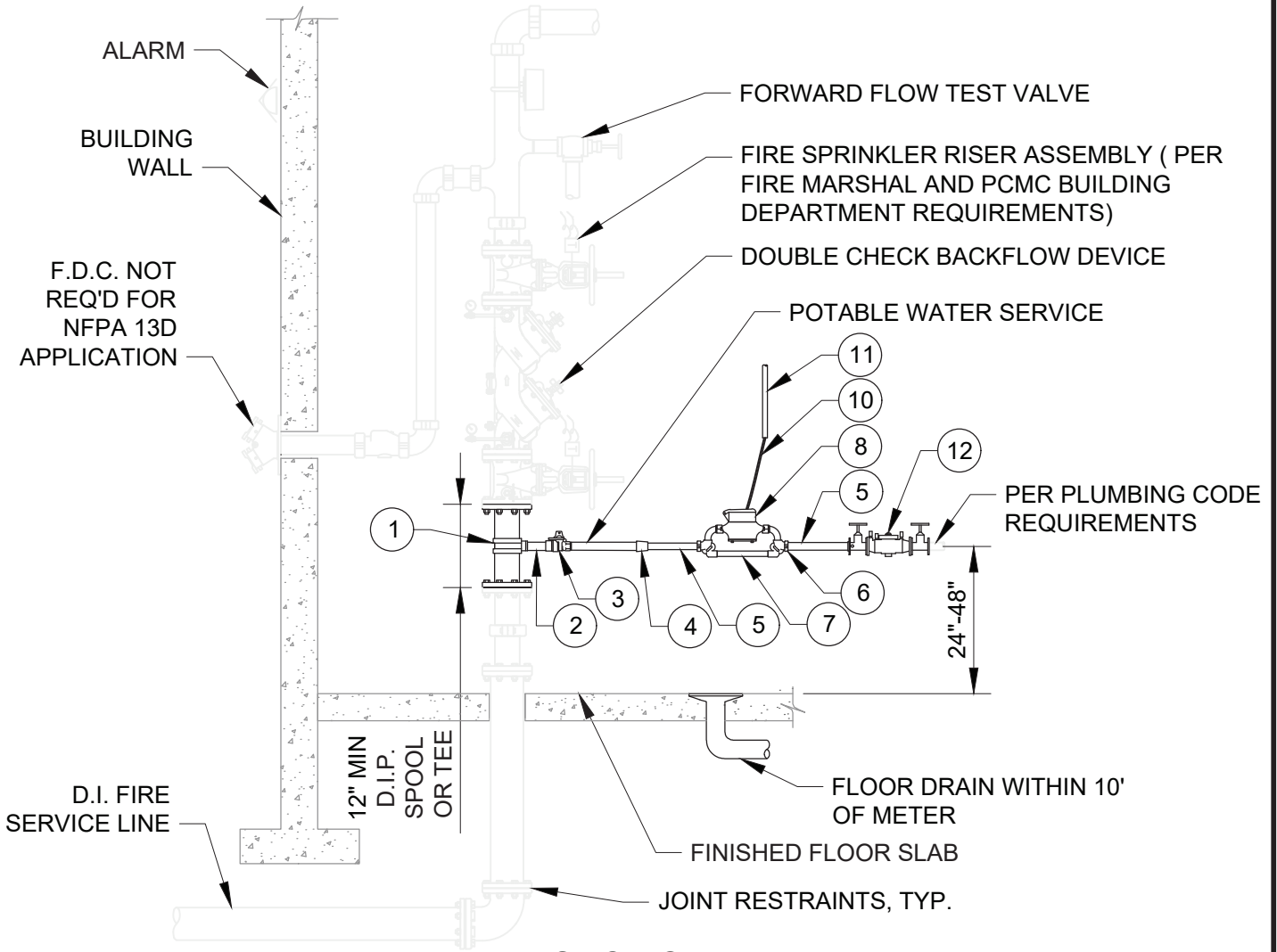

SECTION
NTS

NOTES:

1. REFER TO STD. PLAN 520 FOR GENERAL REQUIREMENTS - METER, METER VAULT, AND SERVICE LINE.
2. REFER TO STD. PLAN 523 S FOR LEGEND ITEMS, APPROVED PARTS LIST, AND DETAIL NOTES.

 PARK CITY MUNICIPAL CORPORATION WATER	DATE	3/4" AND 1" METER INSIDE SETTING	STD. PLAN
	03/2024		523
	REV.		
	1		

LEGEND AND APPROVED PARTS LIST

ITEM	DESCRIPTION	ACCEPTABLE MANUFACTURER	MODELS
①	1" BRONZE SERVICE SADDLE, DOUBLE STRAP	MUELLER	BR2B SERIES, CC THREADS
		FORD	STYLE 202B, CC THREADS
②	1" DIA. BRASS NIPPLE x 2" LENGTH, M.I.P.		
③	1" CURB VALVE, F.I.P. X F.I.P.	MUELLER	B-20283N
④	1" DIA. BRASS NIPPLE x 2" LENGTH, M.I.P. AND BRONZE BELL REDUCER, 1" X 3/4" DIA. (REQ'D FOR 3/4" METER YOKE ONLY)		
⑤	3/4" OR 1" DIA. COPPER PIPING AND FITTINGS, AS REQ'D PER SITE SPECIFIC LAYOUT		
⑥	3/4" OR 1" METER YOKE END CONNECTIONS	MUELLER	MULTI X F.I.P, H-14222N
⑦	3/4" METER YOKE (HORIZONTAL LINE INLET AND OUTLET)	MUELLER	5/8"x3/4" B-2518-2AN
		FORD	5/8"x3/4" LSVBHCR11-233W-NL
	3/4" METER YOKE (VERTICAL INLET AND OUTLET)	MUELLER	5/8"x3/4" B-2448-2AN
		FORD	5/8"X3/4" KHVBHCr-2-NL
	1" METER YOKE (HORIZONTAL LINE INLET AND OUTLET)	MUELLER	1" B-2518-2AN
		FORD	1" LSVBHH11-444W-NL
	1" METER YOKE (VERTICAL INLET AND OUTLET)	MUELLER	1" B-2448-2AN
		FORD	1" KHVBHCR-4-NL
⑧	METER, SUPPLIED AND INSTALLED BY PCMC	SENSUS	iPEARL
⑨	PIPE SIZE BRASS NIPPLE AND CURB VALVE, F.I.P. X F.I.P.	MUELLER	B-20283N
⑩	MXU AND WIRING, SUPPLIED AND INSTALLED BY PCMC		
⑪	EMT CONDUIT FOR MXU WIRING, AS REQUIRED		
⑫	DOUBLE CHECK BACKFLOW ASSEMBLY		



PARK CITY MUNICIPAL CORPORATION
WATER

DATE

05/2025

REV.

3

**3/4" AND 1" METER
INSIDE SETTING**

STD. PLAN

523 S.1

DETAIL NOTES

1. USE OF AN INSIDE WATER METER REQUIRES PUBLIC UTILITIES ENGINEER APPROVAL. REFERENCE WATER STANDARD PLAN 520 FOR APPLICABLE CONDITIONS.
2. FIRE SPRINKLER RISER WITH POTABLE WATER SERVICE: A SITE SPECIFIC DESIGN IS REQUIRED. THE FIRE PROTECTION SPRINKLER SYSTEM AND POTABLE WATER SYSTEM DESIGN SHALL BE APPROVED BY THE FIRE MARSHAL AND THE PARK CITY BUILDING DEPARTMENT. THE POTABLE WATER SERVICE CONNECTION AND METER ASSEMBLY DESIGN SHALL BE APPROVED BY THE PARK CITY BUILDING DEPARTMENT AND THE PUBLIC UTILITIES ENGINEER. DESIGN AND CONSTRUCTION SHALL COMPLY WITH APPLICABLE BUILDING AND PLUMBING CODES.
3. BACKFLOW PREVENTION: PROVIDE A DOUBLE CHECK BACKFLOW ASSEMBLY (DC) ON THE FIRE SPRINKLER RISER ASSEMBLY. REDUCED PRESSURE PRINCIPLE BACKFLOW ASSEMBLY (RP) ALLOWED WITH PUBLIC UTILITIES ENGINEER APPROVAL. STYLE TO BE DETERMINED BY THE BUILDING AND WATER DEPARTMENT BASED ON DEGREE OF HAZARD POSED BY FIRE SPRINKLER PROTECTION SYSTEM. BEFORE A CERTIFICATE OF OCCUPANCY CAN BE ISSUED BY THE BUILDING DEPARTMENT, BACKFLOW ASSEMBLY TESTING FOR PROPER OPERATION (PER CITY REQUIREMENTS BY A CERTIFIED TESTER RECOGNIZED BY THE CITY) IS REQUIRED AND A REPORT SUBMITTED.
4. CONNECTIONS TO THE WATER SYSTEM ARE NOT PERMITTED PRIOR TO THE POTABLE WATER METER ASSEMBLY OR THE FIRE SPRINKLER RISER BACKFLOW ASSEMBLY. THIS INCLUDES OUTSIDE IRRIGATION SUPPLY.
5. CLEARANCES: PROVIDE ADEQUATE CLEARANCES FROM FIRE RISER AND AROUND WATER METER ASSEMBLY. MAINTAIN:
 - 9" MINIMUM FROM WALL TO FACE OF POTABLE WATER PIPING
 - 18" CLEAR ON EACH SIDE OF METER ASSEMBLY
 - 36" CLEAR IN FRONT OF METER ASSEMBLY
6. LOCATE METER ASSEMBLY TWO (2) TO FOUR (4) FEET ABOVE THE FLOOR. POSITION METER HORIZONTAL WITH DIAL POINTING UP.
7. PROVIDE ISOLATION (CURB) VALVES AT METER INLET AND OUTLET
8. FOR MULTIPLE METERS PROVIDE A MANIFOLD WITH A MAIN CURB VALVE PRIOR TO THE MANIFOLD AND INDIVIDUAL CURB VALVES LOCATED PRIOR TO AND AFTER METERS.
9. PROVIDE A FLOOR DRAIN IN THE FIRE RISER ROOM WITHIN 10 FEET OF THE WATER METER LOCATION.
10. PROVIDE PIPE LABELS ON THE POTABLE WATER LINE BETWEEN THE FIRE RISER AND THE WATER METER DESIGNATING PIPE AS "POTABLE WATER".
11. PROVIDE PIPE ANCHORAGE TO SUPPORT METER YOKE AND ASSEMBLY INDEPENDENT OF THE POTABLE WATER SUPPLY PIPING AND BUILDING PLUMBING. PROVIDE PIPE STANDS OR UNISTRUT WALL STANDOFFS. DO NOT SUPPORT METER ASSEMBLY FROM OTHER PIPING.
12. PROVIDE A WALL PENETRATION AND CONDUIT FOR REMOTE RADIOREAD METER TRANSEIVER UNIT (MXU) DEVICE(S). COORDINATE ROUTING AND WALL PENETRATION LOCATION WITH THE WATER DEPARTMENT. REFERENCE WATER STANDARD PLANS 520 AND 530.
13. PROVIDE 1/2" EMT CONDUIT AND SUPPORTS FOR MXU SIGNAL WIRE IF DISTANCE TO WALL PENETRATION EXCEEDS 10 FEET
14. INSPECTION: CONTACT THE CITY ENGINEER FOR INSPECTION OF THE POTABLE WATER SYSTEM METER ASSEMBLY INSTALLATION
15. REFER TO STD. PLAN 500 AND THE SPECIFICATIONS FOR FLUSHING, HYDROSTATIC TESTING, AND DISINFECTING REQUIREMENTS

 PARK CITY MUNICIPAL CORPORATION WATER	DATE	3/4" AND 1" METER INSIDE SETTING	STD. PLAN
	05/2025		523 S.2
	REV.		
	3		

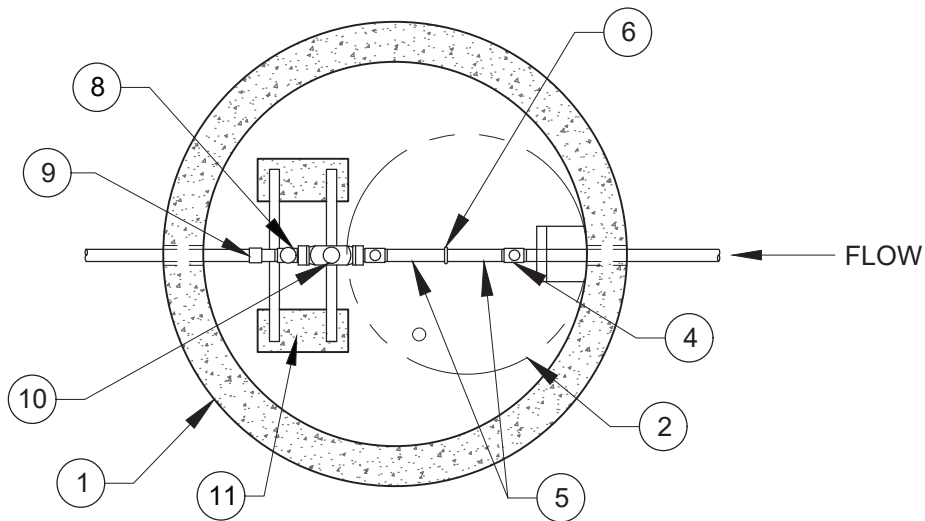

PLAN
NTS

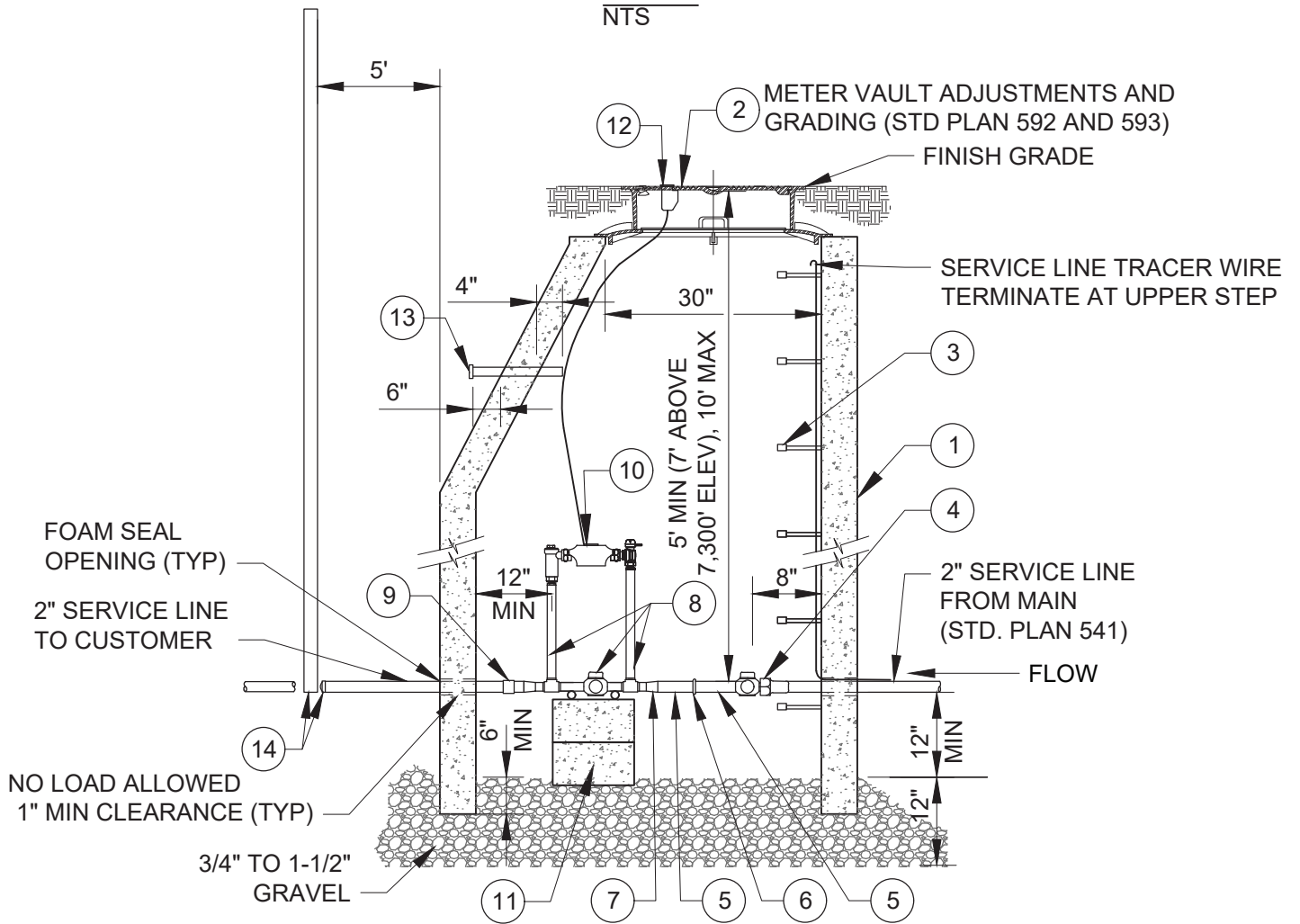

SECTION
NTS

NOTES:

1. REFER TO STD. PLAN 520 FOR GENERAL REQUIREMENTS - METER, METER VAULT, AND SERVICE LINE.
2. REFER TO STD. PLAN 524 S FOR LEGEND ITEMS, APPROVED PARTS LIST, AND DETAIL NOTES.

 PARK CITY MUNICIPAL CORPORATION WATER	DATE	1-1/2" AND 2" SINGLE METER OUTSIDE SETTING	STD. PLAN
	05/2014		524
	REV.		
	0		

LEGEND AND APPROVED PARTS LIST

ITEM	DESCRIPTION	ACCEPTABLE MANUFACTURER	MODELS
①	5' DIA. MANHOLE, PRECAST CONCRETE ECCENTRIC CONE AND WALL SECTIONS		ASTM C 478
②	METER VAULT FRAME AND COVER (STD. PLAN 529)		
③	POLYPROPYLENE ENCASED GRADE 60 STEEL STEPS AT 13" C-C, 13-1/2" TREAD WIDTH	M.A. INDUSTRIES OR APPV'D EQ.	PS2-PFDF
④	2" CURB VALVE, F.I.P. x CTS	MUELLER	B-25172N
		FORD	B11-777Q
⑤	2" DIA. BRASS NIPPLE x 4" LENGTH, M.I.P.		
⑥	2" BRONZE UNION, F.I.P., THREADED		
⑦	1-1/2" METER YOKE 2" BRASS NIPPLE x 4" LENGTH, 2" x 1-1/2" BRONZE BELL REDUCER, AND 1-1/2" CLOSE BRASS NIPPLE		
	2" METER YOKE 2" BRASS NIPPLE x 4" LENGTH		
⑧	1-1/2" METER YOKE COMMERCIAL SERVICE: WITH BYPASS RESIDENTIAL SERVICE: WITHOUT BYPASS IRRIGATION SERVICE: WITHOUT BYPASS <u>METER LAY LENGTH – 13 INCHES</u>	MUELLER	1-1/2"x18" B-1423-2-01N (WITH BYPASS) 1-1/2"x18" B-2422-2N (W/O BYPASS)
		FORD	1-1/2" VBHC76-18B-11-66-NL (WITH BYPASS) 1-1/2" VBHC76-18-11-66-NL (W/O BYPASS)
	2" METER YOKE COMMERCIAL SERVICE: WITH BYPASS RESIDENTIAL SERVICE: WITHOUT BYPASS IRRIGATION SERVICE: WITHOUT BYPASS <u>METER LAY LENGTH – 17 INCHES</u>	MUELLER	2"x18" B-1423-2-01N (WITH BYPASS) 2"x18" B-2422-2N (W/O BYPASS)
		FORD	2" VBHC77-18B-11-77-NL (WITH BYPASS) 2" VBHC77-18-11-77-NL (W/O BYPASS)
⑨	1-1/2" METER YOKE F.I.P x CTS AND 2" BRASS NIPPLE x 4" LENGTH, 2" x 1-1/2" BRONZE BELL REDUCER, AND 1-1/2" CLOSE BRASS NIPPLE	MUELLER	H-15451N
		FORD	C-14-66-G-NL
⑨	2" METER YOKE F.I.P x CTS AND 2" BRASS NIPPLE x 4" LENGTH		
⑩	METER, SUPPLIED AND INSTALLED BY PCMC	SENSUS	OMNI
⑪	PIPE SUPPORTS (4) 16"x8"x8" CMU BLOCK, (2) METER SUPPORT RODS, GALVANIZED		
⑫	MXU AND WIRING, SUPPLIED AND INSTALLED BY PCMC		
⑬	MXU REMOTE LOCATION CONDUIT WITH END CAPS, SCH 40 PVC (STD. PLAN 531)		
⑭	END CAP AND MARKER, CTS x F.I.P. (OUTLET)		H-15451N AND H-10035N

DETAIL NOTES

1. LOCATE METER VAULT PER APPROVED PLANS AND SET METER BOX PLUMB
2. SST INSERT STIFFENERS REQUIRED ON ALL CTS TUBING CONNECTIONS

 PARK CITY MUNICIPAL CORPORATION WATER	DATE	1-1/2" AND 2" SINGLE METER OUTSIDE SETTING	STD. PLAN
	03/2024		524 S
	REV.		
	2		

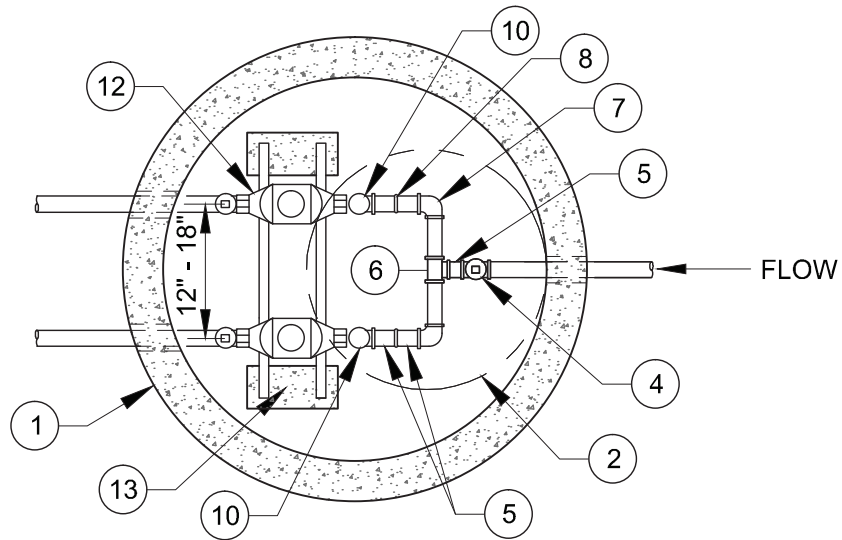

PLAN
NTS

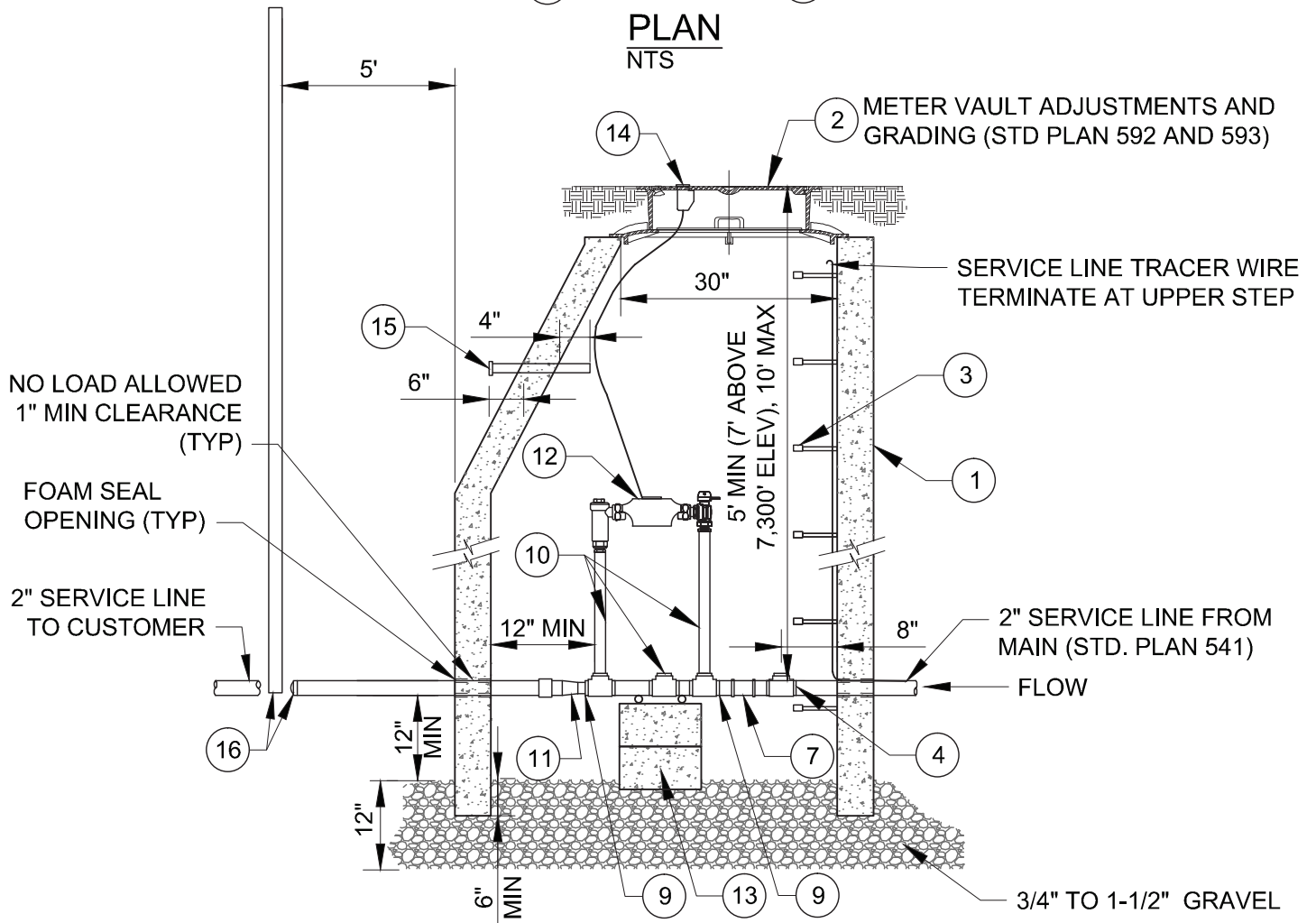

SECTION
NTS

NOTES:

1. REFER TO STD. PLAN 520 FOR GENERAL REQUIREMENTS - METER, METER VAULT, AND SERVICE LINE.
2. REFER TO STD. PLAN 525 S FOR LEGEND ITEMS, APPROVED PARTS LIST, AND DETAIL NOTES.

 PARK CITY MUNICIPAL CORPORATION WATER	DATE	1-1/2" DUAL METERS OUTSIDE SETTING	STD. PLAN
	05/2014		525
	REV.		
	0		

LEGEND AND APPROVED PARTS LIST

ITEM	DESCRIPTION	ACCEPTABLE MANUFACTURER	MODELS
①	5' DIA. MANHOLE, PRECAST CONCRETE ECCENTRIC CONE AND WALL SECTIONS		ASTM C 478
②	METER VAULT FRAME AND COVER (STD. PLAN 529)		
③	POLYPROPYLENE ENCASED GRADE 60 STEEL STEPS AT 13" C-C, 13-1/2" TREAD WIDTH	M.A. INDUSTRIES OR APPV'D EQ.	PS2-PFDF
④	2" CURB VALVE, F.I.P. x CTS	MUELLER	B-25172N
		FORD	B11-777Q
⑤	2" DIA. BRASS NIPPLE x 3" LENGTH, M.I.P. (5 EA)		
⑥	2" DIA. BRONZE TEE, F.I.P., THREADED		
⑦	2" BRONZE 90° ELBOW, F.I.P., THREADED (2 EA)		
⑧	2" BRONZE UNION, F.I.P., THREADED (2 EA)		
⑨	1-1/2" BRASS NIPPLE x 4" LENGTH, 2" x 1-1/2" BRONZE BELL REDUCER, AND 1-1/2" CLOSE BRASS NIPPLE (2 EA)		
⑩	1-1/2" METER YOKE (2 EA) COMMERCIAL SERVICE: WITH BYPASS RESIDENTIAL SERVICE: WITHOUT BYPASS IRRIGATION SERVICE: WITHOUT BYPASS <u>METER LAY LENGTH – 13 INCHES</u>	MUELLER	1-1/2"x18" B-1423-2-01N (WITH BYPASS) 1-1/2"x18" B-2422N (WITHOUT BYPASS)
		FORD	1-1/2" VBHC76-18B-11-66-NL (WITH BYPASS) 1-1/2" VBHC76-18-11-66-NL (WITHOUT BYPASS)
⑪	2" CONNECTION, F.I.P. x CTS; 2" BRASS NIPPLE x 4" LENGTH; 2"x1-1/2" BRONZE BELL REDUCER; AND 1-1/2" CLOSE BRASS NIPPLE (OUTLET) (2 EA)	MUELLER	H-15451N
		FORD	C-14-66-G-NL
⑫	METER, SUPPLIED AND INSTALLED BY PCMC (2 EA)	SENSUS	OMNI
⑬	PIPE SUPPORTS (4) 16"X8"X8" CMU BLOCK, (2) METER SUPPORT RODS, GALVANIZED		
⑭	MXU AND WIRING, SUPPLIED AND INSTALLED BY PCMC		
⑮	MXU REMOTE LOCATION CONDUIT WITH END CAPS, SCH 40 PVC (STD. PLAN 531)		
⑯	END CAP AND MARKER, CTS X F.I.P. (OUTLET) (2 EA)		H-15451N AND H-10035N

DETAIL NOTES

1. LOCATE METER VAULT PER APPROVED PLANS AND SET METER BOX PLUMB
2. SST INSERT STIFFENERS REQUIRED ON ALL CTS TUBING CONNECTIONS

 PARK CITY MUNICIPAL CORPORATION WATER	DATE	1-1/2" DUAL METERS OUTSIDE SETTING	STD. PLAN
	03/2024		525 S
	REV.		
	2		

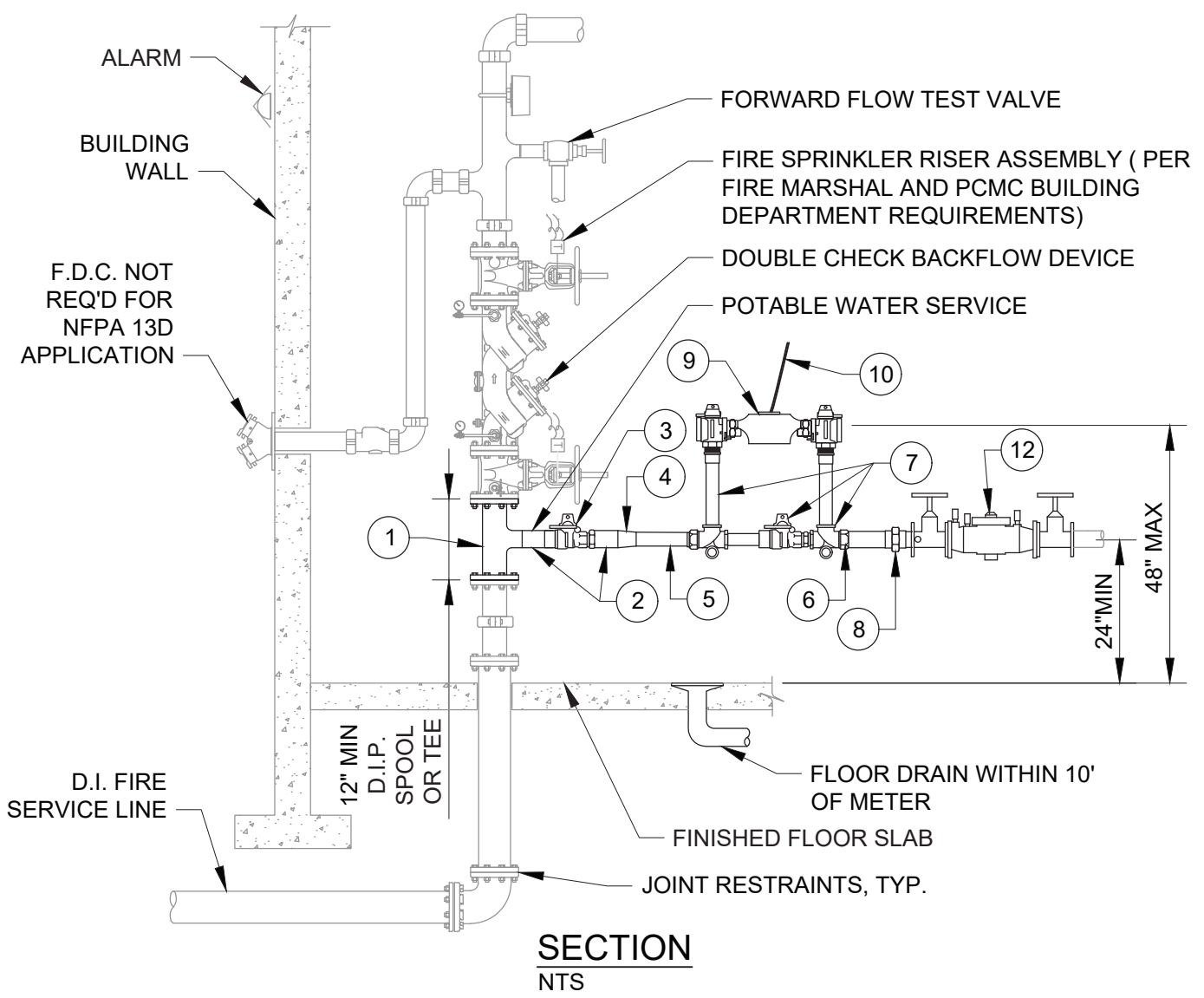
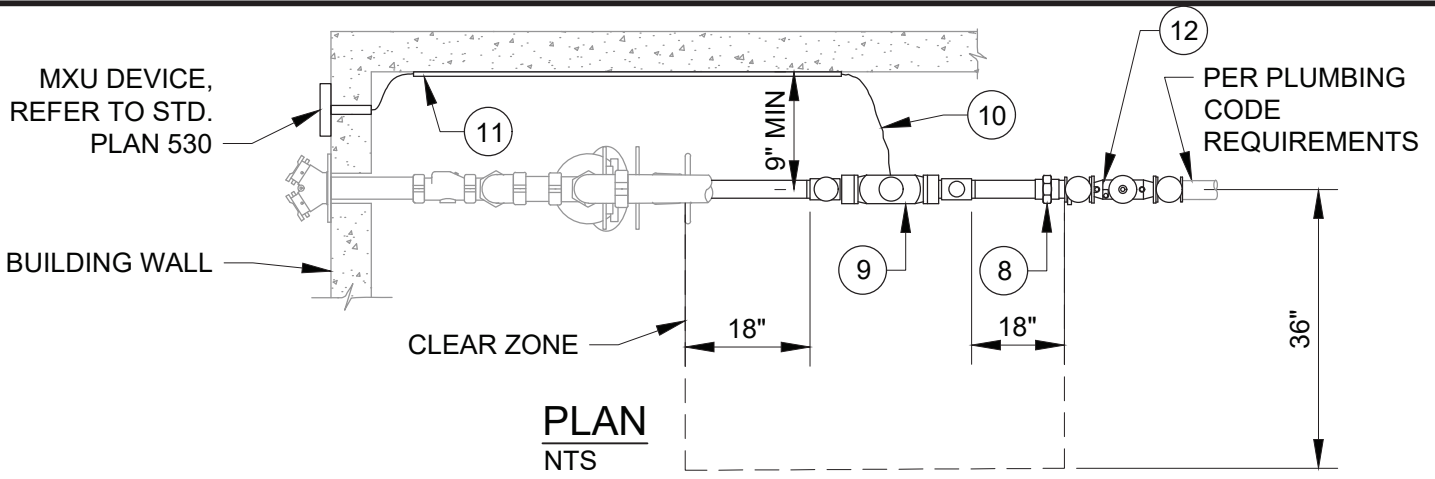

NOTES:

1. REFER TO STD. PLAN 520 FOR GENERAL REQUIREMENTS - METER, METER VAULT, AND SERVICE LINE.
2. REFER TO STD. PLAN 526 S FOR LEGEND ITEMS, APPROVED PARTS LIST, AND DETAIL NOTES.

 PARK CITY MUNICIPAL CORPORATION WATER	DATE	1-1/2" AND 2" METER INSIDE SETTING	STD. PLAN
	03/2024		526
	REV.		
	1		

LEGEND AND APPROVED PARTS LIST

ITEM	DESCRIPTION	ACCEPTABLE MANUFACTURER	MODELS
①	DUCTILE IRON TEE OR 2" BRONZE SERVICE SADDLE, DOUBLE STRAP	MUELLER	BR2B SERIES, FIP THDS
		FORD	STYLE 202B, FIP THDS
②	2" DIA. BRASS NIPPLE x 2" LENGTH, M.I.P.		
③	2" CURB VALVE, F.I.P. X F.I.P.	MUELLER	B-20283N
		FORD	B11-777Q
④	2" DIA. BRASS NIPPLE x 2" LENGTH, M.I.P. AND BRONZE BELL REDUCER, 2" X 1-1/2" DIA. (REQ'D FOR 1-1/2" YOKE ONLY)		
⑤	1-1/2" OR 2" DIA. BRASS NIPPLES AND BRASS FITTINGS OR COPPER PIPING AND FITTINGS, AS REQ'D PER SITE SPECIFIC LAYOUT		
⑥	1-1/2" OR 2" METER YOKE END CONNECTIONS	MUELLER	MULTI X F.I.P., H-14222N
⑦	1-1/2" METER YOKE COMMERCIAL SERVICE: WITH BYPASS RESIDENTIAL SERVICE: WITHOUT BYPASS <u>METER LAY LENGTH – 13 INCHES</u>	MUELLER	1-1/2"x12" B-2423N (WITH BYPASS) 1-1/2"x12" B-2422-00N (WITHOUT BYPASS)
		FORD	1-1/2" VBB76-18B-11-66-NL (WITH BYPASS) 1-1/2" VBB76-18-11-66-NL (WITHOUT BYPASS)
	2" METER YOKE COMMERCIAL SERVICE: WITH BYPASS RESIDENTIAL SERVICE: WITHOUT BYPASS <u>METER LAY LENGTH – 17 INCHES</u>	MUELLER	2"x12" B-2423N (WITH BYPASS) 2"x12" B-2422-00N (WITHOUT BYPASS)
		FORD	2" VBB77-12B-11-77-NL (WITH BYPASS) 2" VBB77-12-11-77-NL (WITHOUT BYPASS)
⑧	PIPE SIZE BRASS NIPPLE AND BRONZE UNION, F.I.P., THREADED		
⑨	METER, SUPPLIED AND INSTALLED BY PCMC	SENSUS	OMNI
⑩	MXU AND WIRING, SUPPLIED AND INSTALLED BY PCMC		
⑪	EMT CONDUIT FOR MXU WIRING, AS REQUIRED		
⑫	DOUBLE CHECK BACKFLOW ASSEMBLY		



PARK CITY MUNICIPAL CORPORATION
WATER

DATE

05/2025

REV.

3

**1-1/2" AND 2" METER
INSIDE SETTING**

STD. PLAN

526 S.1

DETAIL NOTES

1. USE OF AN INSIDE WATER METER REQUIRES PUBLIC UTILITIES ENGINEER APPROVAL. REFERENCE WATER STANDARD PLAN 520 FOR APPLICABLE CONDITIONS.
2. FIRE SPRINKLER RISER WITH POTABLE WATER SERVICE: A SITE SPECIFIC DESIGN IS REQUIRED. THE FIRE PROTECTION SPRINKLER SYSTEM AND POTABLE WATER SYSTEM DESIGN SHALL BE APPROVED BY THE FIRE MARSHAL AND THE PARK CITY BUILDING DEPARTMENT. THE POTABLE WATER SERVICE CONNECTION AND METER ASSEMBLY DESIGN SHALL BE APPROVED BY THE PARK CITY BUILDING DEPARTMENT AND THE PUBLIC UTILITIES ENGINEER. DESIGN AND CONSTRUCTION SHALL COMPLY WITH APPLICABLE BUILDING AND PLUMBING CODES.
3. BACKFLOW PREVENTION: PROVIDE A DOUBLE CHECK BACKFLOW ASSEMBLY (DC) ON THE FIRE SPRINKLER RISER ASSEMBLY. REDUCED PRESSURE PRINCIPLE BACKFLOW ASSEMBLY (RP) ALLOWED WITH PUBLIC UTILITIES ENGINEER APPROVAL. STYLE TO BE DETERMINED BY THE BUILDING AND WATER DEPARTMENT BASED ON DEGREE OF HAZARD POSED BY FIRE SPRINKLER PROTECTION SYSTEM. BEFORE A CERTIFICATE OF OCCUPANCY CAN BE ISSUED BY THE BUILDING DEPARTMENT, BACKFLOW ASSEMBLY TESTING FOR PROPER OPERATION (PER CITY REQUIREMENTS BY A CERTIFIED TESTER RECOGNIZED BY THE CITY) IS REQUIRED AND A REPORT SUBMITTED.
4. CONNECTIONS TO THE WATER SYSTEM ARE NOT PERMITTED PRIOR TO THE POTABLE WATER METER ASSEMBLY OR THE FIRE SPRINKLER RISER BACKFLOW ASSEMBLY. THIS INCLUDES OUTSIDE IRRIGATION SUPPLY.
5. CLEARANCES: PROVIDE ADEQUATE CLEARANCES FROM FIRE RISER AND AROUND WATER METER ASSEMBLY. MAINTAIN: 9" MINIMUM FROM WALL TO FACE OF POTABLE WATER PIPING
18" CLEAR ON EACH SIDE OF METER ASSEMBLY
36" CLEAR IN FRONT OF METER ASSEMBLY
6. LOCATE METER ASSEMBLY TWO (2) TO FOUR (4) FEET ABOVE THE FLOOR. POSITION METER HORIZONTAL WITH DIAL POINTING UP.
7. PROVIDE ISOLATION (CURB) VALVES AT METER INLET AND OUTLET
8. FOR MULTIPLE METERS PROVIDE A MANIFOLD WITH A MAIN CURB VALVE PRIOR TO THE MANIFOLD AND INDIVIDUAL CURB VALVES LOCATED PRIOR TO AND AFTER METERS.
9. PROVIDE A FLOOR DRAIN IN THE FIRE RISER ROOM WITHIN 10 FEET OF THE WATER METER LOCATION.
10. PROVIDE PIPE LABELS ON THE POTABLE WATER LINE BETWEEN THE FIRE RISER AND THE WATER METER DESIGNATING PIPE AS "POTABLE WATER".
11. PROVIDE PIPE ANCHORAGE TO SUPPORT METER YOKE AND ASSEMBLY INDEPENDENT OF THE POTABLE WATER SUPPLY PIPING AND BUILDING PLUMBING. PROVIDE PIPE STANDS OR UNISTRUT WALL STANDOFFS. DO NOT SUPPORT METER ASSEMBLY FROM OTHER PIPING.
12. PROVIDE A WALL PENETRATION AND CONDUIT FOR REMOTE RADIOREAD METER TRANSEIVER UNIT (MXU) DEVICE(S). COORDINATE ROUTING AND WALL PENETRATION LOCATION WITH THE WATER DEPARTMENT. REFER TO WATER STANDARD PLANS 520 AND 530.
13. PROVIDE 1/2" EMT CONDUIT AND SUPPORTS FOR MXU SIGNAL WIRE IF DISTANCE TO WALL PENETRATION EXCEEDS 10 FEET.
14. INSPECTION: CONTACT THE CITY ENGINEER FOR INSPECTION OF THE POTABLE WATER SYSTEM METER ASSEMBLY INSTALLATION
15. REFER TO STD. PLAN 500 AND THE SPECIFICATIONS FOR FLUSHING, HYDROSTATIC TESTING, AND DISINFECTING REQUIREMENTS

 PARK CITY MUNICIPAL CORPORATION WATER	DATE	1-1/2" AND 2" METER INSIDE SETTING	STD. PLAN
	05/2025		526 S.2
	REV.		
	3		

9'-0" MINIMUM, LONGER VAULT SHALL BE PROVIDED AS REQUIRED TO INCLUDE ALL COMPONENTS AND CLEARANCES

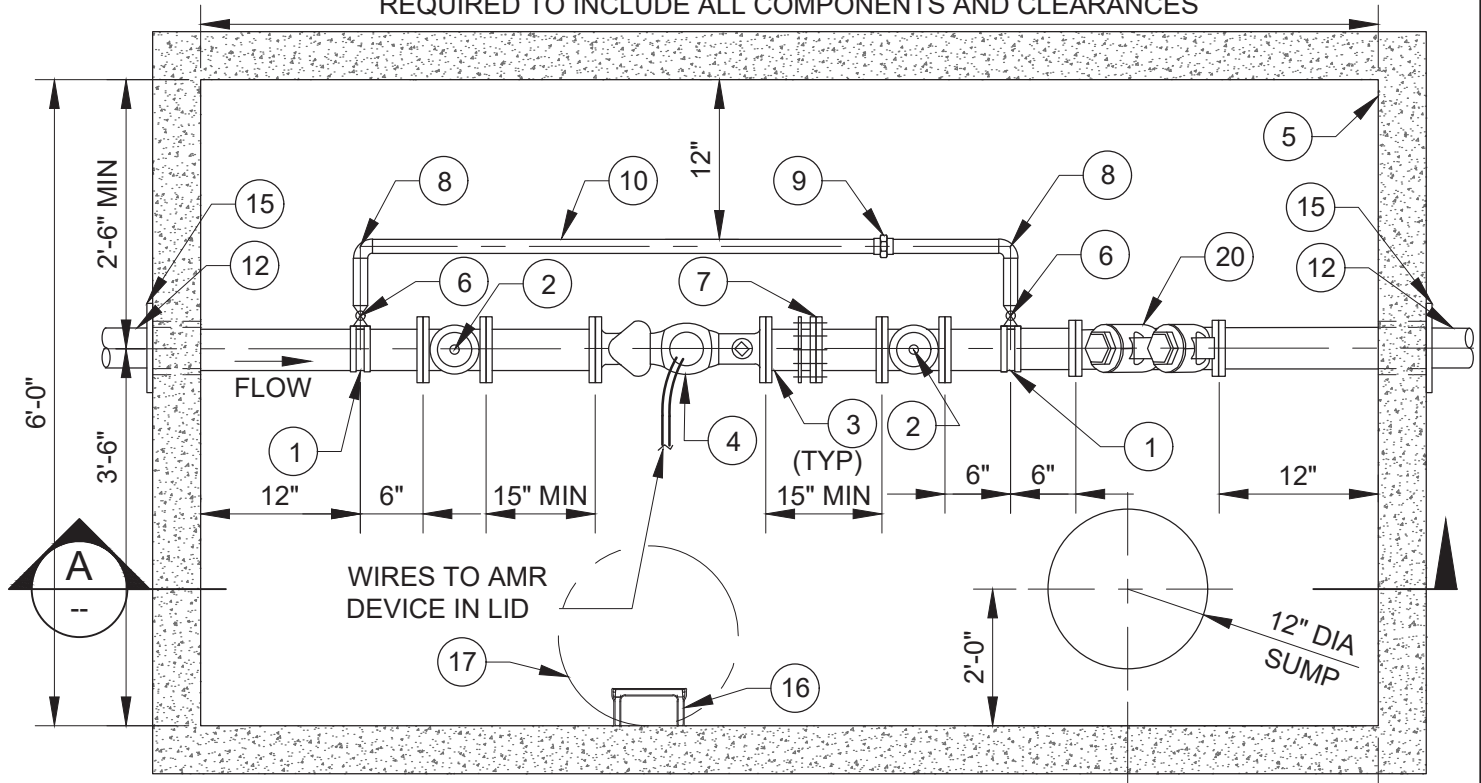

PLAN
NTS

WATERMAIN
SIDE

CUSTOMER
SIDE

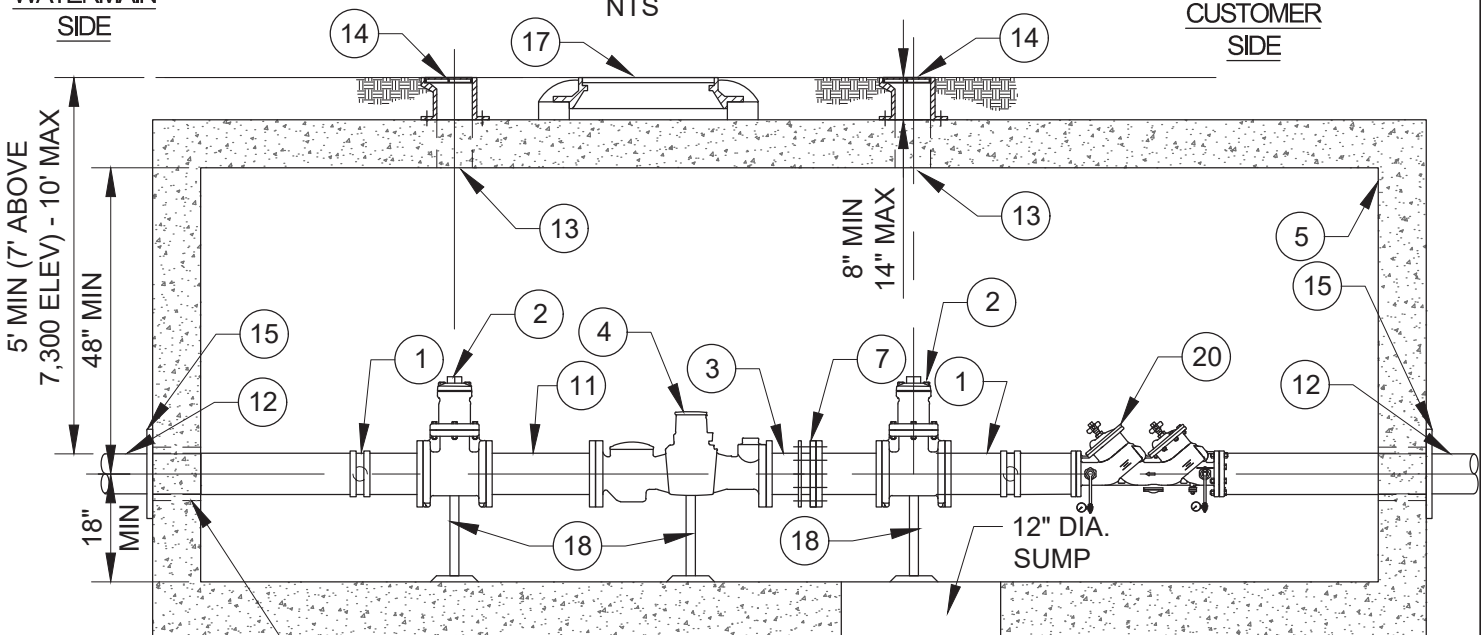

SECTION
NTS

DRILLED OR
PRECAST WALL
PENETRATION WITH
LINK SEAL (TYP)

3/4" TO 1 1/2" CLEAN GRAVEL
12" MIN THICKNESS

NOTES:

1. REFER TO STD. PLAN 520 FOR GENERAL REQUIREMENTS - METER, METER VAULT, AND SERVICE LINE.
2. REFER TO STD. PLAN 527 S FOR LEGEND ITEMS, APPROVED PARTS LIST, AND DETAIL NOTES.

 PARK CITY MUNICIPAL CORPORATION WATER	DATE	3" AND LARGER METER OUTSIDE SETTING	STD. PLAN
	05/2025		527
	REV.		
	2		

LEGEND AND APPROVED PARTS LIST

ITEM	DESCRIPTION	ACCEPTABLE MANUFACTURER	MODELS
①	2" BRONZE SERVICE SADDLE, DOUBLE STRAP	MUELLER	BR2B SERIES, F.I.P. THREADS
		FORD	202B SERIES, F.I.P. THREADS
②	GATE VALVE, PIPE SIZE, NRS, FLANGED, 2" SQ. OPERATING NUT, AWWA C509	MUELLER	SERIES A-2360
		CLOW	MODEL 2639
③	DUCTILE IRON PIPE SPOOL (2), FLG X PE 15"		
④	METER, SUPPLIED AND INSTALLED BY PCMC	SENSUS	OMNI
⑤	PRECAST CONCRETE VAULT, HS20 RATED		
⑥	2" BRONZE BALL VALVE WITH LOCKING HANDLE, F.I.P., THREADED, 300 PSI RATED	FORD	B11-777Q
⑦	DISMANTLING JOINT	ROMAC	DJ400 OR APPV'D EQUAL
⑧	2" DIA. COPPER 90° ELBOW, SOLDERED, OR BRONZE, F.I.P., THREADED		
⑨	2" DIA. BRONZE UNION, F.I.P., THREADED		
⑩	2" COPPER PIPE, TYPE K, OR BRASS NIPPLE		
⑪	DUCTILE IRON PIPE SPOOL, 15" LENGTH, FLG X FLG		
⑫	DUCTILE IRON PIPE SPOOL, FLG X PE		
⑬	AFTER PIPING INSTALLATION CORE DRILL 6" DIA. HOLE IN VAULT LID DIRECTLY ABOVE GATE VALVES		
⑭	VALVE BOX, FASTEN VALVE BOX TO VAULT WITH TWO EPOXIED ALL-THREAD ROD/NUT OR SST EXP ANCHOR	D & L SUPPLY HILTI	M-8065 AND M-8048 TO M-8053 3/8" DIA. ROD SST 316, OR KWIK BOLT 3 3/8"x3" SS316
⑮	THRUST RESTRAINTS	EBBA IRON	MEGALUG SERIES 1100
⑯	POLYPROPYLENE ENCASED GRADE 60 STL STEPS AT 13" C-C, 13-1/2" TREAD WIDTH	M.A. INDUSTRIES OR APPV'D EQUAL	PS2-PDFD
⑰	METER VAULT FRAME AND COVER (STD. PLAN 529)		
⑱	PIPE SUPPORTS, 5 REQ'D (STD. PLAN 533)		
⑲	MXU AND WIRING, SUPPLIED AND INSTALLED BY PCMC		
⑳	SWING CHECK BACKFLOW ASSEMBLY	VAL-MATIC	W/ BACKFLOW ACTUATOR

DETAIL NOTES

1. REFER TO STD. PLAN 520 FOR GENERAL REQUIREMENTS – METER, METER VAULT, AND SERVICE LINE
2. LOCATE METER VAULT PER APPROVED PLANS AND SET METER BOX PLUMB
3. SST FASTENERS REQUIRED ON ALL FITTINGS
4. NO BYPASS ALLOWED FOR IRRIGATION METERS
5. NO SERVICE LINE REDUCERS OR BENDS WITHIN 5' OF VAULT
6. COORDINATE METER SIZE AND LENGTH WITH CITY PRIOR TO ORDERING MATERIALS
7. REFER TO STD. PLANS 592 AND 593 FOR MANHOLE ADJUSTMENT AND GRADING REQUIREMENTS
8. FOR 3" METERS A MINIMUM OF 4" PIPE SHALL BE USED AND REDUCED AT METER, ALL OTHER PIPE SIZE SHOULD MATCH METER SIZE.

 PARK CITY MUNICIPAL CORPORATION WATER	DATE	<h2 style="margin: 0;">3" AND LARGER METER OUTSIDE SETTING</h2>	STD. PLAN
	05/2025		527 S
	REV.		
	3		

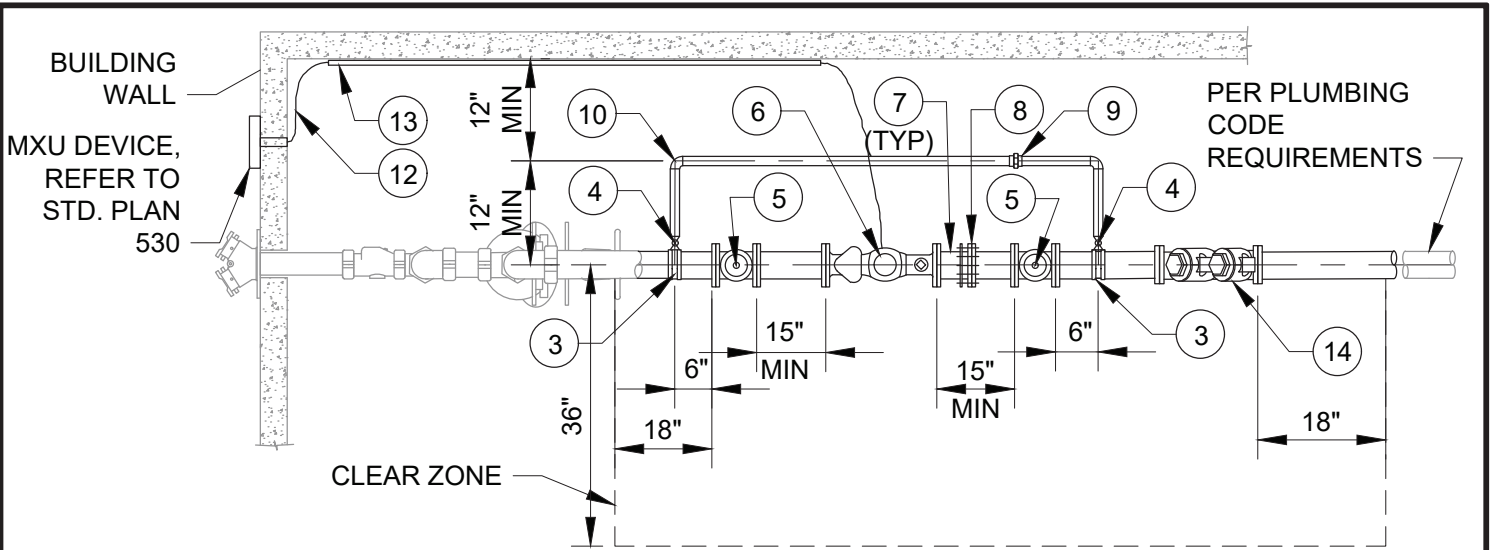

PLAN
NTS

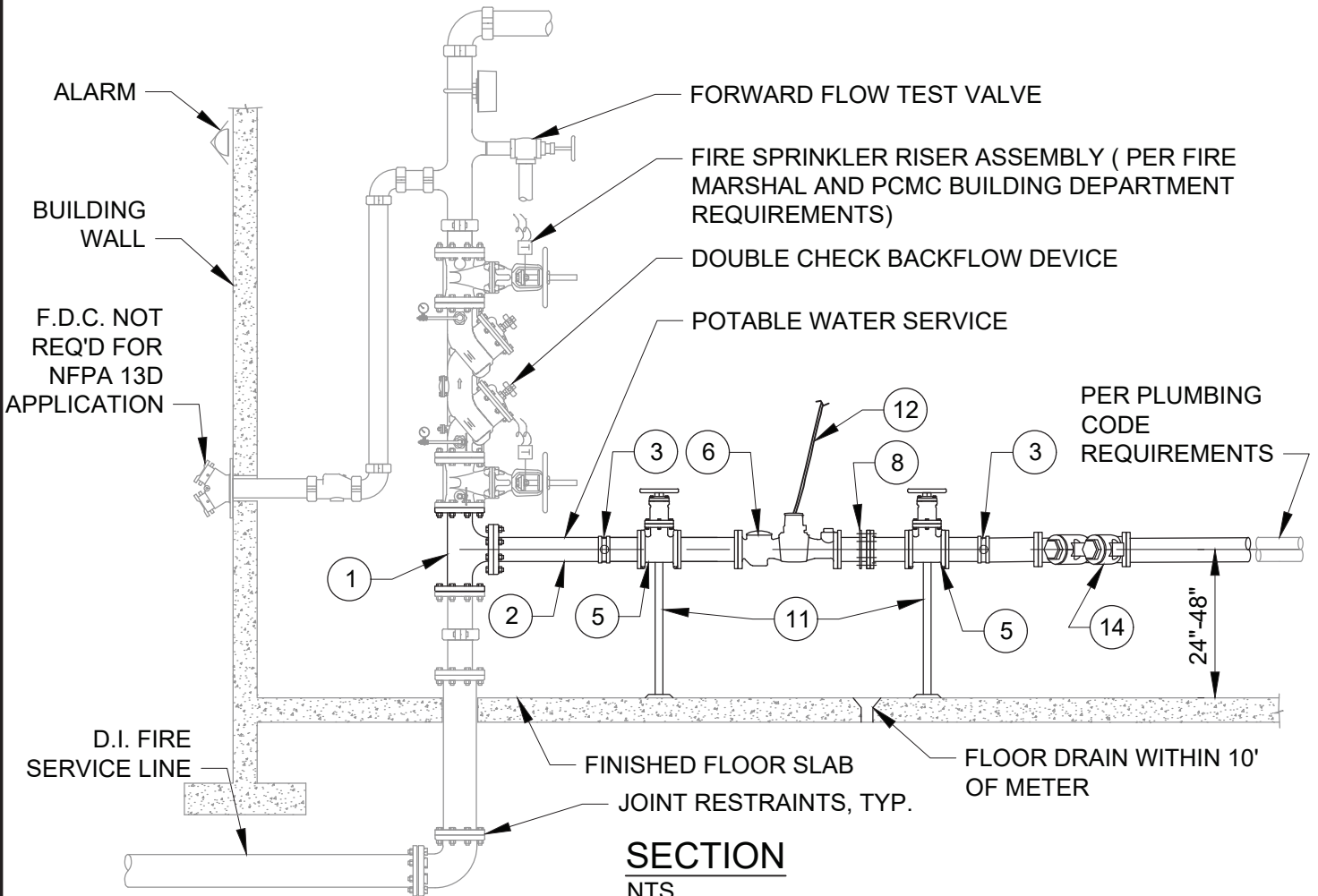

SECTION
NTS

NOTES:

1. REFER TO STD. PLAN 520 FOR GENERAL REQUIREMENTS - METER, METER VAULT, AND SERVICE LINE.
2. REFER TO STD. PLAN 528 S FOR LEGEND ITEMS, APPROVED PARTS LIST, AND DETAIL NOTES.

 PARK CITY MUNICIPAL CORPORATION WATER	DATE	3" AND LARGER METER INSIDE SETTING	STD. PLAN
	05/2025		528
	REV.		
	2		

LEGEND AND APPROVED PARTS LIST

ITEM	DESCRIPTION	ACCEPTABLE MANUFACTURER	MODELS
①	DUCTILE IRON TEE, FLG., PRESSURE CLASS 350, CEMENT-MORTAR LINED, ASPHALTIC INTERIOR COATING, AWWA C150 / C151 / C104	U.S. PIPE PACIFIC STATES	
		U.S. PIPE PACIFIC STATES	
②	DUCTILE IRON PIPE SPOOL, FLG. X FLG., 3" TO 12" DIAMETER, FULL BODY, PRESSURE CLASS 350, CEMENT-MORTAR LINED, ASPHALTIC INTERIOR COATING, AWWA C150 / C151 / C104	U.S. PIPE PACIFIC STATES	
③	2" BRONZE SERVICE SADDLE, DOUBLE STRAP	MUELLER	BR2B SERIES, FIP THDS
		FORD	STYLE 202B, FIP THDS
④	2" BRONZE BALL VALVE WITH LOCKING HANDLE, F.I.P., THREADED, 300 PSI RATED, LEAD FREE	FORD	B11-777Q
⑤	GATE VALVE, PIPE SIZE, NRS WITH HANDWHEEL, FLANGED, 2" SQ. OPERATING NUT, AWWA C509	MUELLER	SERIES A-2360
		CLOW	MODEL 2639
⑥	METER, SUPPLIED AND INSTALLED BY PCMC	SENSUS	OMNI
⑦	DUCTILE IRON PIPE SPOOL (2), FLG X PE		
⑧	DISMANTLING JOINT, WITH RESTRAINING BOLTS	ROMAC	DJ400 OR APPV'D EQUAL
⑨	2" BRONZE UNION, F.I.P., THREADED, LEAD FREE		
⑩	2" COPPER PIPE, TYPE K, WITH COPPER 90° ELBOW, SOLDERED, OR BRASS NIPPLE BRONZE, F.I.P., WITH THREADED 90° ELBOW (NO GALVANIZED MATERIALS)		
⑪	PIPE SUPPORTS, 2 REQ'D ON MAIN SERVICE LINE AND 2 REQ'D ON BYPASS SERVICE		
⑫	MXU AND WIRING, SUPPLIED AND INSTALLED BY PCMC		
⑬	1/2" EMT CONDUIT FOR MXU WIRING, AS REQUIRED		
⑭	SWING CHECK BACKFLOW ASSEMBLY	VAL-MATIC	W/ BACKFLOW ACTUATOR



PARK CITY MUNICIPAL CORPORATION
WATER

DATE

5/2025

REV.

2

**3" AND LARGER METER
INSIDE SETTING**

STD. PLAN

528 S.1

DETAIL NOTES

1. USE OF AN INSIDE WATER METER REQUIRES PUBLIC UTILITIES ENGINEER APPROVAL. REFERENCE WATER STANDARD PLAN 520 FOR APPLICABLE CONDITIONS.
2. FIRE SPRINKLER RISER WITH POTABLE WATER SERVICE: A SITE SPECIFIC DESIGN IS REQUIRED. THE FIRE PROTECTION SPRINKLER SYSTEM AND POTABLE WATER SYSTEM DESIGN SHALL BE APPROVED BY THE FIRE MARSHAL AND THE PARK CITY BUILDING DEPARTMENT. THE POTABLE WATER SERVICE CONNECTION AND METER ASSEMBLY DESIGN SHALL BE APPROVED BY THE PARK CITY BUILDING DEPARTMENT AND THE PUBLIC UTILITIES ENGINEER. DESIGN AND CONSTRUCTION SHALL COMPLY WITH APPLICABLE BUILDING AND PLUMBING CODES.
3. BACKFLOW PREVENTION: PROVIDE A DOUBLE CHECK BACKFLOW ASSEMBLY (DC) ON THE FIRE SPRINKLER RISER ASSEMBLY. REDUCED PRESSURE PRINCIPLE BACKFLOW ASSEMBLY (RP) ALLOWED WITH PUBLIC UTILITIES ENGINEER APPROVAL. STYLE TO BE DETERMINED BY THE BUILDING AND WATER DEPARTMENT BASED ON DEGREE OF HAZARD POSED BY FIRE SPRINKLER PROTECTION SYSTEM. BEFORE A CERTIFICATE OF OCCUPANCY CAN BE ISSUED BY THE BUILDING DEPARTMENT, BACKFLOW ASSEMBLY TESTING FOR PROPER OPERATION (PER CITY REQUIREMENTS BY A CERTIFIED TESTER RECOGNIZED BY THE CITY) IS REQUIRED AND A REPORT SUBMITTED.
4. CONNECTIONS TO THE WATER SYSTEM ARE NOT PERMITTED PRIOR TO THE POTABLE WATER METER ASSEMBLY OR THE FIRE SPRINKLER RISER BACKFLOW ASSEMBLY. THIS INCLUDES OUTSIDE IRRIGATION SUPPLY.
5. CLEARANCES: PROVIDE ADEQUATE CLEARANCES FROM FIRE RISER AND AROUND WATER METER ASSEMBLY. MAINTAIN: 9" MINIMUM FROM WALL TO FACE OF POTABLE WATER PIPING
18" CLEAR ON EACH SIDE OF METER ASSEMBLY
36" CLEAR IN FRONT OF METER ASSEMBLY
6. LOCATE METER ASSEMBLY TWO (2) TO FOUR (4) FEET ABOVE THE FLOOR. POSITION METER HORIZONTAL WITH DIAL POINTING UP.
7. VERIFY METER LAY LENGTH WITH WATER DEPARTMENT PRIOR TO INSTALLING PIPING
8. PROVIDE ISOLATION VALVES AT METER INLET AND OUTLET
9. FOR MULTIPLE METERS PROVIDE A MANIFOLD WITH A MAIN VALVE PRIOR TO THE MANIFOLD AND INDIVIDUAL VALVES LOCATED PRIOR TO AND AFTER METERS.
10. PROVIDE A FLOOR DRAIN IN THE FIRE RISER ROOM WITHIN 10 FEET OF THE WATER METER LOCATION.
11. PROVIDE PIPE LABELS ON THE POTABLE WATER LINE BETWEEN THE FIRE RISER AND THE WATER METER DESIGNATING PIPE AS "POTABLE WATER".
12. PROVIDE PIPE ANCHORAGE TO SUPPORT METER ASSEMBLY INDEPENDENT OF THE POTABLE WATER SUPPLY PIPING AND BUILDING PLUMBING. PROVIDE PIPE STANDS OR UNISTRUT WALL STANDOFFS. DO NOT SUPPORT METER ASSEMBLY FROM OTHER PIPING.
13. PROVIDE A WALL PENETRATION AND CONDUIT FOR REMOTE RADIOREAD METER TRANSEIVER UNIT (MXU) DEVICE(S). COORDINATE ROUTING AND WALL PENETRATION LOCATION WITH THE WATER DEPARTMENT. REFERENCE WATER STANDARD PLANS 520 AND 530.
14. PROVIDE 1/2" EMT CONDUIT AND SUPPORTS FOR MXU SIGNAL WIRE IF DISTANCE TO WALL PENETRATION EXCEEDS 10 FEET.
15. INSPECTION: CONTACT THE CITY ENGINEER FOR INSPECTION OF THE POTABLE WATER SYSTEM METER ASSEMBLY INSTALLATION.
16. REFER TO STD. PLAN 500 AND THE SPECIFICATIONS FOR FLUSHING, HYDROSTATIC TESTING, AND DISINFECTING REQUIREMENTS
17. BUILDING OWNER IS RESPONSIBLE TO HAVE THE BACKFLOW PREVENTER FLOW TESTED AND INSPECTED INTERNALLY AT LEAST ONCE PER YEAR, OR MORE AS CONDITIONS WARRANT, IN ACCORDANCE WITH NFPA 13 AND NFPA 25 AND A REPORT SUBMITTED TO THE PARK CITY BUILDING DEPARTMENT

 PARK CITY MUNICIPAL CORPORATION WATER	DATE	3" AND LARGER METER INSIDE SETTING	STD. PLAN
	5/2025		528 S.2
	REV.		
	2		

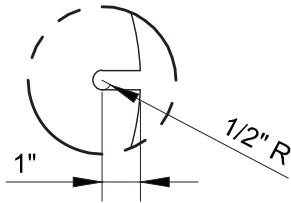

PLAN VIEW A

4 1/2" DIA. RECESS
W/ 2" TAP

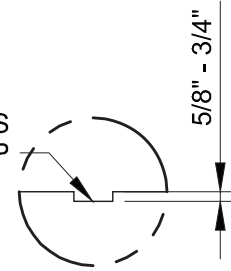

PLAN VIEW B

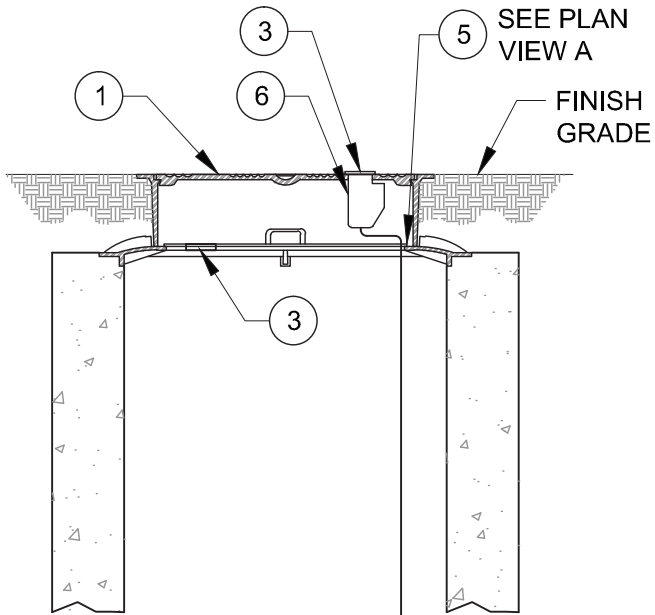

LANDSCAPE AREA

ALTERNATE LOCATION WITH
RECESSED HOLE IN LID

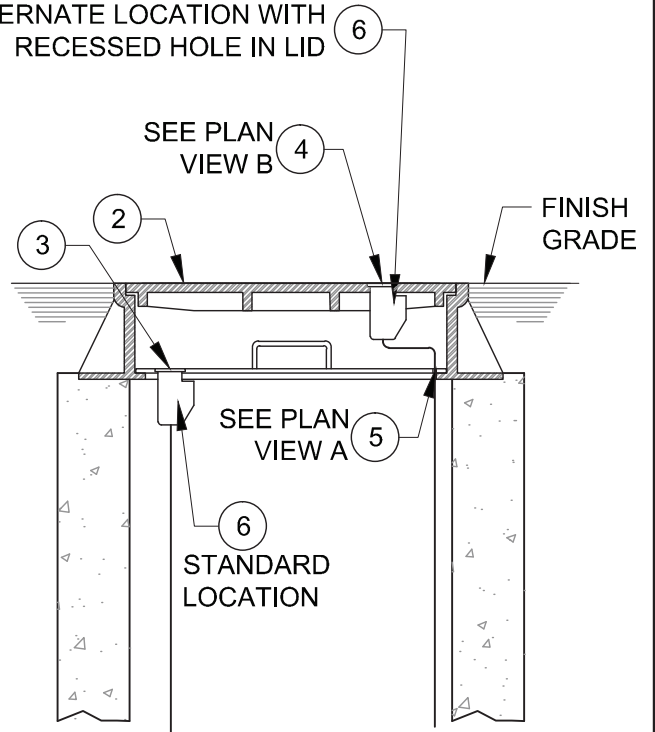

PAVEMENT AREA



PARK CITY MUNICIPAL CORPORATION
WATER

DATE

03/2014

REV.

0

**METER VAULT FRAME AND
COVER / MXU DEVICE
LOCATION**

STD. PLAN

529

LEGEND AND APPROVED PARTS LIST

ITEM	DESCRIPTION	ACCEPTABLE MANUFACTURER	MODELS
①	METER VAULT FRAME AND COVER, MARKED "WATER"	D&L SUPPLY	L-2320, OR APPROVED EQUAL
②	METER VAULT FRAME AND COVER, TRAFFIC RATED, MARKED "WATER"	D&L SUPPLY	A-1019, OR APPROVED EQUAL
③	2" TAP AND PLUG, REQUIRED	FORD OR APPROVED EQUAL	PLUG: PTP-3-25
④	2" TAP WITH RECESSED PLUG, REQUIRED (PLAN VIEW 'B')		
⑤	NOTCH INNER FROST FREE LID FOR SIGNAL WIRE (PLAN VIEW 'A')		
⑥	MXU AND WIRING, SUPPLIED AND INSTALLED BY PCMC		
⑦	METER VAULT, MATERIALS VARY		

DETAIL NOTES

1. REFER TO STD. PLAN 592 AND 593 FOR METER VAULT ADJUSTMENT AND GRADING REQUIREMENTS
2. PROVIDE TAPS FOR STANDARD AND ALTERNATE MXU LOCATIONS
3. PROVIDE PLUGS FOR ALL OPENINGS
4. REMOVE ALL BURRS FROM TAPS AND NOTCHES
5. REFER TO STD PLAN 530 FOR REMOTE MXU REQUIREMENTS

 PARK CITY MUNICIPAL CORPORATION WATER	DATE	METER VAULT FRAME AND COVER / MXU DEVICE LOCATION	STD. PLAN
	10/2020		529 S
	REV.		
	1		

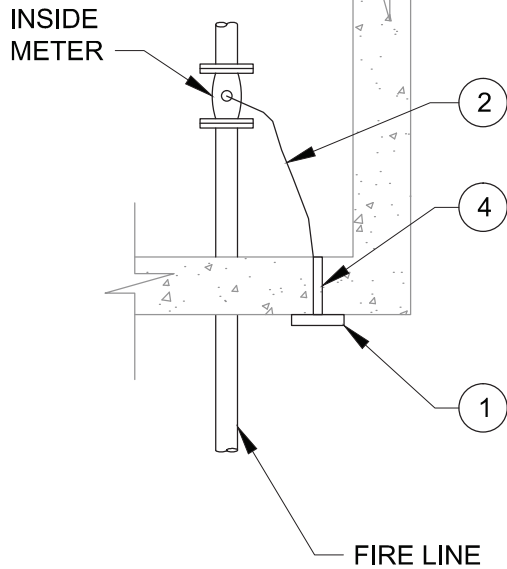

INSIDE METER

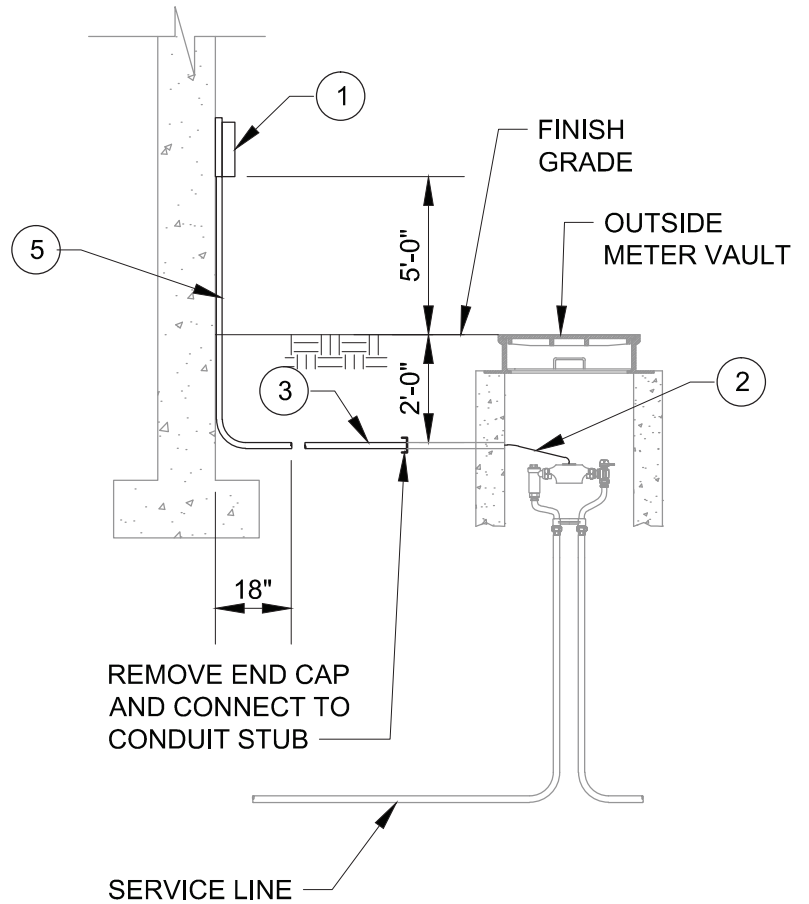

OUTSIDE METER

LEGEND	
ITEM	DESCRIPTION
①	REMOTE RADIO READ MXU, 6"X6", DEVICE SURFACE MOUNT, BY PCMC
②	MXU SIGNAL WIRE, SUPPLIED AND INSTALLED BY PCMC
③	3/4" PVC NEMA TC-2 CONDUIT BY CUSTOMER
④	WALL PENETRATION, BY CUSTOMER
⑤	3/4" GALVANIZED RIGID STEEL CONDUIT, BY CUSTOMER

NOTES:

- REFER TO STD. PLAN 520 FOR GENERAL REQUIREMENTS - METER, METER VAULT, AND SERVICE LINE.

 PARK CITY MUNICIPAL CORPORATION WATER	DATE	REMOTE MXU DEVICE	STD. PLAN
	03/2014		530
	REV.		
	0		

DETAIL NOTES:

1. USE OF A PCMC FIRE HYDRANT FOR OBTAINING CONSTRUCTION WATER REQUIRES A VALID CUSTOMER WATER SERVICE AGREEMENT. THE AGREEMENT CAN BE OBTAINED FROM THE PUBLIC WORKS DEPARTMENT. A DEPOSIT FEE IS REQUIRED.
2. CONTRACTOR (CUSTOMER) IS RESPONSIBLE TO PICK UP THE PCMC PROVIDED HYDRANT METER ASSEMBLY FROM THE PUBLIC WORKS DEPARTMENT. COORDINATE PICK UP 24 HOURS PRIOR TO ARRIVAL.
3. CONTRACTOR SHALL BE RESPONSIBLE TO INSTALL AND NOTIFY THE PARK CITY FIRE SERVICE DISTRICT OFFICE OF THE HYDRANT CONNECTION.
4. FULLY OPEN THE FIRE HYDRANT VALVE PRIOR TO OPERATION. DO NOT USE THE FIRE HYDRANT VALVE FOR THROTTLING, USE THE BACKFLOW ASSEMBLY VALVE. DO NOT CLOSE VALVES ON THE ASSEMBLY OR THE DISCHARGE LINE QUICKLY.
5. CONTRACTOR SHALL PROTECT THE HYDRANT METER ASSEMBLY FROM DAMAGE, THEFT, AND MISUSE.
6. CONTRACTOR IS RESPONSIBLE FOR ANY AND ALL WATER CONSUMPTION.
7. CONTRACTOR SHALL NOTIFY PCMC WATER DEPARTMENT AND REMOVE AND RETURN THE HYDRANT METER ASSEMBLY WHEN HYDRANT USE IS COMPLETE. RELOCATION OF THE HYDRANT METER ASSEMBLY REQUIRES PRIOR NOTIFICATION TO THE WATER DEPARTMENT AND A MODIFICATION TO THE CUSTOMER SERVICE AGREEMENT.
8. CONTRACTOR IS RESPONSIBLE FOR ANY AND ALL DAMAGE TO METER AND HYDRANT WHILE IN USE.

 PARK CITY MUNICIPAL CORPORATION WATER	DATE	TEMPORARY HYDRANT METER ASSEMBLY	STD. PLAN
	03/2023		531
	REV.		
	2		

PCMC WATER SYSTEM – CORROSION PROTECTION REQUIREMENTS:

PCMC HAS EXPERIENCED EXTERNAL CORROSION OF WATER DISTRIBUTION MATERIALS IN VARYING DEGREES THROUGHOUT THE CITY. TO MAXIMIZE THE LIFE CYCLE OF WATER SYSTEM IMPROVEMENTS, AS IMPACTED BY THE IMMEDIATE SITE CONDITIONS AND THE SELECTION OF MATERIALS, THE CITY HAS IDENTIFIED KEY DESIGN AND CONSTRUCTION REQUIREMENTS.

1. **FOR PROJECTS WITH LESS THAN 300 FEET OF NEW WATER PIPE** AND APPURTENANCES, CORROSION PROTECTION SHALL BE ADDRESSED IN THE FOLLOWING MANNER:
 - a. IN ADDITION TO THE REQUIRED POLYETHYLENE WRAP, APPLY A WAX TAPE COATING SYSTEM TO VALVE BONNET BOLTS, SADDLES, CORP STOPS, STAINLESS REPAIR CLAMPS AND ALL OTHER BURIED BOLTS, NUTS, CONNECTORS, RESTAINER GLAND BOLTS, AND COUPLING HARDWARE, AWWA C217. COATING SYSTEM TO INCLUDE A 4-MIL MINIMUM WAX TAPE PRIMER, FILLER MATERIAL, 45-MIL MINIMUM WAX TAPE AND PROTECTIVE OUTER WRAP. WHEN WAX TAPING A STAINLESS CLAMP THE ENTIRE CLAMP SHOULD BE WRAPPED NOT JUST BOLTS.
 - b. WAX TAPE COATING MATERIALS:
 - i. DENSO NORTH AMERICA DENSO PRIMER, DENSYL TAPE AND/OR MASTIC, DENSO FIBER-WRAP
 - ii. TRENTON PRIMER, #1 WAX-TAPE, AND GUARD-WRAP
 - iii. OR APPROVED EQUAL (SUBMITTAL TO CITY AND WRITTEN APPROVAL REQUIRED PRIOR TO INSTALLATION)

2. **FOR PROJECTS EXCEEDING 300 FEET OF NEW WATER PIPE** AND APPURTENANCES, CORROSION PROTECTION SHALL BE ADDRESSED IN THE FOLLOWING MANNER:
 - a. THE DEVELOPER AND ITS' DESIGN ENGINEER, GEOTECHNICAL ENGINEER, AND CORROSION CONSULTANT SHALL PROVIDE A SITE SPECIFIC "CORROSION STUDY REPORT". THE REPORT SHALL INCORPORATE PROJECT SPECIFIC FINDINGS INTO CORROSION PROTECTION RECOMMENDATIONS FOR THE PROPOSED WATER SYSTEM IMPROVEMENTS. THE REPORT SHALL INCLUDE AT A MINIMUM THE FOLLOWING ITEMS:
 - i. DETAILED INFORMATION ON EXISTING CONDITIONS, SOIL TYPES, CLASSIFICATION, ETC.
 - ii. IDENTIFICATION OF STRAY CURRENT SOURCES AND ANY EXISTING CORROSION PROTECTION SYSTEMS IN THE IMMEDIATE AREA
 - iii. IDENTIFICATION OF ANY POTENTIAL FOR HOT SPOTS OR VARYING SOIL CONDITIONS THAT MAY WARRANT CHANGES TO THE CORROSION PROTECTION PLAN DURING CONSTRUCTION.
 - iv. FIELD SAMPLING AND TESTING RESULTS WITHIN THE PROPOSED PIPE ZONE BASED ON REPRESENTATIVE SAMPLING OF THE DEVELOPMENT AREA CONDITIONS
 - v. SOIL RESISTIVITY TESTING RESULTS IDENTIFYING CORROSIVE SOIL CONDITIONS AND LOCATIONS (WENNER 4-PIN SOIL RESISTIVITY TESTS AND SOIL BOX RESISTIVITY TESTS) AT REPRESENTATIVE PIPE INSTALL DEPTHS
 - vi. LABORATORY ANALYSIS OF SOIL SAMPLES FOR PH, CHLORIDES, SULFATES, TOTAL SALTS, AND CONDUCTIVITY
 - vii. DETERMINATION OF THE NEED FOR CORROSION PROTECTION BASED ON SOIL CORROSIVITY CLASSIFICATION/SOIL RESISTIVITY AND RECOMMENDATION OF SUITABLE PIPE, CONSTRUCTION MATERIALS, PIPE PROTECTION METHOD, PIPE EXTERIOR COATINGS, ETC., BASED ON SITE CORROSIVITY. SEE TABLE BELOW.
 - viii. SPECIFY IF THE INVESTIGATION INCLUDES ONLY THE INITIAL PHASE OR ALL FUTURE PHASES

 PARK CITY MUNICIPAL CORPORATION WATER	DATE	METALLIC PIPE CORROSION PROTECTION	STD. PLAN
	10/2020		534.1
	REV.		
	1		

- b. FOLLOWING PCMC'S RECEIPT AND REVIEW OF THE CORROSION STUDY REPORT, THE DEVELOPER WILL BE NOTIFIED OF THE CITY'S DETERMINATION AS TO REQUIRED PROTECTION OR THE DESIGN TEAM WILL BE REQUESTED TO MEET AND REVIEW THE FINDINGS AND ESTABLISH THE FINAL WATER SYSTEM DESIGN CRITERIA. THE CITY'S REVIEW WILL BE BASED ON THE FOLLOWING TABLE 1:

TABLE 1 - SOIL CORROSIVITY CLASSIFICATION VERSUS SOIL RESISTIVITY

CORROSIVITY	RESISTIVITY, OHM-CM	TREATMENT
EXTREMELY CORROSIVE	LESS THAN 1,000	SITE SPECIFIC DESIGN REQUIRED
VERY CORROSIVE	1,000 TO 3,000	SITE SPECIFIC DESIGN REQUIRED
CORROSIVE	3,000 TO 6,000	NON-METALLIC PIPE – WAX TAPE COATING SYSTEM ON BOLTS & NUTS, ANODE PROTECTED FITTINGS AND VALVES
MODERATELY CORROSIVE	6,000 TO 10,000	NON-METALLIC PIPE - WAX TAPE COATING SYSTEM ON BOLTS AND NUTS ON PIPE, FITTINGS, AND VALVES
MILDLY CORROSIVE	MORE THAN 10,000	WAX TAPE COATING SYSTEM ON BOLTS AND NUTS ON PIPE, FITTINGS, AND VALVES *ALWAYS REQUIRED UNLESS SOILS TESTING IS PROVIDED

- c. REFER TO PERTINENT PCMC WATER STANDARD PLANS OR PROVIDE CONSTRUCTION DRAWING DETAILS ASSOCIATED WITH CORROSION STUDY RECOMMENDATIONS AND THE PCMC FINAL APPROVED WATER SYSTEM

WAX TAPE INSTALLATION PROCEDURES

WIRE BRUSH AND SCRAPE THE SURFACE CLEAN OF DIRT, LOOSE COATING AND LOOSE RUST. APPLY A THIN FILM OF WAX-TAPE® PRIMER. IF THE SURFACE IS WET, COLD OR RUSTY, RUB AND PRESS ON PRIMER TO DISPLACE MOISTURE AND ENSURE ADHESION. THEN WRAP WAX-TAPE WRAP USING A 1" OVERLAP. ON STRAIGHT PIPE APPLY SLIGHT TENSION TO ENSURE CONTACT WITH SURFACE. ON IRREGULAR SURFACES ALLOW SLACK SO THE WRAP CAN BE MOLDED INTO CONFORMITY. IN EITHER CASE, PRESS AND FORM THE WRAP SO THERE ARE NO AIR POCKETS OR VOIDS UNDER THE WRAP. ALSO, PRESS AND SMOOTH OUT THE LAP SEAMS TO ENSURE THEY ARE SEALED AND APPLY OUTERWRAP. THE WRAP DOES NOT REQUIRE CURING OR DRYING TIME SO IT CAN BE BACKFILLED IMMEDIATELY.

 PARK CITY MUNICIPAL CORPORATION WATER	DATE	METALLIC PIPE CORROSION PROTECTION	STD. PLAN
	10/2020		534.2
	REV.		
	1		

TERMINAL BOARD WIRING DIAGRAM

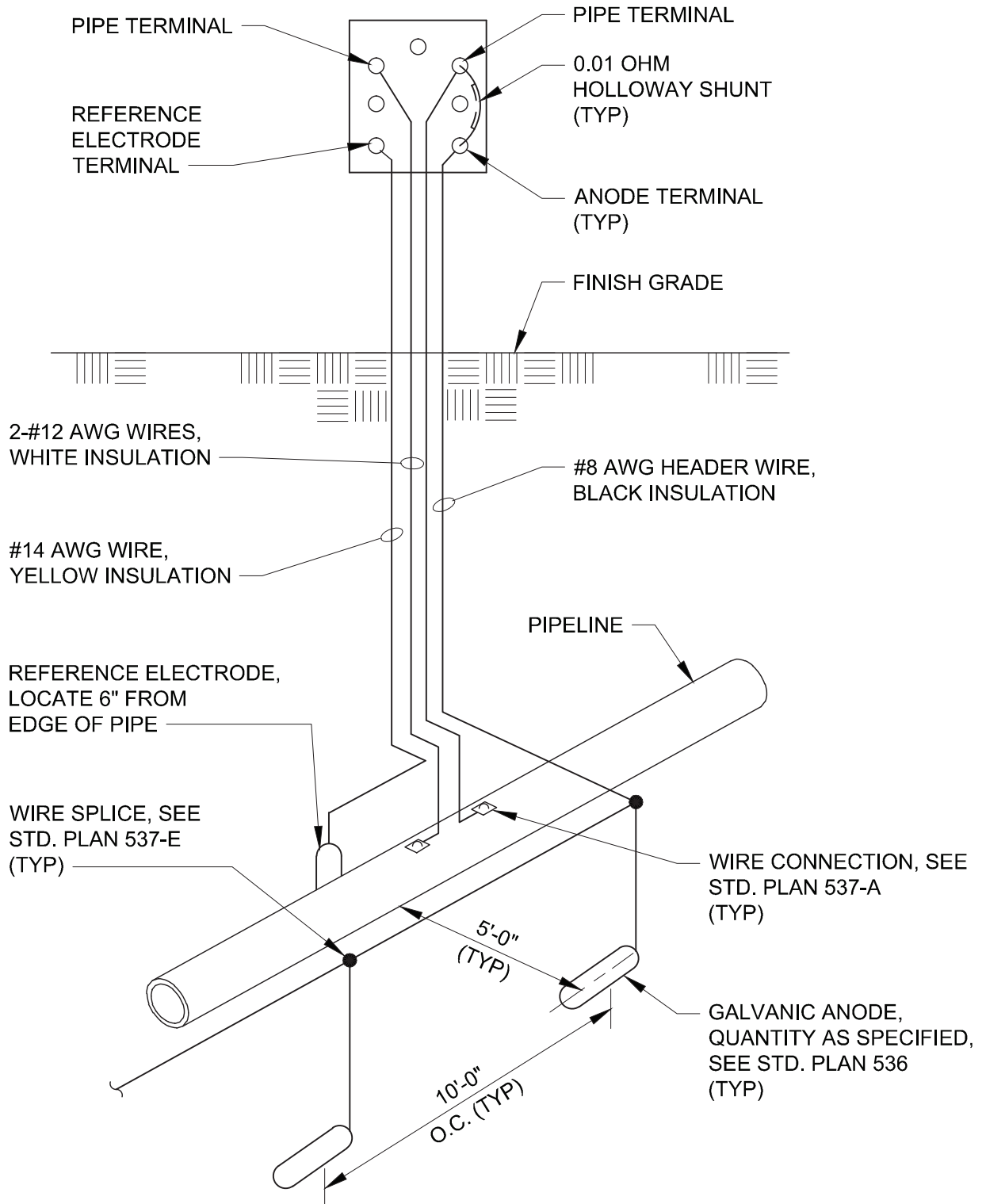



PARK CITY
1884
PARK CITY MUNICIPAL CORPORATION
WATER

DATE	12/2013
REV.	0

TYPE A TEST STATION

STD. PLAN	535-A
-----------	--------------

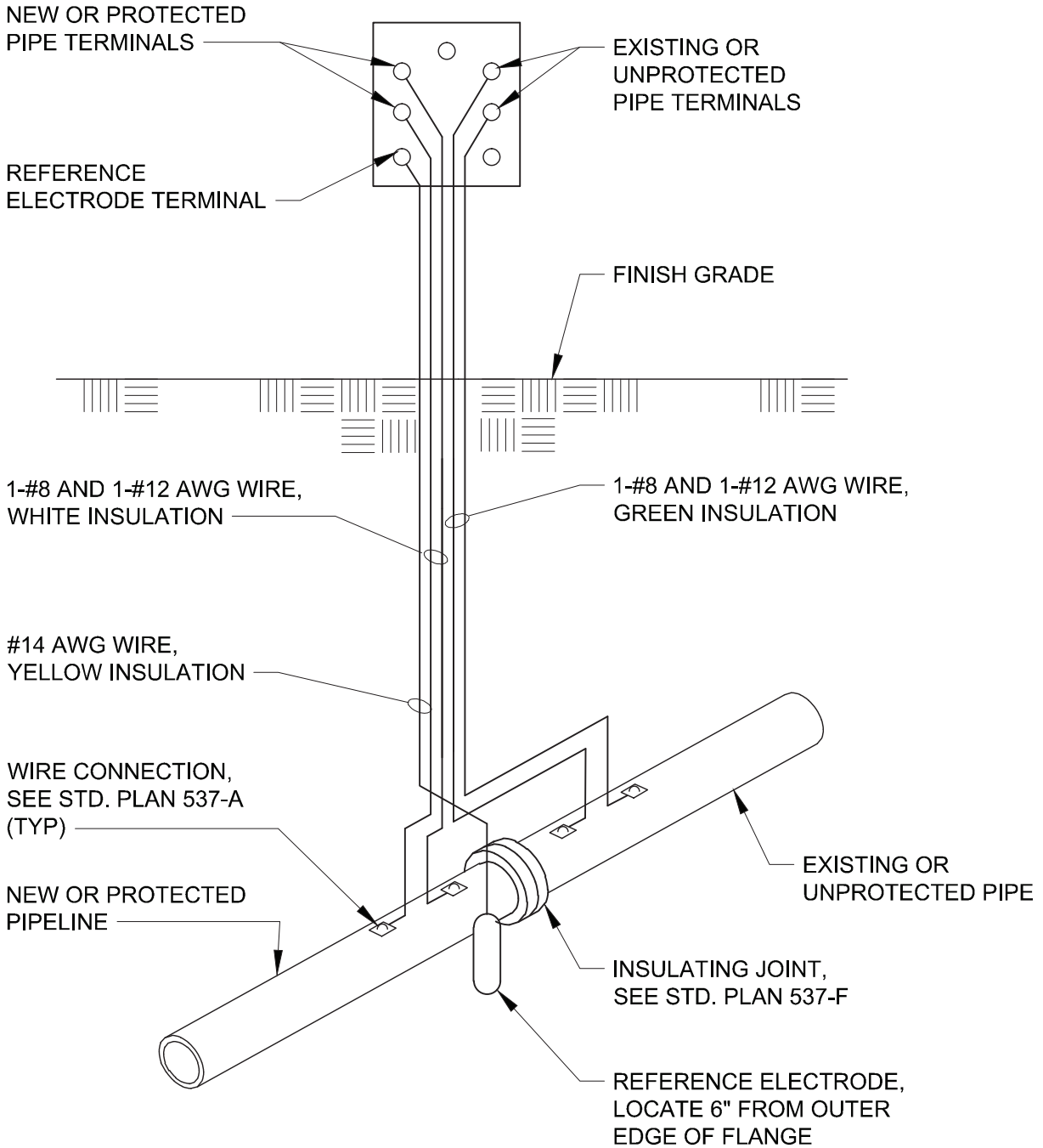
TERMINAL BOARD WIRING DIAGRAM



NOTE:
SEE POST OR FLUSH MOUNTED TEST STATION DETAILS AS APPLICABLE FOR TEST STATION STYLE REQUIRED.

 PARK CITY MUNICIPAL CORPORATION WATER	DATE	TYPE I TEST STATION	STD. PLAN
	12/2013		535-B
	REV.		
	0		

TERMINAL BOARD WIRING DIAGRAM

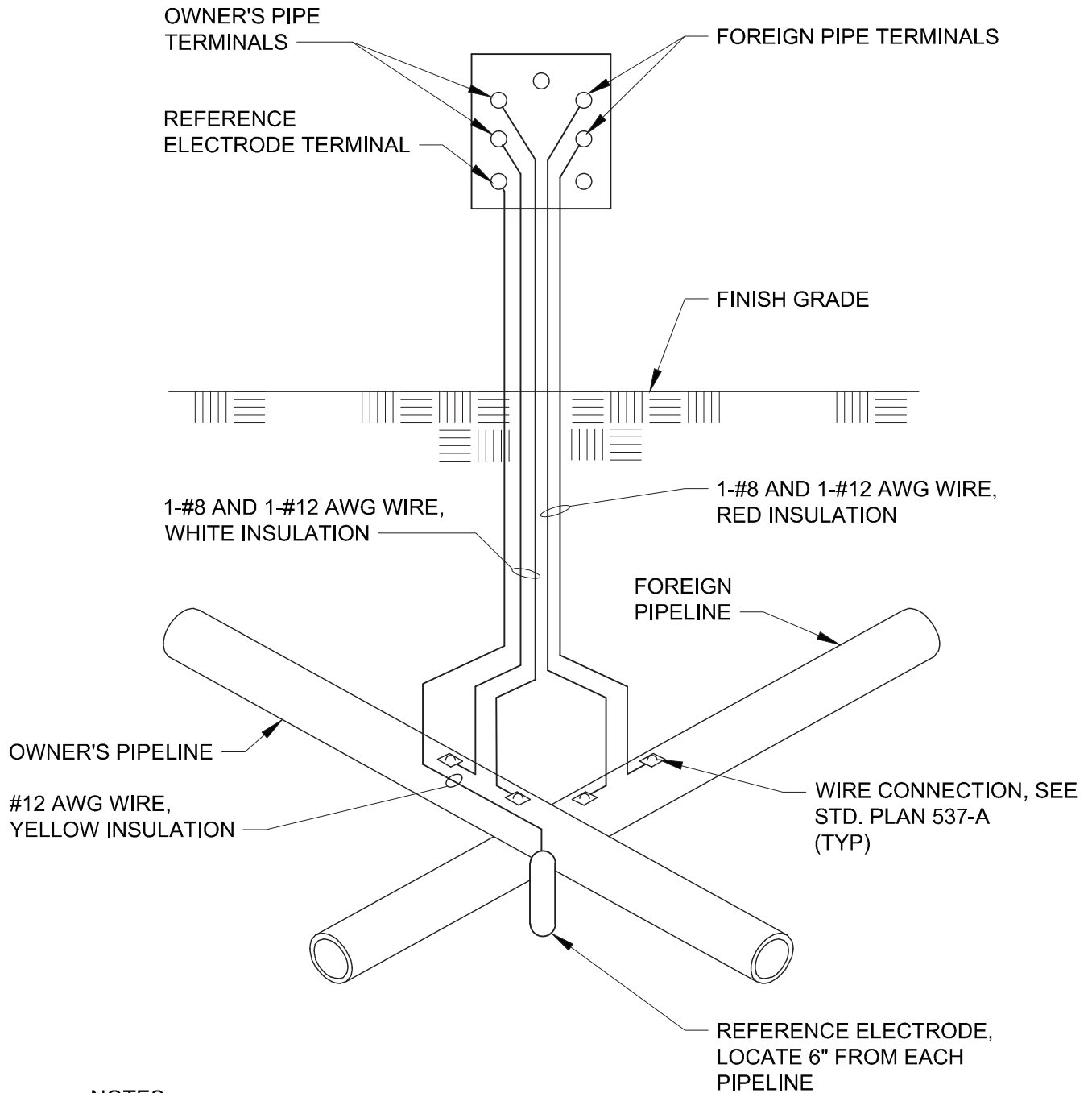

NOTES:

1. PRIOR TO MAKING WIRE CONNECTIONS CONTACT FOREIGN PIPELINE OWNER FOR APPROVAL.
2. SEE POST OR FLUSH MOUNTED TEST STATION DETAILS AS APPLICABLE FOR TEST STATION STYLE REQUIRED.

 PARK CITY MUNICIPAL CORPORATION WATER	DATE	TYPE F TEST STATION	STD. PLAN
	12/2013		535-C
	REV.		
	0		

TERMINAL BOARD WIRING DIAGRAM

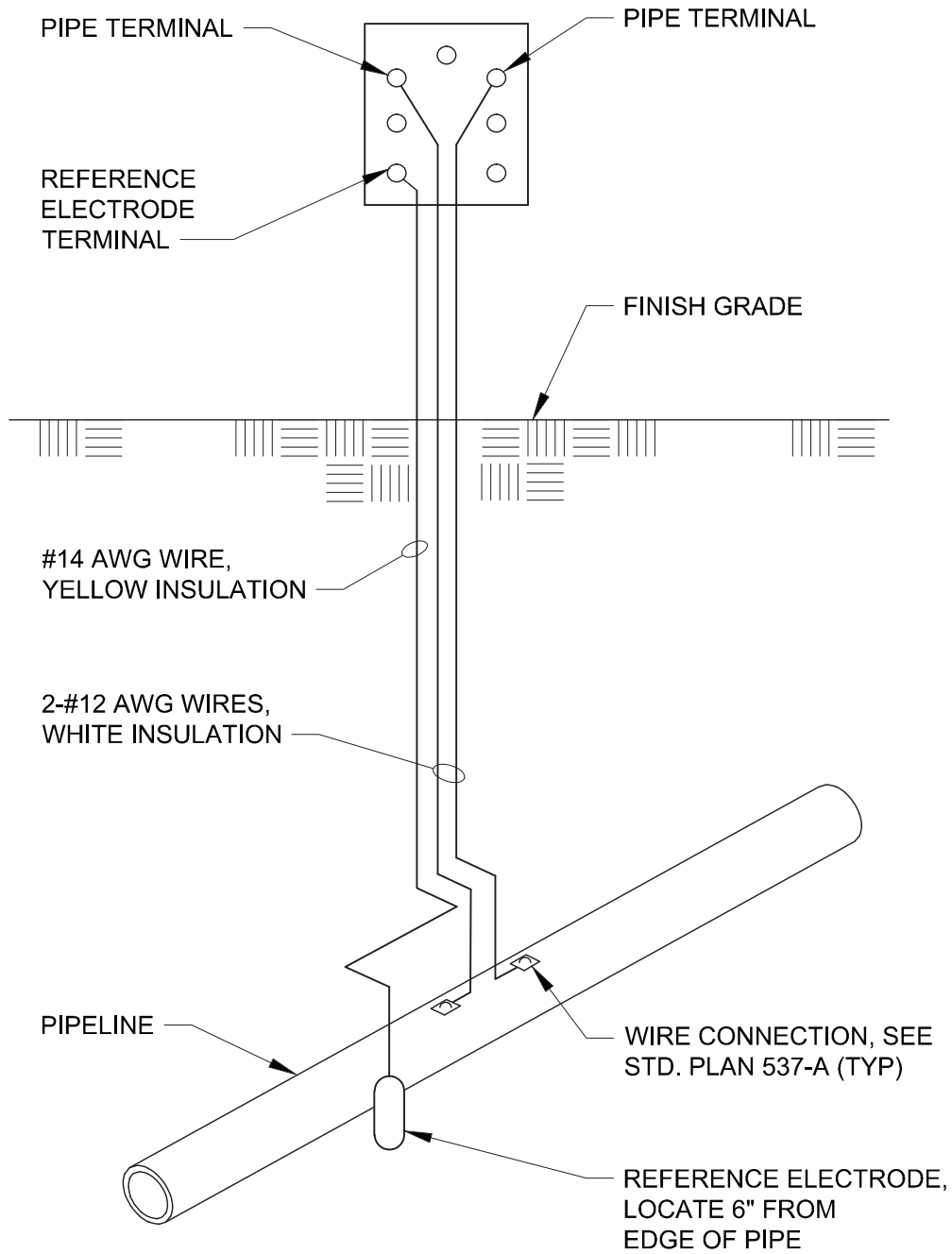

NOTE:
SEE POST OR FLUSH MOUNTED TEST STATION DETAILS AS APPLICABLE FOR TEST STATION STYLE REQUIRED.

 PARK CITY MUNICIPAL CORPORATION WATER	DATE	TYPE T TEST STATION	STD. PLAN
	12/2013		535-D
	REV.		
	0		

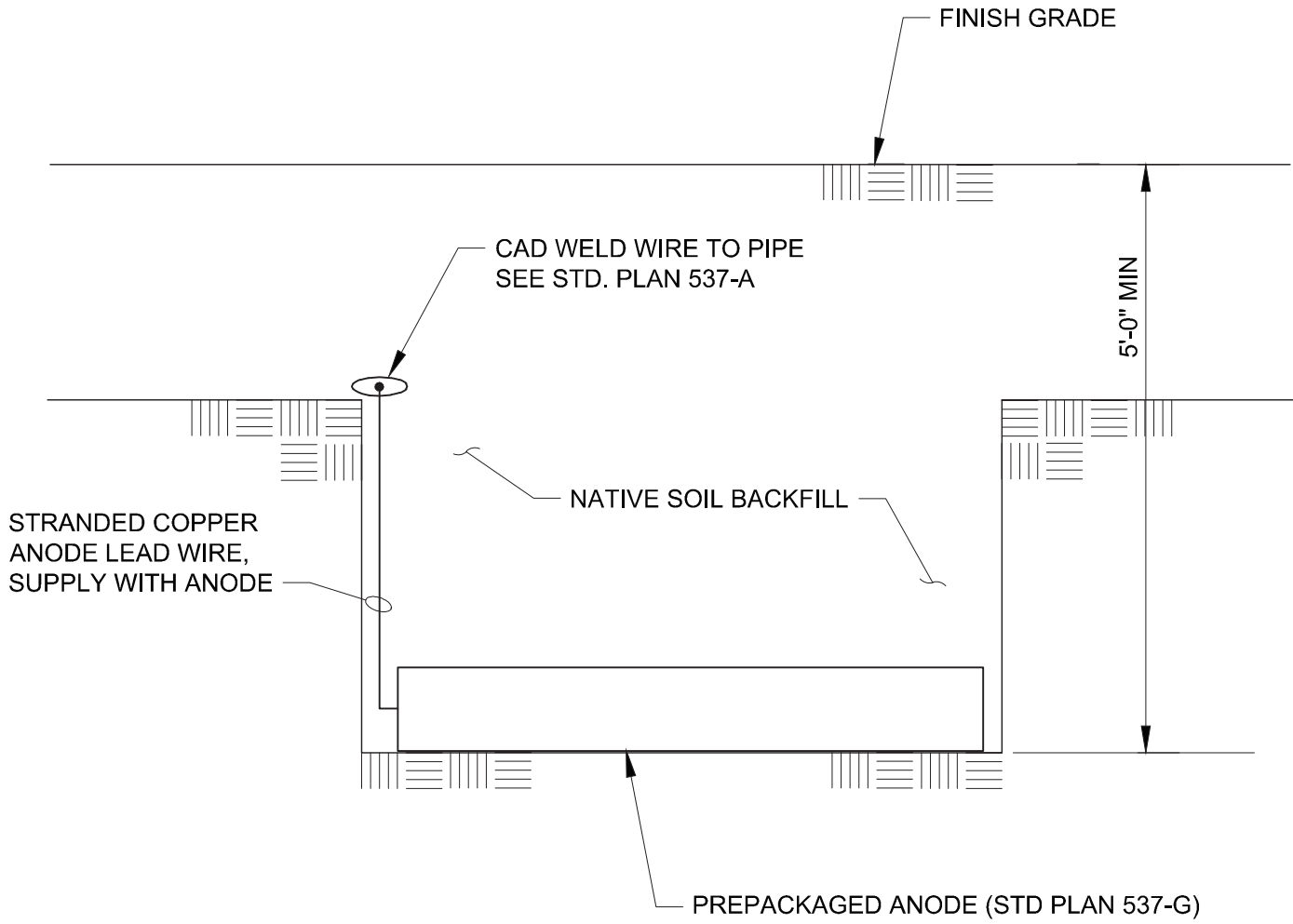

PARK CITY MUNICIPAL CORPORATION
WATER

DATE

04/2014

REV.

0

**HORIZONTAL GALVANIC
 ANODE INSTALLATION
 WITHOUT TEST STATION**

STD. PLAN

536-A

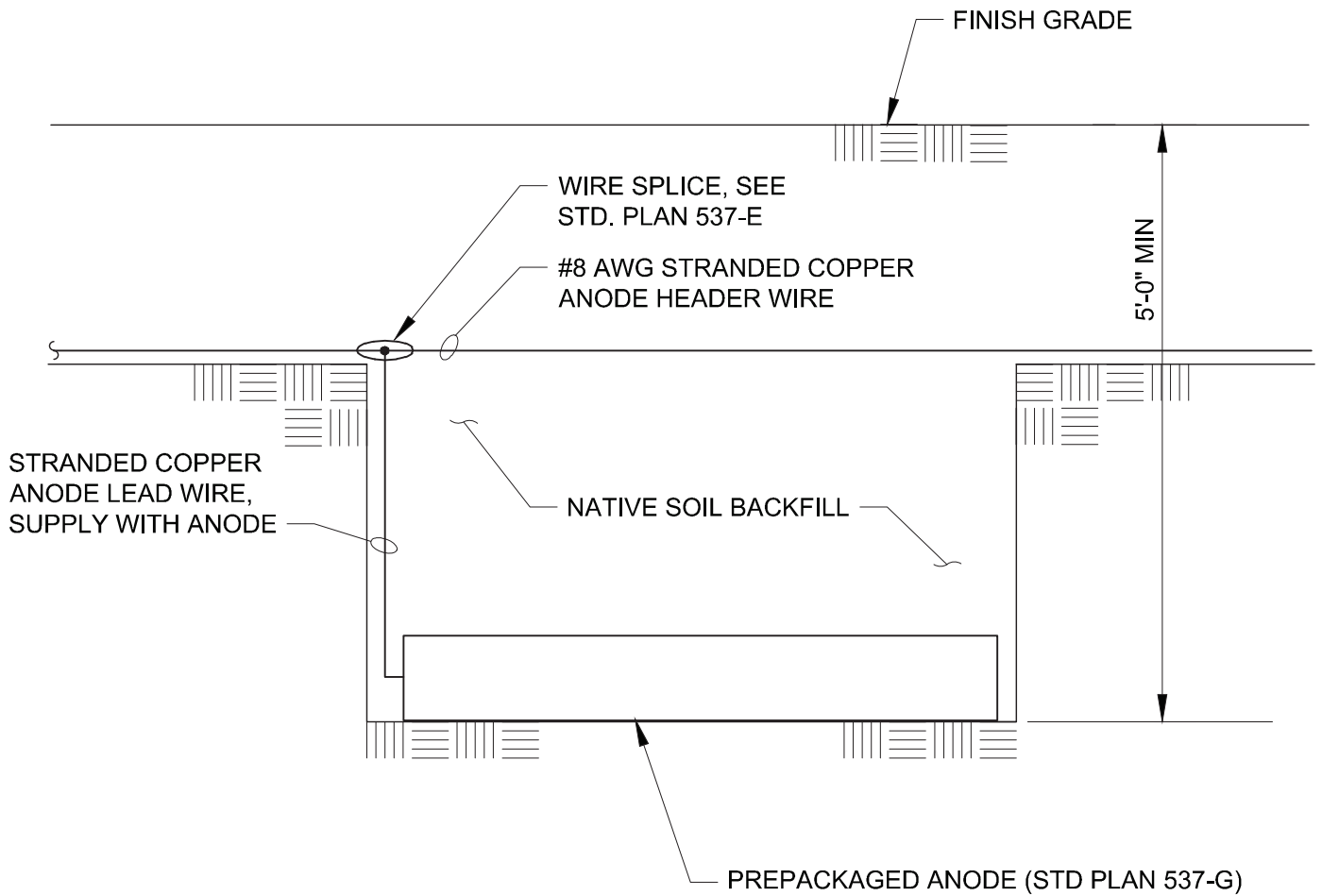

PARK CITY MUNICIPAL CORPORATION
WATER

DATE

03/2014

REV.

0

HORIZONTAL GALVANIC ANODE INSTALLATION

STD. PLAN

536-B

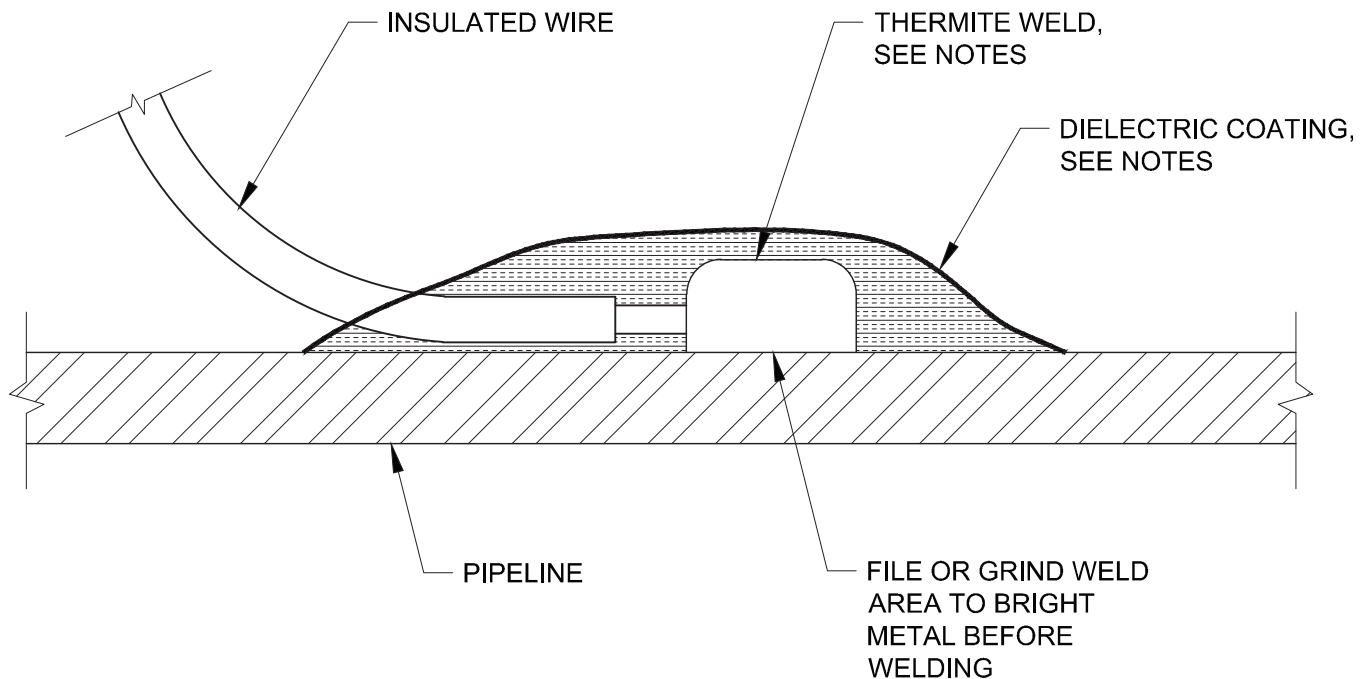

NOTES:

1. MAKE WIRE CONNECTION TO PIPE AT FIELD JOINT WHERE HOLDBACK OCCURS ON PIPELINE COATING.
2. MAINTAIN SEPARATION BETWEEN MULTIPLE TEST WIRE CONNECTIONS OF ONE PIPE DIA OR 24", WHICHEVER IS LESS.
3. COPPER SLEEVE REQUIRED FOR #2 AWG JOINT BONDS OR FOR #12 AWG OR SMALLER TEST WIRES.
4. WELDER AND CARTRIDGE SIZE VARIES ACCORDING TO PIPE SIZE AND PIPE MATERIAL, CONSULT WELDER MANUFACTURER FOR RECOMMENDED WELDER AND CARTRIDGE.
5. COAT COMPLETED CONNECTIONS, SEE STD PLAN 537-G.
6. PIPELINE JOINT COATING NOT SHOWN FOR CLARITY.



PARK CITY MUNICIPAL CORPORATION
WATER

DATE

04/2014

REV.

0

**STEEL AND DUCTILE IRON PIPE
WIRE CONNECTION**

STD. PLAN

537-A

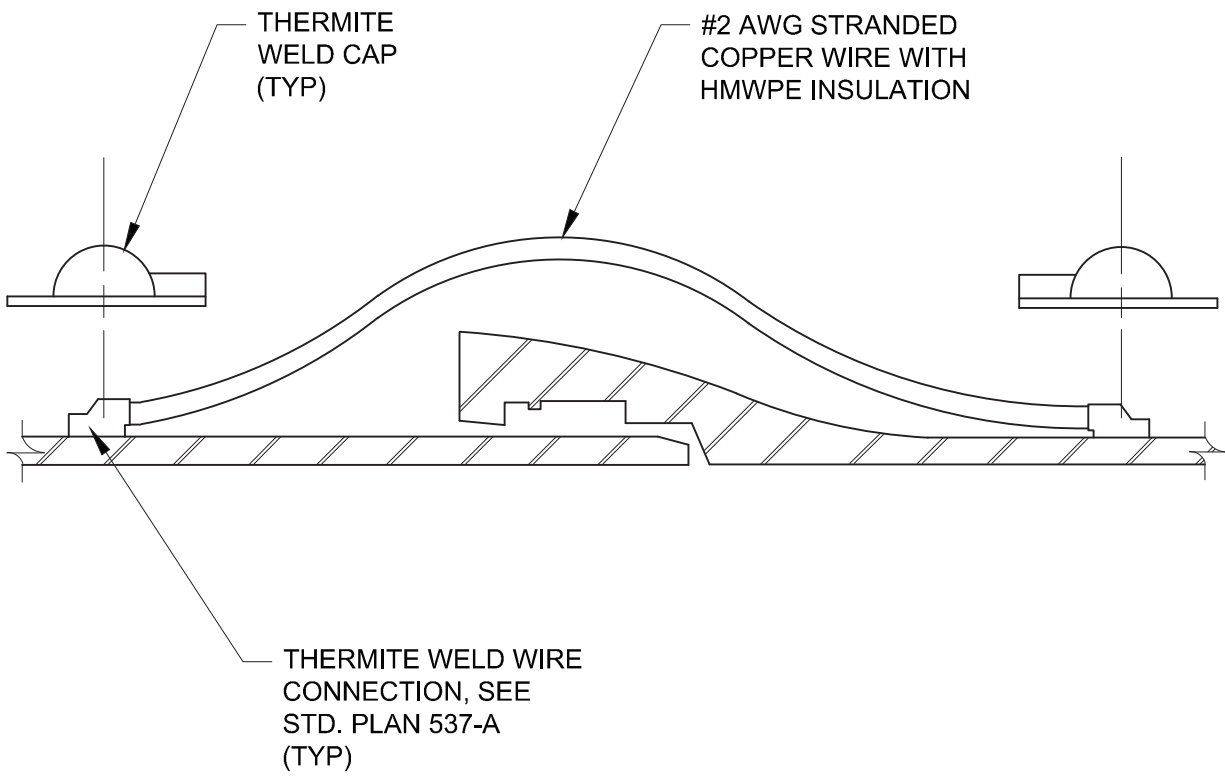

NOTES:

1. PUSH ON DUCTILE IRON BOND SHOWN, SIMILAR FOR DUCTILE MECHANICAL AND RESTRAINED JOINTS, AND STEEL CARNEGIE JOINTS.
2. INSTALL 2 BOND WIRES AT EACH PIPE JOINT, UNLESS SPECIFIED OTHERWISE.
3. COAT THERMITE WELDS WITH THERMITE WELD CAP OR FAST CURE EPOXY AT CONTRACTOR'S OPTION.

 PARK CITY MUNICIPAL CORPORATION WATER	DATE	DUCTILE IRON PIPE JOINT BOND	STD. PLAN
	12/2013		537-B
	REV.		
	0		

#2 AWG STRANDED
WIRE, HMWPE
INSULATION

#12 AWG STRANDED
WIRE PIGTAIL, THHN
INSULATION (TYP OF 2)

THERMITE WELD, SEE
STD. PLAN 537-A
(TYP)

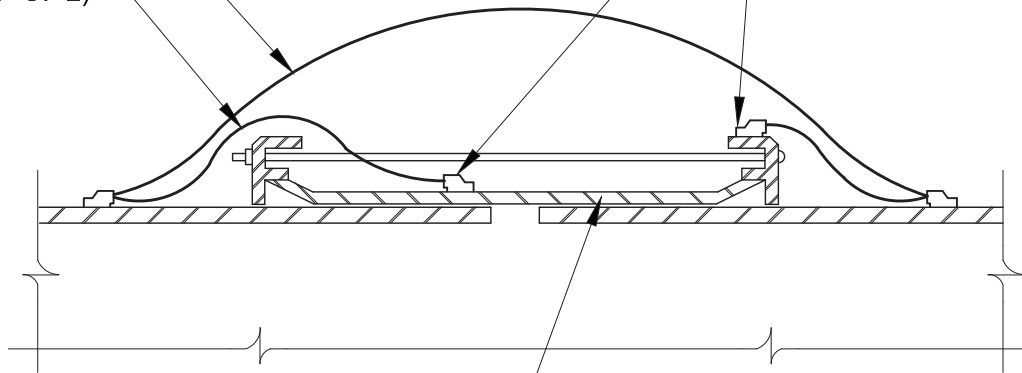

FLEXIBLE,
EXPANSION, OR
DEPEND-O-LOCK
TYPE COUPLING



PARK CITY MUNICIPAL CORPORATION
WATER

DATE

12/2013

REV.

0

FLEXIBLE JOINT BOND

STD. PLAN

537-C

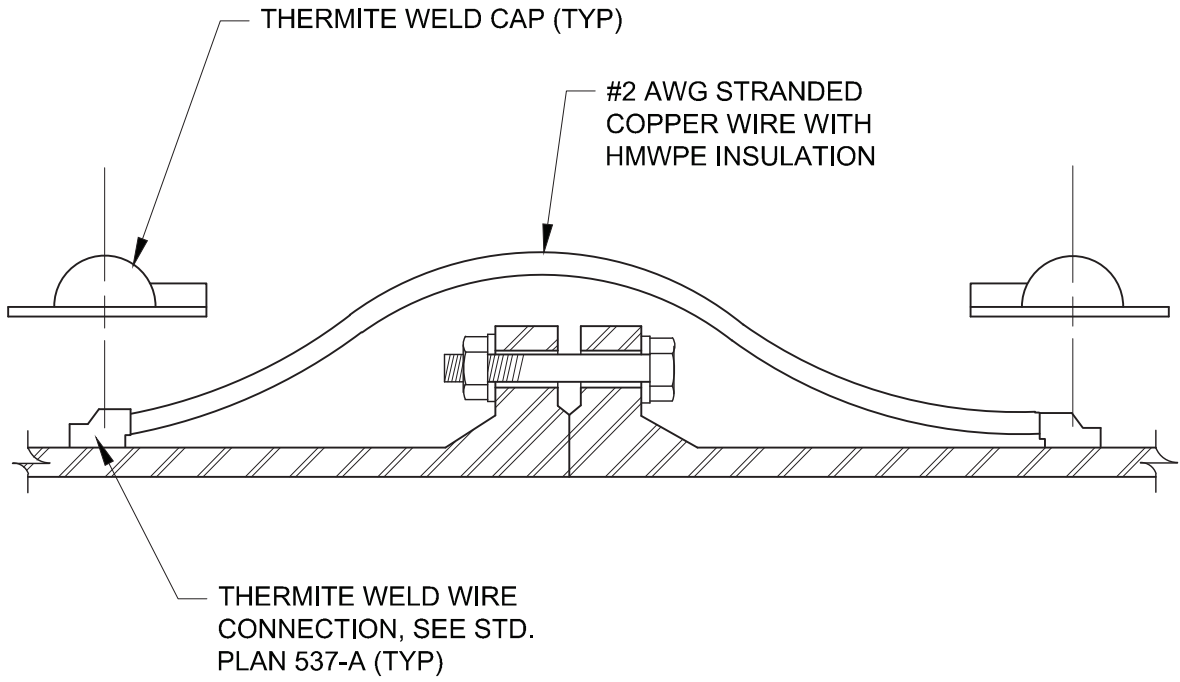

NOTE:
INSTALL TWO BOND WIRES AT EACH PIPE JOINT.



PARK CITY MUNICIPAL CORPORATION
WATER

DATE

12/2013

REV.

0

**FLANGED AND MECHANICAL
JOINT BOND**

STD. PLAN

537-D

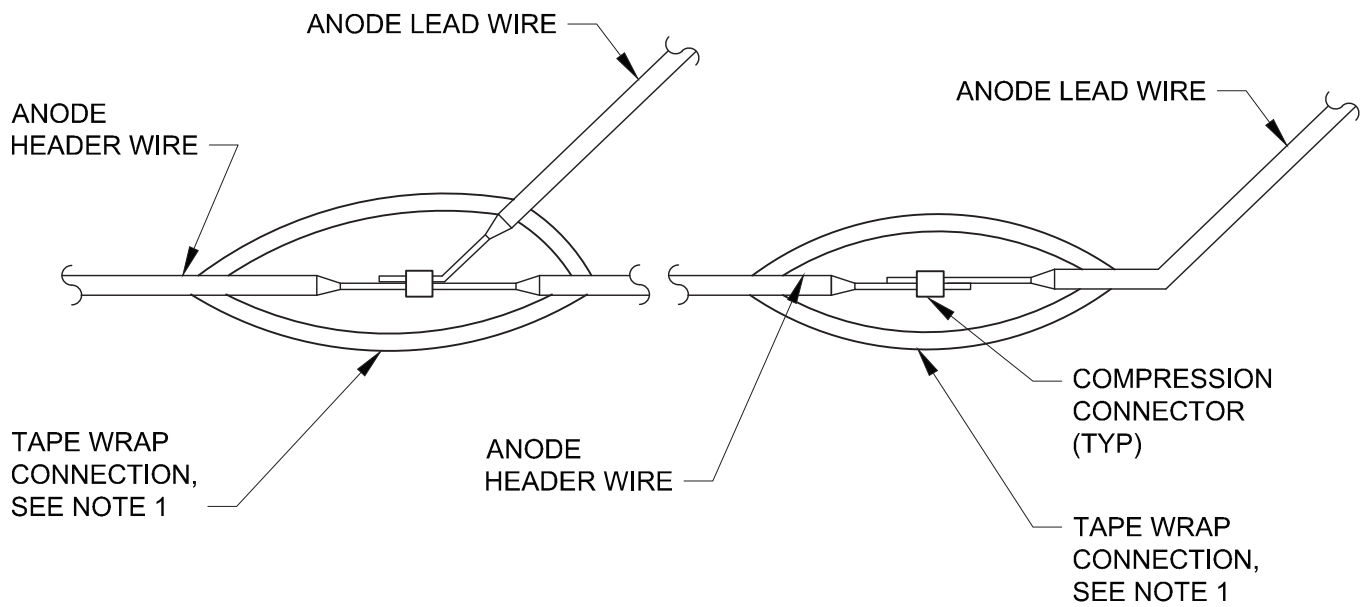

NOTES:

1. FILL VOIDS AND IRREGULARITIES WITH INSULATING PUTTY, WRAP CONNECTION WITH TWO LAYERS OF SCOTCH 130C SELF VULCANIZING RUBBER TAPE AND TWO LAYERS OF SCOTCH 88 VINYL ELECTRICAL TAPE.
2. DETAIL SIMILAR FOR ANODE HEADER WIRE SPLICES, SIZE COMPRESSION CONNECTORS AS REQUIRED.



PARK CITY MUNICIPAL CORPORATION
WATER

DATE

12/2013

REV.

0

**GALVANIC ANODE
WIRE SPLICE**

STD. PLAN

537-E

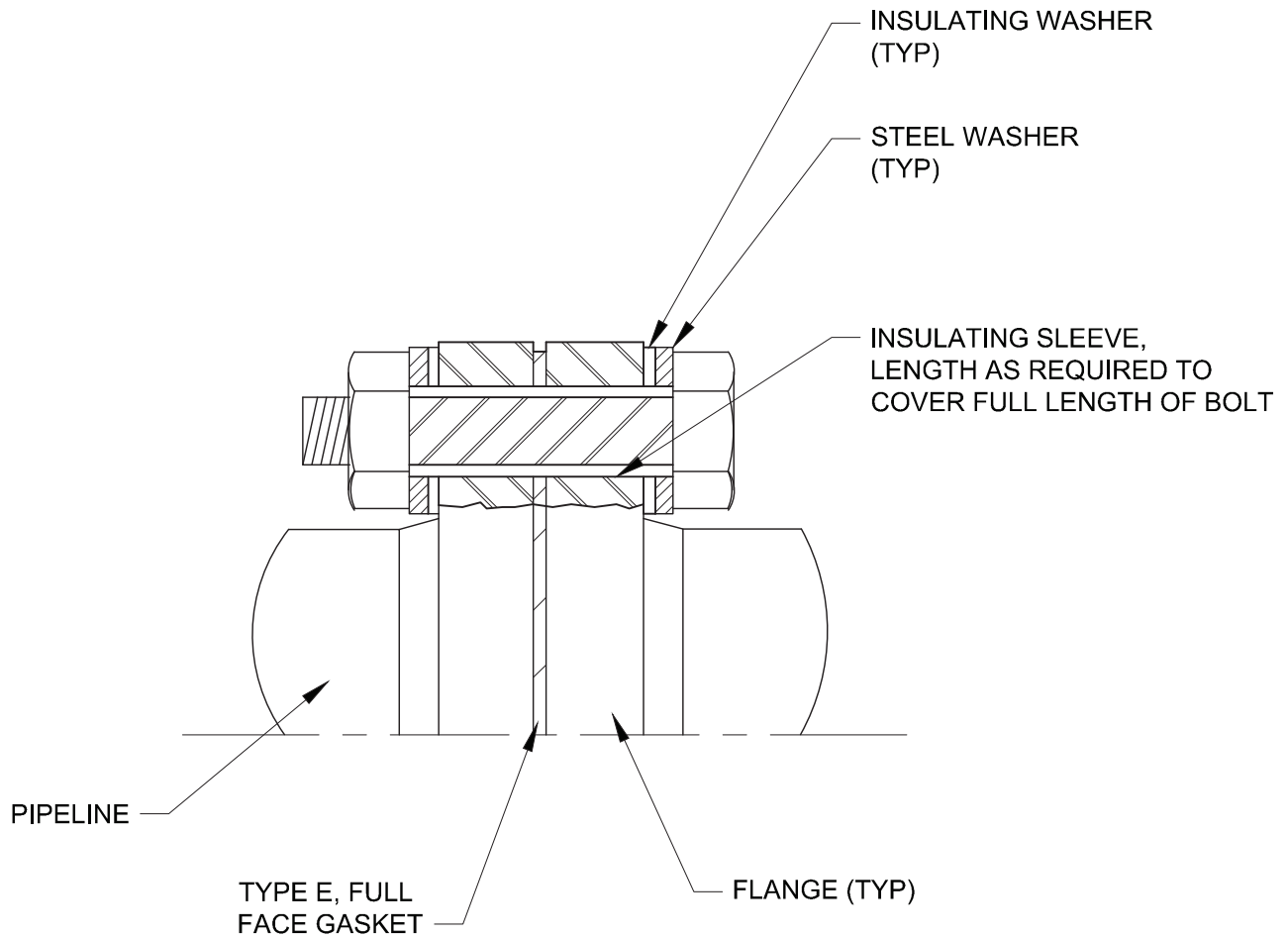

NOTES:

1. DOUBLE INSULATING WASHERS SHOWN FOR NON-BURIED INSULATING FLANGE INSTALLATIONS.
2. FOR BURIED OR SUBMERGED INSULATING FLANGE INSTALLATION USE SINGLE INSULATING WASHER ON UNPROTECTED SIDE OF INSULATING FLANGE.
3. COAT INTERIOR OF MORTAR LINED PIPE FOR TWO PIPE DIAMETERS WITH NSF APPROVED EPOXY AT 20 MILS DFT.
4. COAT BURIED OR IMMERSSED INSULATING FLANGES WITH SPECIFIED PIPELINE DIELECTRIC JOINT COATING OR HEAT SHRINK SLEEVE WITH MORTAR OVERCOAT ON MLC STEEL PIPE.
5. TEST COMPLETED JOINT FOR ELECTRICAL ISOLATION AND REPAIR AS REQUIRED.

 PARK CITY MUNICIPAL CORPORATION WATER	DATE	<h2>INSULATING FLANGE</h2>	STD. PLAN
	12/2013		<h1>537-F</h1>
	REV.		
	0		

SINGLE UNRESTRAINED
FITTING OR JOINT
RESTRAINT ASSEMBLY

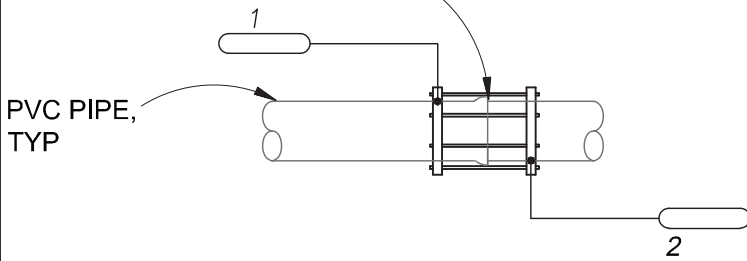

DETAIL A

LEGEND

- THERMITE WELD
- ANODE-SEE NOTES 2 THROUGH 8
- ⌒ #2 AWG BOND WIRE
- ⌒ #8 AWG BOND WIRE

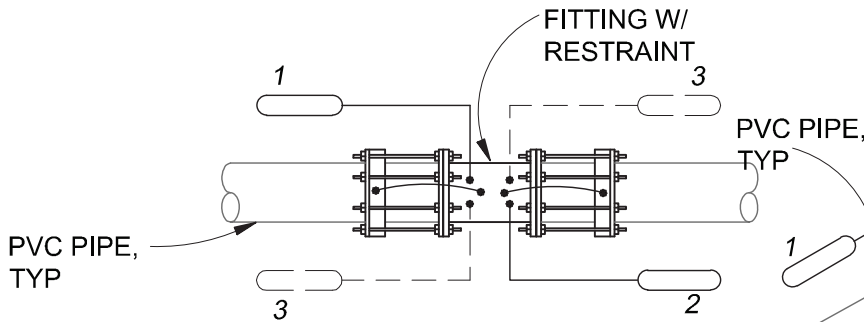

DETAIL B

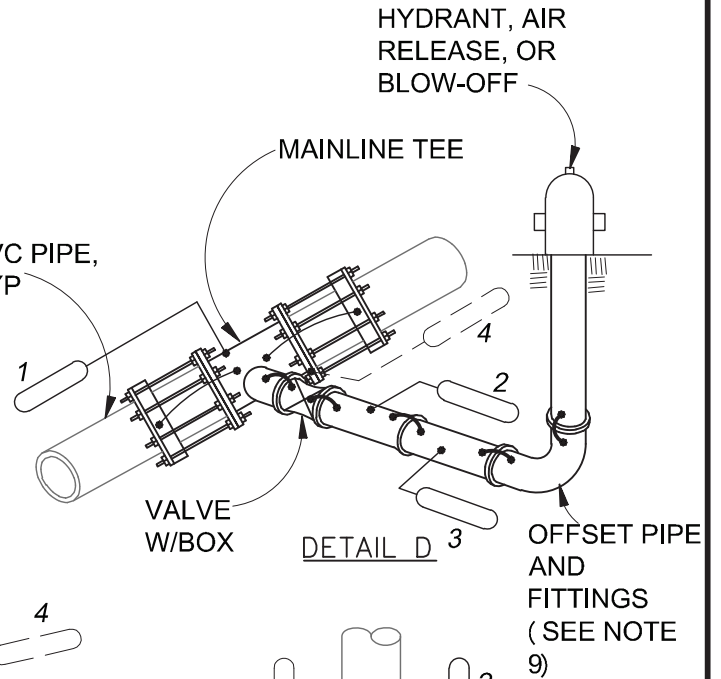

DETAIL D

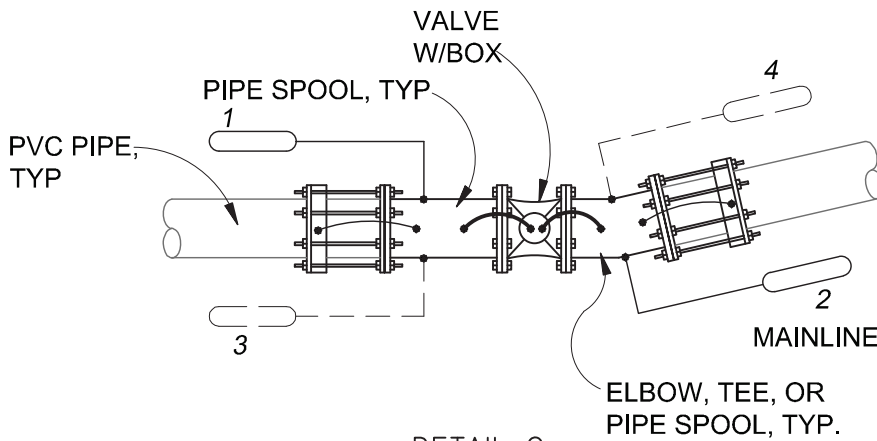

DETAIL C

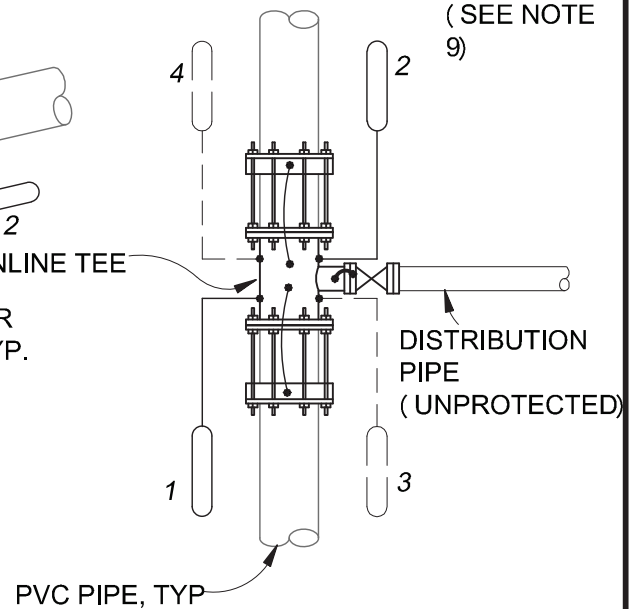

DETAIL E



PARK CITY MUNICIPAL CORPORATION
WATER

DATE

4/2014

REV.

0

**METALLIC PIPE
APPURTENANCE AND
FITTING CATHODIC
PROTECTION**

STD. PLAN

537-G.1

NOTES:

1. APPLY DIELECTRIC COATING TO ALL METALLIC FITTINGS, VALVES, PIPE, AND VALVE BOXES UNLESS SPECIFIED OTHERWISE.
2. GALVANIC ANODES SHALL BE H1 ALLOY MAGNESIUM ANODES AT THE BARE WEIGHT LISTED IN THE SCHEDULE, SUPPLY PREPACKAGED IN A CLOTH BAG AT 2.5 TIMES BARE WEIGHT IN 75% GYPSUM, 20% BENTONITE, AND 5% SODIUM SULFATE BACKFILL WITH MANUFACTURER'S STANDARD 10-FOOT LONG, NO. 12 AWG LEAD WIRE.
3. INSTALL ANODES IN PIPE TRENCH APPROXIMATELY 2 FEET FROM THE FITTING WHERE POSSIBLE, BUT NOT CLOSER THAN 12-INCHES FROM THE METALLIC FITTING.
4. ANODE PLACEMENT IS INDICATED BY NUMBER NEXT TO EACH ANODE SHOWN IN DETAILS, FIRST ANODE IS PLACED AT ONE, SECOND AT TWO, ETC.
5. LOCATE MULTIPLE ANODES AT EQUAL SPACING ALONG PIPE FITTING ASSEMBLY AND ON OPPOSITE SIDES OF PIPE WHEN MORE THAN FOUR ANODES ARE REQUIRED.
6. 32-LB GALVANIC ANODES MAY BE SUBSTITUTED FOR 17-LB ANODES AT THE CONTRACTOR'S OPTION, BUT THE TOTAL QUANTITY OF ANODES REQUIRED WILL NOT CHANGE.
7. ANODE QUANTITY AND BARE WEIGHT REQUIRED FOR SOME PIPE AND FITTING COMBINATIONS ARE LISTED IN THE SCHEDULE.
8. ADDITIONAL ANODES ARE REQUIRED ON METALLIC PIPE ASSEMBLIES THAT EXCEED THE MAXIMUM COMBINED LENGTH LISTED IN THE SCHEDULE FOR ALL FITTINGS, VALVES, PIPE SPOOLS, AND OTHER METALLIC APPURTENANCES IN THE ASSEMBLY, EXCLUDING THRUST RESTRAINT, ADD ONE ANODE FOR EACH EXTRA PIPE LENGTH AND ONE ANODE FOR FRACTIONAL EXTRA PIPE LENGTH TO THE LISTED QUANTITY OF ANODES.
9. PIPE ASSEMBLIES FOR BLOW-OFFS, AIR RELEASE, AND FIRE HYDRANTS ARE BASED ON STANDARD CONSTRUCTION DETAILS AND INCLUDES ONE RESTRAINED MAINLINE TEE FITTING AND ALL OFFSET PIPE, FITTINGS, AND RISERS AS SHOWN ON THE APPLICABLE CONSTRUCTION DETAILS, ADDITIONAL ANODES ARE REQUIRED FOR - 1) OFFSET PIPE LENGTH IN EXCESS OF THE MAXIMUM COMBINED LENGTH FOR THE OFFSET PIPE DIAMETER, AND 2) ADDITIONAL ANODES REQUIRED FOR EXTRA MAINLINE PIPE FITTINGS.
10. BOND ALL ADJACENT FITTING JOINTS WHERE MULTIPLE METALLIC FITTINGS ARE INSTALLED TOGETHER WITH JOINT BONDS AS SHOWN IN DETAIL 711-L,M,N.
11. BOND WIRES SHALL BE STRANDED COPPER WIRE WITH THHN INSULATION, USE NO. 2 AWG WIRE FOR BONDING OF PIPE OR FITTING JOINTS, USE NO. 8 AWG WIRE FOR BONDING FOLLOWER RINGS AND RESTRAINED JOINT RINGS TO FITTING AS SHOWN.
12. COAT ALL THERMITE WELDS, PIPE, AND EXPOSED COPPER WIRE WITH SCOTCHKOTE 206P THERMOPLASTIC PATCH MELT STICK COATING, THERMITE WELD CAP, OR COATING SYSTEM AS SPECIFIED.

 PARK CITY MUNICIPAL CORPORATION WATER	DATE	METALLIC PIPE APPURTENANCE AND FITTING CATHODIC PROTECTION	STD. PLAN
	4/2014		537-G.2
	REV.		
	0		

13. COATING MATERIAL FOR METALLIC PIPE AND FITTINGS

A. GENERAL:

- 1. ALL METALLIC FITTINGS AND METALLIC HARDWARE ASSOCIATED WITH NON-METALLIC PIPE CONSTRUCTION SHALL BE DIELECTRICALLY COATED WITH A BONDED COATING.
- 2. PREPARE SURFACE OF ITEMS TO BE COATED IN ACCORDANCE WITH COATING MANUFACTURER'S REQUIREMENTS.

B. DIELECTRIC COATING SYSTEMS FOR METALLIC PIPE, FITTINGS, AND APPURTENANCES

1. WAX TAPE COATING SYSTEM

- a. METALLIC PIPING, FITTINGS, AND APPURTENANCES SHALL BE COATED IN ACCORDANCE WITH AWWA C217.
- b. APPLY COATING SYSTEM TO ALL BURIED METALLIC PIPE APPURTENANCES, INCLUDING JOINTS, FITTINGS, BOLTS, AND IRREGULARLY SHAPED SURFACES.
- c. FILLER MATERIAL:
 - (1) SHALL BE COMPRISED OF SATURATED PETROLEUM HYDROCARBONS (PETROLATUM) INERT FILLERS, REINFORCING FIBERS AND THERMAL EXTENDERS. VARIATIONS MAY CONTAIN BEADS OF CELLULAR POLYMER AND FLOW CONTROL ADDITIVES.
 - (2) WAX SHALL BE COLD APPLIED SELF SUPPORTING MASTICS FOR MOLDING AROUND IRREGULAR SHAPED FITTINGS TO PROVIDE A SUITABLE PROFILE FOR APPLYING ANTI-CORROSION TAPES.
- d. TAPE COATING
 - (1) COMPOSED OF A NON-WOVEN SYNTHETIC FABRIC CARRIER, FULLY IMPREGNATED WITH A NEUTRAL COMPOUND BASED ON SATURATED PETROLEUM COMPOSED OF INERT SILICEOUS FILLERS. APPLY COATING IN ACCORDANCE WITH AWWA C217, EXCEPT AS MODIFIED HEREIN.
- e. PROTECTIVE OUTER WRAP
 - (1) PROVIDE FIBER MESH FABRIC OUTER WRAP OVER WAX TAPE RESIN COATED, WOVEN FIBER-MESH FABRIC THAT IS .005 INCHES.
- f. ALL COMPONENTS OF THE WAX TAPE COATING SYSTEM SHALL BE FROM A SINGLE MANUFACTURER AS MANUFACTURED BY DENSO NORTH AMERICAN, TRENTON, OR EQUAL.

 PARK CITY MUNICIPAL CORPORATION WATER	DATE	METALLIC PIPE APPURTENANCE AND FITTING CATHODIC PROTECTION	STD. PLAN
	4/2014		537-G.3
	REV.		
	0		

SCHEDULE OF ANODE QUANTITIES AND BARE WEIGHT

PIPE AND FITTINGS DESCRIPTIONS	MAX. COMBINED LENGTH	PIPELINE DIAMETER			REFERENCE DETAIL
		6"-10"	12"-18"	20"-24"	
ONE JOINT RESTRAINT	0'	1 @ 17#	1 @ 17#	1 @ 17#	A
ONE FITTING W/O RESTRAINT	0'	1 @ 17#	1 @ 17#	1 @ 17#	A
ONE FITTING W/ RESTRAINT	0'	1 @ 17#	1 @ 17#	1 @ 17#	B
ONE FLEXIBLE COUPLING	0'	1 @ 17#	1 @ 17#	1 @ 17#	A
3"-6" AIR RELEASE ASSEMBLY	20'	2 @ 17#	3 @ 17#	4 @ 17#	D
6" BLOW-OFF PIPE ASSEMBLY	20'	2 @ 17#	3 @ 17#	4 @ 17#	D
6" OR 8" FIRE HYDRANT	20'	2 @ 17#	3 @ 17#	4 @ 17#	D
BURIED MAINLINE VALVE	10'	1 @ 17#	1 @ 17#	2 @ 17#	C
MULTIPLE FITTINGS	10'	1 @ 17#	2 @ 17#	2 @ 17#	C
VALVED TURNOUT	0'	1 @ 17#	2 @ 17#	2 @ 17#	E
<u>EXTRA PIPE LENGTH:</u>					
1-17 LB ANODE FOR		30 FT	15 FT	10 FT	
<u>EXTRA FITTING LENGTH:</u>					
2-17 LB ANODES FOR		20 FT	12 FT	8 FT	



PARK CITY MUNICIPAL CORPORATION
WATER

DATE

4/2014

REV.

0

METALLIC PIPE APPURTENANCE AND FITTING CATHODIC PROTECTION

STD. PLAN

537-G.4

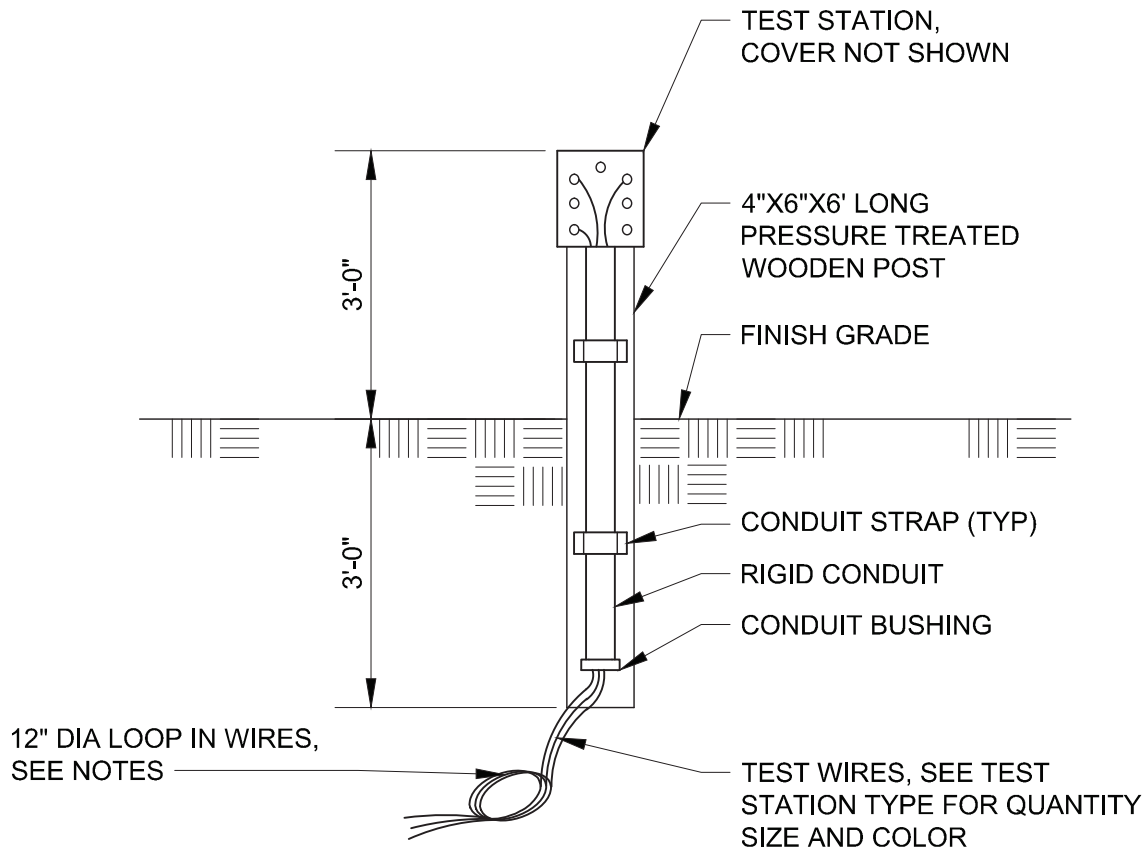

NOTES:

1. TEST STATION TO BE ALUMINUM BODY AND LID WITH THREADED CONNECTION FOR CONDUIT.
2. QUANTITY OF TERMINALS AND WIRING CONNECTIONS VARIES, SEE APPLICABLE TEST STATION DETAILS FOR TYPE OF TEST STATION.
3. PROVIDE WIRE LOP AT BASE OF POST MOUNTED TEST STATION TO MINIMIZE SETTLEMENT STRESSES ON WIRE.



PARK CITY MUNICIPAL CORPORATION
WATER

DATE

03/2014

REV.

0

**POST STYLE TEST STATION
WOOD**

STD. PLAN

538-A

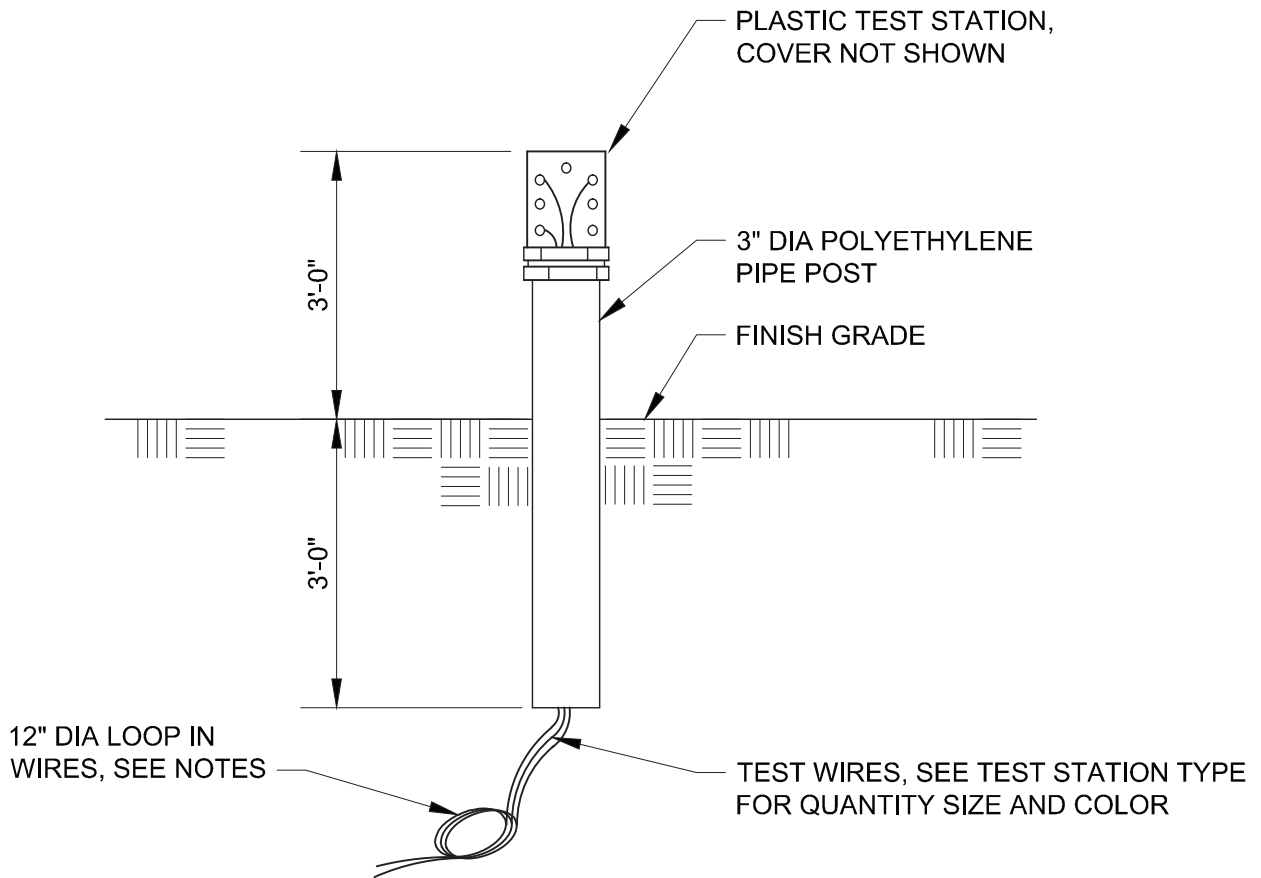

NOTES:

1. COLOR OR TEST STATION AND POST AS SPECIFIED.
2. QUANTITY OF TERMINALS AND WIRING CONNECTIONS VARIES, SEE APPLICABLE TEST STATION DETAILS FOR TYPE OF TEST STATION.
3. PROVIDE WIRE LOP AT BASE OF POST MOUNTED TEST STATION TO MINIMIZE SETTLEMENT STRESSES ON WIRE



PARK CITY MUNICIPAL CORPORATION
WATER

DATE

03/2014

REV.

0

**POST STYLE TEST STATION
 PLASTIC**

STD. PLAN

538-B

2'-6" X 6" THICK FORMED
CONCRETE PAD

8" DIA CAST IRON COVER
MARKED "TEST STATION"

MICARTA BOARD WITH
SST TERMINALS, SEE
STD. PLAN 538-D

12" METER BOX, PROVIDE
EXTENSION WHERE
SPECIFIED, EXTENSION
NOT SHOWN

TEST WIRES, NOT ALL SHOWN

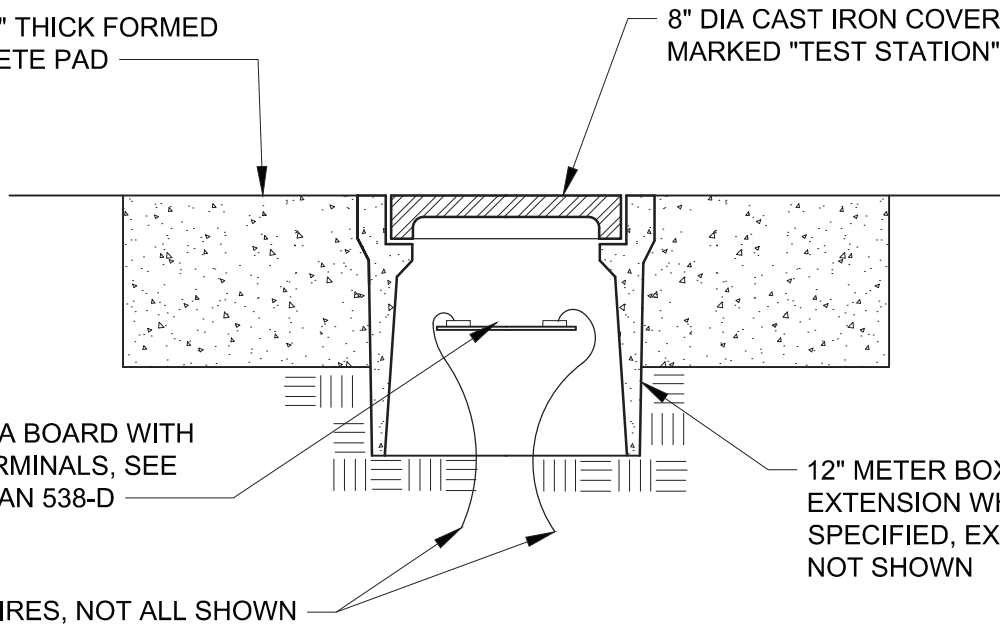

NOTES:

1. COLOR CODE WIRE INSULATION AS SHOWN IN APPLICABLE TEST STATION DETAILS, CONNECT EACH TEST WIRE TO SEPARATE TERMINAL.
2. WIRE CONFIGURATION FOR FLUSH MOUNTED TEST STATIONS SIMILAR TO POST MOUNTED TEST STATIONS.
3. PROVIDE 18 INCHES SLACK IN TEST WIRES, MINIMUM.



PARK CITY MUNICIPAL CORPORATION
WATER

DATE

03/2014

REV.

0

**FLUSH STYLE
TEST STATION BOX**

STD. PLAN

538-C

CONNECT #8 AWG ANODE LEAD, IF THERE ARE NO ANODES THIS CONNECTION POINT SHALL BE A SPARE

0.01 OHM HOLLOWAY SHUNT, REQUIRED AT TYPE A TEST STATIONS ONLY

SPARE

MICARTA BOARD

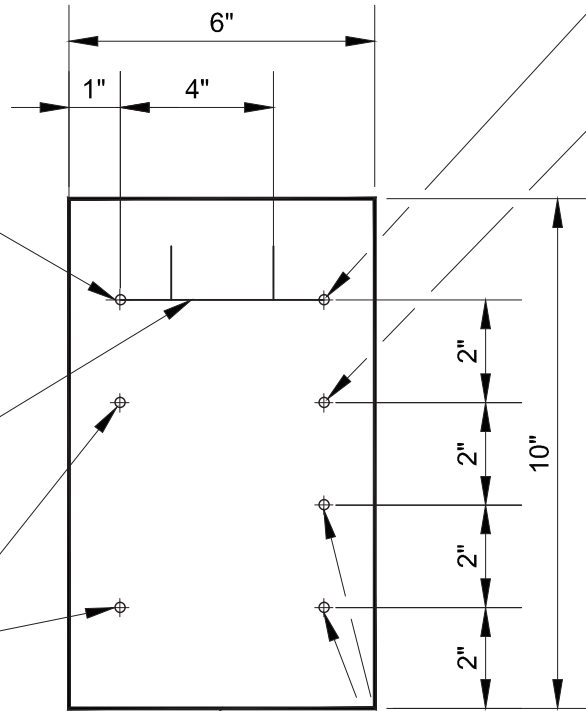

CONNECT #8 OR #12 AWG PIPE TEST WIRE, WHITE

CONNECT #12 AWG PIPE TEST WIRE, WHITE

CONNECT FOREIGN PIPE, CASING, OR UNPROTECTED INSULATING FLANGE TEST WIRES

NOTES:

1. TERMINALS SHALL BE 1/4" STAINLESS STEEL WITH LOCKING WASHER, TWO FLAT WASHERS, AND DOUBLE NUTS.
2. ALL WIRE CONNECTIONS TO BE WITH RING TONGUE COMPRESSION TERMINALS.



PARK CITY MUNICIPAL CORPORATION
WATER

DATE

02/2014

REV.

0

**FLUSH STYLE TEST STATION
TERMINAL BOARD**

STD. PLAN

538-D

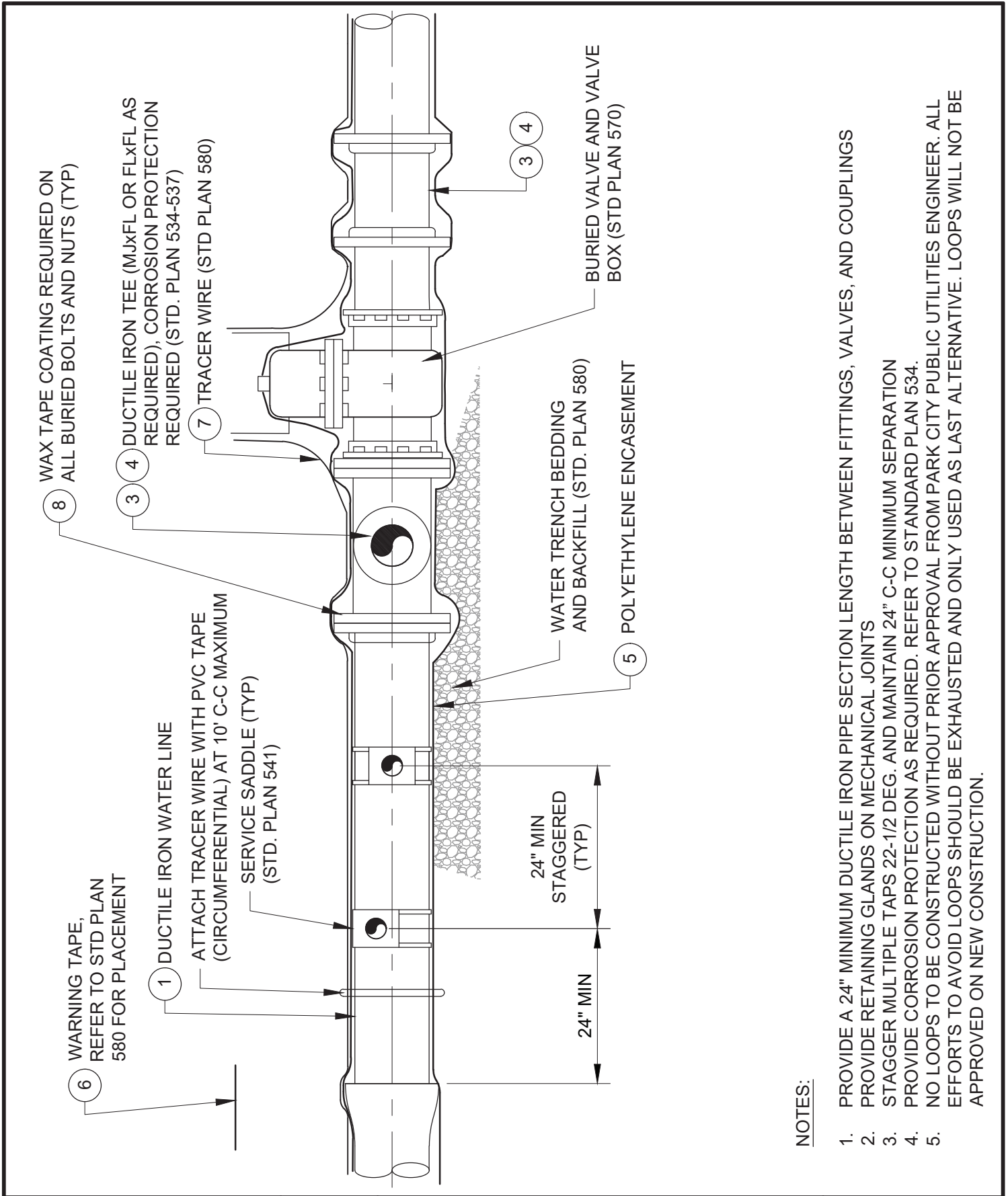

NOTES:

1. PROVIDE A 24" MINIMUM DUCTILE IRON PIPE SECTION LENGTH BETWEEN FITTINGS, VALVES, AND COUPLINGS
2. PROVIDE RETAINING GLANDS ON MECHANICAL JOINTS
3. STAGGER MULTIPLE TAPS 22-1/2 DEG. AND MAINTAIN 24" C-C MINIMUM SEPARATION
4. PROVIDE CORROSION PROTECTION AS REQUIRED. REFER TO STANDARD PLAN 534.
5. NO LOOPS TO BE CONSTRUCTED WITHOUT PRIOR APPROVAL FROM PARK CITY PUBLIC UTILITIES ENGINEER. ALL EFFORTS TO AVOID LOOPS SHOULD BE EXHAUSTED AND ONLY USED AS LAST ALTERNATIVE. LOOPS WILL NOT BE APPROVED ON NEW CONSTRUCTION.

 PARK CITY MUNICIPAL CORPORATION WATER	DATE	<h2 style="margin: 0;">WATER MAIN DUCTILE IRON PIPE 4" TO 12" DIAMETER</h2>	STD. PLAN
	03/2024		<h1 style="margin: 0;">540-A</h1>
	REV.		
	2		

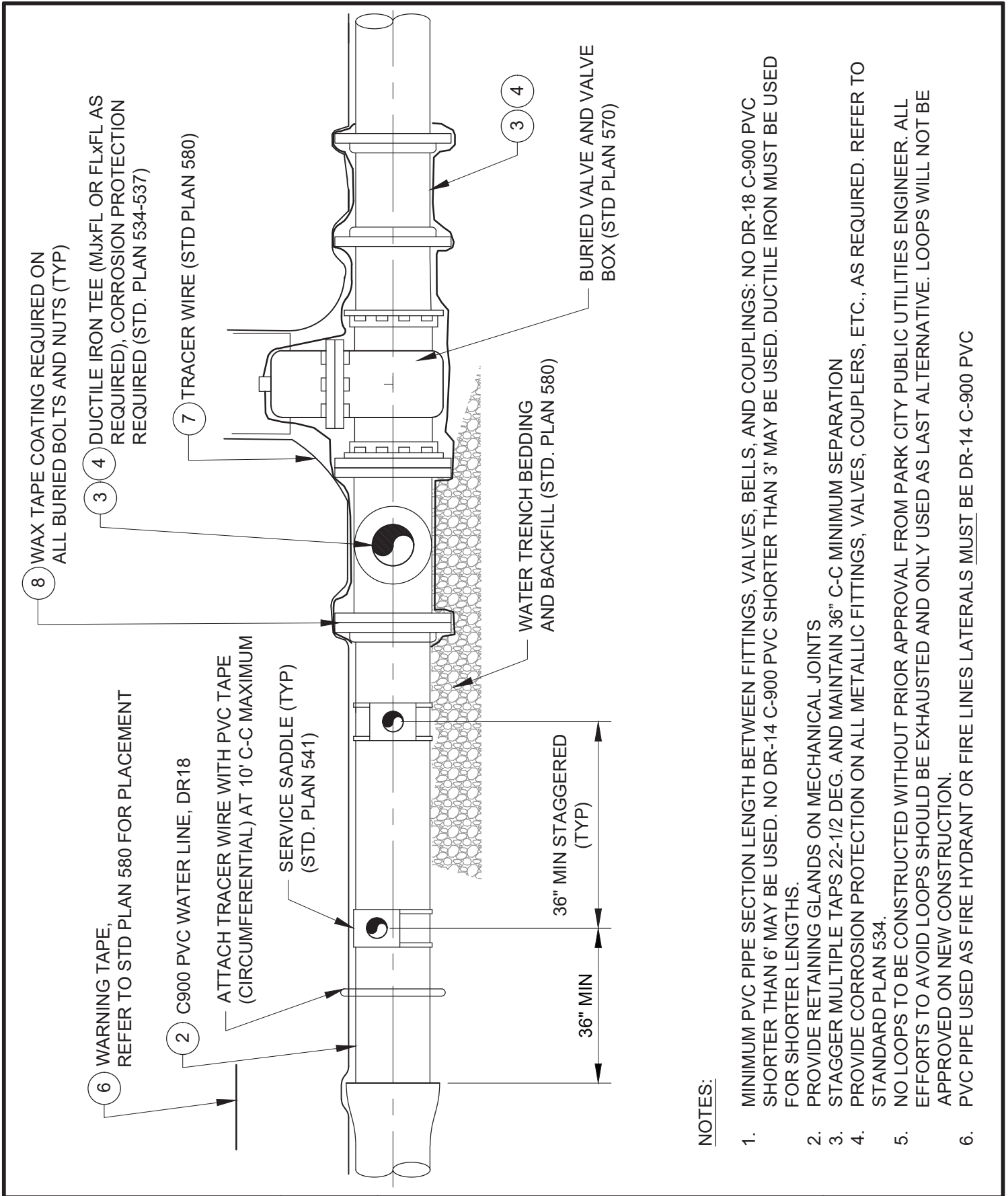

NOTES:

1. MINIMUM PVC PIPE SECTION LENGTH BETWEEN FITTINGS, VALVES, BELLS, AND COUPLINGS: NO DR-18 C-900 PVC SHORTER THAN 6' MAY BE USED. NO DR-14 C-900 PVC SHORTER THAN 3' MAY BE USED. DUCTILE IRON MUST BE USED FOR SHORTER LENGTHS.
2. PROVIDE RETAINING GLANDS ON MECHANICAL JOINTS
3. STAGGER MULTIPLE TAPS 22-1/2 DEG. AND MAINTAIN 36" C-C MINIMUM SEPARATION
4. PROVIDE CORROSION PROTECTION ON ALL METALLIC FITTINGS, VALVES, COUPLERS, ETC., AS REQUIRED. REFER TO STANDARD PLAN 534.
5. NO LOOPS TO BE CONSTRUCTED WITHOUT PRIOR APPROVAL FROM PARK CITY PUBLIC UTILITIES ENGINEER. ALL EFFORTS TO AVOID LOOPS SHOULD BE EXHAUSTED AND ONLY USED AS LAST ALTERNATIVE. LOOPS WILL NOT BE APPROVED ON NEW CONSTRUCTION.
6. PVC PIPE USED AS FIRE HYDRANT OR FIRE LINES LATERALS MUST BE DR-14 C-900 PVC

 PARK CITY MUNICIPAL CORPORATION WATER	DATE	WATER MAIN - PVC PIPE 4" TO 12" DIAMETER	STD. PLAN
	03/2024		540-B
REV.	2		

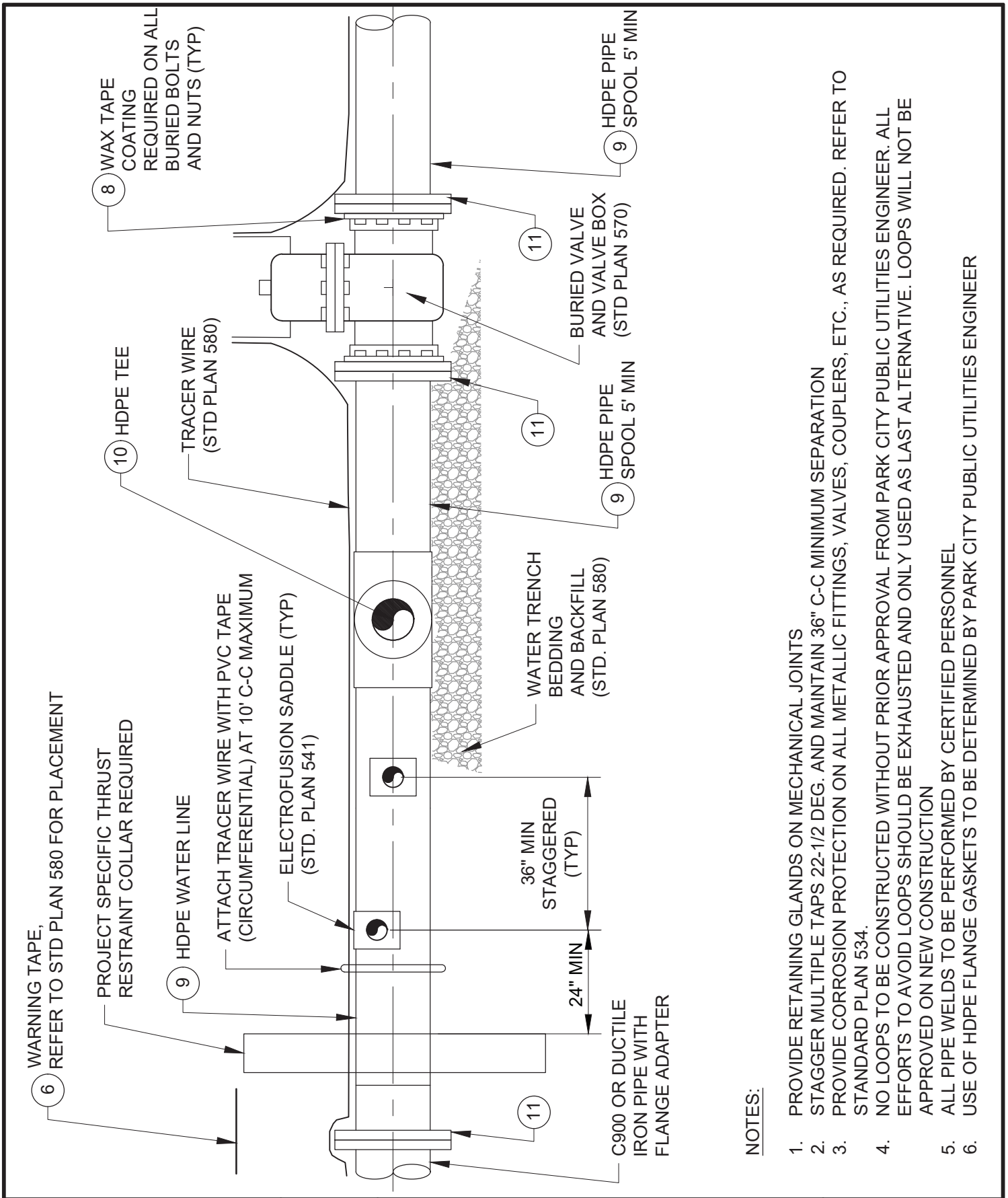

NOTES:

1. PROVIDE RETAINING GLANDS ON MECHANICAL JOINTS
2. STAGGER MULTIPLE TAPS 22-1/2 DEG. AND MAINTAIN 36" C-C MINIMUM SEPARATION
3. PROVIDE CORROSION PROTECTION ON ALL METALLIC FITTINGS, VALVES, COUPLERS, ETC., AS REQUIRED. REFER TO STANDARD PLAN 534.
4. NO LOOPS TO BE CONSTRUCTED WITHOUT PRIOR APPROVAL FROM PARK CITY PUBLIC UTILITIES ENGINEER. ALL EFFORTS TO AVOID LOOPS SHOULD BE EXHAUSTED AND ONLY USED AS LAST ALTERNATIVE. LOOPS WILL NOT BE APPROVED ON NEW CONSTRUCTION
5. ALL PIPE WELDS TO BE PERFORMED BY CERTIFIED PERSONNEL
6. USE OF HDPE FLANGE GASKETS TO BE DETERMINED BY PARK CITY PUBLIC UTILITIES ENGINEER

 PARK CITY MUNICIPAL CORPORATION WATER	DATE	WATER MAIN - HDPE PIPE 4" TO 16" DIAMETER	STD. PLAN
	03/2024		540-C
	REV.		
0			

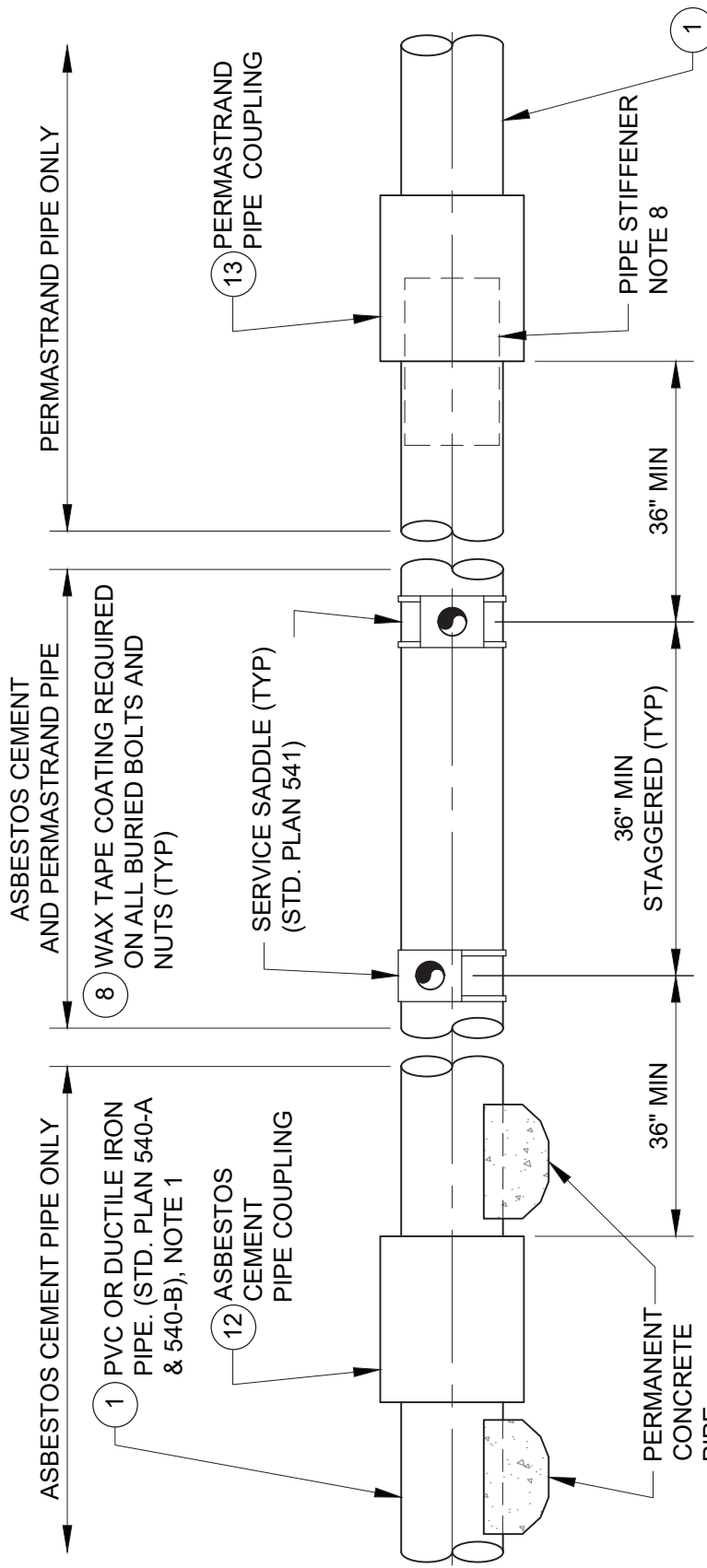

PVC OR DUCTILE IRON PIPE. (STD. PLAN 540-A & 540-B), NOTE 1

NOTES:

1. MINIMUM PVC PIPE SECTION LENGTH BETWEEN FITTINGS, VALVES, COUPLINGS, AND BELLS: NO DR-18 C-900 PVC SHORTER THAN 6' MAY BE USED. NO DR-14 C-900 PVC SHORTER THAN 3' MAY BE USED. DUCTILE IRON MUST BE USED FOR SHORTER LENGTHS.
2. PROVIDE RETAINING GLANDS ON MECHANICAL JOINTS
3. STAGGER MULTIPLE TAPS 22-1/2 DEG. AND MAINTAIN 36" C-C MINIMUM SEPARATION
4. PROVIDE CORROSION PROTECTION ON ALL METALLIC FITTINGS, VALVES, COUPLERS, ETC., AS REQUIRED. REFER TO STANDARD PLAN 534.
5. NO LOOPS TO BE CONSTRUCTED WITHOUT PRIOR APPROVAL FROM PARK CITY PUBLIC UTILITIES ENGINEER. ALL EFFORTS TO AVOID LOOPS SHOULD BE EXHAUSTED AND ONLY USED AS LAST ALTERNATIVE. LOOPS WILL NOT BE APPROVED ON NEW CONSTRUCTION
8. STIFFENERS FOR PERMASTRAND PIPE TO BE PROVIDED BY PARK CITY PUBLIC UTILITIES.
9. PERMANENT POURED CONCRETE PIPE SUPPORTS TO BE APPROVED AND INSPECTED BY PARK CITY PUBLIC UTILITIES ENGINEER.



PARK CITY MUNICIPAL CORPORATION
WATER

DATE	03/2024
REV.	0

CONNECTION TO EXISTING WATER MAIN - ASBESTOS CEMENT & PERMASTRAND PIPE 4" TO 12" DIAMETER

STD. PLAN
540-D

LEGEND AND APPROVED PARTS LIST

ITEM	DESCRIPTION	ACCEPTABLE MANUFACTURER	MODELS
①	DUCTILE IRON PIPE, 4" TO 12" DIAMETER, PRESSURE CLASS 350, CEMENT-MORTAR LINING, ASPHALTIC INTERIOR/EXTERIOR COATING, AWWA C150 / C151 / C104	U.S. PIPE (1) PACIFIC STATES	<u>STANDARD JOINT PIPE:</u> PUSH ON TYTON JOINT
		U.S. PIPE (1) PACIFIC STATES	<u>RESTRAINED JOINT PIPE:</u> THRUST-LOCK TR FLEX
②	POLYVINYL CHLORIDE (PVC) PIPE, C.I.O.D., C900, DR 18, INTEGRAL BELL JOINT (ALLOWABLE SIZE 8" – 12")	JM EAGLE (1)	<u>STANDARD JOINT PIPE:</u> BLUE BRUTE
③	DUCTILE IRON FITTINGS, 4" TO 12" DIAMETER, FULL BODY, PRESSURE CLASS 350, CEMENT MORTAR LINED, ASPHALTIC EXTERIOR COATING, AWWA C153 / C104 FLANGES: AWWA C110 / C115, CLASS 125 FLANGE WITH FULL FACE OR RING FLANGE-TYTE GASKETS	U.S. PIPE (1) PACIFIC STATES	<u>PUSH ON STYLE FITTING:</u> TYTON JOINT <u>FLANGED FITTING:</u>
		U.S. PIPE (1) PACIFIC STATES	<u>RESTRAINED JOINT PIPE:</u> THRUST-LOCK TR FLEX
④	FITTINGS – DUCTILE IRON MECHANICAL JOINT PIPE WITH RETAINER GLANDS OR SST TIE ROD / NUT RESTRAINTS, AWWA C110 / C111 / C104	EBBA IRON (1)	<u>FITTINGS:</u> MECHANICAL JOINT <u>RETAINER GLANDS:</u> MEGALUG SERIES 1100, STD T-BOLTS AND NUTS
⑤	V-BIO ENHANCED POLYETHYLENE ENCASEMENT, AWWA C105 & AWWA C703E METHODS A & C	MCWANE (1)	AWWA C703E METHOD A (4 MIL) AT PIPE AND AWWA C703E METHOD C (10 MIL) AT BOLT-TYPE JOINTS, FITTINGS, AND VALVES
⑥	DETECTABLE UNDERGROUND WARNING TAPE, 5-MIL MINIMUM, ALUMINUM BACKING, BLUE BACKGROUND, 6" WIDE	SETON (1)	85525
⑦	TRACER WIRE: 12 GA. SOLID, BLUE PVC INSULATION; WIRE-WIRE CONNECTORS SILICONE-FILLED WIRE NUTS	CONNECTORS: IDEAL INDUSTRIES (1)	TWISTER DB PLUS OR APP'D EQUAL
⑧	WAX TAPE COATING SYSTEM, APPLY TO <u>ALL</u> BURIED BOLTS AND NUTS INCLUDING MECHANICAL JOINT RESTRAINT SYSTEMS, AWWA C 217. REFER TO STD. PLAN 534.		
⑨	HDPE 4710 PIPE, 150 PSI MIN WORKING PRESSURE	JM EAGLE (1)	INTEGRAL DOUBLE STRIPE CULINARY: BLUE IRRIGATION: PURPLE
⑩	HDPE 4710 PIPE FITTINGS, 150 PSI MIN WORKING PRESSURE	JM EAGLE (1)	
⑪	HDPE WELD ON FLANGE ADAPTER WITH 316 SST BACKER RING	JM EAGLE (1)	
⑫	AC PIPE COUPLING	HYMAX	2 WIDE-RANGE COUPLING
⑬	PERMASTRAND PIPE COUPLING	ROMAC	MACRO HP COUPLING



PARK CITY MUNICIPAL CORPORATION
WATER

DATE

03/2024

REV.

1

WATER MAIN AND FIRE LINES

STD. PLAN

540 S.1

DETAIL NOTES

1. COORDINATE PIPE SIZE WITH APPROVED PLANS PRIOR TO ORDERING MATERIALS
2. LOCATE MAIN, FITTINGS, VALVES, AND FIRE LINES PER APPROVED PLANS
3. DUCTILE IRON PIPE IS REQUIRED WHEN WATER SYSTEM DESIGN PRESSURE EXCEEDS 200 PRESSURE RATING
4. PROVIDE "DOMESTIC" DUCTILE IRON FITTINGS
5. PROVIDE 316 STAINLESS STEEL BOLTS AND NUTS WITH ANTI-SEIZE LUBRICATION ON ALL FLANGED CONNECTIONS
6. REFER TO STANDARD PLAN 534 FOR SUPPLEMENTAL EXTERNAL CORROSION PROTECTION REQUIREMENTS. WHEN CATHODIC PROTECTION IS REQUIRED REFER TO STD. PLANS 534-538.
7. REFER TO SPECIFICATIONS FOR FLUSHING, HYDROSTATIC TESTING, AND DISINFECTING REQUIREMENTS
8. (1) DENOTES "OR APPROVED EQUAL" MANUFACTURER AND MODEL. SUBMIT IN ACCORDANCE WITH CITY STANDARDS

 PARK CITY MUNICIPAL CORPORATION WATER	DATE	WATER MAIN AND FIRE LINES	STD. PLAN
	03/2024		540 S.2
	REV.		
	1		

NOTES:

1. REFERENCE STD. PLAN 520 FOR GENERAL REQUIREMENTS - METER, METER VAULT, AND SERVICE LINE.

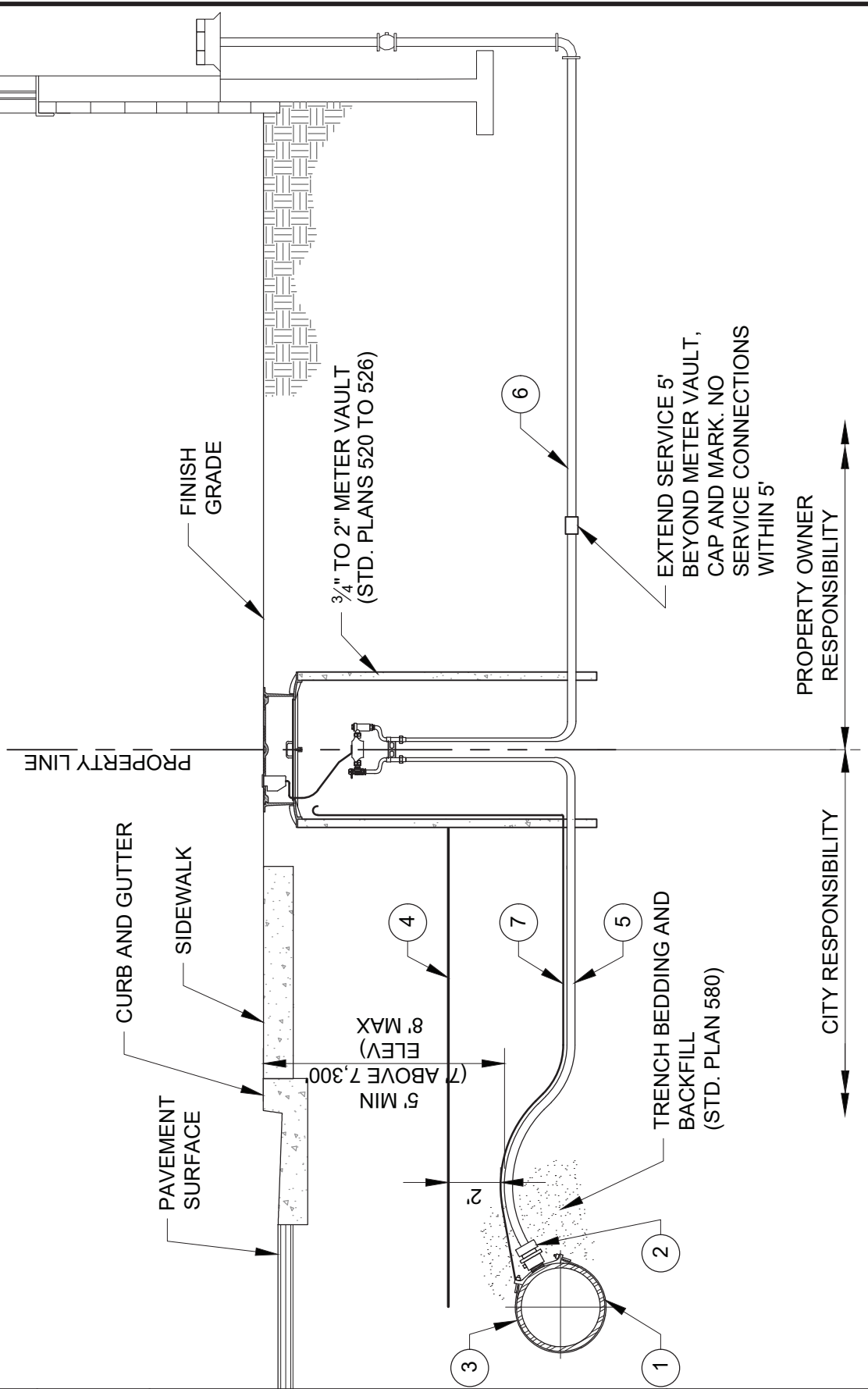

PARK CITY MUNICIPAL CORPORATION
WATER

DATE

03/2024

REV.

2

**WATER SERVICE LINE
3/4" TO 2" METERS**

STD. PLAN

541

LEGEND AND APPROVED PARTS LIST

ITEM	DESCRIPTION	ACCEPTABLE MANUFACTURER	MODELS
①	SERVICE SADDLE: <ul style="list-style-type: none"> • DUCTILE IRON (DI) PIPE; DUAL STRAP • PVC PIPE; DUAL STRAP • ASBESTOS CEMENT (AC) PIPE; DUAL STRAP • PERMASTRAND PIPE; DUAL STRAP • HDPE PIPE; ELECTROFUSION 	POWERSEAL	DI, PVC, AC & PERMASTRAND PIPE; STAINLESS STEEL SADDLECORP, 3450AS-POWERJOINT, 2" SERVICE
		ROMAC	PVC, AC & PERMASTRAND PIPE; STYLE 202NS DUAL STAINLESS STEEL STRAPS, 2" SERVICE, FIP THDS
		FORD	DI PIPE; BRONZE, STYLE 202B, 2" SERVICE, FIP THDS
		ISCO OR APPV'D EQUAL	HDPE PIPE; 2" SERVICE, BY APPROVAL
②	BRASS CORPORATION STOP, INLET IP THREAD, OUTLET CTS COMPRESSION	MUELLER	B-25008N
		FORD	FB1100-2-Q-NL
③	V-BIO ENHANCED POLYETHYLENE ENCASEMENT, AWWA C105 & AWWA C703E METHOD C	MCWANE OR APPV'D EQUAL	AWWA C703E METHOD C (4 MIL)
④	DETECTABLE UNDERGROUND WARNING TAPE, 5-MIL MINIMUM, ALUMINUM BACKING BLUE BACKGROUND, 6" WIDE	SETON OR APPV'D EQUAL	85525
⑤	2" WATER SERVICE LINE: HIGH-DENSITY POLYETHYLENE TUBING (CTS), BLUE, SDR 9, AWWA C901	ADS OR APPV'D EQUAL	
⑥	WATER SERVICE LINE: HIGH-DENSITY POLYETHYLENE TUBING (CTS), BLUE, SDR 9, AWWA C901	ADS OR APPV'D EQUAL	
⑦	TRACER WIRE: 12 GA. SOLID, BLUE PVC INSULATION; WIRE-WIRE CONNECTORS SILICONE-FILLED WIRE NUTS	IDEAL INDUSTRIES	TWISTER DB PLUS OR APP'D EQUAL

DETAIL NOTES

1. COORDINATE SERVICE SIZE WITH CITY PRIOR TO ORDERING MATERIALS
2. LOCATE SERVICE PER APPROVED PLANS
3. NO SERVICE LINE FITTINGS ALLOWED BETWEEN CORPORATION STOP AND METER VAULT CURB STOP VALVE
4. APPLY WAX TAPE COATING SYSTEM TO SERVICE SADDLE BOLTS AND NUTS, AWWA C217. SYSTEM TO INCLUDE FILLER MATERIAL, TAPE COATING, AND PROTECTIVE OUTERWRAP. DENSO NORTH AMERICA, TRENTON, OR APPROVED EQUAL (STD. PLAN 534)

 PARK CITY MUNICIPAL CORPORATION WATER	DATE	<h2 style="margin: 0;">WATER SERVICE LINE</h2> <h3 style="margin: 0;">3/4" TO 2" METERS</h3>	STD. PLAN
	03/2024		541 S
	REV.		
	2		

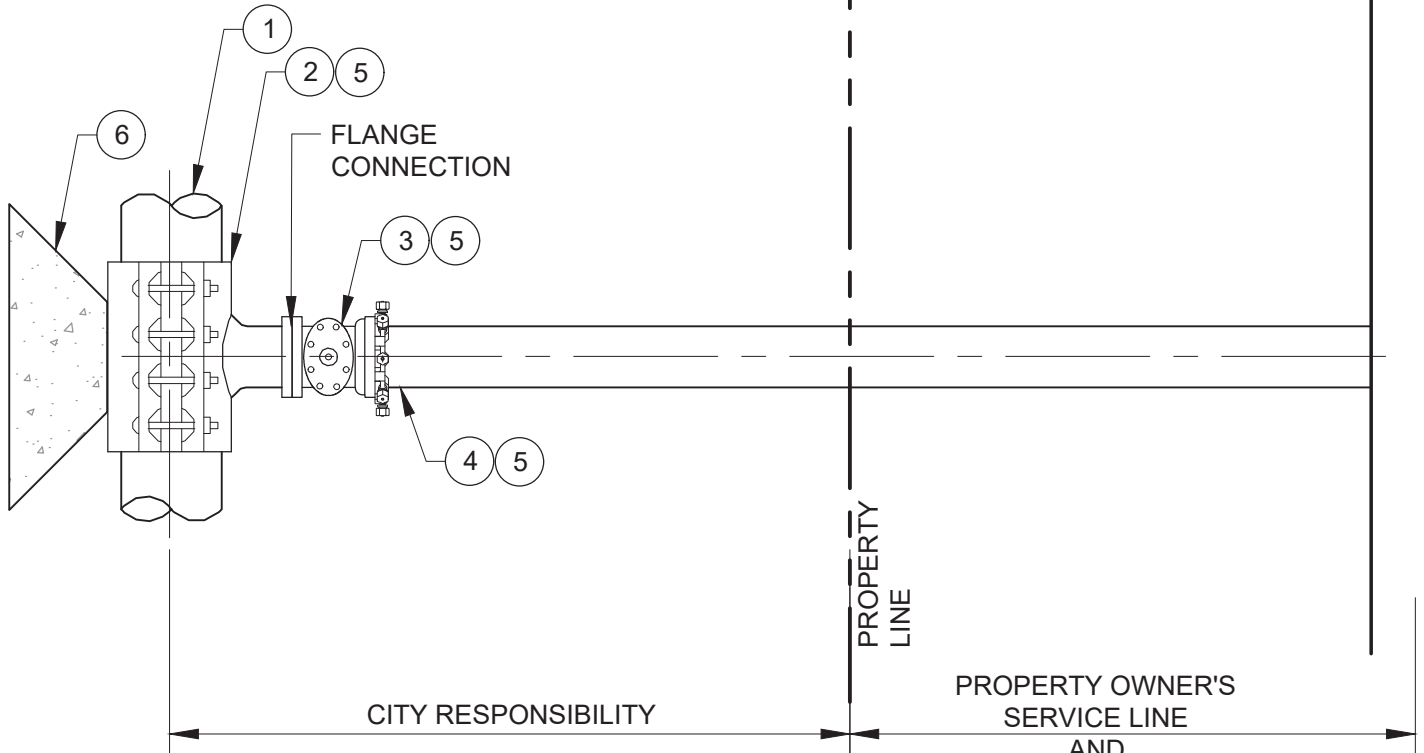

4" AND LARGER

LEGEND	
ITEM	DESCRIPTION
①	EXISTING MAIN
②	STAINLESS STEEL TAPPING SLEEVE (NOT ALLOWED IN NEW CONSTRUCTION)
③	TAPPING VALVE OR FLG X MJ GATE VALVE (STD PLAN 570 AND 572)
④	POLYVINYL CHLORIDE (PVC) PIPE, C.I.O.D., C900, DR 14, INTEGRAL BELL JOINT
⑤	POLYETHYLENE WRAPPED (STD. PLAN 540-A)
⑥	THRUST BLOCK (STD. PLAN 561)

NOTES:

- FOR FIRE SERVICE LINES A DOUBLE CHECK VALVE OR REDUCED PRESSURE PRINCIPLE BACKFLOW ASSEMBLY TO BE DETERMINED BY BUILDING AND WATER DEPARTMENTS BASED ON DEGREE OF HAZARD POSED BY FIRE SPRINKLER PROTECTION SYSTEM USE.
- ENTIRE STAINLESS STEEL TAPPING TEE IS TO BE WAX TAPED AS WELL AS THE FLANGE, BOLTS, AND THE VALVE BONET BOLTS (STD. PLAN 534.2)
- NO TAPPING OF SIMILAR SIZED PIPE, TAP MUST BE AT LEAST ONE STANDARD SIZE SMALLER THAN THE WATER MAIN BEING TAPPED
- HOT TAPS MAY BE DENIED FOR ANY REASON SEEN FIT BY PARK CITY WHICH INCLUDE BUT ARE NOT LIMITED TO: PIPE MATERIAL, PIPE CONDITION, AND LOCATION OF PROPOSED HOT TAP
- A HOT TAP REQUEST FORM MUST BE SUBMITTED FOUR BUSINESS DAYS BEFORE THE APPROVED TAP IS TO BE PERFORMED

 PARK CITY MUNICIPAL CORPORATION WATER	DATE	<h2>HOT TAPS 4" AND LARGER</h2>	STD. PLAN
	03/2024		<h1>542</h1>
	REV.		
	2		

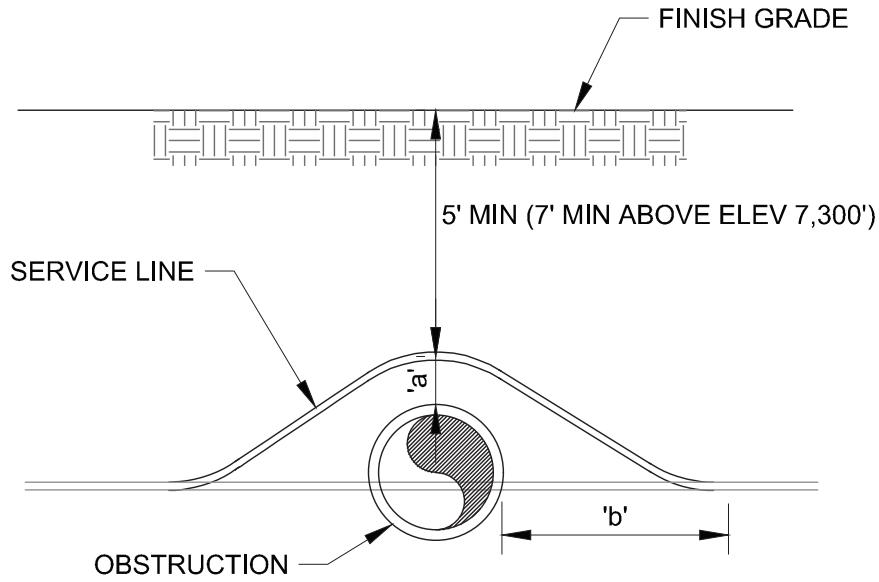

METHOD A

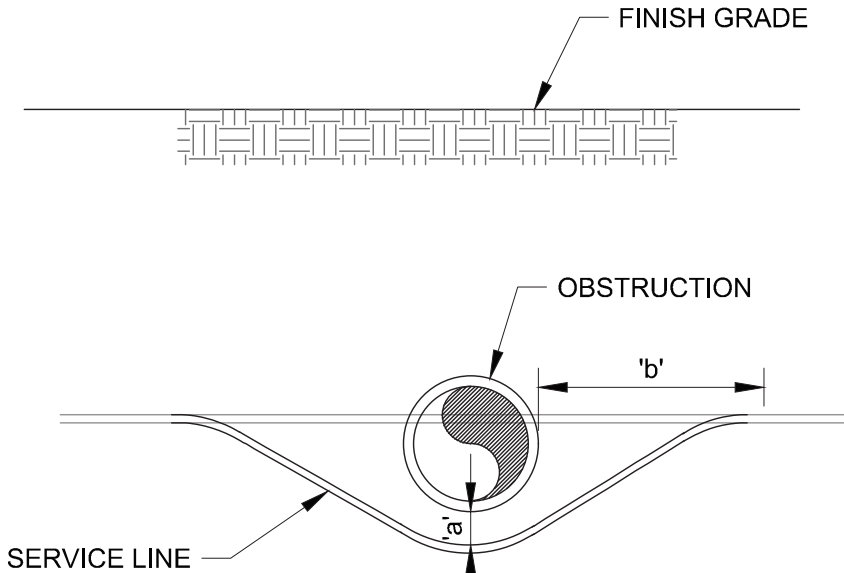

METHOD B

TABLE OF DIMENSIONS

	OBSTRUCTION		
	SEWER MAIN	STORM DRAIN OR CULVERT	OTHER
'a'	18"	SEE STD. PLAN 546	12" MIN
'b'	5'-0"		3'-0" MIN

NOTES:

1. ALL CULINARY WATER MAINS AND LATERALS SHALL BE INSTALLED ABOVE SEWER LINES UNLESS APPROVED BY PARK CITY AND UTAH DIVISION OF DRINKING WATER.



PARK CITY MUNICIPAL CORPORATION
WATER

DATE

6/2019

REV.

1

WATER SERVICE LINE LOOP

STD. PLAN

543

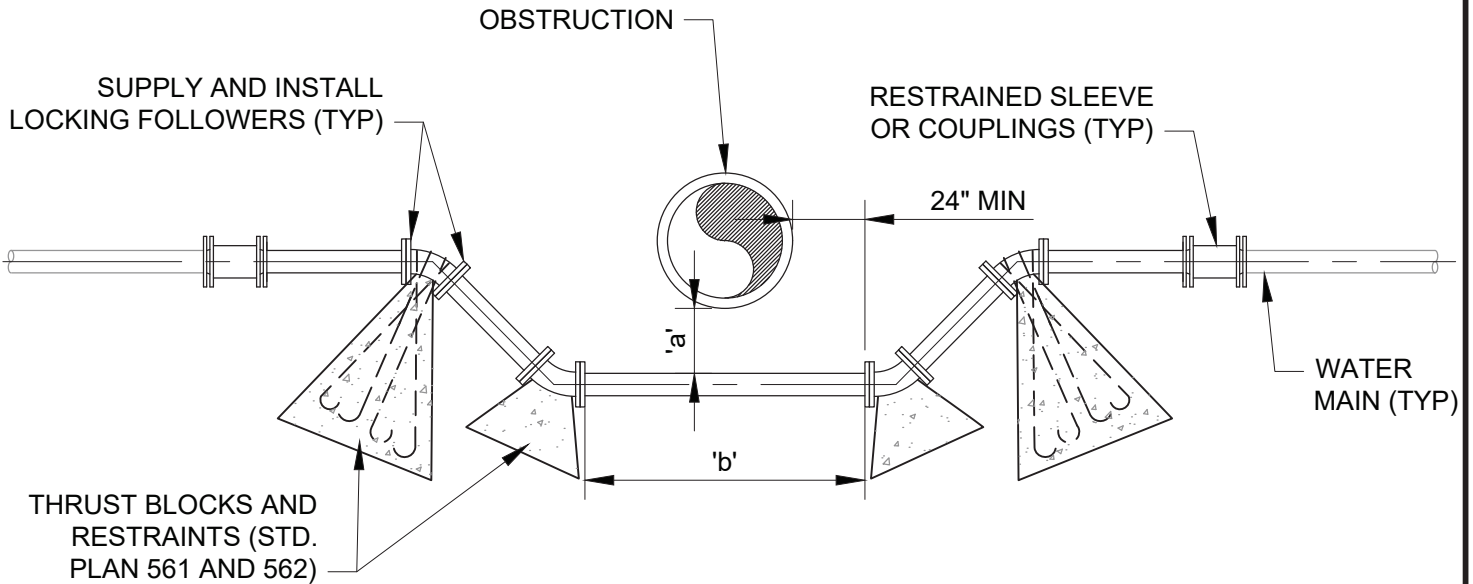

TABLE OF DIMENSIONS		
OBSTRUCTION	'a'	'b'
SEWER	18" MIN	20' MIN
STORM DRAIN OR CULVERT	SEE STD. PLAN 546	O.D. + 6'
OTHER	12" MIN	O.D. + 4'

METHOD A

NOTES:

1. NO LOOPS TO BE CONSTRUCTED WITHOUT PRIOR APPROVAL FROM PARK CITY PUBLIC UTILITIES ENGINEER. ALL EFFORTS TO AVOID LOOPS SHOULD BE EXHAUSTED AND ONLY USED AS LAST ALTERNATIVE. LOOPS WILL NOT BE APPROVED ON NEW CONSTRUCTION.
2. RESTRAINED JOINT PIPE REQUIRED
3. ALL CULINARY WATER MAINS AND LATERALS SHALL BE INSTALLED ABOVE SEWER LINES UNLESS APPROVED BY PARK CITY AND UTAH DIVISION OF DRINKING WATER.

 PARK CITY MUNICIPAL CORPORATION WATER	DATE	WATER MAIN LOOP	STD. PLAN
	03/2024		544-A
	REV.		
	2		

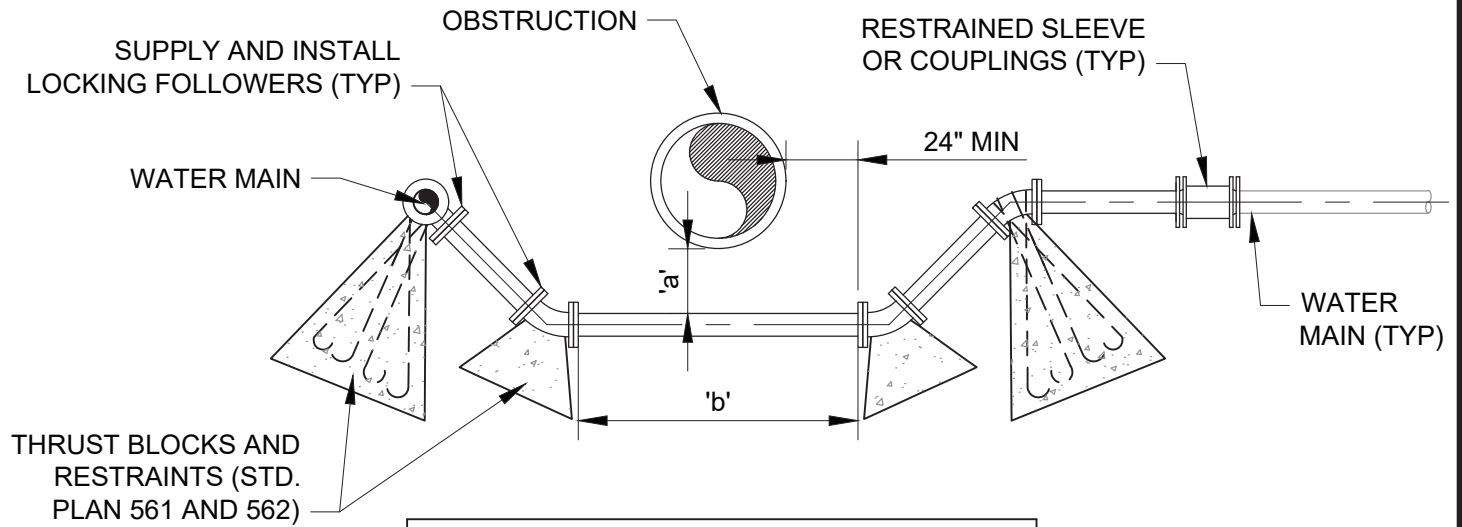

TABLE OF DIMENSIONS		
OBSTRUCTION	'a'	'b'
SEWER	18" MIN	20' MIN
STORM DRAIN OR CULVERT	SEE STD. PLAN 546	O.D. + 6'
OTHER	12" MIN	O.D. + 4'

METHOD B

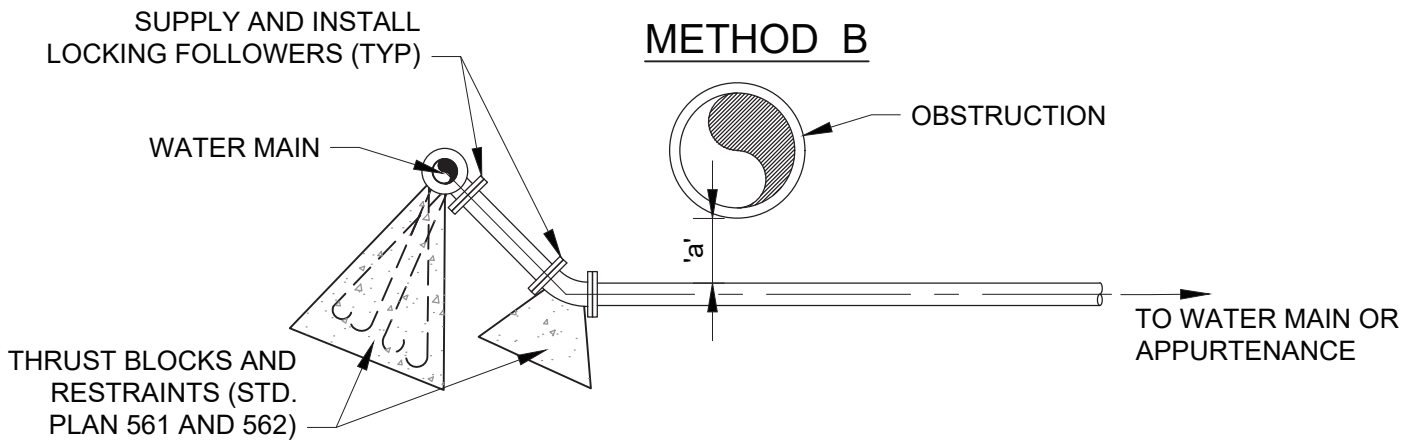

TABLE OF DIMENSIONS	
OBSTRUCTION	'a'
SEWER	18" MIN
STORM DRAIN OR CULVERT	SEE STD. PLAN 546
OTHER	12" MIN

METHOD C

NOTES:

1. NO LOOPS TO BE CONSTRUCTED WITHOUT PRIOR APPROVAL FROM PARK CITY PUBLIC UTILITIES ENGINEER. ALL EFFORTS TO AVOID LOOPS SHOULD BE EXHAUSTED AND ONLY USED AS LAST ALTERNATIVE. LOOPS WILL NOT BE APPROVED ON NEW CONSTRUCTION.
2. RESTRAINED JOINT PIPE REQUIRED
3. ALL CULINARY WATER MAINS AND LATERALS SHALL BE INSTALLED ABOVE SEWER LINES UNLESS APPROVED BY PARK CITY AND UTAH DIVISION OF DRINKING WATER.

 PARK CITY MUNICIPAL CORPORATION WATER	DATE	<h2>WATER MAIN LOOP</h2>	STD. PLAN
	03/2024		<h1>544-B</h1>
	REV.		
	2		

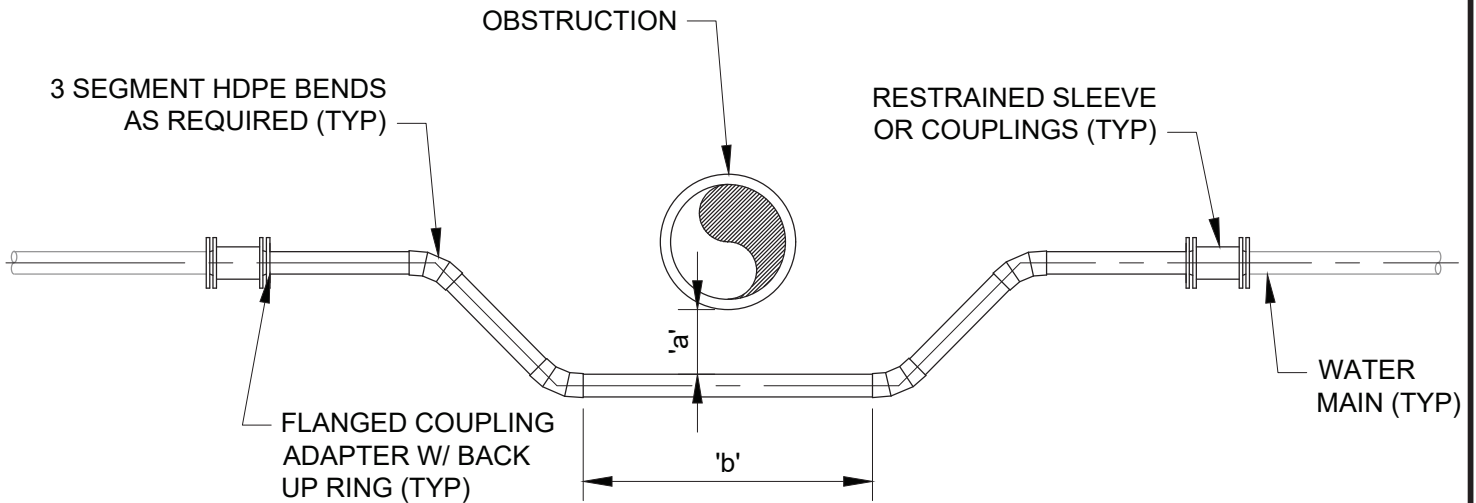

TABLE OF DIMENSIONS		
OBSTRUCTION	'a'	'b'
SEWER	18" MIN	20' MIN
STORM DRAIN OR CULVERT	SEE STD. PLAN 546	O.D. + 6'
OTHER	12" MIN	O.D. + 4'

HDPE METHOD

NOTES:

HDPE PIPE WATERLINE LOOP MINIMUM REQUIREMENTS:

1. NO LOOPS TO BE CONSTRUCTED WITHOUT PRIOR APPROVAL FROM PARK CITY PUBLIC UTILITIES ENGINEER. ALL EFFORTS TO AVOID LOOPS SHOULD BE EXHAUSTED AND ONLY USED AS LAST ALTERNATIVE. LOOPS WILL NOT BE APPROVED ON NEW CONSTRUCTION.
2. GENERAL: PIPE SHALL BE HDPE 4710 DR11 WITH AN INSIDE DIAMETER EQUAL TO OR GREATER THAN THE CONNECTING PIPE ON BOTH ENDS.
3. PIPE SHALL BE FUSION WELDED ALONG LENGTH AND FULLY RESTRAINED AT TRANSITIONS TO DIFFERING PIPE MATERIALS WITH FLANGES OR OTHER CITY APPROVED METHOD.
4. FITTINGS ALONG THE LOOP LENGTH SHALL BE HDPE UNLESS OTHERWISE APPROVED BY OWNER.
5. BENDING RADIUS NOT TO EXCEED PIPE MANUFACTURES RECOMMENDATIONS.
6. REDUCERS AND TRANSITION COUPLINGS SHALL BE PROVIDED ON BOTH ENDS AS REQUIRED AND SHALL BE HDPE OR DUCTILE IRON. CATHODIC PROTECTION REQUIRED ON FERROUS COMPONENTS PER STD. PLAN 534
7. ALL CULINARY WATER MAINS AND LATERALS SHALL BE INSTALLED ABOVE SEWER LINES UNLESS APPROVED BY PARK CITY AND UTAH DIVISION OF DRINKING WATER.

 PARK CITY MUNICIPAL CORPORATION WATER	DATE	WATER MAIN LOOP	STD. PLAN
	03/2024		544-C
	REV.		
	2		

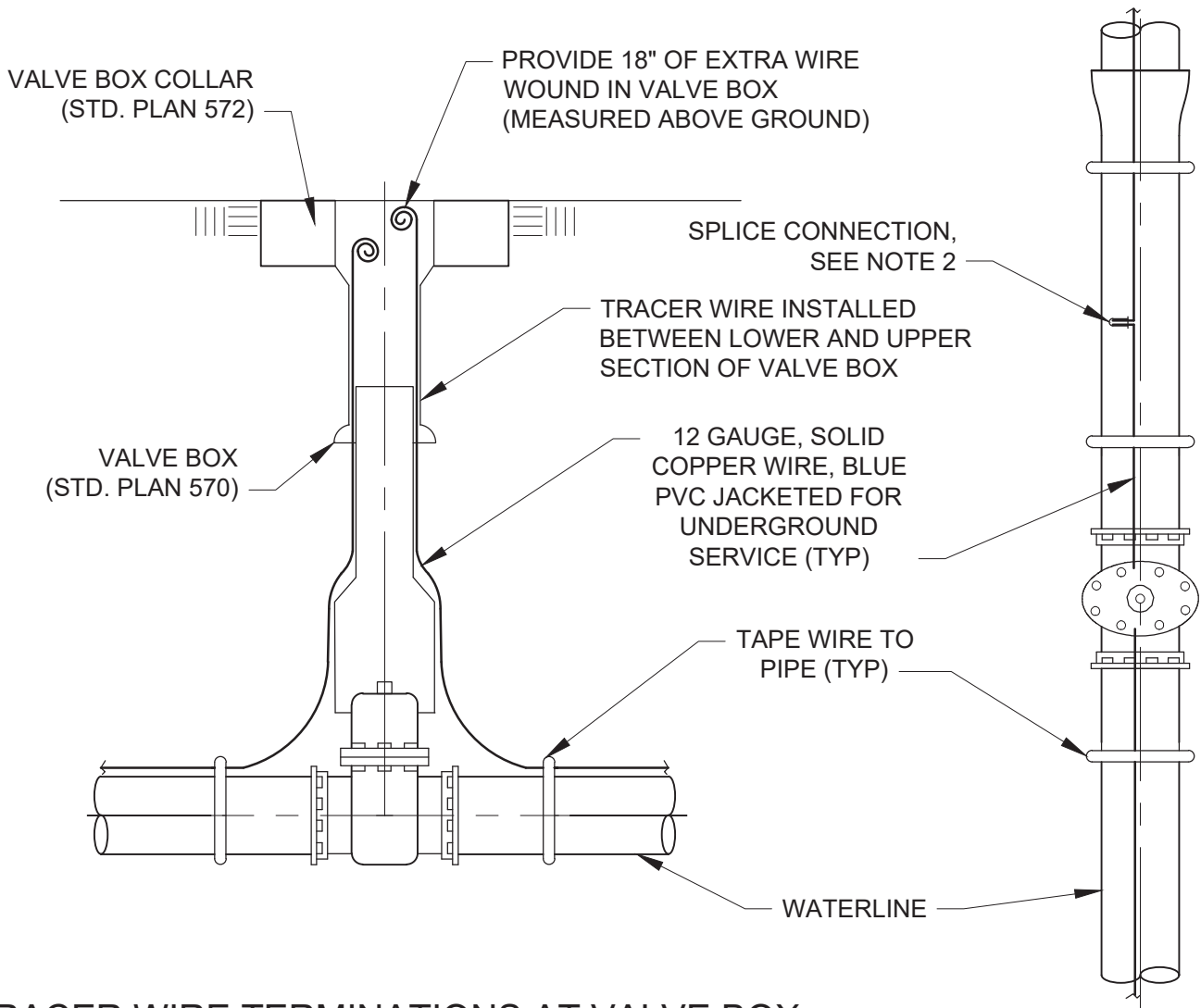

TRACER WIRE TERMINATIONS AT VALVE BOX

NOTES:

1. INSTALL TRACER WIRE ON ALL CONSTRUCTED (METALLIC AND NON-METALLIC) PIPE.
2. ALL SPLICES SHALL BE SILICONE FILLED WIRE CONNECTORS.
3. PROVIDE TRACER WIRE CONNECTIONS AT ALL VALVE BOXES AND PER STD. PLAN 545-B TO MAINTAIN A MAXIMUM DISTANCE BETWEEN CONNECTIONS OF NO GREATER THAN 500 FEET.
4. AT VAULT AND MANHOLE LOCATIONS COIL WIRE INSIDE.

 PARK CITY MUNICIPAL CORPORATION WATER	DATE	TRACER WIRE VALVE BOX TERMINATIONS	STD. PLAN
	03/2023		545-A
	REV.		
	2		

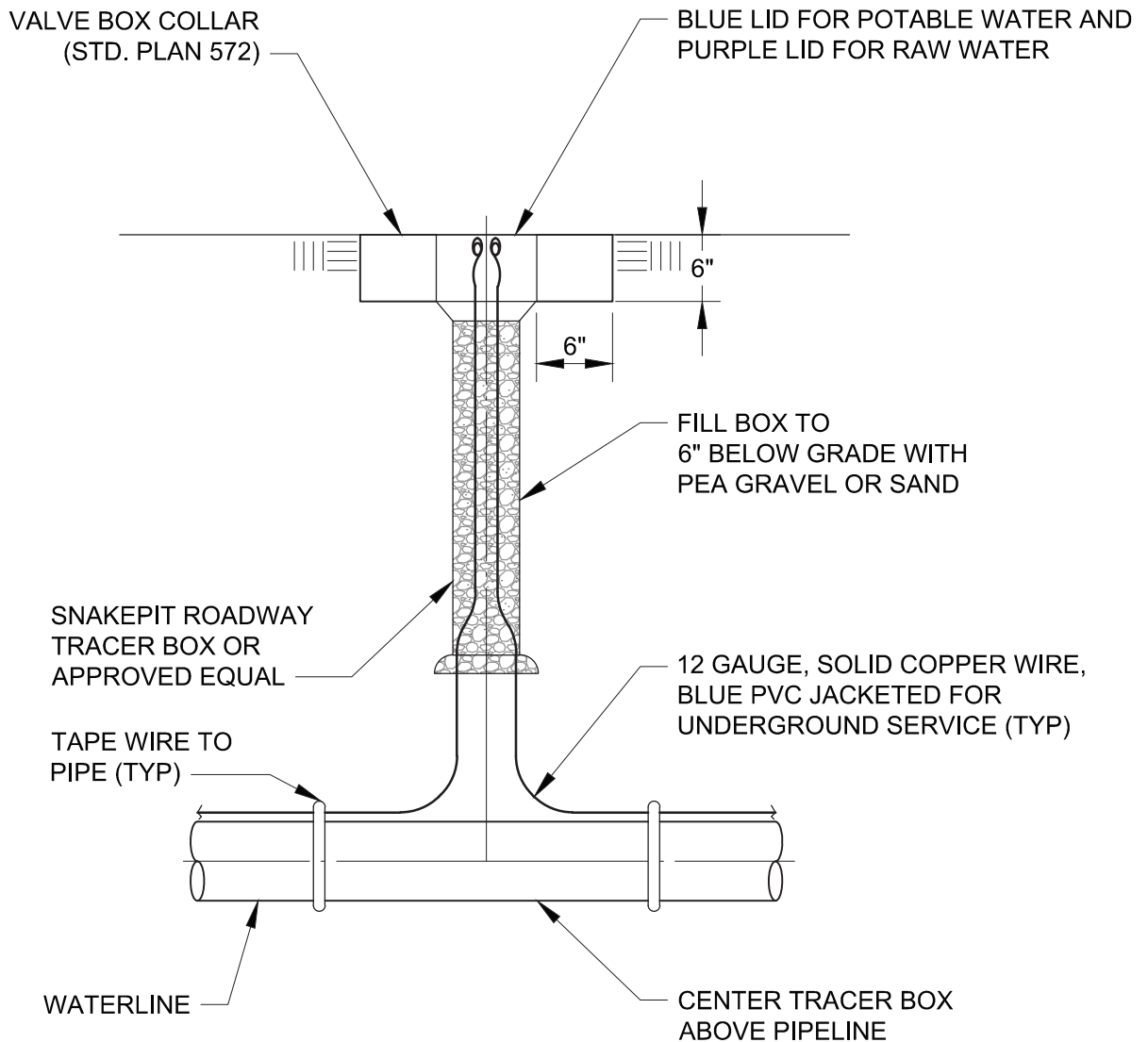

NOTES:

1. INSTALL LOCATOR WIRE ON ALL CONSTRUCTED (METALLIC AND NON-METALLIC) PIPE.
2. ALL SPLICES SHALL BE WITH SILICONE FILLED WIRE CONNECTORS.
3. PROVIDE LOCATOR WIRE CONNECTIONS PER THIS DETAIL AS REQUIRED TO MAINTAIN A MAXIMUM DISTANCE BETWEEN CONNECTIONS OF NO GREATER THAN 500 FEET. CONTRACTOR SHALL COORDINATE EACH LOCATION WITH OWNER.
4. LOCATOR WIRE AND WARNING TAPE NOT REQUIRED WHERE DIRECTIONAL DRILLING WILL TAKE PLACE.
5. AT VAULT LOCATIONS COIL WIRE INSIDE OF VAULT.

 PARK CITY MUNICIPAL CORPORATION WATER	DATE	TRACER WIRE ACCESS BOX TERMINATIONS	STD. PLAN
	3/2014		545-B
	REV.		
	0		

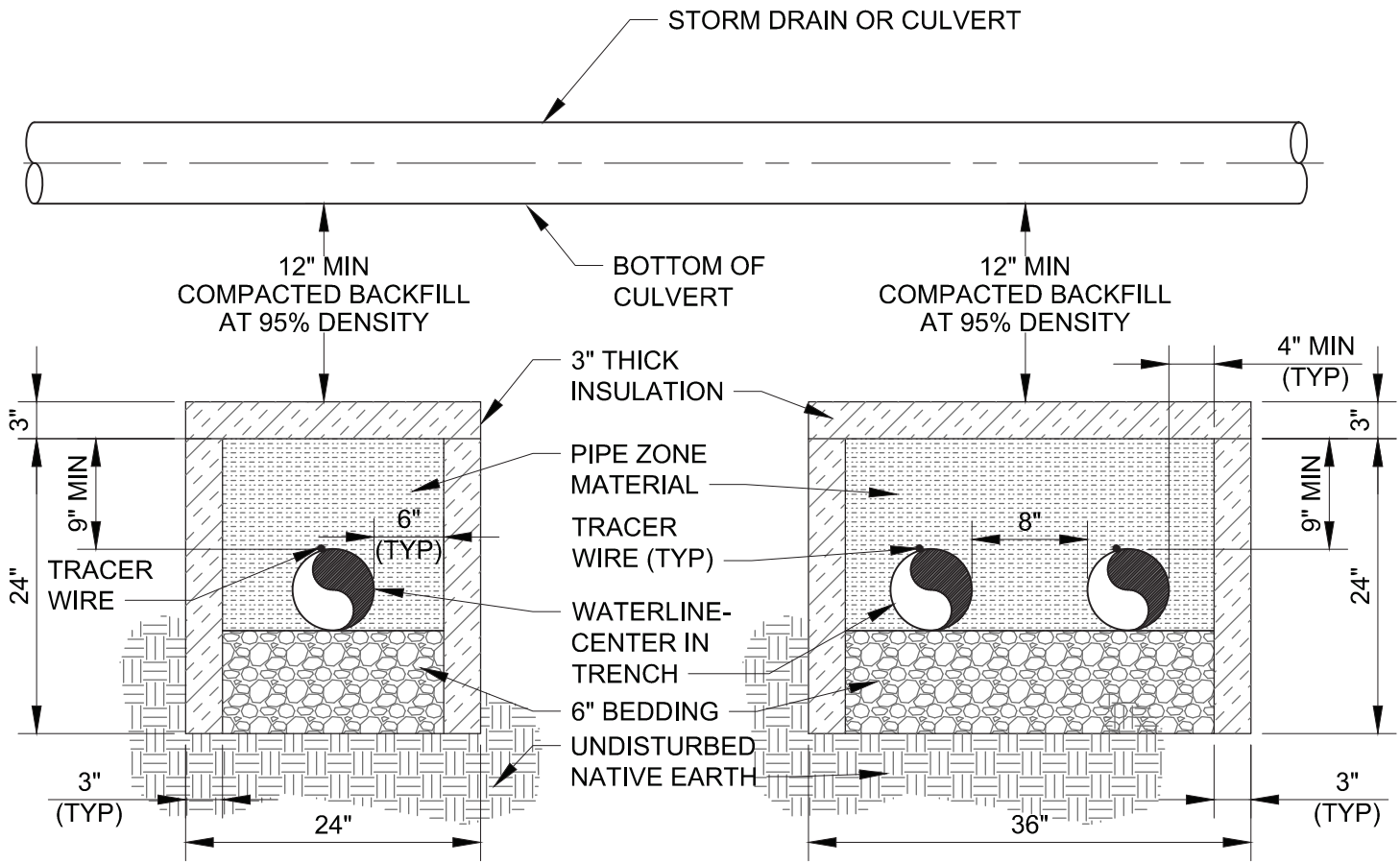

ONE LINE IN TRENCH

TWO LINES IN TRENCH

NOTES:

1. WHERE WATERLINES INTERSECT STORM DRAINS OR CULVERTS, INSTALL WATERLINE WITH FROST SHIELD. EXTEND FROST SHIELD A MINIMUM OF 3- FEET ON BOTH SIDES STORM DRAIN OR CULVERT.
2. INSULATION SHALL BE 3-INCH THICK INSULATION BOARD (DOW STYROFOAM HIGHLOAD - 60 INSULATION OR APPROVED EQUAL).
3. ALL BACKFILL MATERIAL, INCLUDING SPECIAL BEDDING AND PIPE ZONE MATERIAL, SHALL BE COMPACTED TO AT LEAST 95% DENSITY TO PROVIDE AN ADEQUATE FOUNDATION FOR THE CULVERT AND ROADWAY.
4. INSTALL TRACER WIRES AS REQUIRED (STD. PLAN 540, 541 AND 545)

 PARK CITY MUNICIPAL CORPORATION WATER	DATE	PIPE INSULATION AT STORM DRAIN CROSSINGS	STD. PLAN
	3/2014		546
	REV.		
	0		

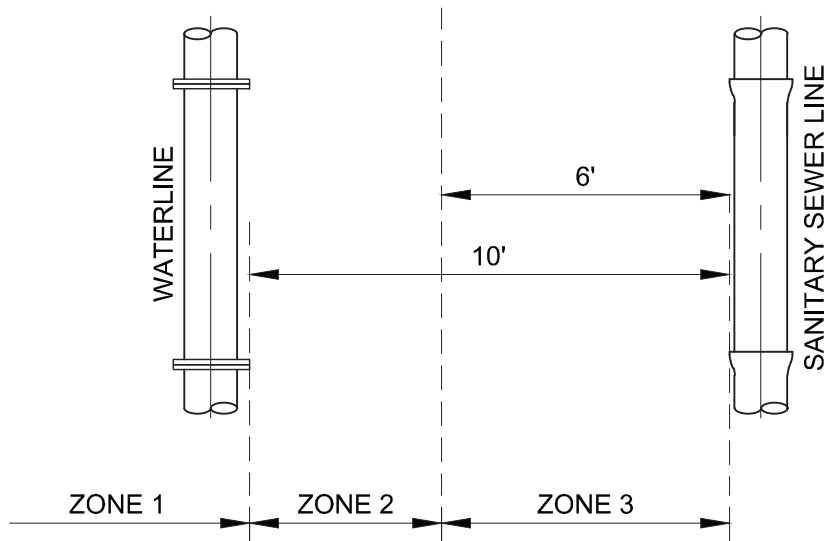

HORIZONTAL SEPARATION REQUIREMENTS

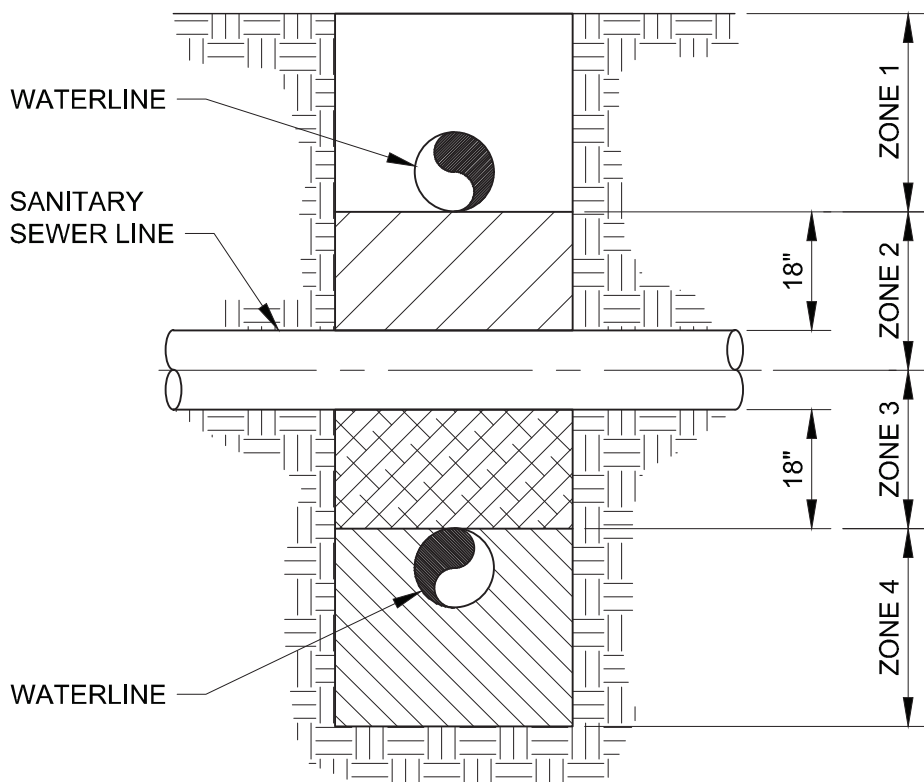

VERTICAL SEPARATION REQUIREMENTS

NOTES:

1. SEE STD. PLAN 547-B FOR HORIZONTAL AND VERTICAL SEPARATION REQUIREMENT NOTES.
2. ALL CULINARY WATER MAINS AND LATERALS SHALL BE INSTALLED ABOVE SEWER LINES UNLESS APPROVED BY PARK CITY AND UTAH DIVISION OF DRINKING WATER.

 PARK CITY MUNICIPAL CORPORATION WATER	DATE	WATER - SANITARY SEWER SEPARATION	STD. PLAN
	6/2019		547-A
	REV.		
	1		

HORIZONTAL SEPARATION NOTES:

1. ZONE 1: WATER LINE AND SEWER LINE SEPARATED 10 FEET OR GREATER – NO SPECIAL REQUIREMENTS
- ZONE 2: WHERE LOCAL CONDITIONS AND SITE SPECIFIC CONDITIONS PRECLUDE ZONE 1 SEPARATION – SPECIAL REQUIREMENTS APPLY:
 - A) APPROVAL BY DIVISION OF ENVIRONMENTAL QUALITY, DIVISION OF DRINKING WATER AND,
 - B) SEWER PIPES IN GOOD CONDITION AND,
 - C) NO HIGH GROUNDWATER AND,
 - D) WATER LINE SEPARATED BY AT LEAST 6 FEET AT OUTSIDE PIPE WALLS AND,
 - E) BOTTOM OF WATER LINE IS AT LEAST 18 INCHES ABOVE TOP OF SEWER LINE AND,
 - F) WATER LINE CONSTRUCTED WITH MECHANICAL, RESTRAINED JOINT PIPE
- ZONE 3: WATER LINE AND SEWER LINE SEPARATED LESS THAN 6 FEET – NOT ALLOWED WITHOUT APPROVAL OF PUBLIC UTILITIES ENGINEER AND APPROVED EXCEPTION TO RULE R309-550-7 BY UTAH DIVISION OF ENVIRONMENTAL QUALITY, DIVISION OF DRINKING WATER. ADDITIONAL MITIGATION MEASURES TO PROTECT PUBLIC HEALTH MAY BE REQUIRED.
2. ADDITIONAL WATER-SEWER SEPARATION AND/OR SPECIAL PIPE MATERIALS MAY BE REQUIRED IN AREAS OF HIGH GROUNDWATER, SOILS CONDITIONS, OR SPECIAL SEWER LINE CONTENTS
3. SERVICE LINE TAPS NOT ALLOWED IN ZONE 2
4. SERVICE LINE TAPS WITHIN ZONE 3 ALLOWED ONLY BY SITE SPECIFIC APPROVAL BY DIVISION OF ENVIRONMENTAL QUALITY, DIVISION OF DRINKING WATER
5. CONSULT SNYDERVILLE BASIN WATER RECLAMATION DISTRICT FOR ADDITIONAL SANITARY SEWER RELATED REQUIREMENTS AND SEWER LINE MODIFICATIONS

VERTICAL SEPARATION NOTES:

1. ZONE 1: WATER LINE ABOVE SEWER LINE AND SEPARATED 18 INCHES OR GREATER – NO SPECIAL REQUIREMENTS
- ZONE 2: WATER LINE ABOVE SEWER LINE SEPARATED LESS THAT 18 INCHES – NOT ALLOWED WITHOUT APPROVAL OF PUBLIC UTILITIES ENGINEER AND APPROVED EXCEPTION TO RULE R309-550-7 BY UTAH DIVISION OF ENVIRONMENTAL QUALITY, DIVISION OF DRINKING WATER. ADDITIONAL MITIGATION MEASURES TO PROTECT PUBLIC HEALTH MAY BE REQUIRED SUCH AS: INSTALL CONTROLLED LOW-STRENGTH MATERIAL (CLSM), “FLOWABLE FILL”, 150 PSI MAXIMUM MIX DESIGN WITHIN WATER PIPE ZONE AND TO 18” ABOVE THE SEWER LINE.
- ZONE 3: WATER LINE BELOW SEWER LINE SEPARATED LESS THAN 18 INCHES – NOT ALLOWED WITHOUT APPROVAL OF PUBLIC UTILITIES ENGINEER AND APPROVED EXCEPTION TO RULE R309-550-7 BY UTAH DIVISION OF ENVIRONMENTAL QUALITY, DIVISION OF DRINKING WATER. ADDITIONAL MITIGATION MEASURES TO PROTECT PUBLIC HEALTH MAY BE REQUIRED SUCH AS: INSTALL CONTROLLED LOW-STRENGTH MATERIAL (CLSM), “FLOWABLE FILL”, 150 PSI MAXIMUM MIX DESIGN WITHIN WATER PIPE ZONE AND TO 18” ABOVE THE SEWER LINE.
- ZONE 4: WATER LINE BELOW SEWER LINE SEPARATED GREATER THAN 18 INCHES - NOT ALLOWED WITHOUT APPROVAL OF PUBLIC UTILITIES ENGINEER AND APPROVED EXCEPTION TO RULE R309-550-7 BY UTAH DIVISION OF ENVIRONMENTAL QUALITY, DIVISION OF DRINKING WATER. ADDITIONAL MITIGATION MEASURES TO PROTECT PUBLIC HEALTH MAY BE REQUIRED SUCH AS: CENTER ONE FULL UN CUT LENGTH OF WATER PIPE OVER THE CROSSING AND PROVIDE MECHANICAL RESTRAINED PIPE JOINTS UNTIL THE WATER PIPE EXTENDS TO A DISTANCE OF 10 FEET PERPENDICULAR TO EACH SIDE OF THE SEWER LINE. INSTALL CONTROLLED LOW-STRENGTH MATERIAL (CLSM), “FLOWABLE FILL”, 150 PSI MAXIMUM MIX DESIGN WITHIN WATER PIPE ZONE AND TO 18” ABOVE THE SEWER LINE.
2. SERVICE LINE TAPS NOT ALLOWED IN ZONES 2 AND 3.
3. MAINTAIN 10 FEET HORIZONTAL SEPARATION AND 18 INCHES VERTICAL SEPARATION ABOVE SANITARY SEWER FORCE MAINS
4. CONSULT SNYDERVILLE BASIN WATER RECLAMATION DISTRICT FOR ADDITIONAL SANITARY SEWER RELATED REQUIREMENTS AND SEWER LINE MODIFICATIONS
5. ALL CULINARY WATER MAINS AND LATERALS SHALL BE INSTALLED ABOVE SEWER LINES UNLESS APPROVED BY THE PUBLIC UTILITIES ENGINEER AND UTAH DIVISION OF DRINKING WATER.

 PARK CITY MUNICIPAL CORPORATION WATER	DATE	WATER – SANITARY SEWER SEPARATION NOTES	STD. PLAN
	5/2025		547-B
	REV.		
	2		

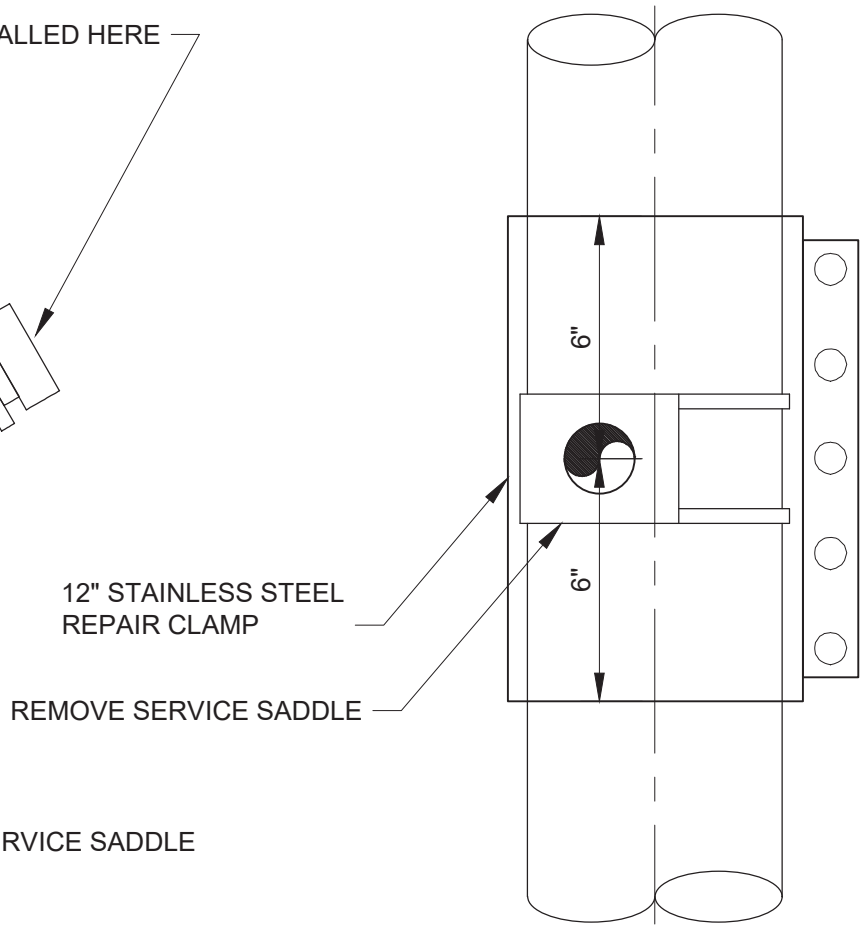
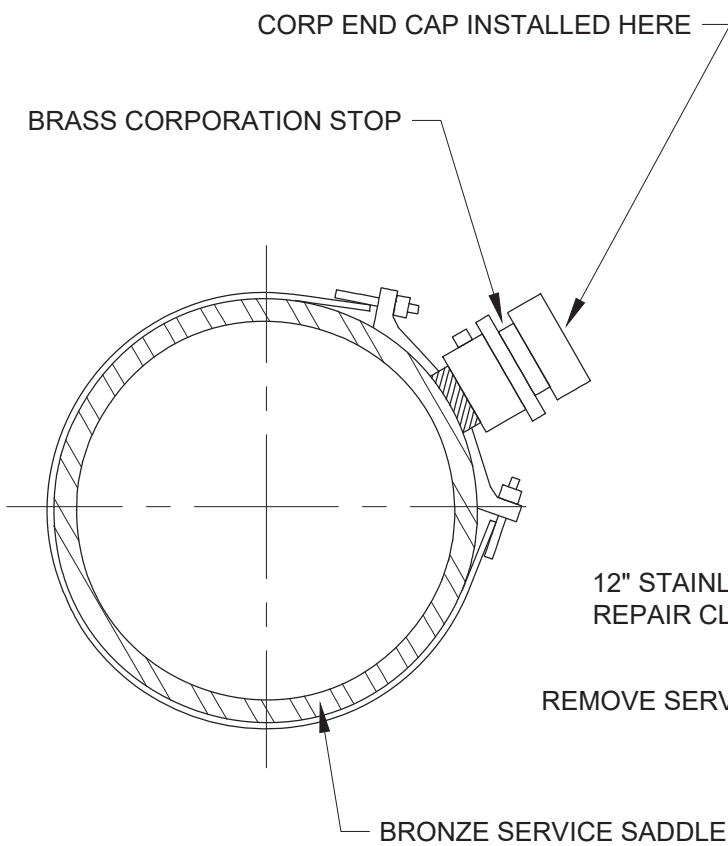

SERVICEABLE SADDLE

NONSERVICEABLE SADDLE

NOTES:

1. IF BOTH THE BRONZE SADDLE AND CORPORATION STOP ARE IN GOOD CONDITION:
 - A. THE CORPORATION IS TO BE SHUT OFF, DISCONNECTED FROM THE SERVICE LATERAL, AND INSPECTED FOR LEAKS
 - B. IF THE BRONZE SADDLE AND CORPORATION STOP ARE IN GOOD CONDITION AND DO NOT LEAK A BRASS END CAP IS TO BE INSTALLED ON THE CORPORATION STOP ($\frac{3}{4}$ " FORD CAP-24-3-NL, 1" FORD CAP-2-4-NL, OR FORD CAP 4-4-NL, 1 $\frac{1}{2}$ "-FORD CAP-2-6-NL OR FORD CAP-4-6-Q-NL) OR APPROVED EQUIVALENTS
 - C. APPLY WAX TAPE COATING SYSTEM TO SERVICE SADDLE BOLTS AND CORPORATION STOP (STD. PLAN 534.2)

2. A WATER SHUTDOWN AND INSTALLATION OF A STAINLESS-STEEL REPAIR CLAMP WILL BE MANDATORY IF, BUT NOT LIMITED TO:
 - A. THE SADDLE IS NOT BRONZE, IS IN POOR CONDITION, OR LEAKS
 - B. THE CORPORATION STOP LEAKS OR IS TAPPED DIRECTLY INTO THE WATER MAIN
 - C. THE SURFACE AREA OF THE WATER MAIN SURROUNDING THE TAP IS IN POOR CONDITION
 - D. APPLY WAX TAPE COATING SYSTEM TO THE ENTIRE STAINLESS STEEL REPAIR CLAMP, THE BAND, BOLTS, AND NUTS (STD. PLAN 534.2)

 PARK CITY MUNICIPAL CORPORATION WATER	DATE	$\frac{3}{4}$" TO 2" SERVICE LINE ABANDONMENT	STD. PLAN
	03/2024		548
	REV.		
	0		

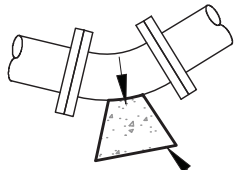

BEARING AREA
UNDISTURBED SOIL (TYP)

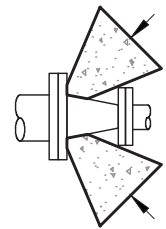
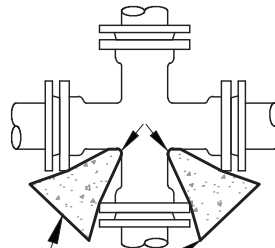
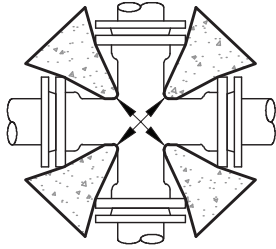
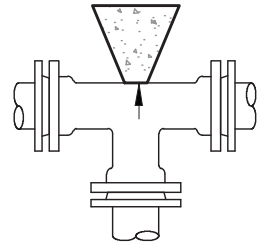
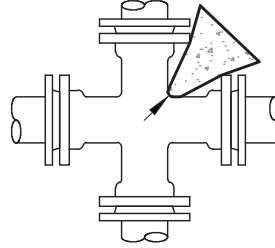
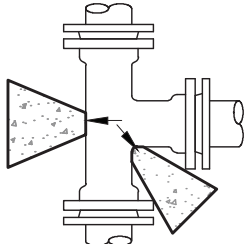
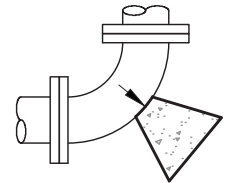
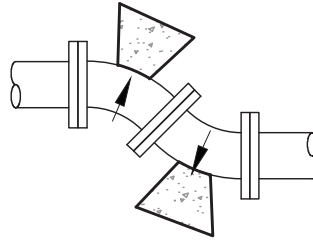

**MINIMUM BEARING AREA
IN SQ. FT.**

SIZE OF PIPE	TEES, VALVES, DEAD ENDS	90° BENDS	45° BENDS	22 1/2° BENDS	11 1/4° BENDS
4"	3.5	5	3	1.5	1
6"	7	10	5.5	3	1.5
8"	12.5	17	9.5	5	2.5
10"	18.5	26	14	7.5	3.8
12"	26	37	20	10	5
14"	35	49	26.5	13.5	7
16"	45	63	34	17.5	9

THE AREA OF BEARING PER
THRUST BLOCK TO EQUAL 1/2 THE
AREA SPECIFIED FOR THE
LARGEST PIPE OR FITTING SIZE

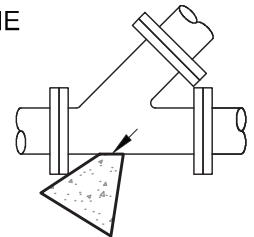

NOTE:

1. RESTRAINT SIZING IS BASED UPON A MAXIMUM OPERATING PRESSURE OF 150 PSI AND A TEST PRESSURE OF 250 PSI, AND A MINIMUM SOIL BEARING STRENGTH OF 2,000 PSF. OPERATING PRESSURES IN EXCESS OF 150 PSI OR SOILS WITH LESS THAN 2,000 POUND BEARING STRENGTH WILL REQUIRE SPECIAL DESIGN.
2. PIPE SIZE EXCEEDING 16" REQUIRES SPECIAL DESIGN.
3. SIDE WALLS OF THRUST BLOCK SHALL BE FORMED WITH VERTICAL SIDES.
4. DO NOT ENCASE ADJACENT FITTINGS AND BOLTS.
5. DO NOT THRUST AGAINST ADJACENT PIPES.
6. PLACE PE WRAP PRIOR TO INSTALLING BLOCKING.



PARK CITY MUNICIPAL CORPORATION
WATER

DATE

3/2014

REV.

0

**DIRECT BEARING
THRUST BLOCK**

STD. PLAN

561

TABLE OF DIMENSIONS					
SIZE OF PIPE (NOMINAL DIAMETER)	VERTICAL BEND IN DEGREES	CONCRETE BLOCKING IN CUBIC FEET	'S'	'd'	'L'
			SIDE OF CUBE - FEET	DIAMETER OF SHANK OR REBAR RODS - INCH	DEPTH OF ROD IN CONCRETE - FEET
4"	11 1/4	9.5	2.2	5/8"	1.5
	22 1/2	19.0	2.7	5/8"	2.0
6"	11 1/4	20	2.7	5/8"	2.0
	22 1/2	40	3.4	5/8"	2.0
8"	11 1/4	34	3.3	5/8"	2.0
	22 1/2	68	4.1	5/8"	2.0
10"	11 1/4	51	3.8	5/8"	2.0
	22 1/2	102	4.7	3/4"	3.0
12"	11 1/4	72	4.2	5/8"	2.0
	22 1/2	143	5.3	3/4"	3.0
14"	11 1/4	97	4.6	7/8"	3.0
	22 1/2	193	5.8	7/8"	3.0
16"	11 1/4	125	5.0	7/8"	3.0
	22 1/2	249	6.3	7/8"	4.0

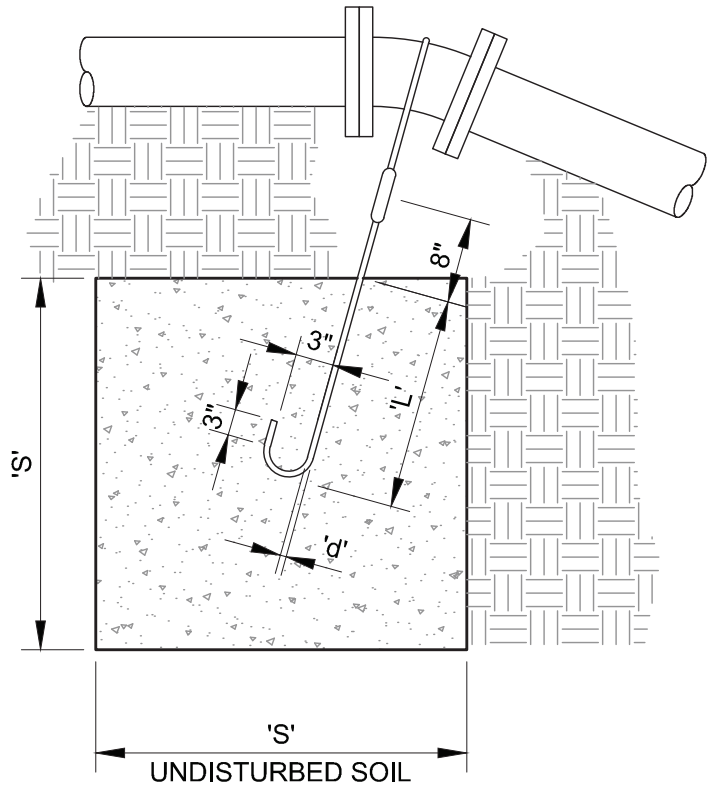

TYPE A RESTRAINT

FOR 11 1/4° - 22 1/2° VERTICAL BENDS

NOTE:

1. RESTRAINT SIZING IS BASED UPON A MAXIMUM OPERATING PRESSURE OF 150 PSI AND A TEST PRESSURE OF 250 PSI, AND A MINIMUM SOIL BEARING STRENGTH OF 2,000 PSF. OPERATING PRESSURES IN EXCESS OF 150 PSI OR SOILS WITH LESS THAN 2,000 POUND BEARING STRENGTH WILL REQUIRE SPECIAL DESIGN.
2. PIPE SIZE EXCEEDING 16" REQUIRES SPECIAL DESIGN.
3. SIDE WALLS OF THRUST BLOCK SHALL BE FORMED WITH VERTICAL SIDES.
4. DO NOT ENCASE ADJACENT FITTINGS AND BOLTS.
5. DO NOT THRUST AGAINST ADJACENT PIPES.
6. APPLY WAX TAP COATING SYSTEM TO EXPOSED SHANK AND REBAR RODS, AWWA C217. SYSTEM TO INCLUDE FILLER MATERIAL, TAPE COATING, AND PROTECTIVE OUTER WRAP. DENSO N.A., TRENTON, OR APPROVED EQUAL.
7. SHANK AND REBAR MATERIALS SHALL BE EPOXY COATED AT LEAST 15 MILS THICK.
8. REINFORCEMENT SHALL BE DEFORMED STEEL, ASTM A 615. MINIMUM STRESS YIELD STRENGTH OF STEEL TIE-DOWN BARS IS 70,000 KSI.

 PARK CITY MUNICIPAL CORPORATION WATER	DATE	TIE-DOWN THRUST RESTRAINTS	STD. PLAN
	3/2014		562-A
	REV.		
	0		

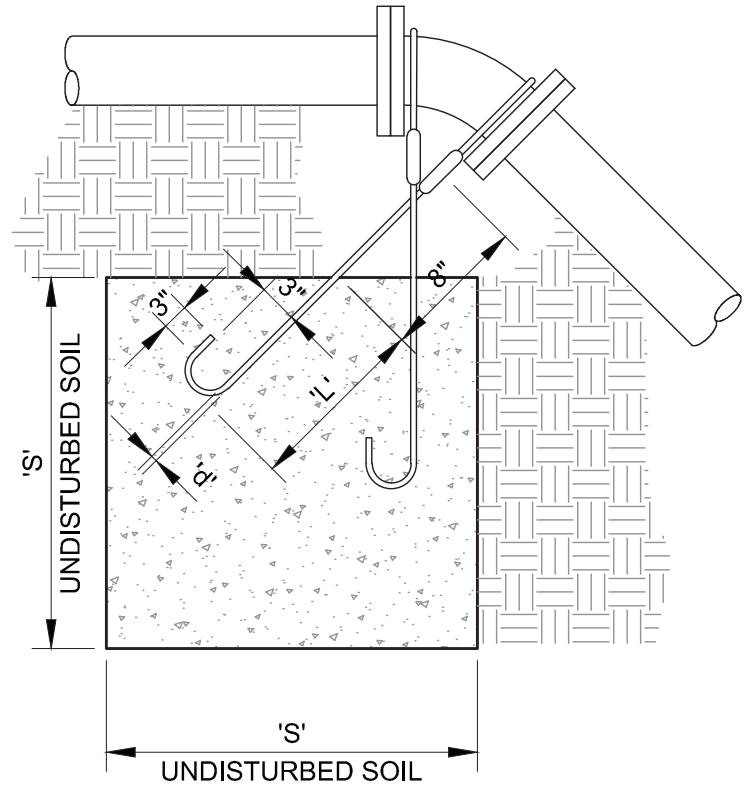

TYPE B RESTRAINT
FOR 45° VERTICAL BENDS

NOTE:

1. RESTRAINT SIZING IS BASED UPON A MAXIMUM OPERATING PRESSURE OF 150 PSI AND A TEST PRESSURE OF 250 PSI, AND A MINIMUM SOIL BEARING STRENGTH OF 2,000 PSF. OPERATING PRESSURES IN EXCESS OF 150 PSI OR SOILS WITH LESS THAN 2,000 POUND BEARING STRENGTH WILL REQUIRE SPECIAL DESIGN.
2. PIPE SIZE EXCEEDING 16" REQUIRES SPECIAL DESIGN.
3. SIDE WALLS OF THRUST BLOCK SHALL BE FORMED WITH VERTICAL SIDES.
4. DO NOT ENCASE ADJACENT FITTINGS AND BOLTS.
5. DO NOT THRUST AGAINST ADJACENT PIPES.
6. APPLY WAX TAP COATING SYSTEM TO EXPOSED SHANK AND REBAR RODS, AWWA C217. SYSTEM TO INCLUDE FILLER MATERIAL, TAPE COATING, AND PROTECTIVE OUTER WRAP. DENSO N.A., TRENTON, OR APPROVED EQUAL.
7. SHANK AND REBAR MATERIALS SHALL BE EPOXY COATED AT LEAST 15 MILS THICK.
8. REINFORCEMENT SHALL BE DEFORMED STEEL, ASTM A 615. MINIMUM STRESS YIELD STRENGTH OF STEEL TIE-DOWN BARS IS 70,000 KSI.

TABLE OF DIMENSIONS					
SIZE OF PIPE (NOMINAL DIAMETER)	VERTICAL BEND IN DEGREES	CONCRETE BLOCKING IN CUBIC YARDS	'S' SIDE OF CUBE - FEET	'd' DIAMETER OF SHANK OR REBAR RODS - INCH	'L' DEPTH OF ROD IN CONCRETE - FEET
4"	45	1.4	3.4	5/8"	2.0
				5/8"	
6"	45	2.8	4.3	5/8"	2.5
				5/8"	
8"	45	4.9	5.1	5/8"	3.0
				5/8"	
10"	45	7.3	5.9	5/8"	4.0
				5/8"	
12"	45	10.4	6.8	3/4"	4.0
				3/4"	
14"	45	14.0	7.3	3/4"	4.0
				3/4"	
16"	45	18.1	7.9	3/4"	4.0
				3/4"	

 PARK CITY MUNICIPAL CORPORATION WATER	DATE	<h2 style="margin: 0;">TIE-DOWN THRUST RESTRAINTS</h2>	STD. PLAN
	3/2014		<h1 style="margin: 0;">562-B</h1>
	REV.		
	0		

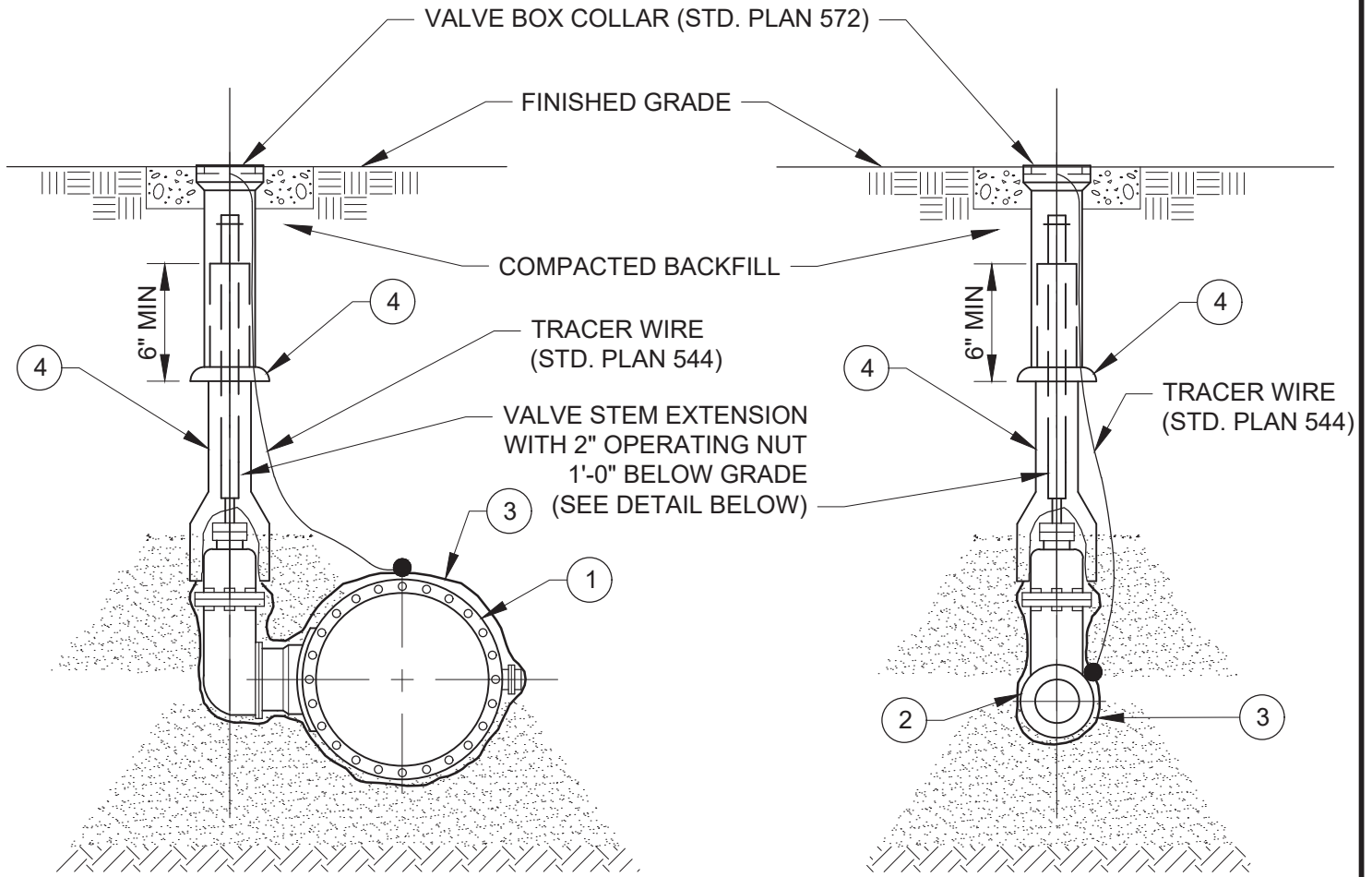

BUTTERFLY VALVE

GATE VALVE

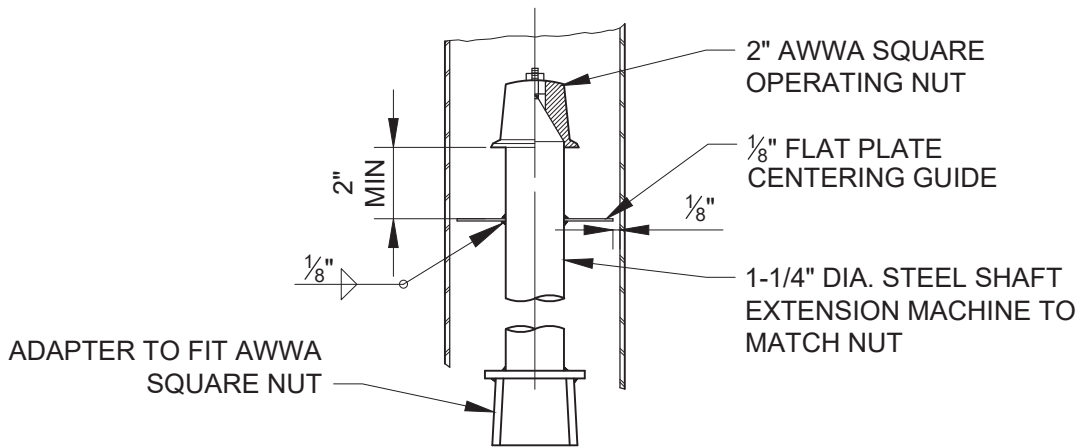

VALVE STEM EXTENSION

NOTES:

1. VALVE STEM EXTENSIONS ARE ONLY TO BE USED WHEN THE VALVE IS GREATER THAN 8' DEEP
2. REFER TO STD. PLAN 570 S FOR LEGEND ITEMS, APPROVED PARTS LIST, AND DETAIL NOTES.

 PARK CITY MUNICIPAL CORPORATION WATER	DATE	BURIED VALVE AND VALVE BOX	STD. PLAN
	03/2024		570
	REV.		
1			

LEGEND AND APPROVED PARTS LIST

ITEM	DESCRIPTION	ACCEPTABLE MANUFACTURER	MODELS
①	BUTTERFLY VALVE, NRS, AWWA C504 CLASS 250B, 250 PSI, SST BONNET BOLTS, FLANGED END CONNECTIONS	MUELLER	LINESEAL XP11, 5227 SERIES OR APPROVED EQUAL
②	GATE VALVE, NRS, AWWA C509, 250 PSI, SST BONNET BOLTS, END CONNECTIONS PER FOLLOWING: ON TEES: FLG x FLG IN-LINE VALVES: MJ x MJ OTHERS: MJ x MJ, OR PER DESIGN	MUELLER	SERIES 2360 OR APPROVED EQUAL
③	POLYETHYLENE ENCASEMENT, HIGH DENSITY CROSS LAMINATED (HDCL) POLYETHYLENE FILM, AWWA C105 & AWWA C703E METHOD C	CHRISTY'S OR APPROVED EQUAL	AWWA C703E METHOD C (4 MIL)
④	VALVE BOX, CAST IRON, TWO PIECE, SLIP TYPE WITH CAST IRON DROP-IN COVER MARKED AS FOLLOWS: ISOLATION VALVE: "WATER" BUTTERFLY VALVE: "BFV" IRRIGATION: "IRRIG" FIRE LINE VALVE: "FIRE" VALVE BOX RISER: LIMIT ONE PER VALVE BOX	D&L SUPPLY OR APPV'D EQUAL	BOX AND LID: M-8042 RISER: M-8049 THRU M-8055 EXTENSION: M-8070

DETAIL NOTES

1. VALVES TO BE RATED FOR WORKING AND TEST PRESSURE OF WATER MAIN
2. PROVIDE FUSION BONDED EPOXY COATING ON GATE VALVE AND BUTTERFLY VALVE INTERIOR AND EXTERIOR
3. PROVIDE 316 SST BOLTS AND NUTS WITH ANTI-SEIZE LUBRICANT ON FLANGED CONNECTIONS
4. DO NOT LOCATE VALVE AND VALVE BOX WITHIN CURB OR GUTTER
5. CENTER VALVE BOX ON VALVE OPERATING NUT
6. SET VALVE BOX PLUMB WITHOUT DEFLECTIONS IN VALVE BOX JOINTS
7. PROVIDE ADDITIONAL SLIP BASE FOR VALVE BOX ON 7' BURY WATER MAIN
8. APPLY WAX TAPE COATING SYSTEM TO VALVE BONNET BOLTS AND ALL OTHER BURIED BOLTS AND NUTS, AWWA C217. SYSTEM TO INCLUDE FILLER MATERIAL, TAPE COATING, AND PROTECTIVE OUTERWRAP. DENSO NORTH AMERICA, TRENTON, OR APPROVED EQUAL (STD. PLAN 534)

 PARK CITY MUNICIPAL CORPORATION WATER	DATE	<h2 style="margin: 0;">BURIED VALVE AND VALVE BOX</h2>	STD. PLAN
	02/2024		570 S
	REV.		
	1		

COLD JOINT

#4 HOOP STEEL
6" RADIUS

6"



ASPHALT PAVEMENT
(THICKNESS VARIES)

CONCRETE TO BE
SET $\frac{1}{4}$ " MIN. TO $\frac{1}{2}$ " MAX.
BELOW PAVEMENT
LIP ALL AROUND

6" MIN

BASE COURSE

SLIP SLEEVE
(STD. PLAN 570)

SLIP SLEEVE
(STD. PLAN 570)

ASPHALT PAVEMENT

CONCRETE PAVEMENT

#4 HOOP STEEL
(6" RADIUS)
COLD JOINT

6"

CONCRETE COLLAR TO BE
SET UNLESS OTHERWISE
DIRECTED BY THE PARK CITY
PUBLIC UTILITY ENGINEER.
SET TO GRADE AS DIRECTED
BY PARK CITY PUBLIC UTILITY
ENGINEER.

6" MIN

SLIP SLEEVE
(STD. PLAN 570)

LANDSCAPED AREA



PARK CITY MUNICIPAL CORPORATION
WATER

DATE

5/2025

REV.

2

VALVE BOX COLLAR

STD. PLAN

572

GENERAL NOTES

1. ALL WORK SHALL CONFORM TO PARK CITY DESIGN STANDARDS, CONSTRUCTION SPECIFICATIONS, AND STANDARD DRAWINGS.
2. SUBMIT SHOP DRAWINGS TO DESIGN ENGINEER AND CITY ENGINEER FOR APPROVAL PRIOR TO CONSTRUCTION. INCLUDE MECHANICAL, STRUCTURAL, ELECTRICAL AND INSTRUMENT DRAWINGS IDENTIFYING CONDUIT, CONDUCTOR, CABLE, SIZE AND ROUTINGS FOR POWER, GROUNDING, INSTRUMENTATION, AND CONTROLS, OPENINGS, PIPE, VALVES, HATCH, AND ALL VAULT COMPONENTS.
3. VAULT BACKFILL: STRUCTURAL FILL MATERIAL COMPACTED TO 95% MINIMUM OF MODIFIED PROCTOR DENSITY.
4. DUCTILE IRON PIPE, FITTINGS, COUPLERS, FLANGES, ETC. SHALL BE IN ACCORDANCE WITH AWWA C153, C111, AND C110 AND RATED FOR A MINIMUM 250 PSI WORKING PRESSURE.
5. FLANGED JOINTS: 125 LB FLANGES, ANSI/AWWA C115/A21.15. "FULL FACE FLANGE-TYTE" GASKET OR "RING FLANGE-TYTE" GASKET (OR PRE-APPROVED EQUAL). GASKETS TO BE HIGH-PERFORMANCE TYPE, 1/8" THICK, AND HAVE AT LEAST (3) BULB TYPE RINGS MOLDED INTO BOTH GASKET FACES, ANSI/AWWA C110/A21.11.
6. FITTINGS: FULL BODY AWWA C110. NO COMPACT FITTINGS. DOMESTIC "MADE IN USA".
7. DUCTILE IRON PIPE AND FITTINGS: UNCOATED. PRIME AND PAINT WITH NSF APPROVED HIGH SOLIDS EPOXY PAINT, TNEMEC POTA-POX N140 OR PRE-APPROVED EQUAL. HIGH PRESSURE SIDE, LIGHT BLUE. LOW PRESSURE SIDE, OFF WHITE.
8. ALL VALVES INSIDE VAULT SHALL BE RATED FOR 250 PSI WORKING PRESSURE, OR HIGHER IF REQUIRED FOR PROJECT.
9. VAULT SHALL BE PRECAST CONCRETE. APPROVAL MUST BE GIVEN TO USE CAST IN PLACE CONCRETE. VAULT SHALL BE DESIGNED FOR HS-20 LOADING. THE LOCATION OF THE PRECAST JOINTS MUST BE APPROVED. SITE SPECIFIC APPROVAL REQUIRED.
10. SEAL ALL JOINTS WITH PREFORMED FLEXIBLE SEALANT CONFORMING TO ASTM C990, AND WRAP WITH EXTERNAL JOINT SEALANT MEETING ASTM C877. FILL JOINTS INSIDE VAULT WITH CAULK OR GROUT.
11. PROVIDE (2) 8 HR DAYS FOR TESTING, STARTUP, AND TRAINING FOR PRV VALVES WITH MANUFACTURER REPRESENTATIVE.
12. SEAL ALL VAULT PENETRATIONS WITH HYDROPHILIC NON-SHRINK GROUT.
13. 36" MINIMUM LANDSCAPE CLEARANCE AROUND HATCH REQUIRED.
14. 24" CLEAR, CONVENIENT AND UNINHIBITED ACCESS PATH REQUIRED TO HATCH.

 <p>PARK CITY 1884 PARK CITY MUNICIPAL CORPORATION WATER</p>	DATE	PRESSURE REDUCING VALVE VAULT	STD. PLAN
	10/2020		573-A
	REV.		
	1		

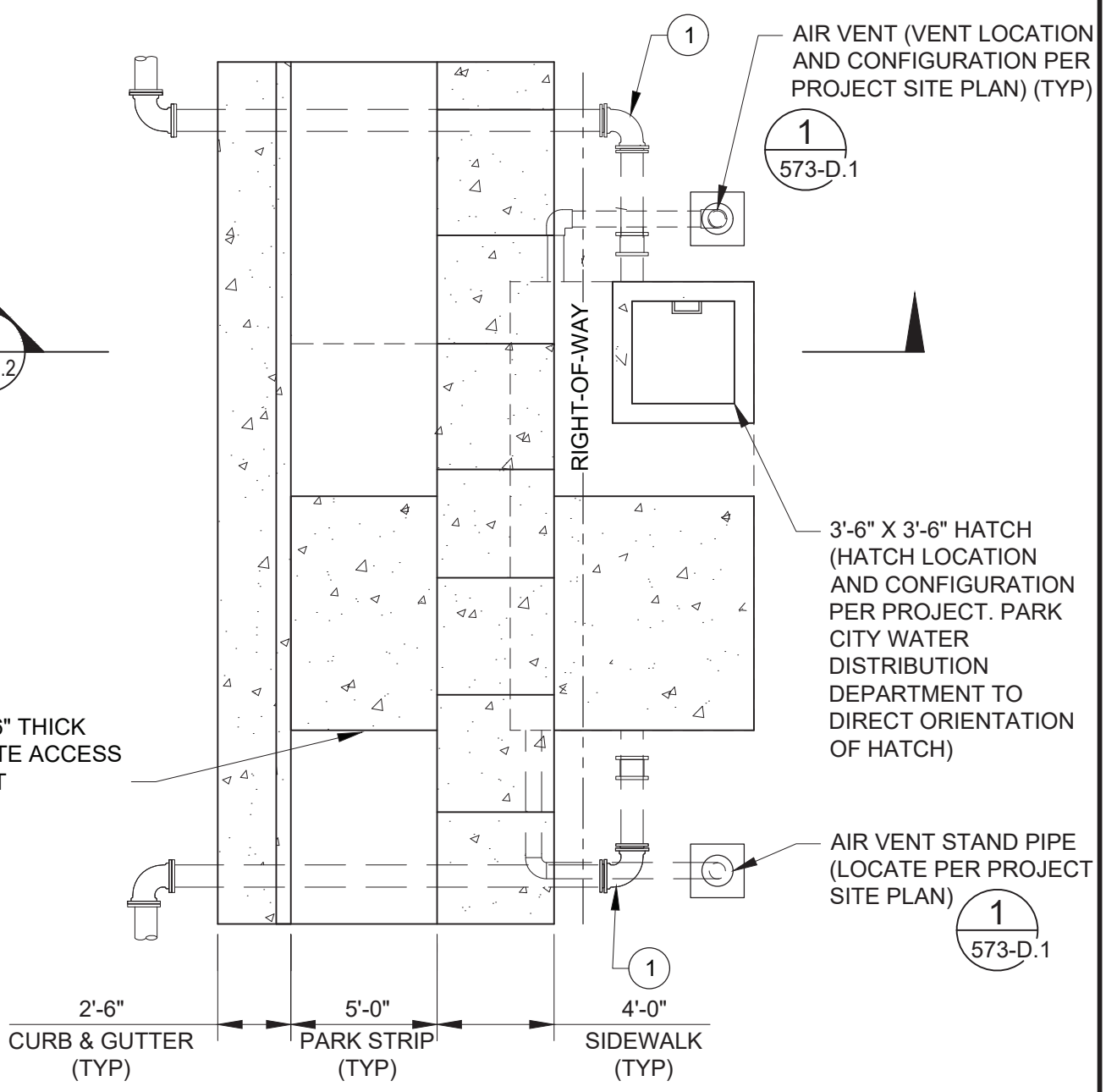

VAULT LOCATION PLAN

NTS

NOTES:

- 1. FOR GENERAL NOTES, SEE STD. PLAN 573-A, AND FOR (#) KEYED ITEMS, SEE STD. PLAN 573-C.3 AND C.4.
- 2. SITE SPECIFIC APPROVAL REQUIRED. NEW EASEMENTS WILL BE REQUIRED IF VAULT IS LOCATED OUTSIDE OF PROPERTY LINE.

 PARK CITY MUNICIPAL CORPORATION WATER	DATE	PRESSURE REDUCING VALVE VAULT	STD. PLAN
	03/2024		573-B.1
	REV.		
	1		

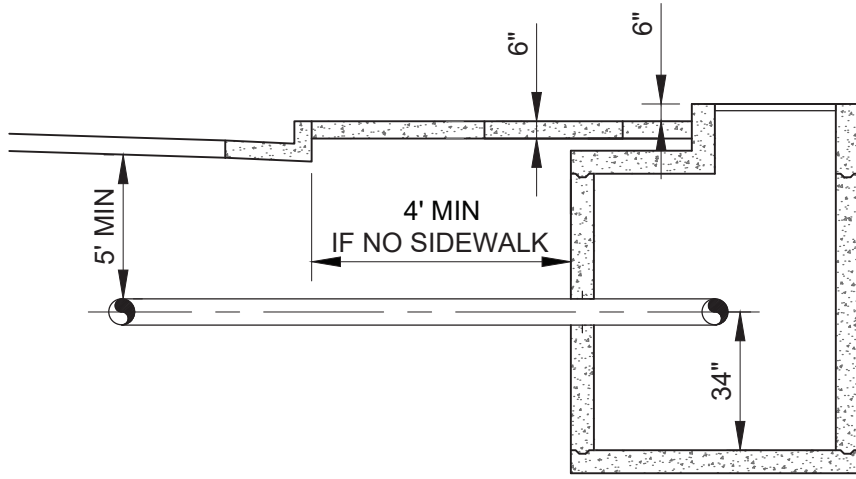

VAULT SECTION A
 NTS 573-B.1



PARK CITY MUNICIPAL CORPORATION
WATER

DATE

03/2024

REV.

1

**PRESSURE REDUCING
 VALVE VAULT**

STD. PLAN

573-B.2

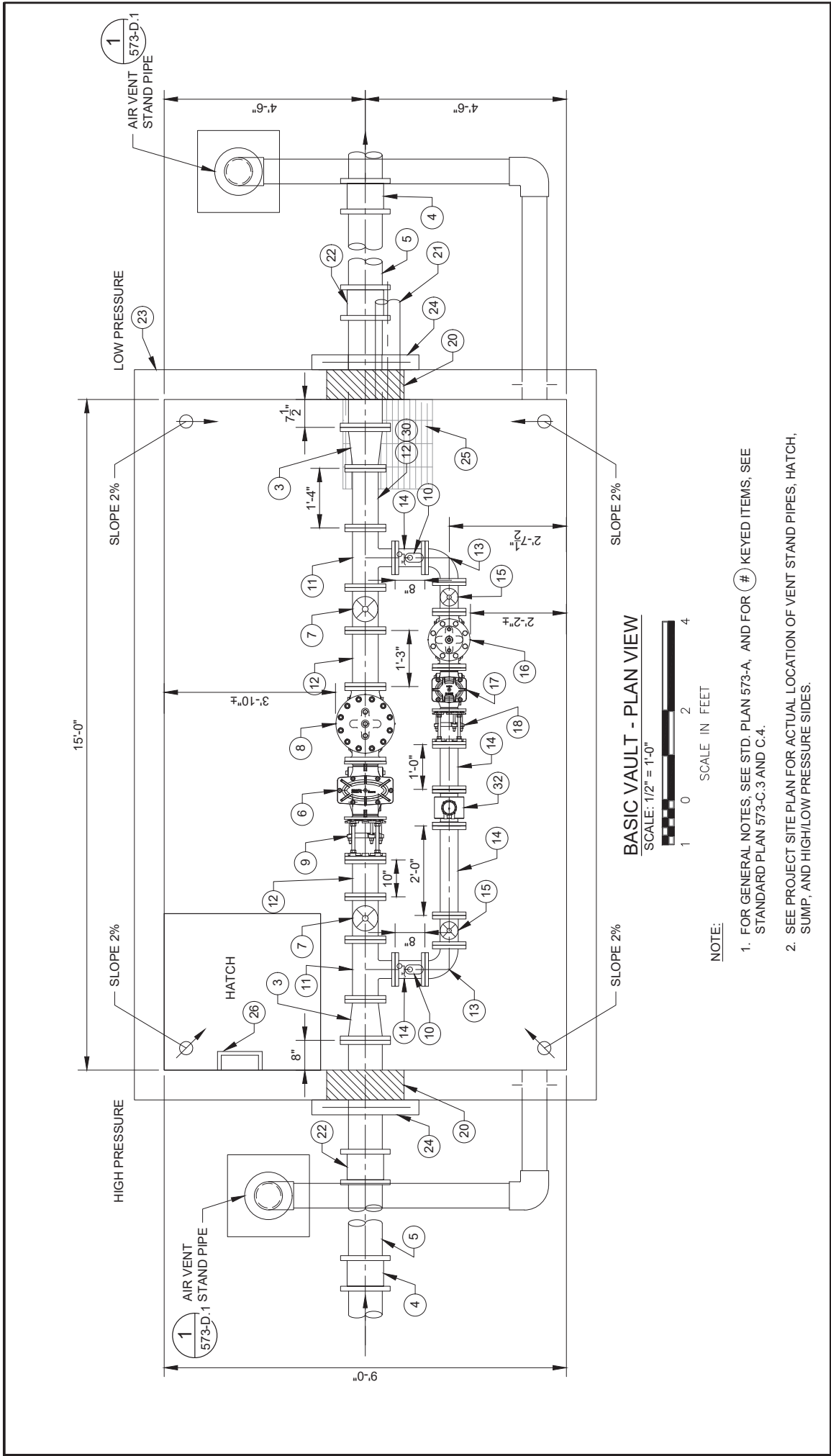

BASIC VAULT - PLAN VIEW

SCALE: 1/2" = 1'-0"

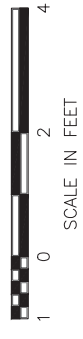

NOTE:

1. FOR GENERAL NOTES, SEE STD. PLAN 573-A, AND FOR (#) KEYED ITEMS, SEE STANDARD PLAN 573-C.3 AND C.4.
2. SEE PROJECT SITE PLAN FOR ACTUAL LOCATION OF VENT STAND PIPES, HATCH, SUMP, AND HIGH/LOW PRESSURE SIDES.

 PARK CITY MUNICIPAL CORPORATION WATER	DATE 03/2024	STD. PLAN 573-C.1
	REV. 2	PRESSURE REDUCING VALVE VAULT

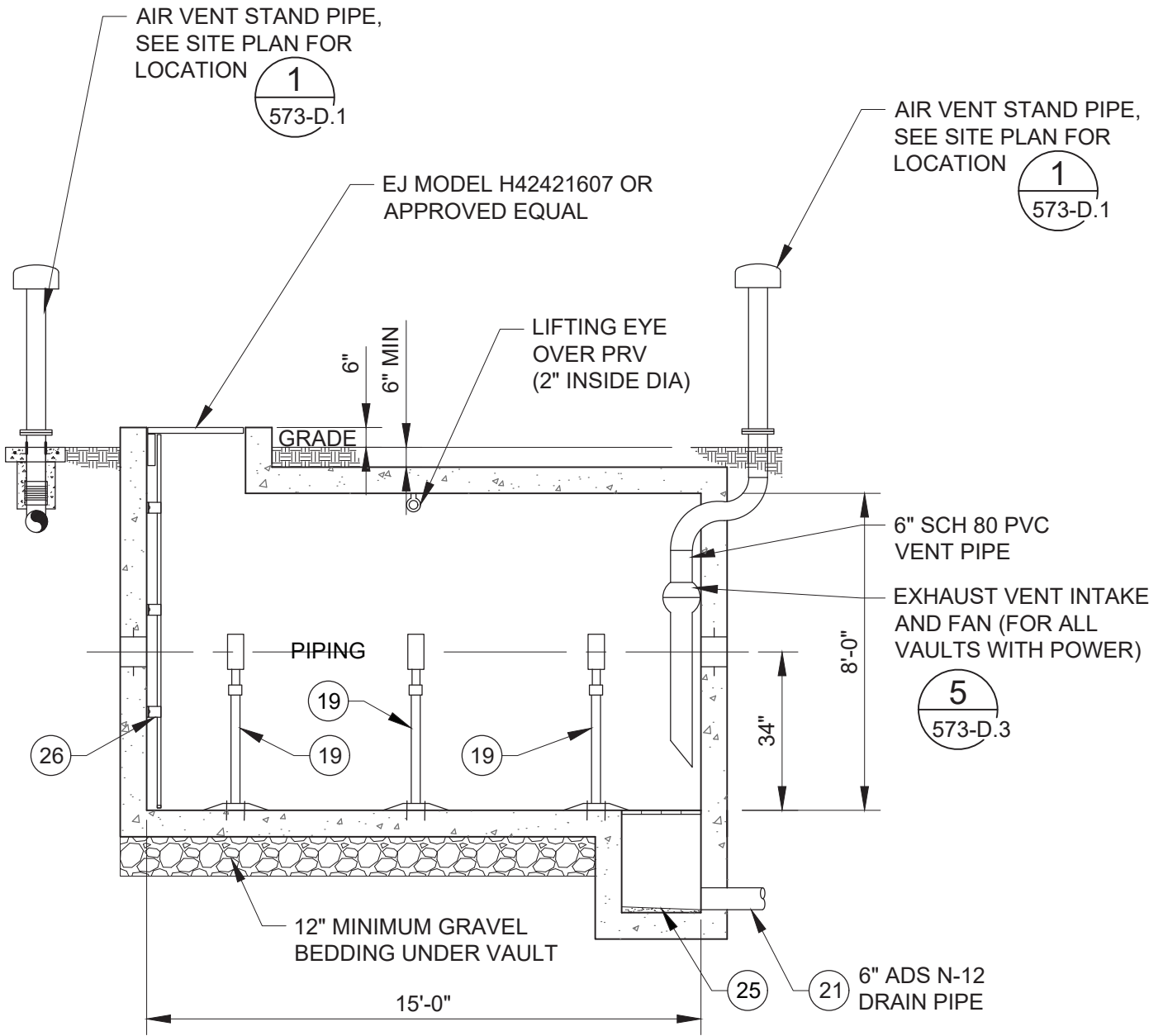

VAULT SECTION **(B)**
 NTS **(573-C.1)**

NOTES:

- FOR GENERAL NOTES, SEE STD. PLAN 573-A, AND FOR (#) KEYED ITEMS, SEE STD. PLAN 573-C.3 AND C.4.

 PARK CITY MUNICIPAL CORPORATION WATER	DATE	PRESSURE REDUCING VALVE VAULT	STD. PLAN
	03/2024		573-C.2
	REV.		
	1		

MATERIAL LIST

ITEM	PRESSURE REDUCING VALVE VAULT
①	INSTALL WATER MAIN WITH DI BENDS AS REQUIRED WITH RETAINER GLANDS AND THRUST BLOCKS
②	INSTALL RESILIENT SEAT VALVE, FL X MJ, W/ TEE AND RETAINER GLANDS AND TRUST BLOCKS ON EXISTING WATER MAIN, SEE STD PLAN 570
③	8"x6" DI REDUCER FL X FL
④	DI WATER MAIN, USE FLEXIBLE OR DUCTILE IRON MJ SLEEVES (POWERSEAL MODEL 3506 POWERMAX OR EQUAL) AS NECESSARY TO LEVEL EXISTING LINES
⑤	DUCTILE IRON PIPE (EXISTING PIPE SIZE)
⑥	6" CLA-VAL X 43 H (H STYLE STRAINER), FLANGED ENDS, 10 MESH SCREEN, CAGE SUPPORT, AND O-RING
⑦	6" RESILIENT WEDGE GATE VALVE, FL X FL WITH HAND WHEEL
⑧	6" PRESSURE REDUCING VALVE, CLA-VAL MODEL 92-01, FLANGE X FLANGE WITH MICRO-SWITCH (PRESSURE SUSTAINING VALVE IS REQUIRED UNLESS NOTED OTHERWISE) ALL BALL VALVES, WYE STRAINERS, PILOT CONTROLS, TRIM, SPEED CONTROLS AND ALL METALLIC INTERNAL COMPONENTS ARE TO BE STAINLESS STEEL. STAINLESS STEEL ANTI-CAVITATION MAY BE REQUIRED DEPENDING ON PRESSURE DIFFERENTIAL
⑨	6" DISMANTLING JOINT, ROMAC DJ 400, OR EQUAL
⑩	1" AIR VALVE AND PRESSURE TREE. SEE STD PLAN 573-D.1.
⑪	6"x6"x4" FL DI TEE
⑫	6" DI FL SPOOL
⑬	4" DI FL 90° BEND
⑭	4" DI FL SPOOL
⑮	4" RESILIENT WEDGE GATE VALVE, FLxFL WITH HAND WHEEL
⑯	4" PRESSURE REDUCING VALVE, CLA-VAL MODEL 92-01, FLANGE X FLANGE, (PRESSURE SUSTAINING VALVE IS REQUIRED UNLESS NOTED OTHERWISE) ALL BALL VALVES, WYE STRAINERS, PILOT CONTROLS, TRIM, SPEED CONTROLS AND ALL METALLIC INTERNAL COMPONENTS ARE TO BE STAINLESS STEEL. STAINLESS STEEL ANTI-CAVITATION TRIM MAY BE REQUIRED DEPENDING ON PRESSURE DIFFERENTIAL
⑰	4" CLA-VAL X 43H (H STYLE STRAINER), FLANGED ENDS, 10 MESH SST SCREEN, CAGE SUPPORT, AND O-RING
⑱	4" DISMANTLING JOINT, ROMAC DJ 400, OR EQUAL

 PARK CITY MUNICIPAL CORPORATION WATER	DATE	<h3 style="margin: 0;">PRESSURE REDUCING VALVE VAULT</h3>	STD. PLAN
	03/2024		<h2 style="margin: 0;">573-C.3</h2>
	REV.		
	2		

MATERIAL LIST (CON'T)

ITEM	PRESSURE REDUCING VALVE VAULT
(19)	2" STEEL PIPE SUPPORT STAND, ADJUSTABLE (3 REQUIRED ON 6" PIPE SYSTEM, 3 REQUIRED ON 4" PIPE SYSTEM), SEE STD. PLAN 578
(20)	CORE DRILL OPENING WITH LINK-SEAL PIPE-TO-WALL SEAL. TYPICAL ON ALL OPENING. FILL OUTSIDE OPENINGS WITH NON-SHRINK GROUT AND CAULK
(21)	DRAIN SUMP, PIPE TO DAYLIGHT WITH DRAIN PIPE AND #4 SST RODENT PROTECTION SCREEN ON END OF PIPE. ROUTE AS SHOWN ON SITE PLAN. IF NO PIPE-TO-DAYLIGHT OPTION IS AVAILABLE, INSTALL A SUMP PUMP. CITY APPROVAL IS REQUIRED FOR A SUMP PUMP. SEE STD. PLAN 573-D.2
(22)	8" MJ SOLID SLEEVE, MEGA-LUG RESTRAINTS WITH CORE-TEN BOLTS
(23)	VAULT IN ACCORDANCE WITH 573-A AND 573-B A. PRECAST CONCRETE VAULT RATED FOR HS-20 LOADING. MAY BE CAST IN PLACE PER CITY APPROVAL. PROVIDE STAMPED STRUCTURAL DRAWINGS B. WATERPROOF OUTSIDE WALLS AND TOP SLAB PER IBC CODE FOR BURIED FOUNDATIONS
(24)	MECHANICAL JOINT DUCTILE IRON RETAINER GLAND WITH CONCRETE THRUST BLOCK, REINFORCE CONCRETE WITH (4) #4 EACH SIDE OF PIPE.
(25)	30"x30"x30" SUMP. FRP GRATING, 1-1/2" THICK MIN. AND RATED FOR 300 LB/FT PEDESTRIAN TRAFFIC.
(26)	VAULT LADDER, SEE DETAIL 7 ON 573-D.4
(27)	3" PRESSURE RELIEF VALVE, CLA-VAL MODEL 50A-01 BKCX WITH MOUNTED LIMIT SWITCH OR MICRO SWITCH WITH SCADA CONNECT FOR "OPEN" ALARM CONDITION, SEE STD. PLAN 573-D.2
(28)	IN-LINE GAUGE PRESSURE TRANSMITTER, ROSEMOUNT MODEL 3051TG 800 PSI ASSEMBLED TO INTEGRAL, 2-VALVE, ROSEMOUNT 306 MANIFOLD. SEE STD. PLAN 573-D.1. 4-20 MA ANALOG
(29)	6"x6"x3" DI TEE FLANGE X FLANGE X FLANGE
(30)	6" DI PIPE. IF VAULT HAS POWER, THIS ITEM SHALL BE REPLACED WITH ITEMS 29 AND 27.
(31)	SUMP PUMP: 2" SUMP PUMP, TSURUMI MODEL HSZ2.4S-62 OR EQUAL. SUMP PUMP REQUIRED IF DRAIN TO DAYLIGHT NOT AVAILABLE, SEE STD. PLAN 573-D.2
(32)	4" SIEMENS MAGNETIC FLOW METER, 5100 W

 PARK CITY MUNICIPAL CORPORATION WATER	DATE	<h3 style="margin: 0;">PRESSURE REDUCING VALVE VAULT</h3>	STD. PLAN
	03/2024		<h2 style="margin: 0;">573-C.4</h2>
	REV.		
	2		

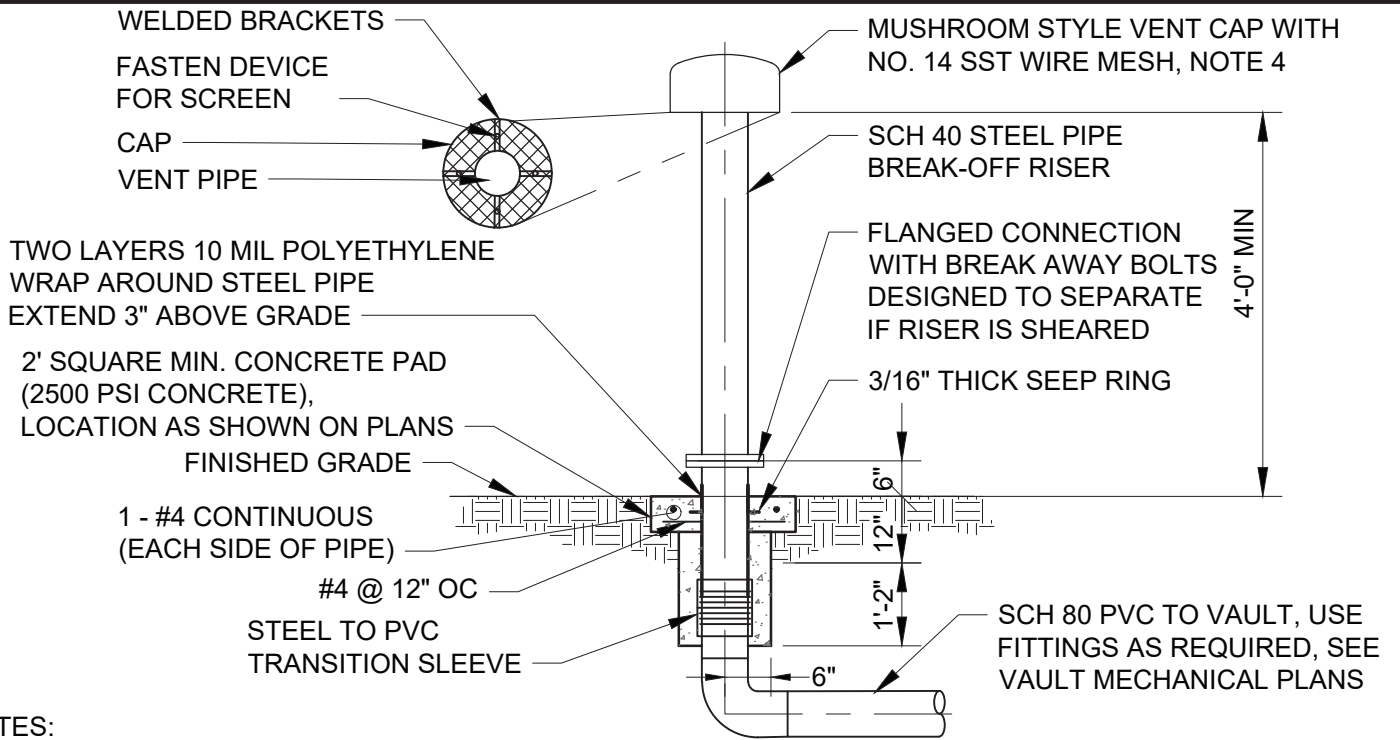

NOTES:

1. WELD ALL STEEL FITTINGS EXCEPT MATCHING BOLT ON FLANGE.
2. ALL ABOVE GRADE STEEL PIPING SHALL BE CORE-TEN BARE STEEL.
3. VENT CAP SHALL BE 12" DIA FOR 6" VENT PIPE. OTHER SIZES SHALL BE PROJECT SPECIFIC.
4. STEEL WALL PIPE WITH SEEP RING SHALL BE CAST IN VAULT FOR VENT PIPES INSTALLED ON TOP OF VAULTS.

AIR VENT STAND PIPE
NTS

1
573-B, 573-C

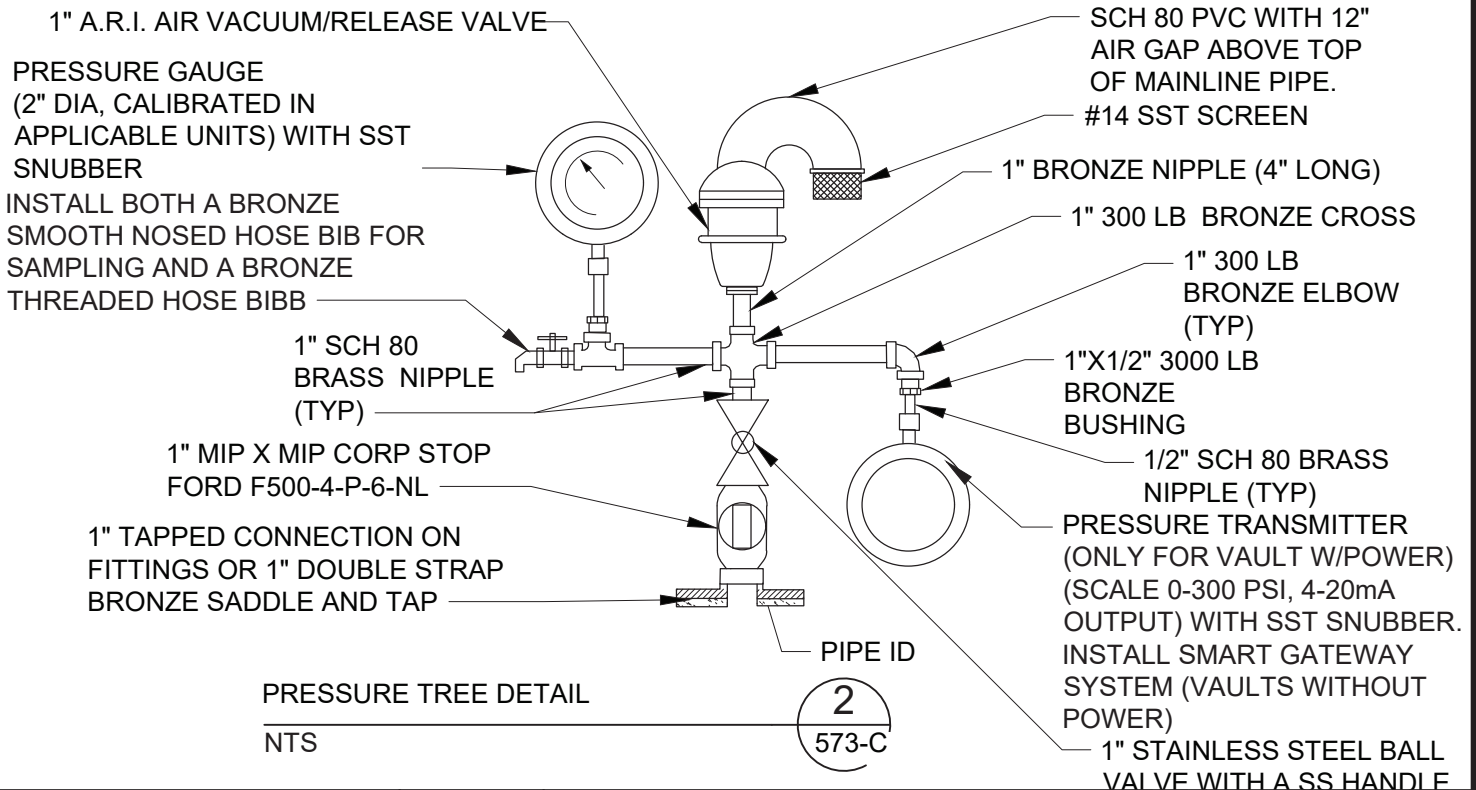

PRESSURE TREE DETAIL
NTS

2
573-C

 PARK CITY MUNICIPAL CORPORATION WATER	DATE	PRESSURE REDUCING VALVE VAULT	STD. PLAN
	03/2024		573-D.1
	REV.		
	2		

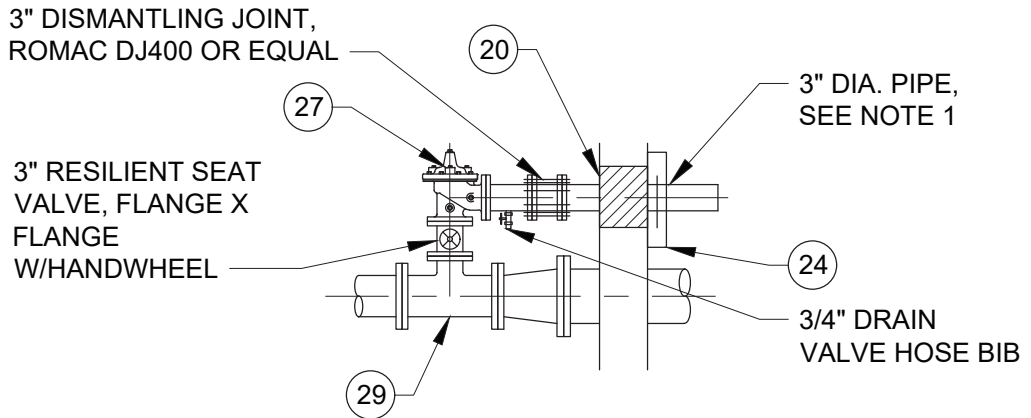

NOTES:

1. ROUTE TO NEAREST APPROVED DISCHARGE LOCATION WITH 12" AIR GAP AND #4 SST MESH SCREEN BETWEEN FLANGES AND EROSION CONTROL. ALL FITTINGS MUST BE FLANGED OR RESTRAINED. 5' MIN COVER.
2. FOR GENERAL NOTES, SEE STD. PLAN 573-A, AND FOR (#) KEYED ITEMS, SEE STD. PLAN 573-C.3 AND C.4

3" PRESSURE RELIEF VALVE DETAIL

NTS

3
573-C

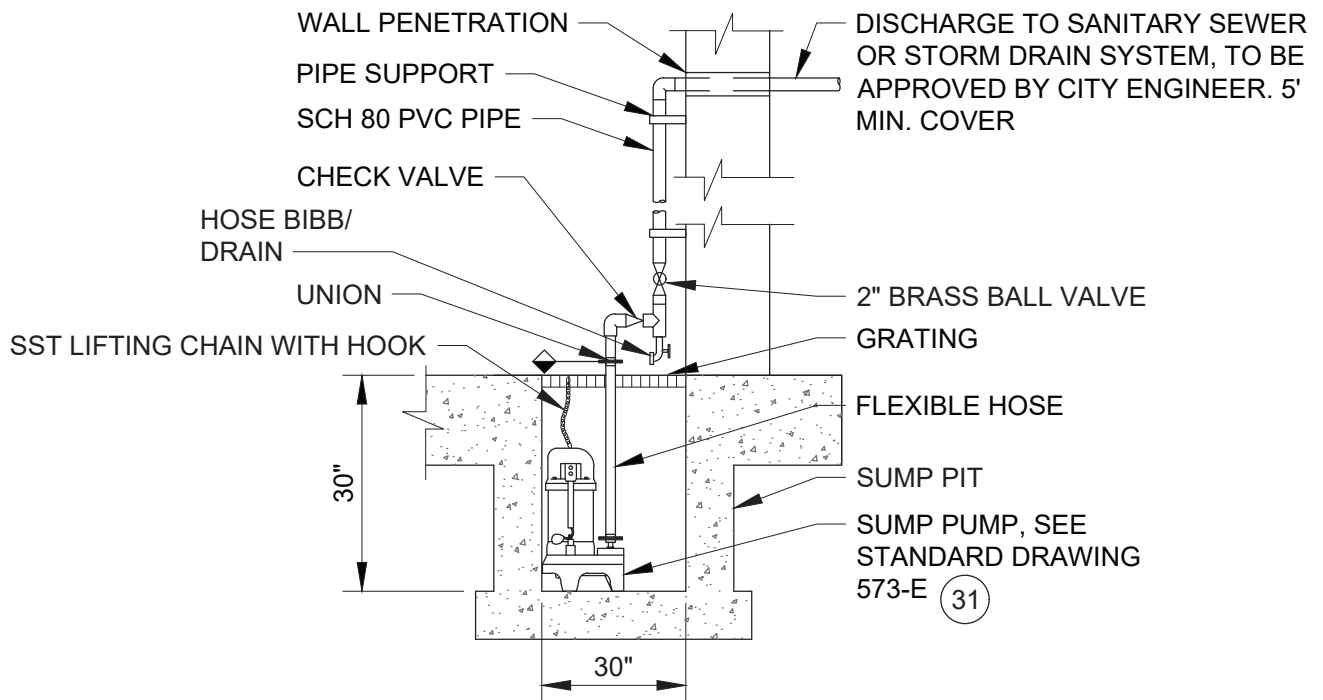

NOTES:

1. SUMP PUMP AND DISCHARGE PIPING SHALL NOT BE USED UNLESS SPECIFICALLY APPROVED BY THE CITY. SUMP SHALL DRAW TO DAYLIGHT UNLESS OTHERWISE APPROVED.
2. FOR GENERAL NOTES, SEE STD. PLAN 573-A, AND FOR (#) KEYED ITEMS, SEE STD. PLAN 573-C.3 AND C.4

TYPICAL SUMP SECTION DETAIL

NTS

4
573-C



PARK CITY MUNICIPAL CORPORATION
WATER

DATE

03/2024

REV.

1

**PRESSURE REDUCING
VALVE VAULT**

STD. PLAN

573-D.2

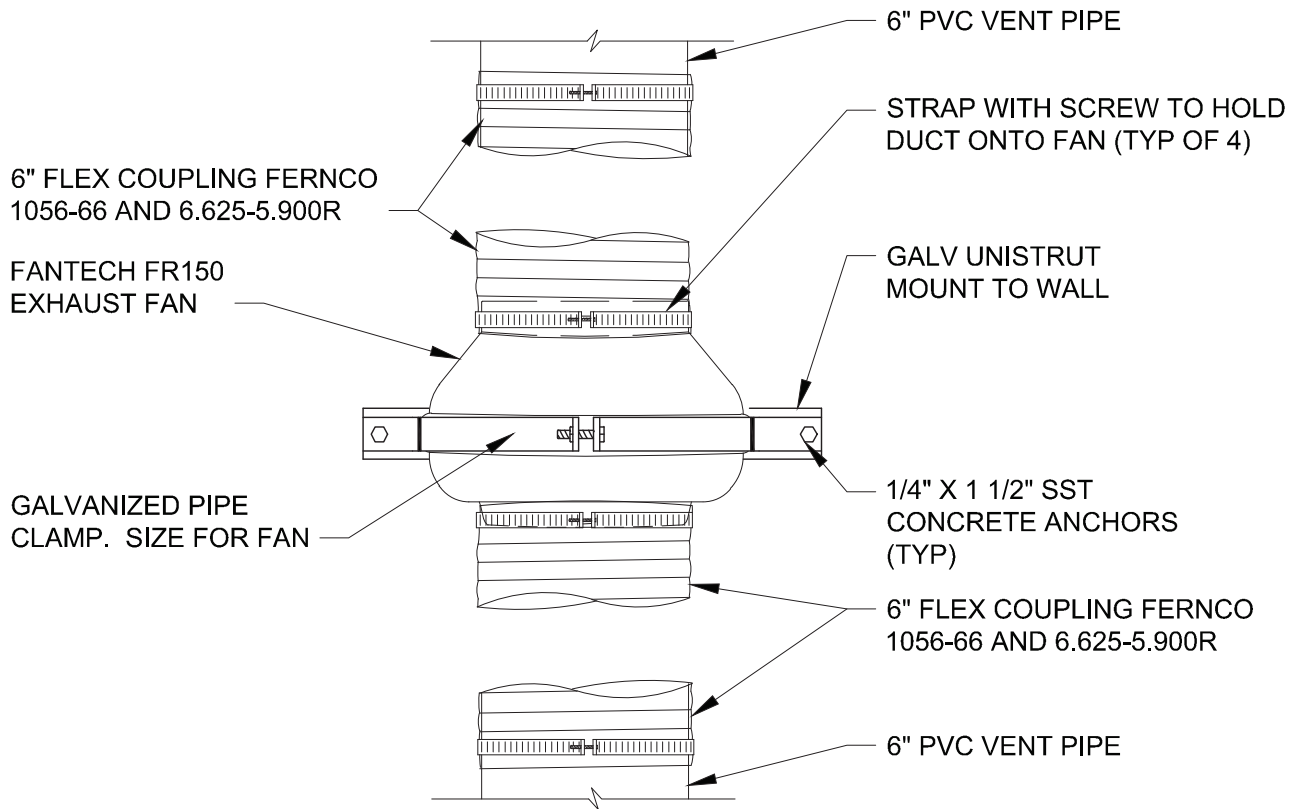

IN-LINE EXHAUST FAN DETAIL

5
573-C, 573-E

NTS

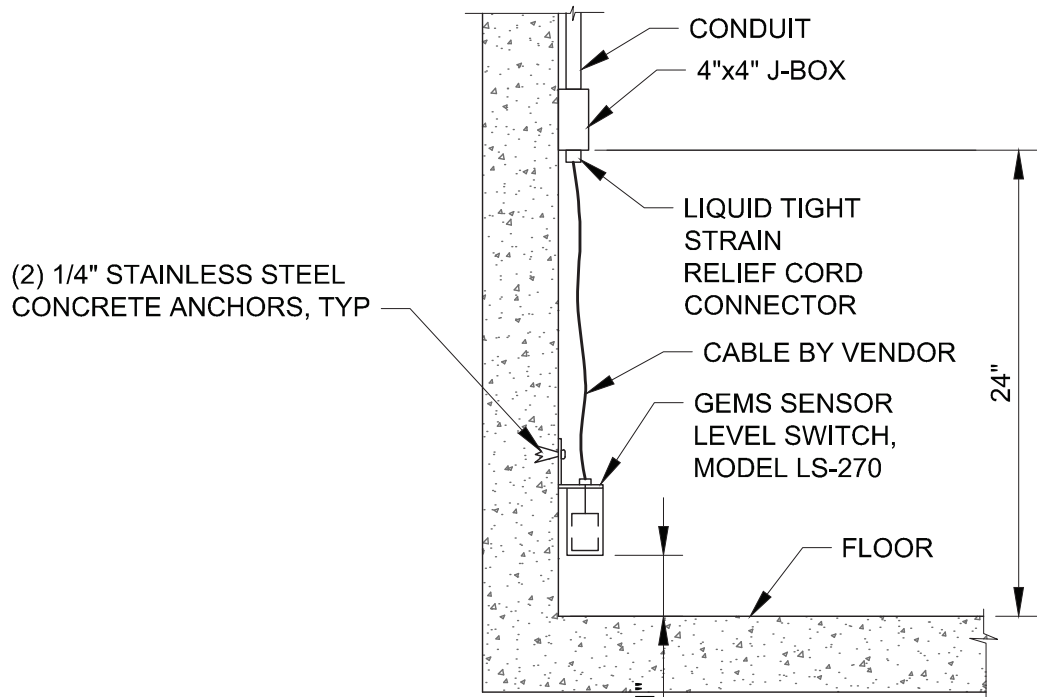

FLOOD SWITCH INSTALLATION DETAIL

6
573-E

NTS



DATE	4/2014
REV.	0

PRESSURE REDUCING VALVE VAULT

STD. PLAN

573-D.3

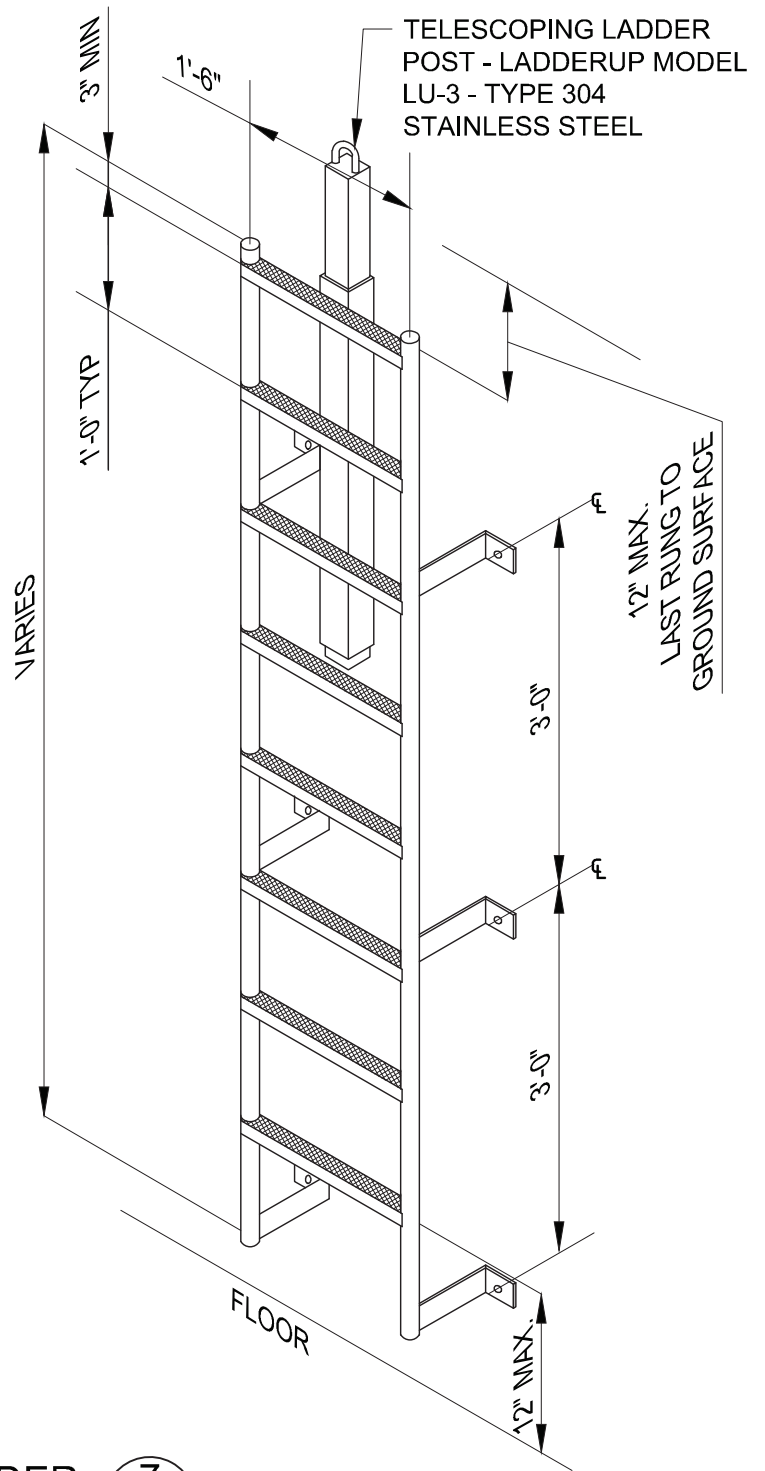
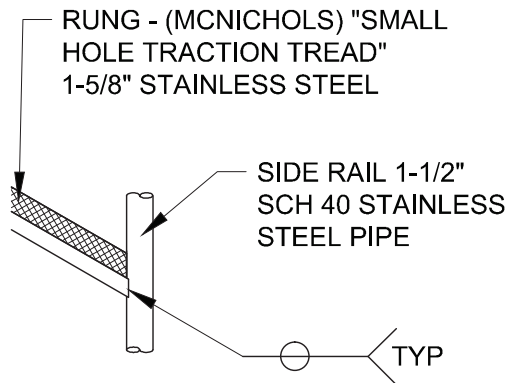
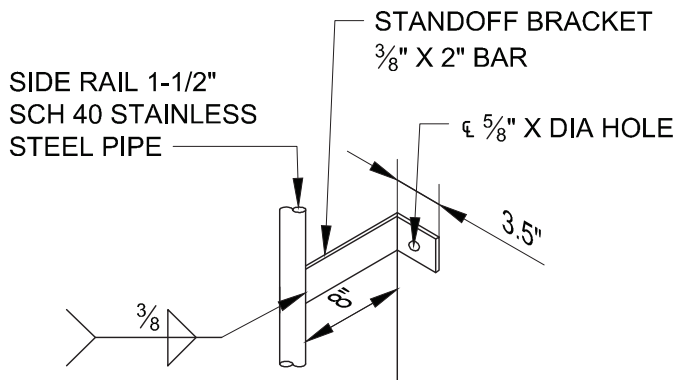

VAULT LADDER

7
573-C

NTS

NOTE:

- LADDER, ANCHORS, AND BOLTS TO BE STAINLESS STEEL

 PARK CITY MUNICIPAL CORPORATION WATER	DATE	PRESSURE REDUCING VALVE VAULT	STD. PLAN
	4/2014		573-D.4
	REV.		
	0		

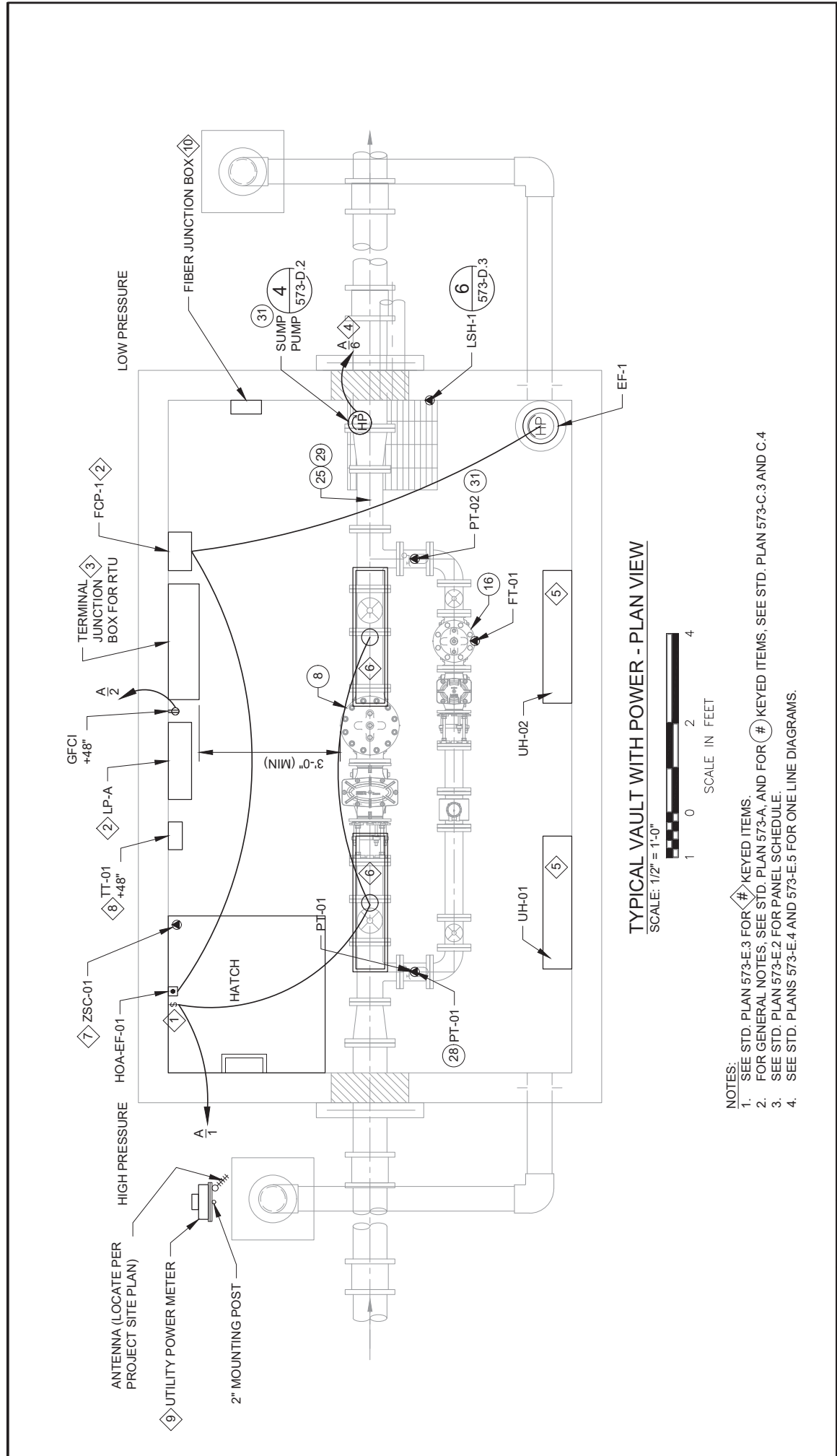

TYPICAL VAULT WITH POWER - PLAN VIEW

SCALE: 1/2" = 1'-0"

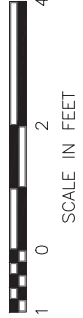

- NOTES:
1. SEE STD. PLAN 573-E.3 FOR # KEYED ITEMS.
 2. FOR GENERAL NOTES, SEE STD. PLAN 573-A, AND FOR # KEYED ITEMS, SEE STD. PLAN 573-C.3 AND C.4.
 3. SEE STD. PLAN 573-E.2 FOR PANEL SCHEDULE.
 4. SEE STD. PLANS 573-E.4 AND 573-E.5 FOR ONE LINE DIAGRAMS.

 PARK CITY MUNICIPAL CORPORATION WATER	DATE 03/2024	STD. PLAN 573-E.1
	REV. 1	PRESSURE REDUCING VALVE VAULT

PANEL SCHEDULE LP-A

LOCATION: IN VAULT	MFGR: CULTER HAMMER OR EQUAL	100 AMPS	VOLTS: 120/240
DIMENSIONS: SIZE BY CONTRACTOR	TYPE: PANELBOARD	M.L.O.	PHASE: 1
MOUNTING: SURFACE	NEMA: 3R	50 M.C.B.	WIRES: 3
FEED: TOP		10000 A.I.C.	

						PHASE LOADS									
BRKR		DESCRIPTION	CONT. WATT S	N-CONT. WATTS	NO	A		B		NO	N-CONT. WATTS	CONT. WATTS	DESCRIPTION	BRKR	
A	P					CONT.	N-CONT.	CONT.	N-CONT.					A	P
20	1	LIGHTS		148	1	0	328			2	180		OUTLETS	15	1
20	1	RTU		500	3			0	1246	4	746		SUMP PUMP OUTLET	20	1
20	2	UNIT HEATER (UH-1)	1000		5	500	0	500	0	6	560		FAN CONTROL PANEL	20	1
20	2	UNIT HEATER (UH-2)	1000		7	500	0	500	0	8			SPARE	20	1
20	1	SPARE			9	0	0			10			SPARE	20	1
20	1	SPARE			11			0	0	12			SPACE		
		SPACE			13	0	0			14			SPACE		
		SPACE			15			0	0	16			SPACE		
		SPACE			17					18			SPACE		

TOTAL WATTS:	2000	648	1,000	328	1,000	1246	1,486	0
CONTINUOUS LOAD:	2000							
CONTINUOUS LOAD *125%:	2,500							
NON-CONTINUOUS LOAD:	2,134							
DESIGN WATTS:	4,634							
MIN. RATING (AMPS):	13							

 PARK CITY MUNICIPAL CORPORATION WATER	DATE	<h3 style="margin: 0;">PRESSURE REDUCING VALVE VAULT</h3>	STD. PLAN
	03/2024		573-E.2
	REV.		
	1		

PANEL NOTE:

- ① INSTALL WEATHERPROOF LIGHT SWITCH AND NEMA 4X HOA CONTROL BOX IN HATCH OPENING ABOUT 8" FROM TOP OF CONCRETE.
- ② MAINTAIN NATIONAL ELECTRICAL CODE REQUIRED CLEARANCE AND WORKING SPACE AROUND PANELS.
- ③ COORDINATE WITH PCMC FOR RTU PANEL, ANTENNA, AND CABLE REQUIREMENTS. CONTRACTOR TO FURNISH AND INSTALL RTU PANEL, ANTENNA, ANTENNA MAST, CONDUIT, CONDUCTOR, AND CABLE WITH WIRING TERMINATIONS INSIDE THE RTU PANEL. CONTRACTOR TO SIZE RTU RELATED EQUIPMENT FOR 11 I/O POINTS INCLUDING 3 SPARES. (1 FLOW METER, 2 PRESSURE TRANSDUCERS, 1 TEMPERATURE SENSOR, 1 FLOOD ALARM, 1 ENTRY SECURITY ALARM, 1 PRESSURE RELIEF OPEN ALARM, 2 SPARE DIGITAL INPUTS AND 2 SPARE ANALOG INPUTS). CONTRACTOR MUST USE PCMC'S PREFERRED VENDOR TO PROVIDE AND INSTALL A PRE-ASSEMBLED AND PRE-WIRED BACKPANEL IN THE RTU PANEL AND PROVIDE SCADA PROGRAMMING.
- ④ SUMP PUMP TO BE HARDWIRED TO PANEL LP-A.
- ⑤ INSTALL 4-FOOT BASEBOARD HEATER AT 2-FEET ABOVE FINISHED FLOOR OF VAULT. HEATER SHALL BE 240 V WITH 3,400 BTUH, INTEGRAL DIAL THERMOSTAT.
- ⑥ GASKETED AND ENCLOSED INDUSTRIAL FIXTURE, FIBERGLASS HOUSING, WET LOCATION TWO LAMP FLUORESCENT, 120 VOLT, INSTANT START ELECTRONIC BALLAST METALUX VT3-232DR-120V-EB81-WL-U OR EQUAL. MOUNT FIXTURE ON WALL AT ABOUT 7 FEET ABOVE FINISHED FLOOR.
- ⑦ NEMA 4 HEAVY-DUTY LIMIT SWITCH WITH 1NO 1NC CONTACT 5A 120 VAC. SQUARE D COMPANY, CLASS 9007 OR EQUAL.
- ⑧ ROOM TEMPERATURE DISPLAY AND 4-20 mA TRANSMITTER WITH 100 OHM PLATINUM RTD. DEVAR MODEL D-RTTI-0024.
- ⑨ INSTALL UTILITY POWER METER WITH 50 AMP BREAKER ON BACK TO BACK UNISTRUT TO 2" GALVANIZED STEEL POLE ACCORDING TO UTILITY COMPANY STANDARDS.
- ⑩ IF FIBER IS AVAILABLE, INSTALL JUNCTION BOX FOR FIBER CONNECTION. COORDINATE SIZE OF BOX WITH PROVIDER.

 <p>PARK CITY 1884 PARK CITY MUNICIPAL CORPORATION WATER</p>	DATE	<p>PRESSURE REDUCING VALVE VAULT</p>	STD. PLAN
	05/2025		<p>573-E.3</p>
	REV.		
	3		

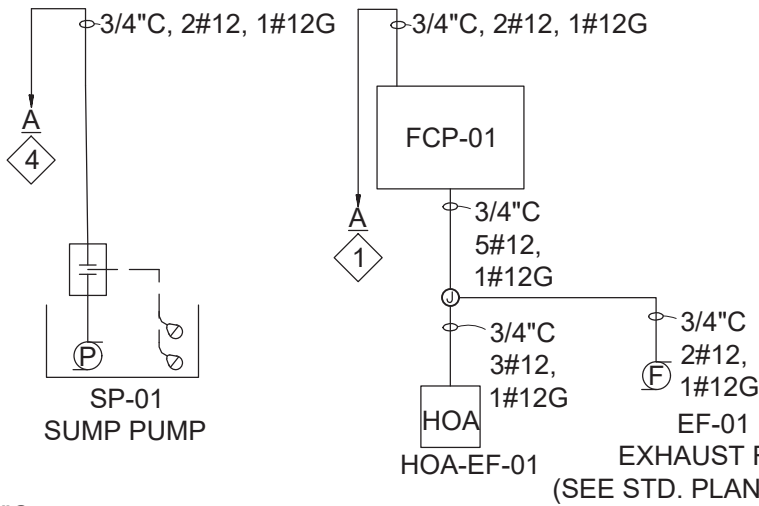

GENERAL NOTES:

1. REFER TO STD. PLAN 573-E.1 FOR EQUIPMENT LOCATIONS, 573-E.2 FOR PANEL SCHEDULE, AND 573-E.3 FOR # KEYED ITEMS.

LEGEND

- AI - ANALOG INPUT
- DI - DIGITAL INPUT
- TSP - TWISTED SHIELDED PAIR CABLE

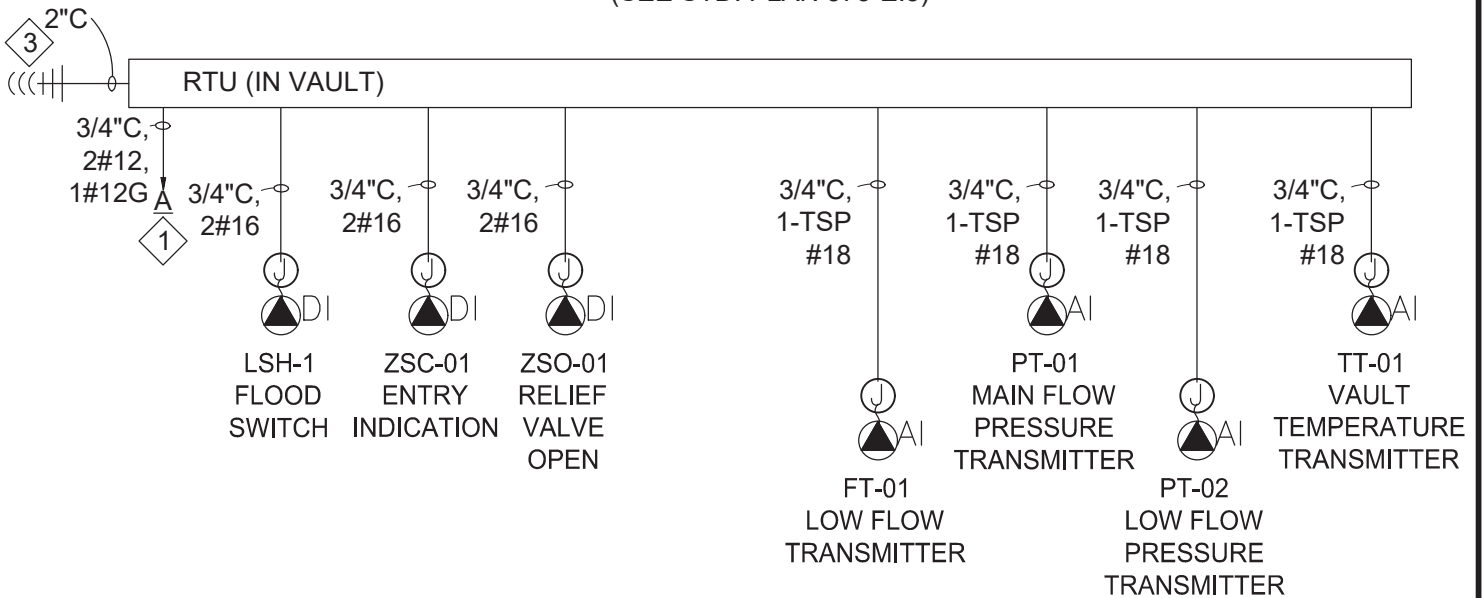

CONTROL ONE-LINE DIAGRAM

<p>PARK CITY MUNICIPAL CORPORATION WATER</p>	DATE	<p>PRESSURE REDUCING VALVE VAULT</p>	STD. PLAN
	03/2024		<p>573-E.4</p>
	REV.		
	1		

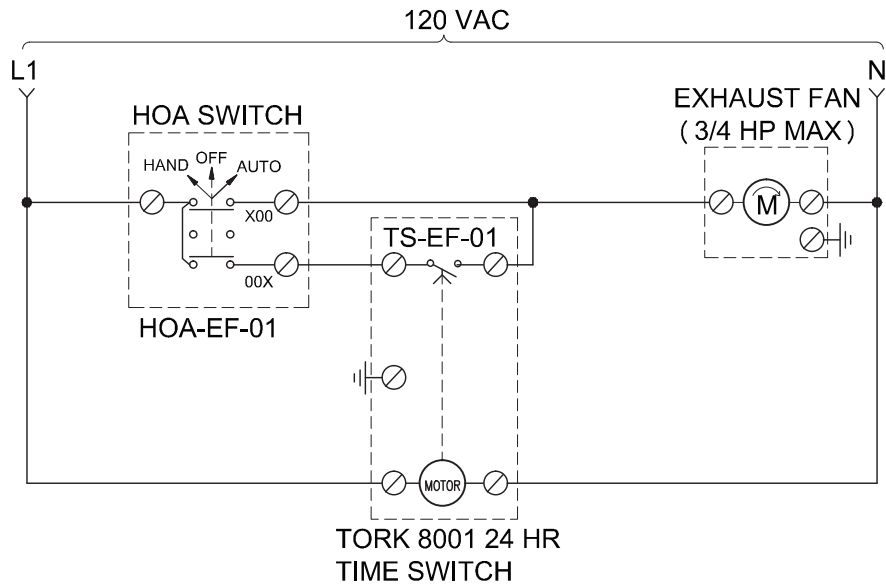

TYPICAL VAULT EXHAUST FAN CONTROL SCHEMATIC

NTS

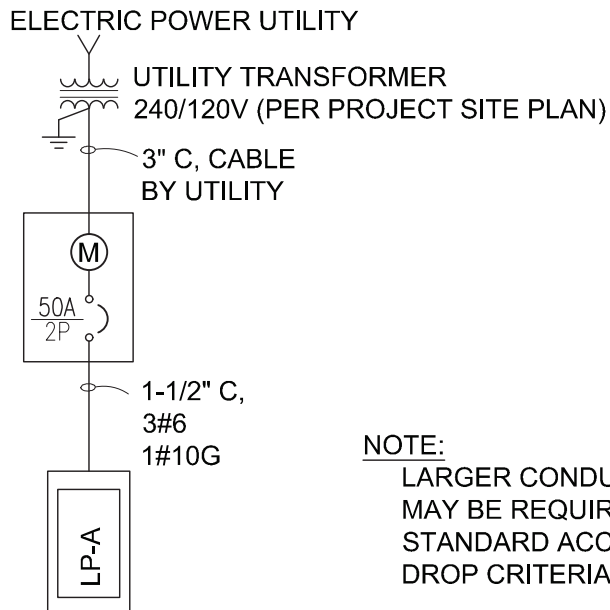

POWER ONE-LINE

NTS



PARK CITY MUNICIPAL CORPORATION
WATER

DATE

4/2014

REV.

0

PRESSURE REDUCING VALVE VAULT

STD. PLAN

573-E.5

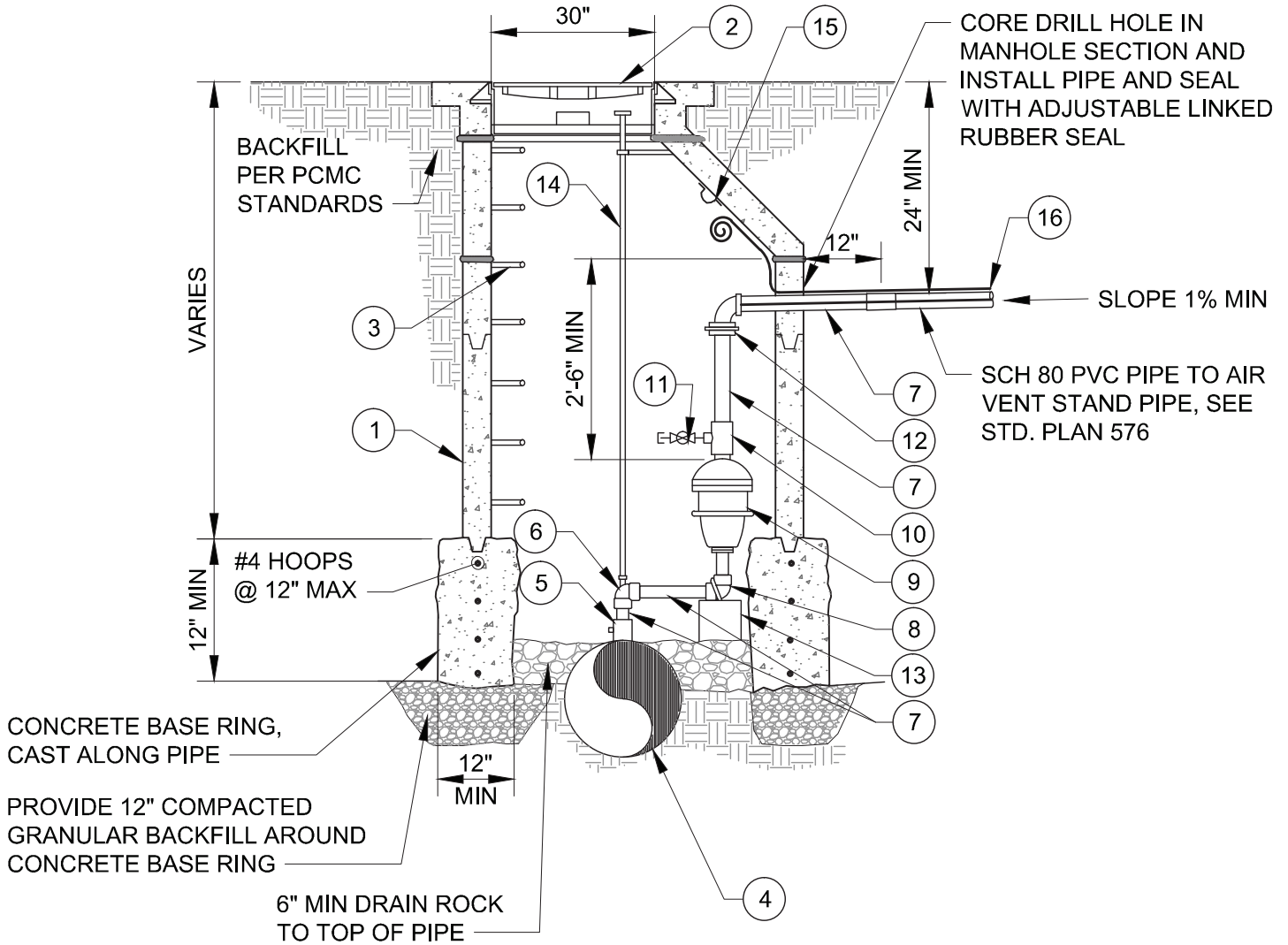

PARK CITY MUNICIPAL CORPORATION
WATER

DATE

3/2014

REV.

0

AIR RELEASE / CAV VALVE MANHOLE

STD. PLAN

574

LEGEND AND APPROVED PARTS LIST

ITEM	DESCRIPTION	ACCEPTABLE MANUFACTURER	MODELS
①	5' DIA. MANHOLE, PRECAST CONCRETE ECCENTRIC CONE AND WALL SECTIONS		ASTM C 478
②	MANHOLE FRAME AND COVER (STD. PLAN 529)		
③	POLYPROPYLENE ENCASED GRADE 60 STEEL STEPS AT 13" C-C, 13-1/2" TREAD WIDTH	M.A. INDUSTRIES OR APP'D EQUAL	PS2-PFDF
④	VALVE LARGER THAN 2": DUCTILE IRON FLANGED TEE WITH 4" BLIND FLANGE BRONZE AND NPT SERVICE TAP VALVE 2" AND SMALLER: BRONZE SERVICE SADDLE DI MAIN; DOUBLE STRAP PVC MAIN; TWO-PIECE BOLTED	MUELLER	DI PIPE SADDLE: BR2B SERIES, I.P. THDS; PVC PIPE SADDLE: H-13000 SERIES, I.P. THDS
		FORD	DI PIPE SADDLE: STYLE 202B I.P. THDS; PVC PIPE SADDLE: STYLE S92, I.P. THDS
⑤	BRASS CORPORATION STOP, INLET I.P. THREAD, OUTLET F.I.P. THREAD (VALVE INLET SIZE)	MUELLER	B-20046N
		FORD	FB1100-(SERVICE SIZE)-Q-NL
⑥	BRONZE ANGLE VALVE, 300 PSI (VALVE INLET DIAMETER)		
⑦	BRASS NIPPLES X LENGTH AS REQUIRED, M.I.P., (VALVE INLET DIAMETER)		
⑧	BRASS 90° ELBOW, F.I.P. (VALVE INLET/OUTLET DIAMETER)		
⑨	COMBINATION AIR VACUUM / RELEASE VALVE, NPT, SIZE PER ENGINEER DESIGN AND APPROVED PLANS		
⑩	BRONZE TEE, F.I.P., THREADED, (VALVE OUTLET DIAMETER X 3/4" DIA.)		
⑪	DRAIN ASSEMBLY: 3/4" DIA. BRASS CLOSE NIPPLE, M.I.P.; 3/4" BRONZE BALL VALVE; 3/4" BRONZE PLUG	MUELLER	SERIES 300 VALVE; H-10035
⑫	BRONZE UNION, (VALVE OUTLET DIAMETER)		
⑬	CAV ASSEMBLY SUPPORT, (1) 16"X8"X8" CMU BLOCK		
⑭	5/8" DIAMETER GALVANIZED STEEL ROD WITH 3" DIAMETER HAND WHEEL TO FORM EXTENSION, TOGETHER WITH A GALVANIZED EYELET STANDOFF		
⑮	LIFTING EYE ABOVE AIR VALVE, GALVANIZED		
⑯	TRACER WIRE: 12 GA. SOLID, BLUE PVC INSULATION; WIRE-WIRE CONNECTORS SILICONE-FILLED WIRE NUTS	IDEAL INDUSTRIES	TWISTER DB PLUS OR APP'D EQUAL

DETAIL NOTES

1. ALL VALVES AND FITTINGS SHALL BE RATED FOR THE SAME WORKING AND TEST PRESSURES AS THE CONNECTED WATERLINE
2. LOCATE VALVE, VAULT, AND AIR VENT PER APPROVED PLANS AND SET VAULT PLUMB
3. REFER TO STD. PLAN 575 FOR HEAT TRACE REQUIREMENTS

 PARK CITY MUNICIPAL CORPORATION WATER	DATE	AIR RELEASE / CAV VALVE MANHOLE	STD. PLAN
	10/2020		574 S
	REV.		
	1		

KEY NOTES:

- 1 WRAP HEAT TAPE AROUND THE AIR/VAC VALVE. USE MANUFACTURER'S RECOMMENDATIONS FOR THE NUMBER OF WRAPS.
- 2 SECURE THE HEATING CABLE IN PLACE WITH CHROMALOX FT-3 FIBERGLASS TAPE.
- 3 END KIT WITH INDICATING LIGHT.
- 4 INSULATE THE ISOLATION VALVE AND THE COMBINATION AIR VACUUM RELEASE VALVE WITH A REMOVABLE AND REUSABLE INSULATING BLANKET. ENERGY-WRAP INSULATION SYSTEM AS MANUFACTURED BY THERMAL ENERGY PRODUCTS.
- 5 INSTALL CHROMALOX AT-1 ALUMINUM TAPE NEXT TO PVC PIPE BEFORE INSTALLING HEAT TAPE AND THEN THE HEAT TAPE WILL CONTINUE FROM THE AIR/VAC VALVE AND LAY ALONG THE ALUMINUM TAPE.
- 6 INSULATE THE PIPE WITH 2 INCH THICK FIBERGLASS PIPE INSULATION.

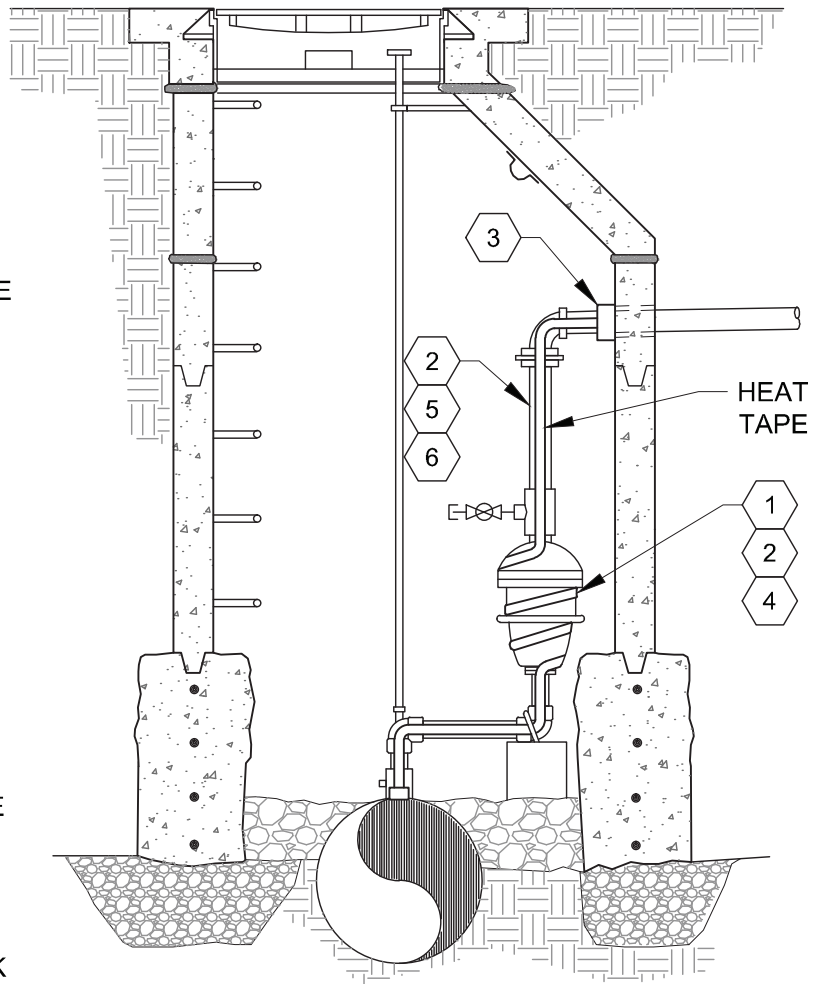

NOTES:

- 1. INSTALL HEAT TAPE IN ACCORDANCE WITH MANUFACTURER'S RECOMMENDATIONS.
- 2. REFER TO STD. PLAN 575-B FOR POWER ONE-LINE DETAIL.
- 3. SEE AIR RELEASE / CAV VALVE MANHOLE, STD. PLAN 574

 PARK CITY MUNICIPAL CORPORATION WATER	DATE	HEAT TAPE INSTALLATION FOR AIR RELEASE / CAV VALVE	STD. PLAN
	3/2014		575-A
	REV.		
	0		

KEY NOTES:

- 1 TYPE 4X NONMETALLIC J-BOX FOR WIRE CONNECTIONS AS NEEDED.
- 2 CROUSE HINDS FS BOX, WITH 20 AMP SINGLE POLE SWITCH, AND A CROUSE HINDS P/N DS185 COVER.
- 3 CHROMALOX NON INDICATING TEMPERATURE CONTROL, 0 TO 150 DEGREES F, P/N PIT-15.
- 4 CHROMALOX PIPE MOUNTED POWER CONNECTION BOX NEMA 4X, P/N RTPC.
- 5 HEAT TAPE 120 VOLT, 5 WATTS PER FOOT, SELF-REGULATING, TINNED COPPER BRAID, WITH A FLUOROPOLYMER OVERJACKET. CONNECT GROUNDING CONDUCTOR TO COPPER BRAID. CHROMALOX P/N SRL 5-1CT HEATING CABLE.
- 6 END KIT WITH INDICATING LIGHT 120 VOLT, CHROMALOX P/N RTPC-SL1.
- 7 3/4" RIGID CONDUIT GALVANIZED WITH TWO #12 CONDUCTORS AND ONE #12 GROUND.
- 8 1/2" RIGID CONDUIT GALVANIZED WITH TWO #12 CONDUCTORS AND ONE #12 GROUND.
- 9 3/4" RIGID T CONDUIT GALVANIZED BODY WITH ONE REDUCER FOR 1/2" CONDUIT.

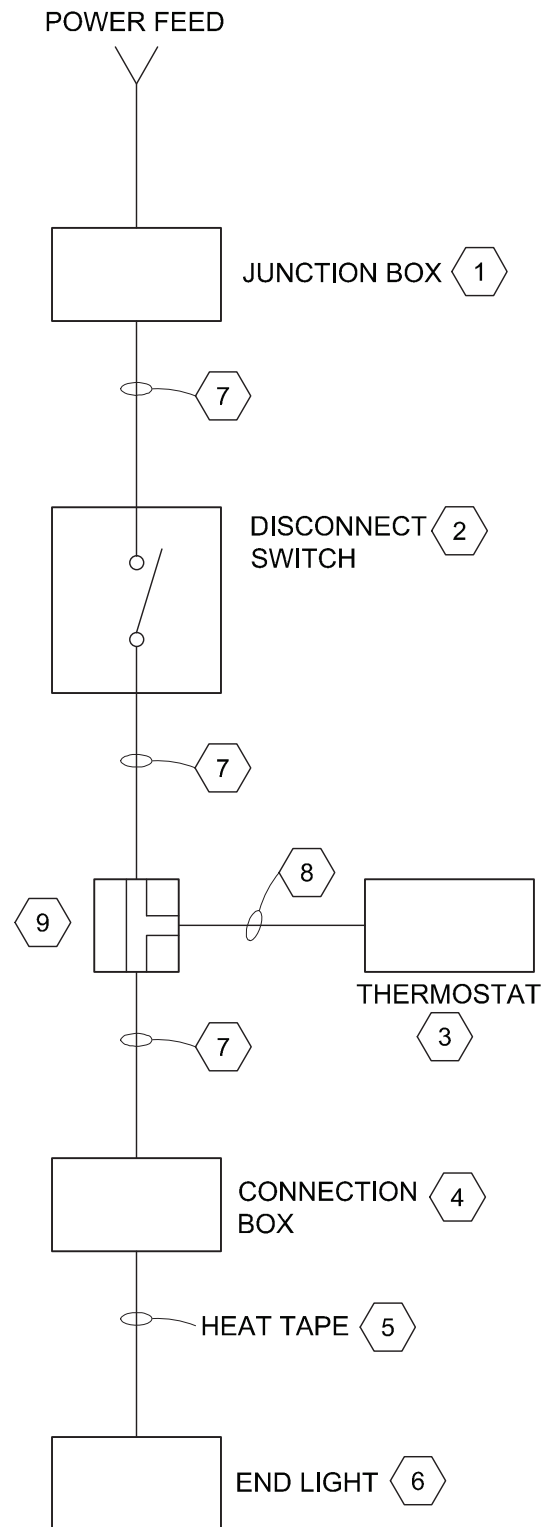

HEAT TRACE POWER ONE-LINE DETAIL

 PARK CITY MUNICIPAL CORPORATION WATER	DATE	HEAT TAPE INSTALLATION FOR AIR RELEASE / CAV VALVE	STD. PLAN
	3/2014		575-B
	REV.		
	0		

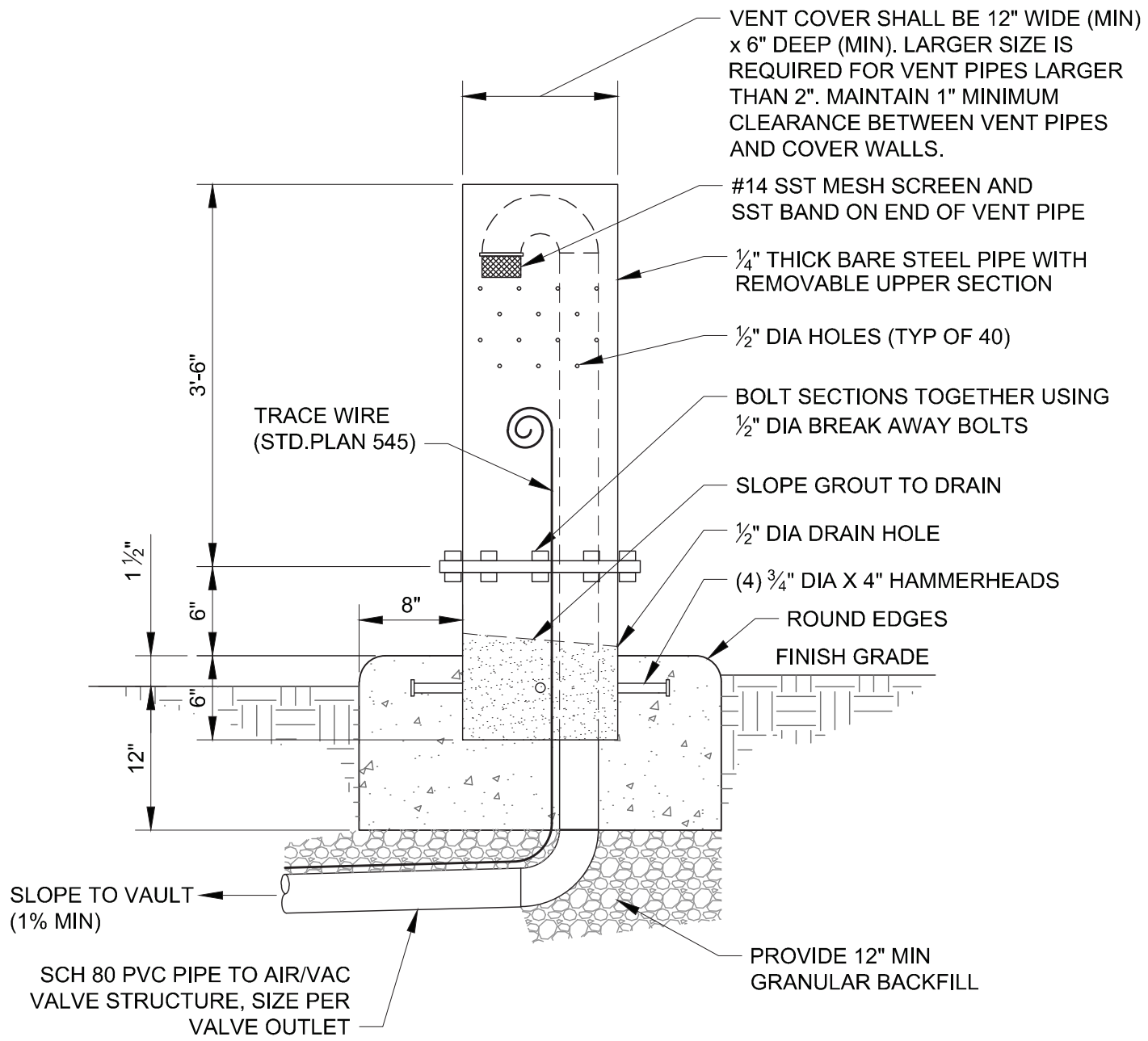

NOTES:

1. LOCATE VENT AS SHOWN ON APPROVED PLANS, 1'-6" MINIMUM BEHIND TOP BACK OF CURB / GUTTER OR SIDEWALK.

 PARK CITY MUNICIPAL CORPORATION WATER	DATE	<h2>AIR VENT STAND PIPE</h2>	STD. PLAN
	3/2014		<h1>576</h1>
	REV.		
	0		

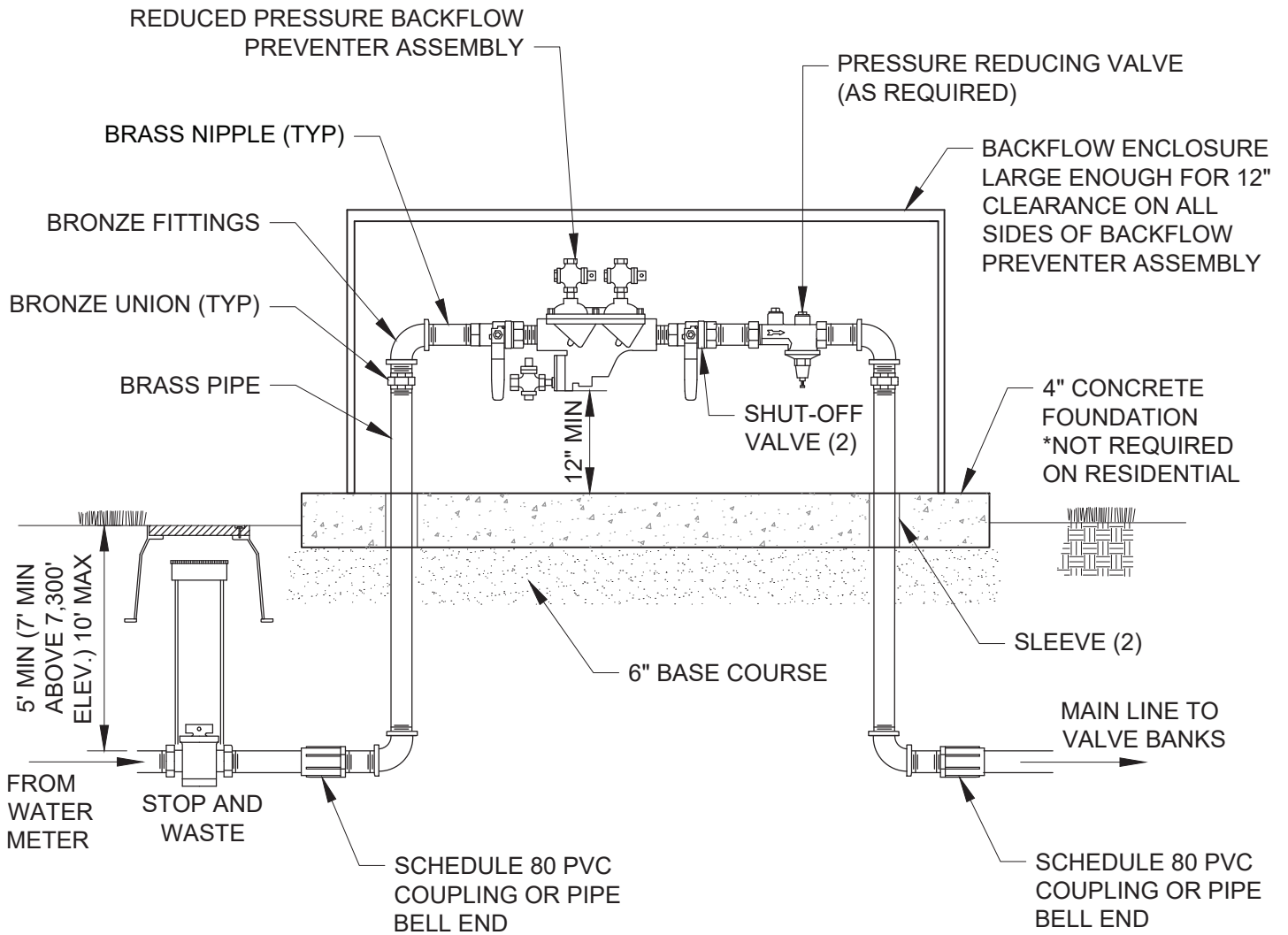

LESS THAN 3" DIAMETER



PARK CITY MUNICIPAL CORPORATION
WATER

DATE

03/2024

REV.

2

**CULINARY WATER - IRRIGATION
BACKFLOW PREVENTER**

STD. PLAN

577-A

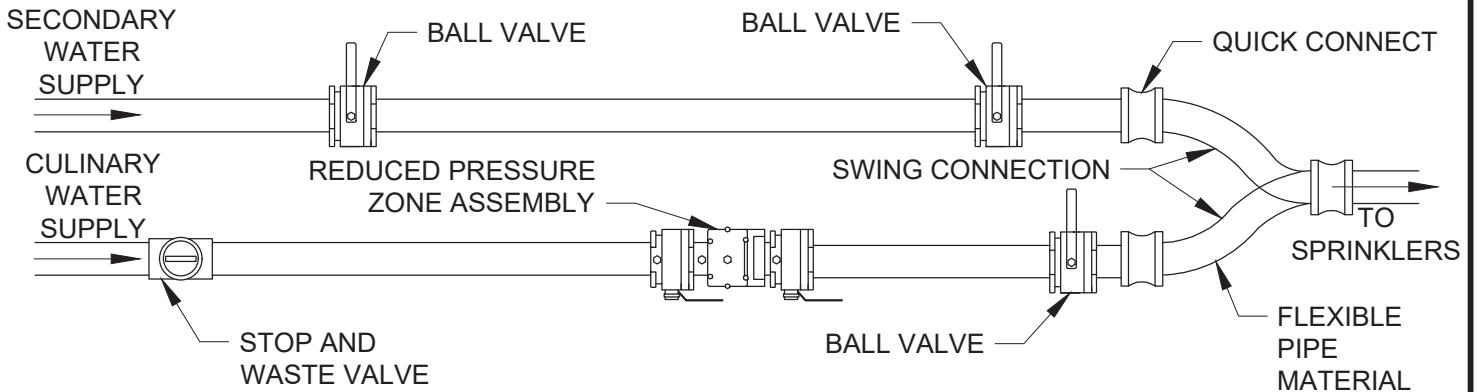

PLAN VIEW
NTS

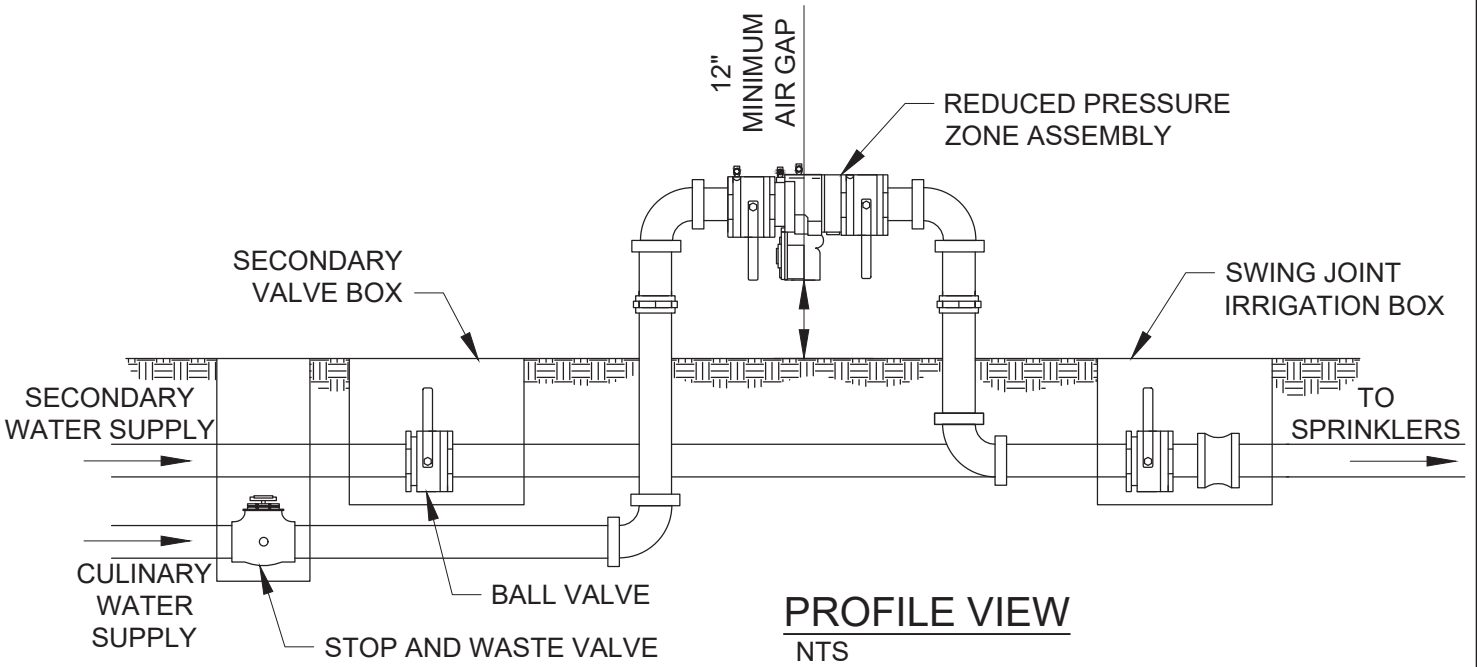

PROFILE VIEW
NTS

NOTES:

1. THE SWING CONNECTION IS INSTALLED SO THAT EITHER THE SECONDARY IRRIGATION WATER OR THE CULINARY WATER IS CONNECTED AND FEEDING THE SPRINKLER SYSTEM AT THE ONE TIME.
2. THE REDUCED PRESSURE ZONE ASSEMBLY MUST BE LOCATED AT A MINIMUM OF 12" FROM WALL, FENCE OR OTHER OBSTACLE.
3. THE REDUCED PRESSURE ZONE ASSEMBLY MUST BE LOCATED AT A MINIMUM OF 12" ABOVE GRADE (NOT ALLOWED IN A PIT BELOW GRADE).
4. THE REDUCED PRESSURE ZONE ASSEMBLY MUST BE INSPECTED BY A CERTIFIED BACKFLOW TECHNICIAN ON AN ANNUAL BASIS. CONSISTENT WITH PARK CITY MUNICIPAL CODE 13-1-29, BACKFLOW PREVENTER SHALL BE TESTED UPON INITIAL INSTALLATION AND EVERY 12 MONTHS THEREAFTER. PROOF OF TESTING/INSPECTION MUST BE PROVIDED TO PARK CITY EACH TIME. FAILURE TO PROVIDE PROOF OF TESTING MAY LEAD TO WATER SHUT-OFF TO PROTECT THE DRINKING WATER SYSTEM FROM POTENTIAL CONTAMINATION.

 PARK CITY MUNICIPAL CORPORATION WATER	DATE	CULINARY & SECONDARY WATER - IRRIGATION SWING CHECK CONNECTION	STD. PLAN
	03/2024		577-B
	REV.		
	0		

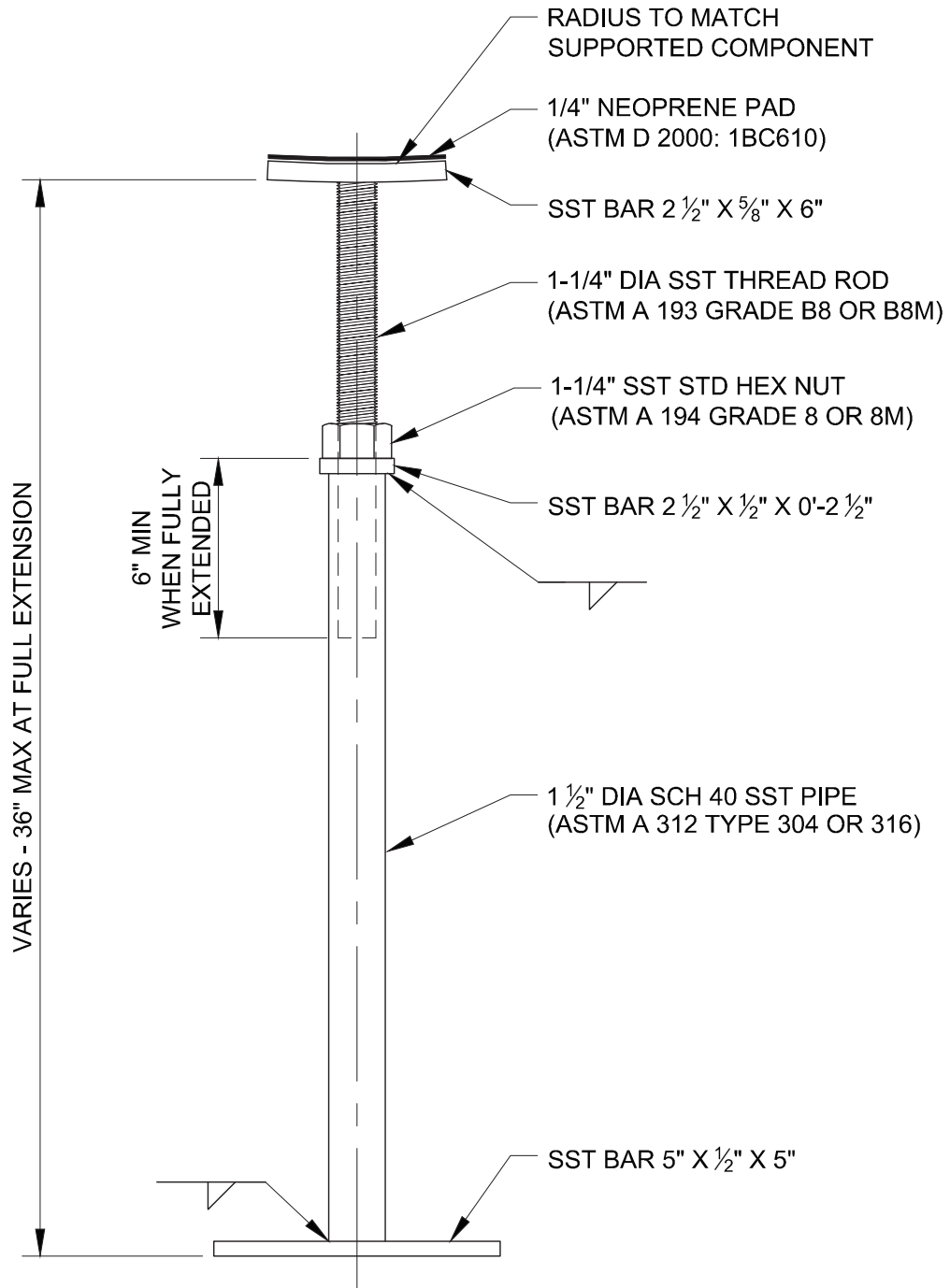

NOTES:

1. BAR MATERIAL TO BE ASTM A 240 TYPE 304 OR 316 (Fy= 30 KSI MIN.)

 PARK CITY MUNICIPAL CORPORATION WATER	DATE	<h2>PIPE SUPPORT</h2>	STD. PLAN
	3/2014		<h1>578</h1>
	REV.		
	0		

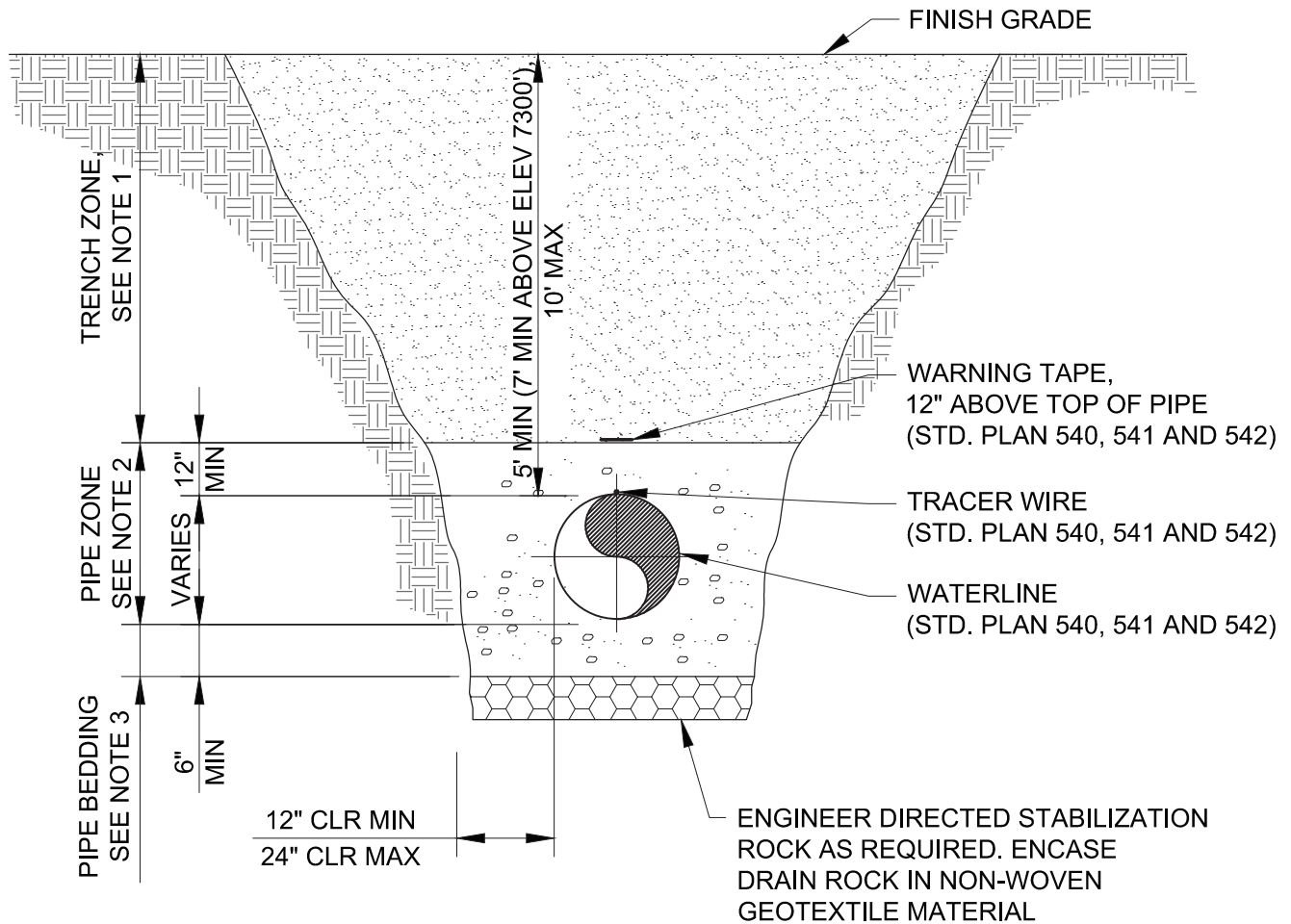

NOTES:

1. **TRENCH ZONE**
 WATER MAIN, FIRE LINE, AND APPURTENANCES:
 BACKFILL AND COMPACT PER PCMC DESIGN STANDARDS AND CONSTRUCTION SPECIFICATIONS UNLESS OTHERWISE REQUIRED BY SPECIAL CONDITIONS
 WATER SERVICE - NEW PAVEMENT AND LANDSCAPE AREA:
 BACKFILL AND COMPACT PER PCMC DESIGN STANDARDS AND CONSTRUCTION SPECIFICATIONS UNLESS OTHERWISE REQUIRED BY SPECIAL CONDITIONS
 WATER SERVICE - EXISTING ROADWAY AND PAVED AREA:
 BACKFILL TO PAVEMENT DEPTH WITH CONTROLLED LOW-STRENGTH MATERIAL (CLSM), "FLOWABLE FILL", 100 PSI MINIMUM AND 150 PSI MAXIMUM MIX DESIGN.
2. **PIPE ZONE**
 BACKFILL MATERIAL SHALL BE TAMPED IN LAYERS AROUND THE PIPE AND TO A SUFFICIENT HEIGHT ABOVE THE PIPE TO ADEQUATELY SUPPORT AND PROTECT THE PIPE. THE MATERIAL AND BACKFILL ZONES SHALL BE AS SPECIFIED BY THE APPLICABLE AWWA STANDARD FOR THAT PIPE TYPE. DO NOT DROP PIPE OR ACCESSORIES INTO THE TRENCH. AS A MINIMUM:
 WATER MAIN, FIRE LINE, AND APPURTENANCES:
 SAND OR 3/4" MAXIMUM PARTICLE SIZE ROADBASE COMPACT TO 96% OF MODIFIED PROCTOR DENSITY
 WATER SERVICE:
 SAND COMPACTED TO 96% OF MODIFIED PROCTOR DENSITY
3. **PIPE BEDDING**
 WATER MAIN, FIRE LINE, AND APPURTENANCES:
 SAND OR 3/4" ROADBASE COMPACT TO 96% OF MODIFIED PROCTOR DENSITY
 WATER SERVICE:
 SAND COMPACTED TO 96% OF MODIFIED PROCTOR DENSITY
 A CONTINUOUS AND UNIFORM BEDDING SHALL BE PROVIDED IN THE TRENCH FOR ALL BURIED PIPE. STONES LARGER THAN 3/4" AS DESCRIBED IN NOTE 2 SHALL BE REMOVED FOR A DEPTH OF AT LEAST 6 INCHES BELOW THE BOTTOM OF THE PIPE.
4. PROVIDE TRENCH PLATING AS REQUIRED FOR CLSM BACKFILL INSTALLATIONS
5. COMPLY WITH APPLICABLE PARK CITY SOILS ORDINANCE REQUIREMENTS

 PARK CITY MUNICIPAL CORPORATION WATER	DATE	WATER TRENCH BEDDING AND BACKFILL	STD. PLAN
	6/2019		580
	REV.		
	1		

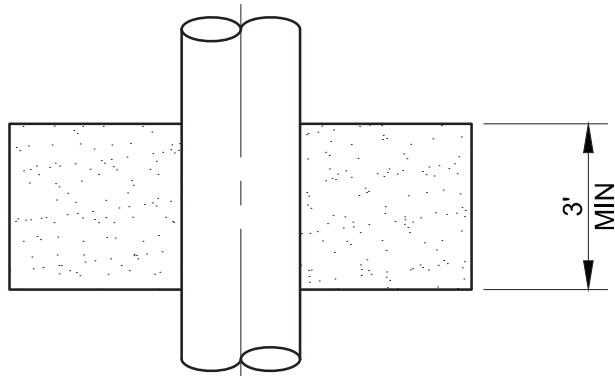

PLAN
NTS

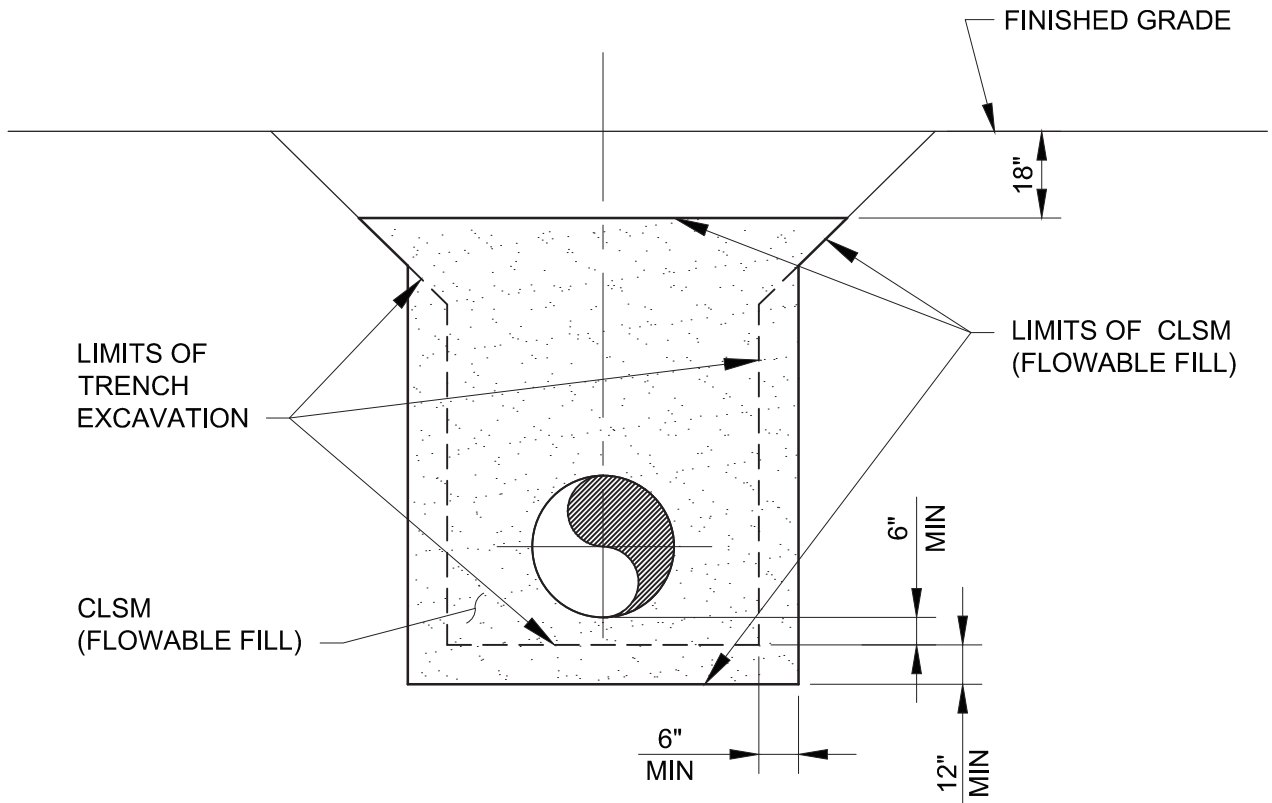

SECTION
NTS

NOTES:

1. CLSM - CONTROLLED LOW STRENGTH MATERIAL, DESIGN MIX 100-150 PSI



PARK CITY MUNICIPAL CORPORATION
WATER

DATE

3/2014

REV.

0

**WATER TRENCH
CUT-OFF WALL**

STD. PLAN

581

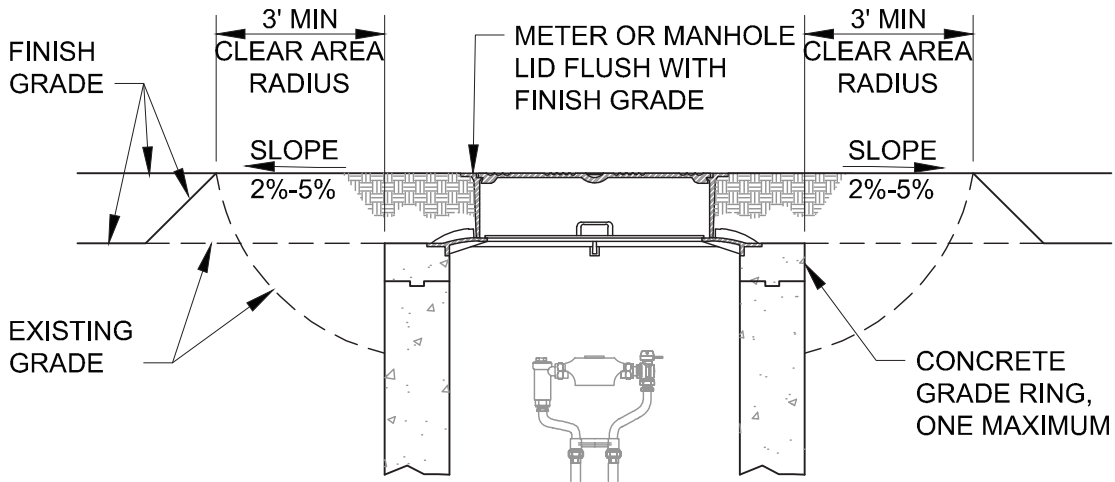

LOW/HIGH GRADE ADJUSTMENT

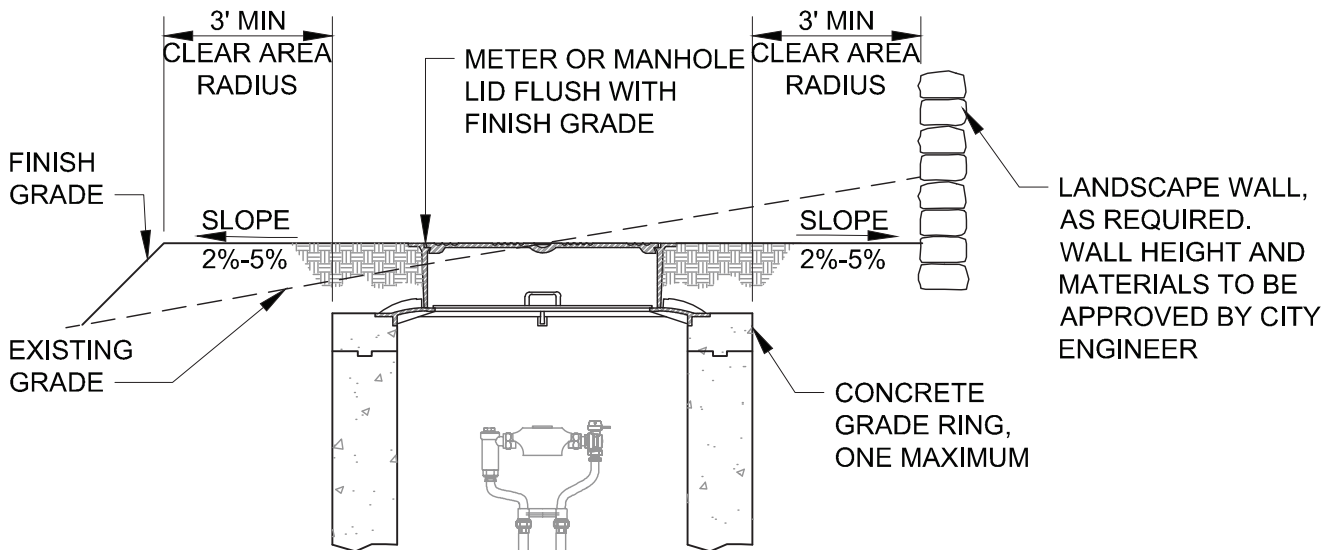

SLOPE GRADE ADJUSTMENT

NOTES:

1. REFER TO STD. PLAN 520 FOR GENERAL REQUIREMENTS - METER, METER VAULT, AND SERVICE LINE.
2. METER YOKE DEPTH MUST MEET THE METER VAULT REQUIREMENTS. (PLAN 521 THRU 525)
3. METER LID HIGHER THAN THE SURROUNDING FINISH GRADE:
RAISE GRADE SURROUNDING METER LID TO THE TOP OF METER LID.
PROVIDE DRAINAGE AWAY FROM THE METER LID.
4. METER LID LOWER THAN THE SURROUNDING FINISH GRADE:
RAISE METER VAULT AND COMPONENTS TO MEET METER VAULT REQUIREMENTS.

 PARK CITY MUNICIPAL CORPORATION WATER	DATE	METER VAULT AND WATER MANHOLE GRADING LANDSCAPE AREAS	STD. PLAN	
			3/2014	592
	REV.		0	
			0	

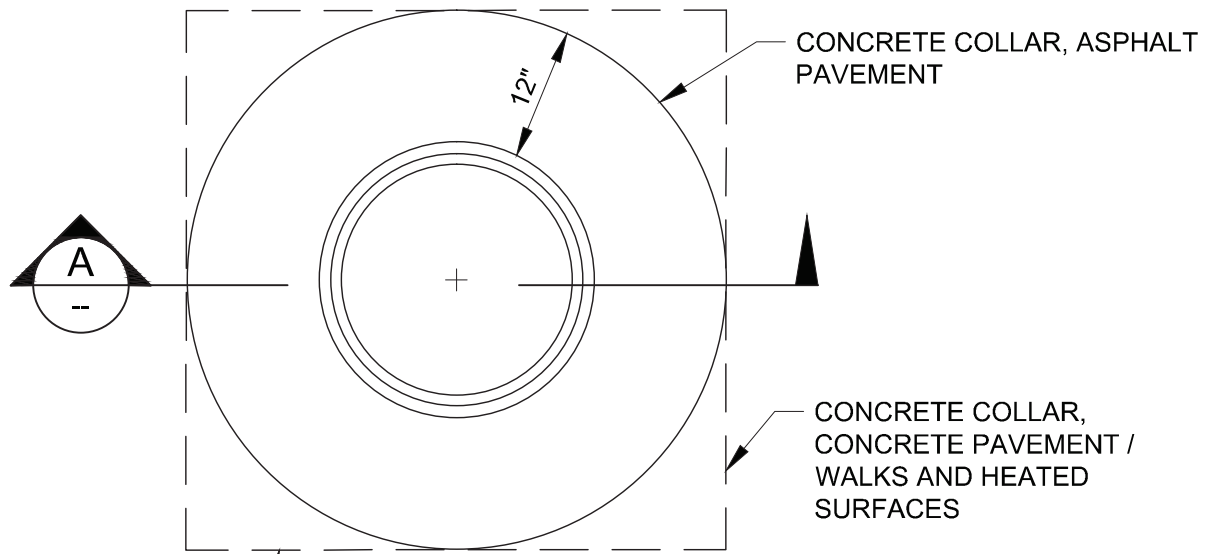

PROVIDE HEATING SYSTEM DISCONNECT AT COLLAR LIMITS. 24" COLLAR REQUIRED FOR 4' AND 5' MANHOLES AND VAULTS

ASPHALT PAVEMENT:
COLLAR SET $\frac{1}{4}$ " MIN. TO $\frac{1}{2}$ " MAX. BELOW PAVEMENT LIP ALL AROUND.

CONCRETE PAVEMENT:
SET COLLAR FLUSH WITH PAVEMENT LIP

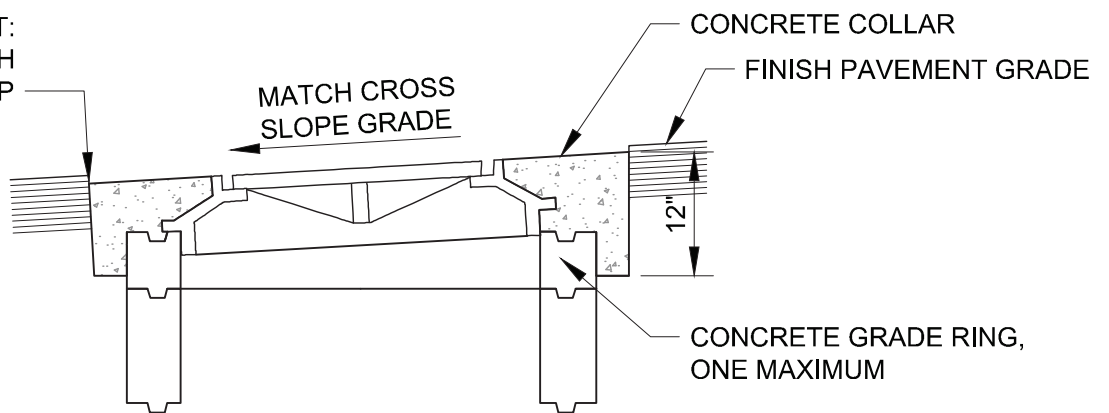

SECTION
NTS

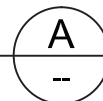

PARK CITY MUNICIPAL CORPORATION
WATER

DATE

3/2014

REV.

0

**METER VAULT AND
WATER MANHOLE COLLAR
PAVEMENT AREAS**

STD. PLAN

593

1 WATER SERVICE LINE FLOW CHART

SYSTEM PRESSURE (PSI)	2 MIN. SYSTEM RESIDUAL FIRE FLOW PRESSURE (PSI)	AVAILABLE PRESSURE DROP (PSI)	SERVICE SIZE (INCH)							
			0.75		1		1.5		2	
			AVAILABLE FLOW WITHOUT METER (GPM)	* RATED FLOW THROUGH METER (GPM)	AVAILABLE FLOW WITHOUT METER (GPM)	* RATED FLOW THROUGH METER (GPM)	AVAILABLE FLOW WITHOUT METER (GPM)	* RATED FLOW THROUGH METER (GPM)	AVAILABLE FLOW WITHOUT METER (GPM)	* RATED FLOW THROUGH METER (GPM)
150	20	130	53	30	113	50	328	100	700	160
145	20	125	52	30	111	50	322	100	686	160
140	20	120	51	30	108	50	315	100	671	160
135	20	115	50	30	106	50	307	100	655	160
130	20	110	48	30	103	50	300	100	640	160
125	20	105	47	30	101	50	293	100	624	160
120	20	100	46	30	98	50	285	100	608	160
115	20	95	45	30	95	50	277	100	591	160
110	20	90	43	30	93	50	269	100	574	160
105	20	85	42	30	90	50	261	100	557	160
100	20	80	41	30	87	50	253	100	539	160
95	20	75	39	30	84	50	244	100	520	160
90	20	70	38	30	81	50	235	100	501	160
85	20	65	36	30	78	50	226	100	482	160
80	20	60	35	30	74	50	216	100	461	160
75	20	55	33	30	71	50	206	100	440	160
70	20	50	32	28	67	50	196	100	418	160
65	20	45	30	26	64	50	185	100	395	160
60	20	40	28	24	60	50	174	100	370	160
55	20	35	26	23	56	48	162	100	345	160
50	20	30	24	21	51	44	149	100	317	160
45	20	25	22	19	46	40	135	100	287	160
40	20	20	19	17	41	36	119	88	255	158
35	20	15	16	14	35	30	102	76	218	135
30	20	10	13	12	28	24	82	62	175	110
25	20	5	9	8	19	17	56	43	120	77
20	20	0	0	0	0	0	0	0	0	0

NOTES:

1. WATER SERVICE LINE DESIGN IS NOT TO EXCEED 10FPS IN FIRE FLOW SITUATIONS
2. REFER TO STD. PLAN 594.2 FOR NOTES AND REFERENCES.

 PARK CITY MUNICIPAL CORPORATION WATER	DATE	<h2 style="margin: 0;">WATER SERVICE LINE FLOW CHART</h2>	STD. PLAN
	03/2024		<h1 style="margin: 0;">594.1</h1>
	REV.		
	1		

* VALUES DERIVED FROM SR WATER METERS TYPICAL PERFORMANCE CURVES AND THE METERS AWWA MAXIMUM CAPACITY

ASSUMED:

L (FT) = 40.0 (MAX LENGTH IN FEET FROM MAIN TO METER)

C = 135.0 (OLDER HDPE PIPE)

WHEN USED TO CALCULATE THE PRESSURE DROP USING THE US CUSTOMARY UNITS SYSTEM, THE EQUATION IS:

$$P_d = \frac{4.52 * L * Q^{1.85}}{C^{1.85} * d^{4.87}}$$

WHERE:

P_D = PRESSURE DROP OVER A LENGTH OF PIPE, PSIG (POUNDS PER SQUARE INCH GAUGE PRESSURE)

L = LENGTH OF PIPE, FT (FEET)

Q = FLOW, GPM (GALLONS PER MINUTE)

d = INSIDE PIPE DIAMETER, IN (INCHES)

C = HAZEN WILLIAMS COEFFICIENT OF FRICTION

NOTES:

1. THIS TABLE IS FOR REFERENCE PURPOSES ONLY AND REPRESENTS MAXIMUM ANTICIPATED FLOW TO THE POINT OF CONNECTION (40 FOOT MAXIMUM LENGTH) WITHOUT ADDITIONAL VALVES AND PIPING. HOMEOWNERS, ARCHITECTS, ENGINEERS, FIRE SPRINKLER DESIGNERS, ETC., ARE RESPONSIBLE TO VERIFY EXISTING WATER SYSTEM PRESSURES PRIOR TO DESIGN AND INCORPORATE THE INFORMATION INTO THE WATER SERVICE AND FIRE SERVICE LINE DESIGN. ADDITIONAL PRESSURE LOSSES WILL OCCUR THROUGH ADDITIONAL REQUIRED VALVES AND PIPING.
2. THE MINIMUM WATER PRESSURE AT THE POINT OF CONNECTION SHALL BE ABOVE 20 PSI WITH FIRE FLOW AND PEAK DAY DEMANDS, ABOVE 30 PSI WITH PEAK INSTANTANEOUS DEMANDS, AND ABOVE 40 PSI WITH PEAK DAY DEMANDS. SEE UTAH ADMINISTRATIVE CODE R309-105-9. MINIMUM WATER PRESSURE.
3. INDIVIDUAL HOME BOOSTER PUMPS SHALL NOT BE ALLOWED FOR ANY INDIVIDUAL SERVICE FROM THE PUBLIC WATER SUPPLY MAIN, SEE UTAH ADMINISTRATIVE CODE R309-105-9 AND R309-540-5(4)(C)

 PARK CITY MUNICIPAL CORPORATION WATER	DATE	WATER SERVICE LINE FLOW CHART	STD. PLAN
	4/2014		594.2
	REV.		
	0		

DOUBLE CHECK VALVE OR REDUCED PRESSURE PRINCIPLE BACKFLOW PREVENTER (SEE NOTES 2 AND 3)

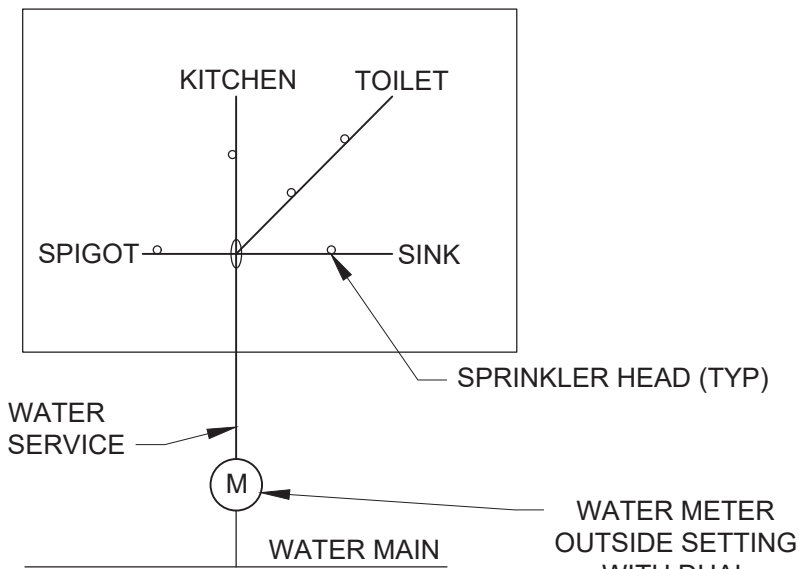

OPTION 1

MULTI-PURPOSE PIPING SYSTEM (SEE NOTE 2)

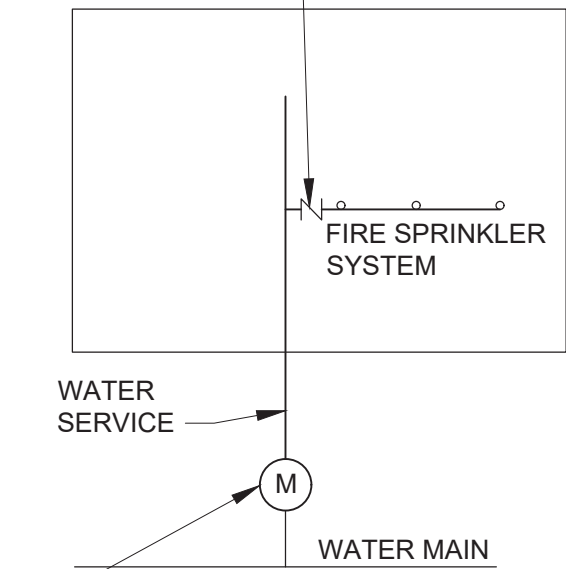

OPTION 2

BRANCHED

NOTES:

1. MULTI-PURPOSE RESIDENTIAL FIRE SPRINKLER PROTECTION PLUMBING SYSTEM SHALL MEET NFPA 13D OR 13R REQUIREMENTS AND PARK CITY BUILDING DEPARTMENT AND FIRE MARSHAL APPROVAL. OPTION 1 SHALL BE APPROVED BY THE PARK CITY BUILDING DEPARTMENT, CITY ENGINEER, AND FIRE MARSHAL PRIOR TO SYSTEM DESIGN. ALL SPRINKLERS AND SYSTEM COMPONENTS SHALL BE NSF LISTED FOR POTABLE WATER. ALL PIPE SHALL BE LISTED FOR FIRE PROTECTION SERVICE.
2. DESIGN AND CONSTRUCTION SHALL COMPLY WITH INTERNATIONAL PLUMBING CODE (IPC) AS ADOPTED BY UTAH, AND WITH APPLICABLE RESIDENTIAL AND BUILDING CODES.
3. BACKFLOW PREVENTION: ADDITIONAL BACKFLOW PREVENTION IS REQUIRED FOR OPTION 2. PROVIDE A DOUBLE CHECK BACKFLOW ASSEMBLY (DC) OR REDUCED PRESSURE PRINCIPLE BACKFLOW ASSEMBLY (RP) ON THE FIRE SPRINKLER RISER ASSEMBLY. BACKFLOW PREVENTER STYLE TO BE DETERMINED BY IPC AS ADOPTED BY UTAH AND APPROVED BY THE BUILDING AND WATER DEPARTMENT BASED ON DEGREE OF HAZARD POSED BY FIRE SPRINKLER PROTECTION SYSTEM.
4. BEFORE A CERTIFICATE OF OCCUPANCY CAN BE ISSUED BY THE BUILDING DEPARTMENT, BACKFLOW ASSEMBLY TESTING FOR PROPER OPERATION (PER IPC AS ADOPTED BY UTAH BY A CERTIFIED TESTER RECOGNIZED BY THE UTAH DIVISION OF DRINKING WATER [DDW]) IS REQUIRED AND A REPORT MUST BE SUBMITTED TO THE CITY.
5. FIRE SPRINKLER PROTECTION SYSTEMS CONTAINING FIRE PUMPS REQUIRE SITE SPECIFIC DESIGN AND APPROVAL BY THE CITY ENGINEER, PARK CITY BUILDING DEPARTMENT, WATER DEPARTMENT, AND FIRE MARSHAL PRIOR TO BUILDING APPROVAL. FIRE PUMP SYSTEM SHALL BE LOCATED ON THE BUILDING SIDE OF THE WATER OUTSIDE OF THE WATER METER VAULT. REFER TO STD. PLAN 520 FOR REQUIREMENTS.

 PARK CITY MUNICIPAL CORPORATION WATER	DATE	NFPA 13D OR 13R RESIDENTIAL FIRE SPRINKLER SERVICES	STD. PLAN
	03/2024		595
	REV.		
	1		

DETAIL NOTES

1. REFER TO STD. PLAN 520 FOR GENERAL REQUIREMENTS – METER, METER VAULT, AND SERVICE LINE
2. REFER TO STD. PLANS FOR WATER SERVICE REQUIREMENTS
3. REFER TO THE STATE OF UTAH, DEPARTMENT OF ENVIRONMENTAL QUALITY DIVISION OF DRINKING WATER LIST OF APPROVED BACKFLOW PREVENTION DEVICES. APPROVED DEVICES CAN BE FOUND ON THE UTAH DIVISION OF DRINKING WATER (DDW), CROSS CONNECTION CONTROL & BACKFLOW PREVENTION WEBSITE:
4. BACKFLOW ASSEMBLY SELECTION AND INSTALLATION SHALL CONFORM TO THE APPROVED INSTALLATION ORIENTATION ONLY.
5. ALL BACKFLOW PREVENTION DEVICES USED WITHIN THE STATE OF UTAH SHALL HAVE THIRD PARTY CERTIFICATION AS MENTIONED ABOVE.
6. ALL BACKFLOW PREVENTERS HAVE TO BE TESTED ANNUALLY TO ENSURE THAT THEY ARE FUNCTIONING PROPERLY. A VISUAL CHECK OF AIR GAPS IS SUFFICIENT, BUT MECHANICAL BACKFLOW PREVENTERS HAVE TO BE TESTED BY A STATE CERTIFIED BACKFLOW SPECIALIST, WITH PROPERLY CALIBRATED GAUGE EQUIPMENT. TO OBTAIN A LIST OF STATE CERTIFIED TESTERS REFER TO THE UTAH DIVISION OF DRINKING WATER (DDW), CROSS CONNECTION CONTROL & BACKFLOW PREVENTION WEBSITE.
7. FIRE SPRINKLER SYSTEM PUMPS, INTEGRAL TO THE FIRE SPRINKLER PIPING, TO MEET FIRE SPRINKLER PRESSURE DESIGN REQUIREMENTS ARE CONSIDERED OUTSIDE THE INTENT OF UTAH DDW REGULATION R309-550-11(3) AND DO NOT REQUIRE APPROVAL OF THE DDW IF THEIR INSTALLATION CONFORMS TO UTAH ADOPTED PLUMBING CODE AND NATIONAL FIRE PROTECTION ASSOCIATION (NFPA) 13 D. PUMPS SHALL BE CONNECTED ON THE BUILDING SIDE OF THE WATER METER VAULT AND SHALL BE APPROVED BY THE CITY ENGINEER AND BUILDING DEPARTMENT. PUMP APPROVAL IS FOR FIRE SPRINKLER SYSTEMS ONLY AND NOT FOR DOMESTIC USE.

 PARK CITY <small>1884</small> PARK CITY MUNICIPAL CORPORATION WATER	DATE	NFPA 13D OR 13R RESIDENTIAL FIRE SPRINKLER SERVICES	STD. PLAN
	3/2024		595 S
	REV.		
	1		

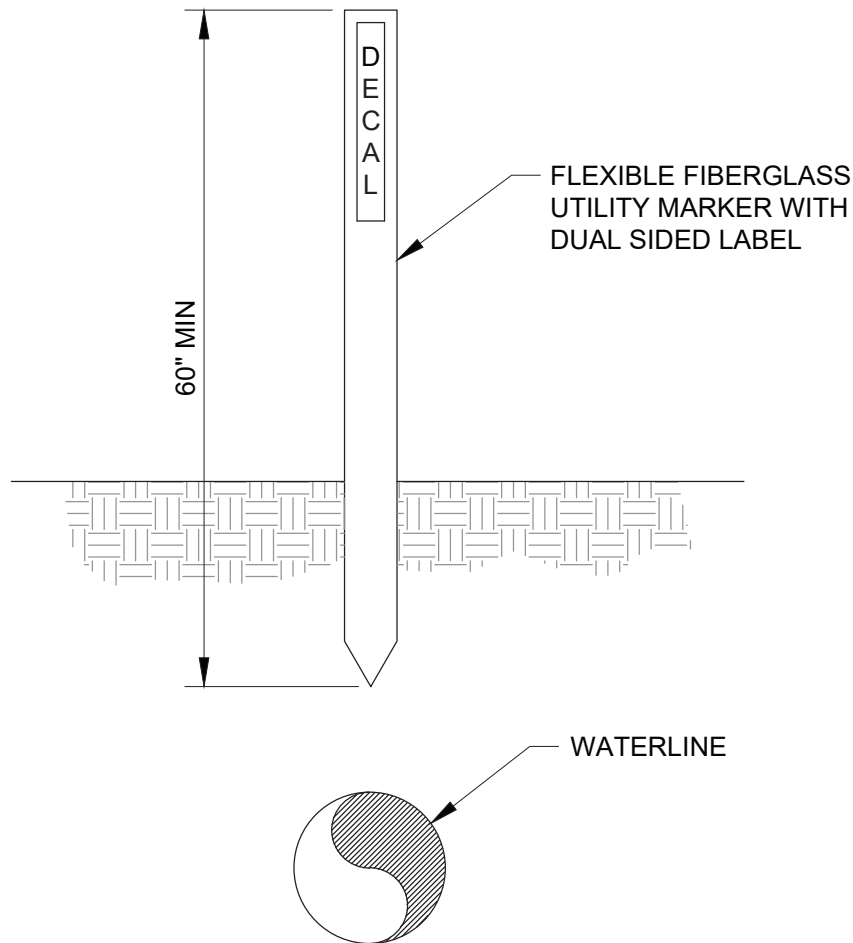

NOTES:

1. INSTALL REFERENCE POST WHEN WATERLINE IS LOCATED OUTSIDE OF PUBLIC RIGHT-OF-WAYS WHEN DIRECTED BY CITY ENGINEER AND WATER DEPARTMENT.
2. BURIED WATER LINE MARKER SHALL BE CONSTRUCTED ON 4" RHINO 3-RAIL FIBERGLASS UTILITY MARKER POSTS WITH VERBIAGE AS SHOWN ON THIS DETAIL. BY "RHINO" OR EQUAL. (WWW.RHINOMARKERS.COM)
3. PARK CITY LOGO IS WHITE PMS CL GY, 5CCV, 282CV AND 180CV. ALL TEXT AND GRAPHICS SHALL BE SET AGAINST A WHITE BACKGROUND. (RHINO MARKERS SHALL REFER TO SD-7964K DECAL)
4. MOUNT MARKERS PER MANUFACTURERS RECOMMENDATIONS.
5. INSTALL MARKERS AT LOCATIONS INDICATED ON PLANS BUT TYPICALLY EVERY 500 FT AND AT VALVES, TRACER WIRE BOXES, AND BENDS IN ALIGNMENT.
6. PLACE MARKER ON PIPE CENTERLINE.
7. OBTAIN LOGOS FROM PARK CITY TO PROVIDE TO SIGN MANUFACTURER.
8. PRINTING MATERIAL AND SIGN MATERIAL SHALL BE WATER-RESISTANT.
9. LABEL TO READ "CAUTION WATER PIPELINE - BEFORE DIGGING CALL 811"

 PARK CITY MUNICIPAL CORPORATION WATER	DATE	WATERLINE REFERENCE MARKER	STD. PLAN
	3/2014		596
	REV.		
	0		

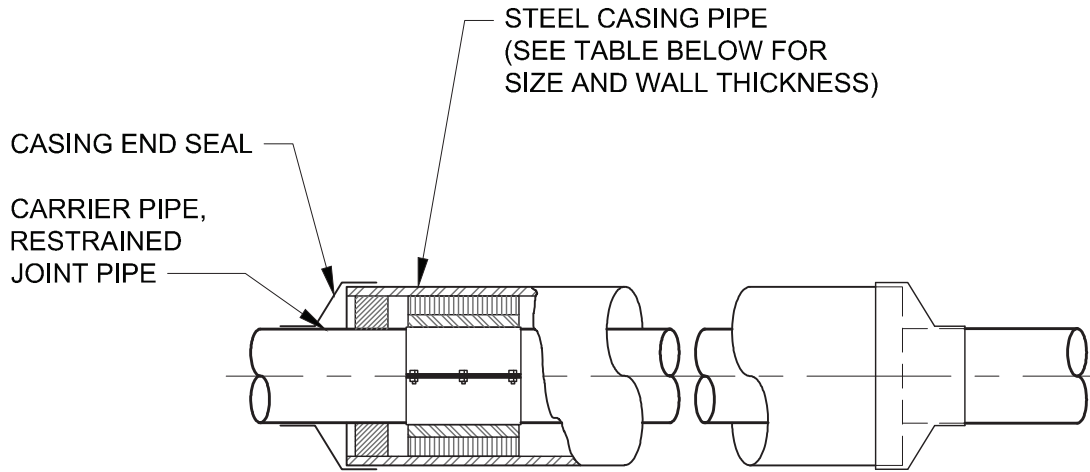

SLED

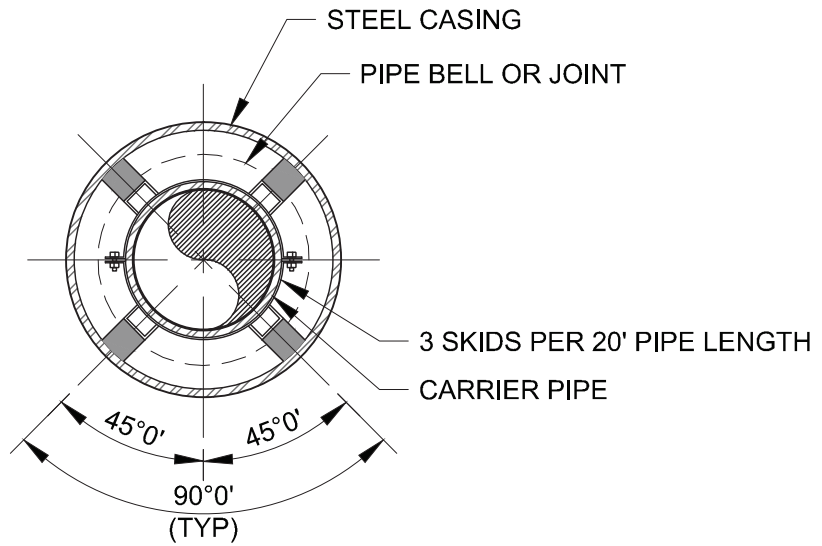

PIPE CASING

CARRIER PIPE NOMINAL DIAMETER	CASING PIPE	
	MIN OD	MIN WALL THICKNESS
4"	12"	0.25"
6"	16"	0.3125"
8"	18"	0.3125"
12"	22"	0.375"
16"	28"	0.50"
20"	32"	0.50"



PARK CITY MUNICIPAL CORPORATION
WATER

DATE

4/2014

REV.

0

WATERLINE CASING

STD. PLAN

597

LEGEND AND APPROVED PARTS LIST

ITEM	DESCRIPTION	ACCEPTABLE MANUFACTURER	MODELS
①	CASING END SEAL	PIPELINE SEAL AND INSULATOR, INC	MODEL "S"
②	CASING SPACER	PIPELINE SEAL AND INSULATOR, INC.	C12G-2 OR APPROVED EQUAL
③	CARRIER PIPE: DUCTILE IRON RESTRAINED JOINT (STD. PLAN 540)		

DETAIL NOTES

1. PROVIDE CARRIER AND CASING SIZE, LOCATION, AND DEPTH PER APPROVED PLANS
2. INSTALL MECHANICAL JOINT A MAXIMUM OF 18" FROM EACH END OF CASING
3. IF REQUIRED BY APPROVED PLANS, INSTALL CLOSED CELL INSULATION IN ANNULAR SPACE BETWEEN CARRIER PIPE AND CASING. INSTALLATION METHOD TO BE APPROVED BY CITY.

 PARK CITY MUNICIPAL CORPORATION WATER	DATE	WATERLINE CASING	STD. PLAN
	4/2014		597 S
	REV.		
	0		

DIVISION 600-800 UNUSED

DIVISION 900 INFORMATION TECHNOLOGY SYSTEMS

900.01 Information Technology System Standards

PART 1 GENERAL

1.1 SECTION INCLUDES

- A. Park City has adopted the current Utah Department of Transportation (UDOT) Standard Specifications and Standard Drawings sections 13431 through 13595 regarding Information Technology System (ITS) Standards with the following exceptions. Applicants shall comply with these UDOT Standards and Specifications unless given written exception by the City Manager or Designee.

1.2 UDOT STANDARD DRAWING EXCEPTIONS

- A. Amend the following standard drawings:
The amendments are shown in the drawings with a “9-” prefix as provided in section 900.02 ITS Supplemental Standard Drawings.
 - AT 6 Conduit Details
 - AT 7A Polymer Concrete Junction Box Details
 - AT 7B Precast Concrete Fiber Optic and Utility Vault Details
 - AT-8 ITS Cabinet
 - AT-9 ITS Cabinet and Equipment Disconnect and Transformer Frame

1.3 UDOT ITS DESIGN MANUAL

- A. Park City has adopted the current Utah Department of Transportation (UDOT) ITS Design Manual as the guiding directions for connection to the city infrastructure. Applicants shall comply with these guidelines in coordination with Park City IT unless given written exception by the City Manager or Designee.

PART 2 PRODUCTS

Not Used

PART 3 EXECUTION

Not Used

END OF SECTION

900.02 Information Technology System Drawings

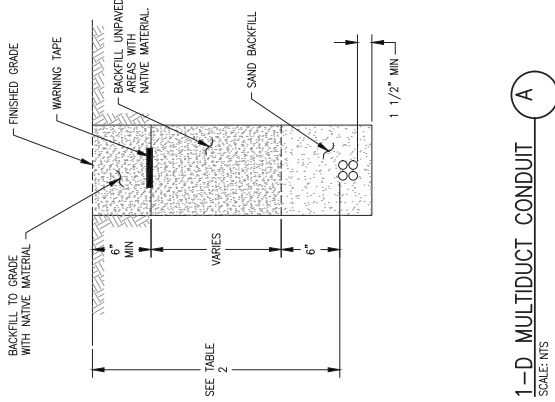

1-D MULTIDUCT CONDUIT
 SCALE: NTS
 (A)

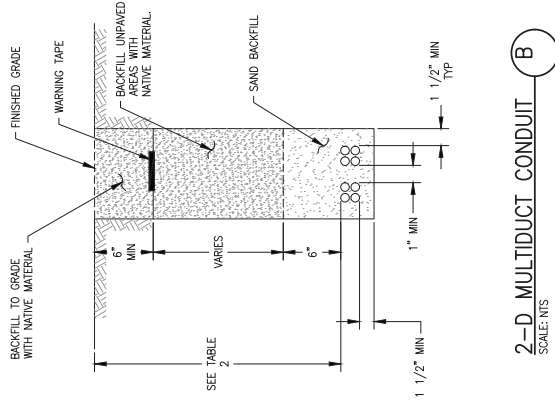

2-D MULTIDUCT CONDUIT
 SCALE: NTS
 (B)

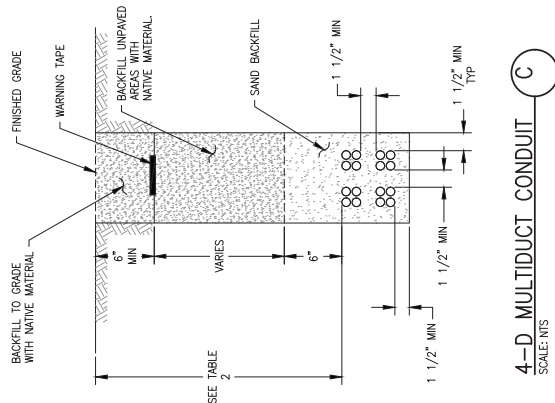

4-D MULTIDUCT CONDUIT
 SCALE: NTS
 (C)

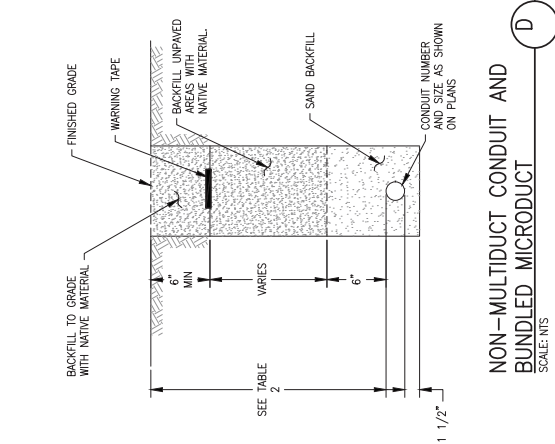

NON-MULTIDUCT CONDUIT AND BUNDLED MICRODUCT
 SCALE: NTS
 (D)

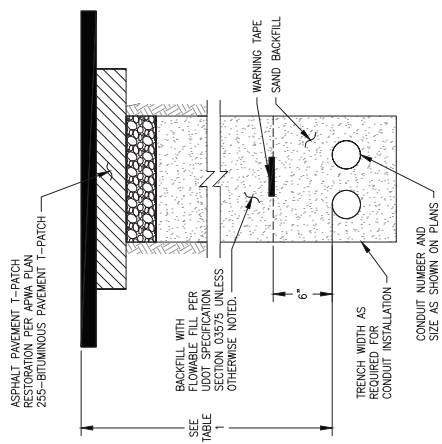

CONDUIT TRENCHED IN ASPHALT PAVEMENT RESTORED WITH T-PATCH
 SCALE: NTS
 (E)

TABLE 1. MINIMUM CONDUIT DEPTH

DEPTH IN INCHES	AREA
A	NATIVE OR LANDSCAPED AREA
B	CONCRETE PAVED AREA (NON-ROADWAY)
C	WITHIN STREET/ROADWAY

DEVIATION FROM TABLE 1 MINIMUM CONDUIT DEPTHS WILL BE CONSIDERED ON A CASE-BY CASE BASIS AND REQUIRE WRITTEN APPROVAL FROM PARK CITY MUNICIPAL ENGINEERING.

NOTES:

1. USE SAND BACKFILL AND FLOWABLE FILL WITHIN EXISTING ROADWAY, PROPOSED ROADWAY AND SIDEWALK PAVEMENT AREAS ONLY.
2. INSTALL DETECTABLE PULL TAPE IN ALL EMPTY CONDUITS.
3. USE 3/8 INCH MINUS WELL-GRADED SAND.
4. REFER TO THE FOLLOWING UDOT STANDARD SPECIFICATIONS FOR ADDITIONAL INFORMATION:
 - 13563 - ITS CONDUIT
 - 13584 - FIBER OPTIC COMMUNICATION
 - 13585 - ITS INTEGRATION, INSPECTION, TESTING, AND ACCEPTANCE

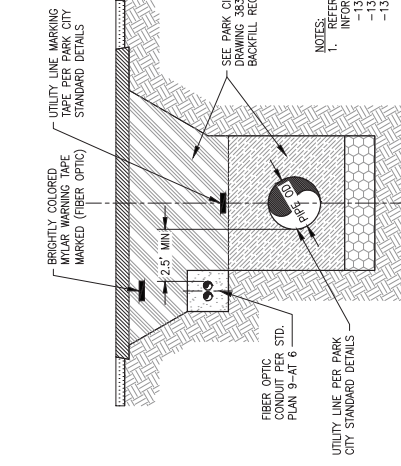

TYPICAL PLAN VIEW
 SCALE: NONE

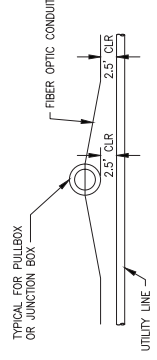

TYPICAL PLAN VIEW
 SCALE: NONE

- NOTES:
1. REFER TO THE FOLLOWING UDOT STANDARD SPECIFICATIONS FOR ADDITIONAL INFORMATION:
 - 13563 - ITS CONDUIT
 - 13584 - FIBER OPTIC COMMUNICATION
 - 13585 - ITS INTEGRATION, INSPECTION, TESTING, AND ACCEPTANCE

FIBER OPTIC CONDUIT IN COORDINATION WITH OTHER UTILITY INSTALLATION
 SCALE: NTS
 (F)

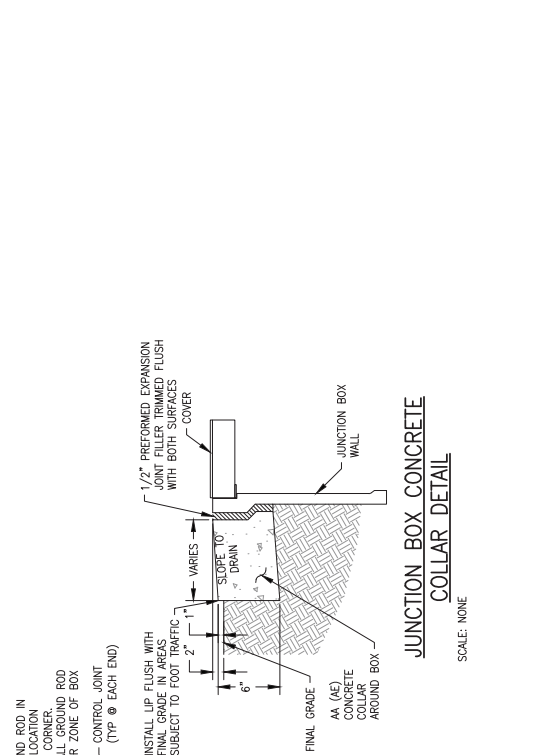
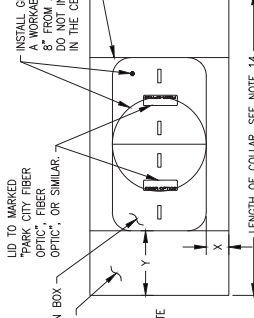

TABLE OF DIMENSIONS

BOX TYPE	W" INCH	H" INCH	X" INCH	Y" INCH	LOADING TIER
I-PC	13	24	24	10	TIER 22
II-PC	24	36	36	10	TIER 22
III-PC	30	48	36	10	TIER 22



JUNCTION BOX CONCRETE COLLAR DETAIL
 SCALE: NONE

- NOTES:
- BOX LOGO OR NAME PLATE, REFER TO UDOT STANDARD SPECIFICATION 13554.
 - DO NOT PLACE JUNCTION BOXES IN THE TRAVELED WAY OR ON FREEWAY SHOULDERS.
 - CONCRETE COLLAR WIDTH VARIES WHEN ADJACENT TO ATMS CABINETS, REFER TO UDOT AT AND SL SERIES STD DWGS.
 - PROVIDE CONCRETE COLLARS EXCEPT WITHIN CONCRETE PAVED AREAS, OR OTHERWISE NOTED ON DESIGN DRAWINGS.
 - INSTALL CONDUIT PLUG PER STANDARD SPECIFICATION 13554.
 - ALIGN ATMS CONDUIT BY COLOR ON EACH SIDE OF THE JUNCTION BOX.
 - PROVIDE TYPE III-PC JUNCTION BOXES WITH A SPLIT LID.
 - CONFORM TO ANSI/SCTE-77 "SPECIFICATION FOR UNDERGROUND ENCLOSURE INTEGRITY" TIER 22 LOADING FOR ALL JUNCTION BOXES. TIER 22 ID PLATE TO BE VISIBLE ON BOX.
 - EXTEND GROUND ROD A MINIMUM OF 4 INCHES AND A MAXIMUM OF 6 INCHES ABOVE BOTTOM OF JUNCTION BOX.
 - USE INTER SYSTEM GROUNDING BRIDGE CLAMP FOR BONDING TO GROUND ROD. ATTACH NOT MORE THAN 4 WIRES PER CLAMP.
 - DO NOT CUT GROUND RODS.
 - PROVIDE CLEAR SPACE OF AT LEAST 36 INCH FOR PERSONNEL TO PULL LID OFF BOX WITHOUT CONFLICT.
 - PLACE JUNCTION BOXES AND CONCRETE COLLARS LEVEL WITH GRADE ON SLOPES 6:1 OR FLATTER. REFER TO PLANS FOR DETAILS OF JUNCTION BOX PLACEMENTS ON SLOPES STEEPER THAN 6:1. SLOPE CONCRETE COLLAR TO DRAIN AS SHOWN.
 - INSTALL ENTIRE PAD UNIFORMLY TO LONGEST LENGTH WHEN SEVERAL JUNCTION BOXES ARE BEING PLACED ADJACENT TO ONE ANOTHER.
 - REFER TO THE FOLLOWING UDOT STANDARD SPECIFICATIONS FOR ADDITIONAL INFORMATION:
 -13553 - ITS CONDUIT
 -13554 - POLYMER CONCRETE JUNCTION BOX
 -13594 - FIBER OPTIC COMMUNICATION
 -13595 - ITS INTEGRATION, INSPECTION, TESTING, AND ACCEPTANCE

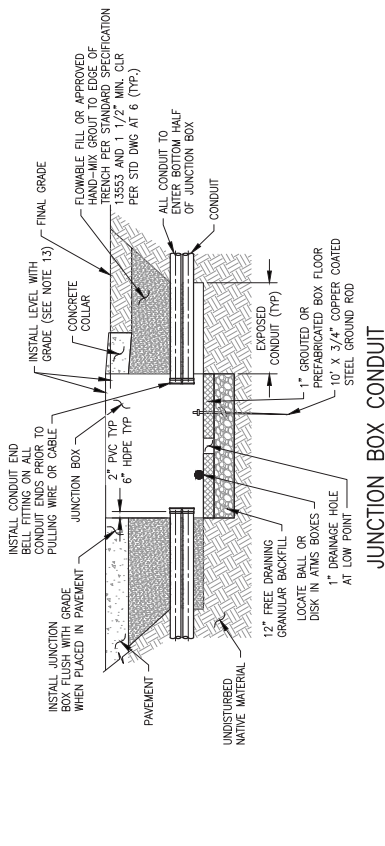
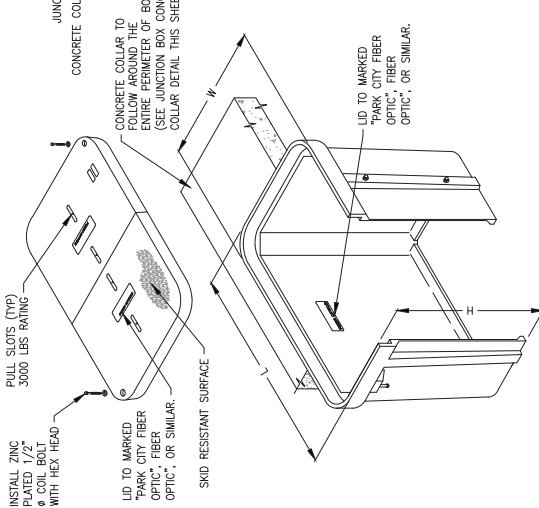

JUNCTION BOX CONDUIT PENETRATION DETAIL
 SCALE: NONE

PRECAST CONCRETE FIBER OPTIC AND UTILITY VAULT DETAILS

DATE	03/2024
REV.	

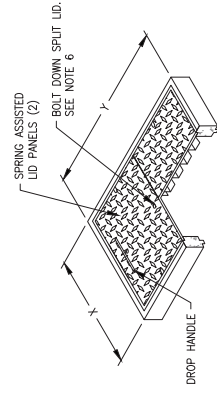

METAL LID FOR TYPE IV-CV FIBER VAULT
SCALE: NONE

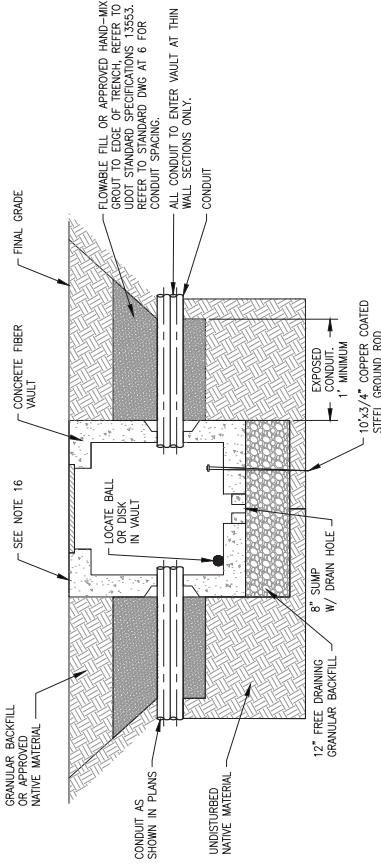

FIBER VAULT CONDUIT PENETRATION DETAIL
SCALE: NONE

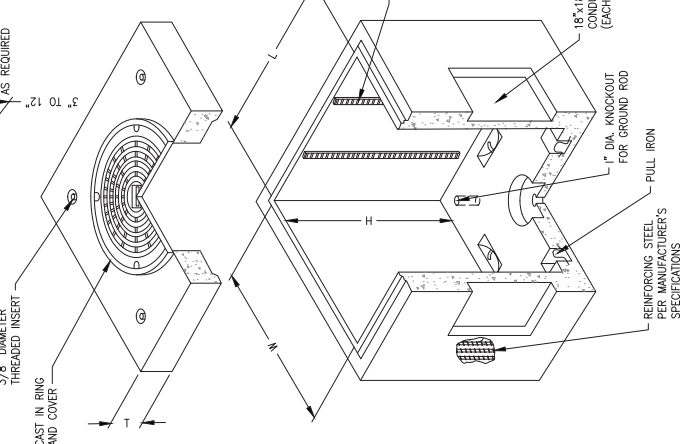
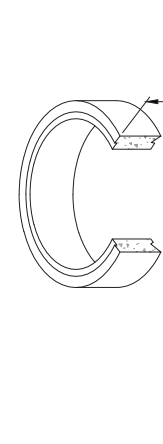
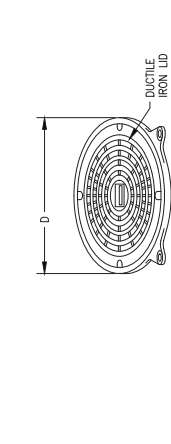

CONCRETE FIBER VAULT WITH MANHOLE LID
SCALE: NONE

VAULT DIMENSIONS

VAULT TYPE	L" INCH	W" INCH	H" INCH	LID HINGED OR MANHOLE	X" INCH	Y" INCH	D" INCH
IV-CV	48	48	48	6 MIN	24	36	36
V-CV	48	72	72	6 MIN	N/A	N/A	36

NOTES:

- SUPPLY TYPE IV FIBER VAULT WITH A TAMPERPROOF HINGED METAL LID FOR UNPAVED AREAS, OR A TAMPERPROOF HEAVYDUTY MANHOLE-STYLE LID IN PAVED AREAS. SUPPLY FIBER VAULTS, LIDS, AND COVERS RATED FOR ASHTO LRFD HL-93 LOADING.
- SUPPLY TYPE V-CV FIBER VAULT WITH A MANHOLE-STYLE LID ONLY.
- SUPPLY MANHOLE LIDS WITH A HOLE OR SLOT FOR REMOVAL WITH A LEVER OR HOOK. SUPPLY HINGED METAL LIDS WITH DROP HANDLES.
- SUPPLY VAULTS WITH A PERMANENT INTERNAL LADDER.
- PROVIDE FIBER VAULT LIDS MARKED, "PARK CITY FIBER OPTIC, FIBER OPTIC, OR SIMILAR," USING MIN 3 INCH HIGH LETTERING WITH 1/8" INCH THICKNESS. FORM LETTERS BY ENGRAVING, CASTING, STAMPING, OR WITH A PRECISE WELD BEAD.
- PROVIDE HINGED METAL LID WITH A MINIMUM OF 3/23" HIGH DIAMOND PATTERN OR SIMILAR SURFACE.
- PROVIDE FIBER VAULTS WITH A HEAVY-DUTY, NON-METALLIC CABLE STORAGE BACK SYSTEM. PROVIDE RACK ARMS AND STANCHIONS CAPABLE OF SUPPORTING A MINIMUM OF 250 LB FOR TYPE IV-CV FIBER VAULT RACKS; INCLUDE A MINIMUM OF 36 INCH RACK STANCHIONS AND 4 RACK ARMS. FOR TYPE V-CV FIBER VAULTS, INCLUDE A MINIMUM OF 45 INCH RACK STANCHIONS AND 5 RACK ARMS.
- CONDUITS PENETRATE FIBER VAULT AT THIN WALL SECTIONS ONLY. CORE DRILL HOLE IN THIN WALL SECTION TO CONDUIT SIZE PLUS 1/4". DO NOT "KNOCK OUT" THE THIN WALL SECTION.
- COMPLY WITH OSHA REQUIREMENTS FOR ENCLOSED WORK SPACES.
- BOND AND GROUND ALL EXPOSED METALLIC COMPONENTS OF THE FIBER VAULT PER NEC 250 IF ARMORED FIBER OPTIC CABLE IS USED.
- INSTALL CONDUIT PLUGS ACCORDING TO UDOT STANDARD SPECIFICATION 1355.3.
- ALIGN ATMS CONDUIT BY COLOR ON EACH SIDE OF FIBER VAULT.
- EXTEND GROUND ROD A MINIMUM OF 4 INCHES AND A MAXIMUM OF 6 INCHES ABOVE BOTTOM OF FIBER VAULT.
- USE GROUND ROD BRIDGE CLAMP FOR BONDING TO GROUND ROD. ATTACH NOT MORE THAN 4 WIRES PER CLAMP.
- DO NOT CUT GROUND RODS.
- INSTALL VAULT PLUMB AND LEVEL. GRADE BACKFILL FLUSH WITH VAULT.
- REFER TO THE FOLLOWING UDOT STANDARD SPECIFICATIONS FOR ADDITIONAL INFORMATION:
-13431 - PRECAST CONCRETE FIBER OPTIC AND UTILITY VAULT
-13553 - ITS CONDUIT
-13594 - FIBER OPTIC COMMUNICATION
-13595 - ITS INTEGRATION, INSPECTION, TESTING, AND ACCEPTANCE

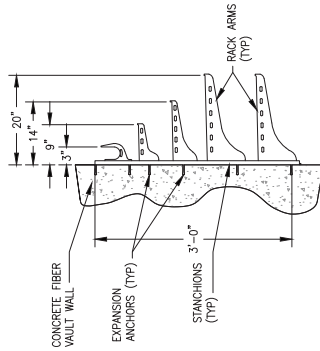

TYPICAL CABLE RACK
SCALE: NONE

ITS CABINET

DATE	03/2024
REV.	

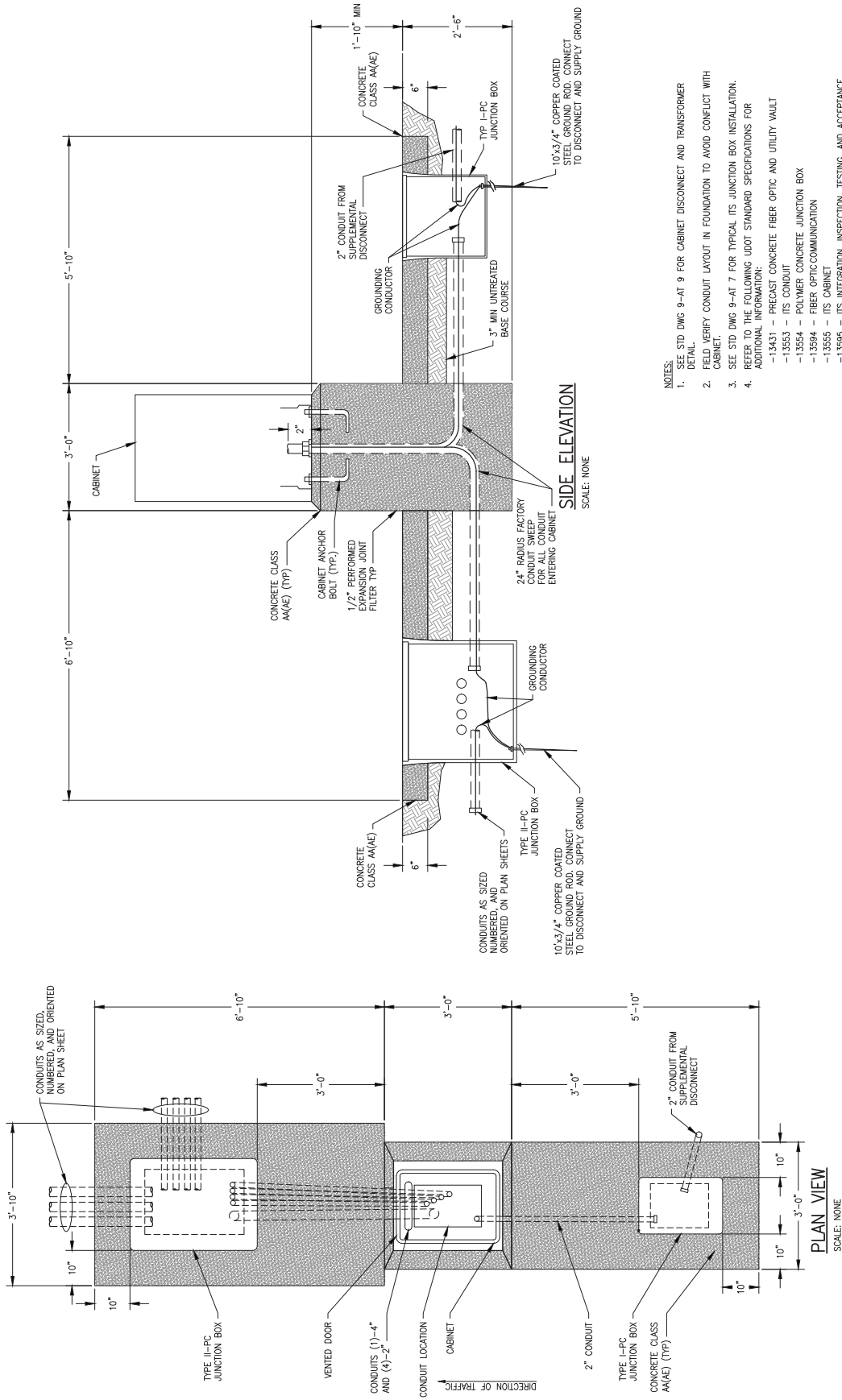

- NOTES:
- SEE STD DWG 9-AT 9 FOR CABINET DISCONNECT AND TRANSFORMER DETAIL.
 - FIELD VERIFY CONDUIT LAYOUT IN FOUNDATION TO AVOID CONFLICT WITH CABINET.
 - SEE STD DWG 9-AT 7 FOR TYPICAL ITS JUNCTION BOX INSTALLATION. REFER TO THE FOLLOWING UDOT STANDARD SPECIFICATIONS FOR ADDITIONAL INFORMATION:
 -13431 - PRECAST CONCRETE FIBER OPTIC AND UTILITY VAULT
 -13553 - ITS CONDUIT
 -13554 - POLYMER CONCRETE JUNCTION BOX
 -13584 - FIBER OPTIC COMMUNICATION
 -13555 - ITS CABINET
 -13585 - ITS INTEGRATION, INSPECTION, TESTING, AND ACCEPTANCE
 -

DATE	03/2024
REV.	

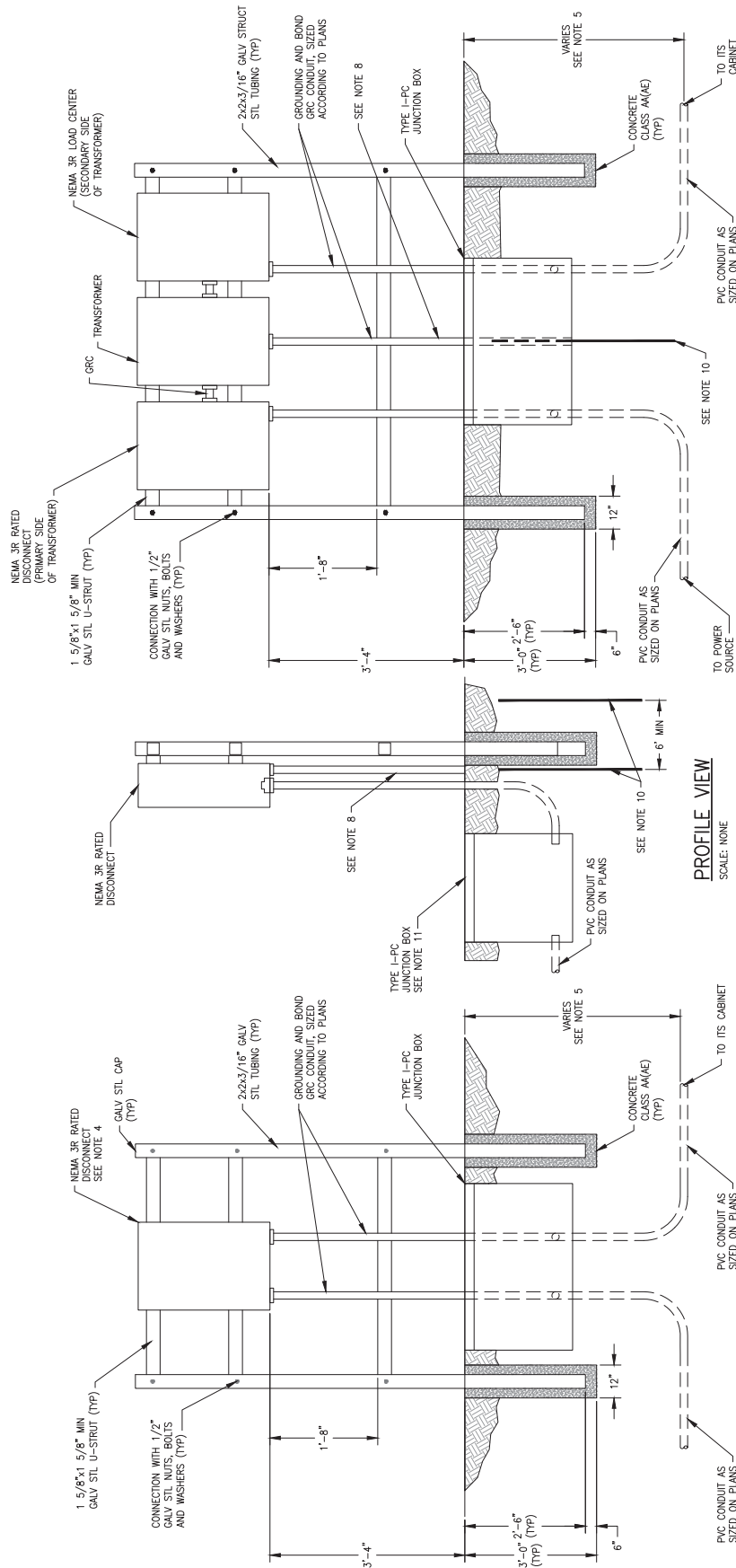

SUPPLEMENTAL DISCONNECT WITH TRANSFORMER FRAME B
SCALE: NONE

SUPPLEMENTAL DISCONNECT WITH TRANSFORMER FRAME A
SCALE: NONE

- NOTES:**
1. LOCATE FRAME 10 TO 15 FT FROM CABINET AND ITS EQUIPMENT.
 2. ROUND OFF SHARP EDGES OF STRUCTURAL TUBING, PAINT CUT ENDS OF FRAMING STRUTS WITH ZINC RICH PAINT.
 3. APPLY CORROSION PROTECTION TO PORTION OF STRUT BELOW GRADE.
 4. ATTACH TRANSFORMER, DISCONNECT AND LOAD CENTER TO FRAMING STRUT WITH WATERTIGHT GASKETS AND GALVANIZED HARDWARE.
 5. REFER TO UDOT STANDARD SPECIFICATION 13553 FOR CONDUIT DEPTH.
 6. USE ONLY FACTORY PRODUCED CONDUIT SIZES PER PLAN.
 7. SIZE ENCLOSURE TO ACCOMMODATE CONDUIT SIZES PER PLAN.
 8. INSTALL 1 INCH SCHEDULE 80 PVC AS PROTECTION FOR GROUNDING ELECTRODE CONDUCTOR.
 9. ALL MATERIALS USED MUST BE RATED FOR THE VOLTAGE AND CURRENT AS SHOWN.
 10. INSTALL 2 EACH 10 FT X 3/4 INCH GROUND RODS DIRECTLY BELOW SUPPORT FRAME, SPACED MINIMUM 6 FT APART AT TRANSFORMER LOCATIONS. INSTALL 6 AWG COPPER GROUNDING ELECTRODE CONDUCTOR BETWEEN GROUND RODS ON RICHES BELOW GRADE AND BOND TO TRANSFORMER SECONDARY ACCORDING TO NEC ARTICLE 250 REQUIREMENTS.
 11. LOCATE TYPE I PC JUNCTION BOX MINIMUM 6 FT AND MAXIMUM 10 FT FROM FRAME.
 12. REFER TO THE FOLLOWING UDOT STANDARD SPECIFICATIONS FOR ADDITIONAL INFORMATION:
 - 13431 - PRECAST CONCRETE FIBER OPTIC AND UTILITY VAULT
 - 13553 - ITS CONDUIT
 - 13554 - POLYMER CONCRETE JUNCTION BOX
 - 13594 - FIBER OPTIC COMMUNICATION
 - 13555 - ITS CABINET
 - 13595 - ITS INTEGRATION, INSPECTION, TESTING, AND ACCEPTANCE

ATTACHMENT A – 2025 Public Water Field Observation Guidelines

PUBLIC WATER SYSTEM FIELD OBSERVATION GUIDELINES

***FOR PROJECTS WITHIN THE
PARK CITY WATER SERVICE DISTRICT***



YEAR 2025

REV. 2

FORWARD

This manual provides information to assist the field representative in his duties of observing the progress and quality of public water line construction within the Park City Water Service District, Park City, Utah, and determining if the work is proceeding in accordance with *Park City Design Standards, Construction Specifications and Standard Drawings*. The information, checklists and procedures included in the manual are not all inclusive, but are intended to serve as guidelines for the performance of periodic construction observations, required sampling and testing observation by the field representative. **It is important that field representatives contact the Project Manager or the Park City Engineer for clarification if there are any questions related to the requirements of the Park City Design Standards, Construction Specifications, and Standard Drawings.**

DISINFECTING

All new water mains, services, and appurtenances shall be disinfected in accordance with AWWA Standard C651-05.

The method typically employed by the Contractor to disinfect new water distribution systems is to place calcium hypochlorite granules in the pipeline as it is being installed. Reference *Park City Design Standards and Construction Specifications*, Appendix 703A. The field representative should pay special attention to the following items:

- Refer to Table No. 1 of the above referenced Appendix for the number of ounces to be used per pipe diameter and pipe interval to achieve the necessary disinfection concentration.
- **Active chlorine content of disinfecting solution within water service tubing (CTS) for water services shall not exceed 12%.**
- Water mains shall be filled slowly to prevent "pushing" the calcium hypochlorite granules to one end of the pipe line. If the new water lines are to be filled by introducing water from the existing water distribution system, via opening the isolation valve between the two systems, the field representative shall monitor the opening of the valve. The field representative shall pay special attention to the following during water system filling by the Contractor:
 1. Verify that the static water pressure of the distribution system (typically 40 psi) is capable of overcoming the static head required to fill the new water line.
 2. Be certain a means of releasing air at the high point of the water system to be filled is provided and is open.
 3. The isolation valve shall be opened only slightly (**existing water system valves are to be operated only by Water Operations staff**).
 4. Listen for water passing the valve. The valve shall be closed immediately if it appears that the water pressures begin to equalize on each side of the valve. Backflow of chlorinated water into the existing water distribution system must not occur.
- After the water mains and services have been filled by the Contractor, the field representative shall sample and test the water for chlorine concentration. Observe the following:
 1. Select sampling frequency and locations to achieve representative samples. Typical locations for samples at water meter services, taps or fire hydrants. The sampling frequency will depend on length of the water line being chlorinated, availability of sampling points, and results of chlorination concentration tests.
- The field representative should observe the disinfection of the interior of all pipe, fittings, valves, tapping sleeves, and other materials when existing water mains are cut into or repaired. The Contractor can accomplish this by swabbing the materials with a hypochlorite solution. Reference *Park City Design Standards and Construction Specifications*, Appendix A.
- **Remember: Good disinfection practices improve the opportunity for successful bacteriological test results.**

WATER SYSTEM FLUSHING

Flushing of the installed water system is to be completed in two steps. The initial flushing is to be performed following installation and disinfection of the water main but prior to hydrostatic testing. The final flushing is to be performed following hydrostatic testing and leakage testing.

INITIAL FLUSHING

The following items should be considered by the field representative and may need to be reviewed with the Park City Engineer:

1. When notified that the Contractor intends to begin the initial flushing but before the Contractor utilizes water contact the Park City Water Department to be certain that water is available from the City for flushing purposes. **Inform the Contractor not to begin flushing without authorization (existing water system valves are to be operated only by Water Operations staff).**
2. Review with the Contractor the proposed discharge location for flushing operations and the method by which the Contractor intends to control the discharge of chlorinated water from the water system. **Fire hydrants are not acceptable points for initial flushing operations.**
Typically, Contractors will discharge the water into a water truck or tank and haul the water offsite for disposal. Chlorinated water shall not be allowed to be discharged in a manner that it could now onto vegetation or into streams, waterways, storm drains or sanitary sewer systems.
3. Determine the required diameter of opening(s) for discharge from the water line. The opening must be sized to achieve velocities capable of moving dirt and rock through the pipe, approximately **6 to 8 feet per second**. Note that required flowrate and opening size(s) referenced in AWWA Table 3 Required Flow and Openings to Flush Pipelines, is based on only 2.5 feet per second velocity at 40 psi pressure. *Required opening size will be determined based on site specific available water system pressure to achieve the required velocity.*
4. Determine the total volume of water to be expelled from the section of water system being flushed. The entire contents of the water line must be discharged and replaced with new water. To determine the volume required, ensuring that the entire pipe line has been flushed, utilize the following formula:
$$V = (\pi d^2 / 4) (L) (7.481); \quad \text{where: } V = \text{volume (gallons)}$$
$$\pi / 4 = \text{area}$$
$$d = \text{pipe diameter (feet)}$$
$$\pi = 3.141$$
5. If the section of water line to be flushed is very long, making the transport of sediment and rock to the discharge location may be difficult, an intermediate discharge location for flushing should be considered. *The end of a fire service line, prior to setting the hydrant, or a properly sized service tap could be utilized.*
6. After initial flushing has been completed, perform sampling and testing for "low" chlorination concentration.

FINAL FLUSHING

1. Utilize the same procedure for final flushing as for initial flushing, except that concerns regarding the chlorine concentration of discharge water do not apply.
2. Fire hydrants are to be flushed and can be utilized as flushing locations.
3. Services are to be flushed at the meter vaults. *Proper flushing of the service lines is important since water samples for bacteriological testing are typically taken at the service lines.*

Pipe Diameter inches	Flow Required to produce 2.5 ft/s (approx) velocity in main gpm	1	Size of tap inches 1-1/2 Number of Taps on Pipe#	2	Number of 2-1/2 in. Hydrant Outlets*
4	100	1	–	–	1
6	200	–	1	–	1
8	400	–	2	1	1
10	600	–	3	2	1
12	900	–	–	2	2
16	1600	–	–	4	2

*With a 40 psi pressure in the main with the hydrant flowing to atmosphere, a 2-1/2 inch hydrant outlet will discharge approximately 100-0 gpm and a 4-1/2 inch hydrant outlet will discharge approximately 2500 gpm.

HYDROSTATIC TESTING

Hydrostatic testing is required for every section of water main (valve to valve). Testing every section is intended to test both sides of isolation valves to ensure proper functioning of the valve. Prior to hydrostatic testing and leakage testing the water system should be flushed and tested for proper disinfection.

HYDROSTATIC TESTING

The specified hydrostatic test pressure is to be met at the highest elevation in the section of water line being tested. The specified test pressure shall be achieved by means of a Contractor supplied pump/gauge system connected to the pipe. The gauge shall have sufficient increments to enable accurate readings to be taken.

To achieve proper hydrostatic test pressure at the highest elevation of the water line section being tested, consider the locations available for installing the testing apparatus. To determine the required test pressure at the test gauge, utilize the following formula:

$$P_g = P_r + (H_v - H_g) / 2.31;$$

where: P_g = required gauge pressure reading (psi)
 P_r = required test pressure (psi)
 H_v = elevation at highest valve (feet)
 H_g = elevation at gauge (psi)

Note: 1 psi = 2.31 feet of elevation, or 0.43 psi X elevation difference in feet.

The following items should be considered and may need to be reviewed with the Park City Engineer:

- The possibility of requiring/requesting a water valve to be installed in the water main to reduce the pressure difference in the water line to be tested. This may occur when there is a significant difference in elevation between water valves;
- The installation of an additional service tap to accommodate proper testing.
- In achieving the required hydrostatic pressure at the highest elevation of the water line section being tested, the hydrostatic pressures at the lowest elevation may exceed acceptable pressures for the pipe, valves or fittings. Typically, if the calculated pressure at the lowest elevation exceeds 300 psi, the City Engineer should be notified before testing is performed.

HYDROSTATIC TESTING

The field representative shall perform all sampling for bacteriological testing and deliver samples to the Summit County Health Department (or a pre-approved state certified laboratory) for analysis. To achieve consistent and representative sampling, the following procedures shall be observed by the field representative:

- Select the location and number of samples to be taken. Samples are typically taken at water meter services and ends of the water line. Intervals of 200 feet between sampling locations is preferred.
- Procedures for obtaining samples for bacteriological testing of the water system are as follows:
 1. Obtain sample bottles from the Public Works Water Department office or Summit County Health Department, if not available in the office.
 2. When sampling, first disinfect or sterilize the discharge area.
 3. Open the control valve slowly and allow water to flow for a short period.
 4. Close the valve slightly to reduce the flowrate and fill the sample bottle to the fill line. Place the lid on the sample bottle and seal shut. Note: Be sure to identify the location of the sample bottle before obtaining other samples.
- After all samples are taken, complete the identification form and add other pertinent information to each sample bottle. Reference the sample identification form contained in the Report Forms and Checklists section of this manual. *Note: Pay special attention to Item No. 2, "Investigative Sample (not included on official records)" on the identification form. Always check this box on the form.*

TABLE 1 ALLOWABLE LEAKAGE PER 1000 FEET OF PIPELINE									
(gph)	Nominal Pipe Diameter (inches)								
Avg. Test Pressure (psi)	3	4	6	8	10	12	14	16	18
250	.36	.47	.71	.95	1.19	1.42	1.66	1.90	2.14
225	.34	.45	.68	.90	1.13	1.58	1.58	1.80	2.03
220	.32	.43	.64	.85	1.06	1.28	1.48	1.70	1.91
175	.30	.40	.59	.80	.99	1.19	1.39	1.59	1.79
150	.28	.37	.55	.74	.92	1.10	1.29	1.47	1.66
125	.25	.34	.50	.67	.84	1.01	1.18	1.34	1.51
100	.23	.30	.45	.60	.75	.90	1.05	1.20	1.35

*EXCERPTED FROM AWWA C600

In inch-pound units,

$$L = \frac{SD\sqrt{P}}{133,200}$$

Where,

- L = testing allowance (makeup water), in gallons per hour
- S = length of pipe tested, in feet
- D = nominal diameter of the pipe, in inches
- P = average test pressure during the hydrostatic test, in pounds per square inch (gauge)

This formula is based on a testing allowance of 11.65 gpd/mi/in. of nominal diameter at a pressure of 150 psi.

FIELD OBSERVATION REPORT FORMS AND CHECKLISTS

This section includes typical forms checklists that are to be used as generalized guidelines to assist in the verification of the material and dimensional requirements of the Park City Design Standards and Construction Specifications. Field Representatives are to utilize the checklists during water system construction to assist the Contractor in understanding the requirements of the final product and during the final walk-through to verify consistency with the standards and specifications. Additionally, the fire hydrant inspection forms, illustrating the placement of a fire hydrant in three different terrain conditions, are to be completed during the Final Walk-through to provide the Park City Engineer with information regarding the hydrant's installed elevation and location relative to the curb and gutter and the auxiliary valve.

FIELD OBSERVATION QUICK CHECKLIST

WATER LINE INSTALLATION:

- Verify that marking tape and locator wire is installed above the water main in the trench

- Verify that water main is bedded with approved gravel-sand material

- Verify that water main is installed at proper horizontal location (within pavement and inside of curb & gutter limits) and depth. Require additional survey staking be provided if necessary to determine design grades and curb & gutter alignment

- Verify that correct polyethylene encasement is provided and properly installed

- Verify that wax tape coating system is provided and properly installed on all buried bolts & nuts. Verify the cathodic protection system (if required) is provided and properly installed.

- Verify that thrust blocking is of adequate size, extended to undisturbed soil and that the pipe is wrapped with polyethylene before concrete is placed

- Verify that service taps are at 45 degrees to the main with 2 feet minimum separation

- Verify that every service corporation stop is open. This can be verified during flushing procedures

- Verify that water valves are properly set, valve boxes are clear of debris, and that a valve key can be placed on the valve. This must be verified during the final walk-through

FIELD OBSERVATION QUICK CHECKLIST

FIRE HYDRANT INSTALLATION:

- Verify that adequate gravel is placed around the fire hydrant base
- Verify that thrust blocking is properly placed and fire hydrant drain ports are not covered by concrete.
- Flush fire hydrant drain ports. Close main hydrant valve to the position at which the drains open and allow flow through the drains under pressure for about ten seconds to flush the drains. Then close hydrant valve completely.
- Check fire hydrant barrels for drainage. Remove nozzle cap, open hydrant valve, allow hydrant to run briefly and close hydrant valve. Place palm of hand over nozzle outlet. Drainage should be sufficient to create a suction.
- Check fire hydrant nozzle caps for thread damage from impact or cross threading
- Verify that the auxiliary valve is in the wide open position.
- Verify that fire hydrant markers are installed
- Verify that fire hydrant is properly extended above grade and hydrant pad is properly constructed. See *Fire Hydrant Inspection Sheet*.

FIELD OBSERVATION QUICK CHECKLIST

WATER METER INSTALLATION:

- Verify that meter service assembly materials are in accordance with Checklist. *See checklists for specific size water meter.*

- Verify that water meter box is adjusted to grade. *See meter box adjustment detail sheet.*

- Verify that water meter box is located properly. Require additional staking as required for verification.

TYPICAL PROCESS FOR WATER SYSTEM CONSTRUCTION

1. INSTALL WATER MAIN AND FIRE HYDRANTS
If the Contractor elects to perform hydrostatic testing of water services independently of the water main, Items 3, 5, 7 and 9 will be performed on the water main prior to installation of the water services.

2. INSTALL WATER SERVICES
If water services are installed after water main testing, the each services must be disinfected separately.

3. INITIAL FLUSHING OF WATER MAIN
Sampling and testing for "high" chlorine concentration is performed prior to initial flushing.

4. INITIAL FLUSHING OF WATER SERVICES

5. PERFORM HYDROSTATIC AND LEAKAGE TESTING ON WATER MAIN

6. PERFORM HYDROSTATIC AND LEAKAGE TESTING ON FIRE HYDRANTS & WATER SERVICES

7. FINAL FLUSHING OF WATER MAIN
Sampling and testing for "low" chlorine concentration is performed following final flushing.

8. FINAL FLUSHING OF FIRE HYDRANTS & WATER SERVICES

9. PERFORM BACTERIOLOGICAL TESTING

10. ALLOW ACTIVATION OF WATER SYSTEM
Permanent opening of isolation valves upon receipt of successful bacteriological test results.



WATER SYSTEM TESTING SUMMARY REPORT

PROJECT NAME _____ PROJECT # _____

CONTRACTOR _____

WATER SYSTEM SECTION _____

DISINFECTION: 703.2.12C & J

TYPE OF CHLORINE: GRANULAR INJECTION, WHERE: _____

SAMPLE LOCATION: _____

DATE TIME CHLORINE, PPM

START: _____

END: _____

RESULT: PASS FAIL INITIALS _____

DISPOSAL OF CHLORINATED WATER: _____

FLUSHING: 703.2.12A

MAIN:

LENGTH OF SECTION: _____ feet PIPE MAT'L: _____ PIPE DIAMETER: _____ inches

CITY WATER USED OTHER

FLUSH ORIFICE SIZE: _____ inches STATION: _____

ESTIMATED TO BE FLUSHED: _____ gal. ESTIMATED DURATION: _____ min.

ACTUAL DURATION: _____ min.

DATE: _____ INITIAL _____ FINAL _____ INITIALS _____

SERVICES:

LOT No's: _____

DATE: _____ INITIAL _____ FINAL _____ INITIALS _____

HYDRANTS:

STATION: _____ INITIAL _____ FINAL _____ INITIALS _____

STATION: _____ INITIAL _____ FINAL _____ INITIALS _____

STATION: _____ INITIAL _____ FINAL _____ INITIALS _____

BACTERIOLOGICAL SAMPLING: 703.2.12M

DATE OF SAMPLE: _____

SAMPLE TAKEN BY: _____ P.O. No.: _____

SAMPLES DELIVERED TO: _____ DATE: _____ TIME: _____

SAMPLES ANALYZED BY: _____

SAMPLE NO. 1 TAKEN AT: _____ PASS FAIL

SAMPLE NO. 2 TAKEN AT: _____ PASS FAIL

SAMPLE NO. 3 TAKEN AT: _____ PASS FAIL

DATE OF RESULT: _____ (REFERENCE ATTACHED TESTING REPORT)



WATER SYSTEM TESTING SUMMARY REPORT (continued)

HYDROSTATIC TEST: 703.2.11

MAIN: INITIAL TEST DATE: RETEST DATE: TEST PRESSURE @ START: @ 30 min: @ 60 min: @ 90 min: @ FINISH: [] PASS [] FAIL INITIALS

COMMENTS

SERVICES:

LOTS SERVICED:

INITIAL TEST DATE: RETEST DATE: TEST PRESSURE @ START: @ 30 min: @ FINISH: [] PASS [] FAIL INITIALS

COMMENTS

HYDRANTS:

STREET & STATION: TEST DATE: @ START: @ 30 min.: @ FINISH: [] PASS [] FAIL INITIALS

COMMENTS

LEAKAGE TEST: 703.2.11

DATE LENGTH OF SECTION: PIPE MAT'L.: DIAMETER LENGTH OF TEST: ACCEPTABLE LOSS, per AWWA C600. TABLE 6: GALLONS USED: RESULT: [] PASS [] FAIL INITIALS

THIS PAGE IS INTENTIONALLY LEFT BLANK

THIS PAGE IS INTENTIONALLY LEFT BLANK

ATTACHMENT B – Old Town Stairway Construction Details & Plans



A guide to "Old Town Stairway" Construction

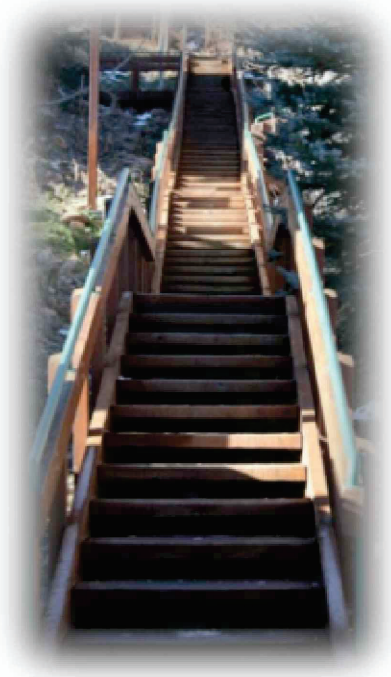

By Chase Bowler

	DATE	<p>OLD TOWN STAIRWAY</p>	STD. PLAN
	3/2020		<p>881-A</p>
	REV.		

- A. **Connections and Parts**.....3
- B. **Uprights**.....4
- C. **Railing**.....4-5
- D. **Landings**.....5-7
- E. **Landing connections**.....8
- F. **Steps**.....9
- G. **Composite Wood**.....9

II. Code requirements and Preferences

- A. **Diamond-Grip Chanel**.....10
- B. **Galvanized Carriage Bolts**.....10
- C. **Counter Sink**10

	DATE	OLD TOWN STAIRWAY	STD. PLAN
	3/2020		881-B
	REV.		

Connections and Parts

A)

Note that all connections are carriage bolts, having the smooth side inward, and the threads on the outside with washer and nut.

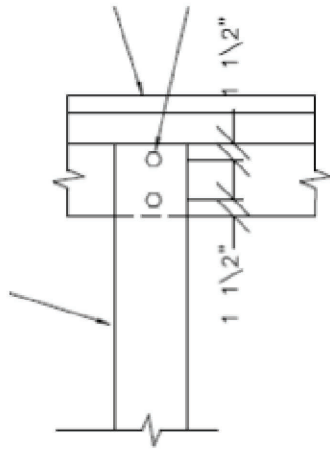

B)

Two bolts are recommended for upright and handrail connections. And when there is a splice in the wooden handrail support structure, than four bolts shall be used.

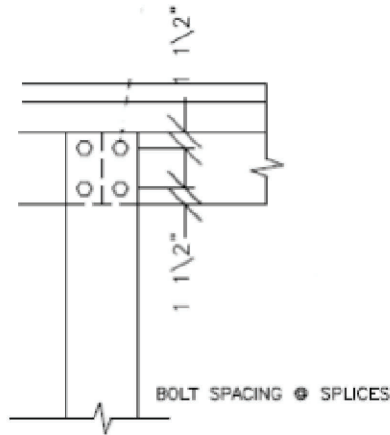

C)

Any change in angle should be connected with angle steel and appropriate carriage bolt washer and nut combination.

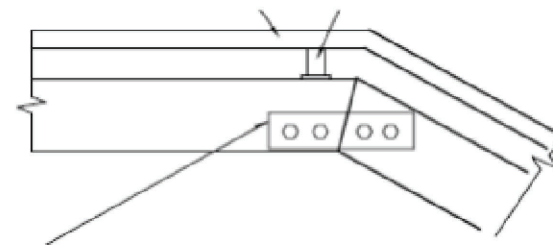

DATE

3/2020

REV.

OLD TOWN STAIRWAY

STD. PLAN

881-C

Uprights

A)

All supports must be founded in a concrete poured base 12" in diameter, and connected using four galvanized steel bolts.

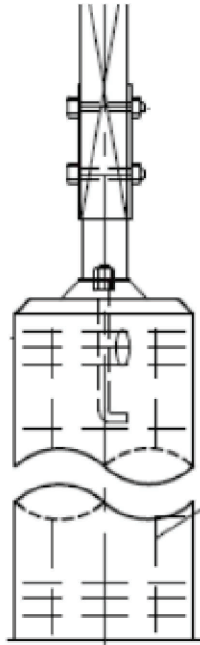

B)

According to code all terminations of handrails must curve back around and connect into the wood end.

IBC 1012.6 Handrail Extensions "Handrails... shall be continuous to the handrail of an adjacent stair flight or ramp run."

And "...handrails shall extended horizontally at least 12in beyond the top riser and continue to slope for the depth one tread beyond the bottom riser."

Railing

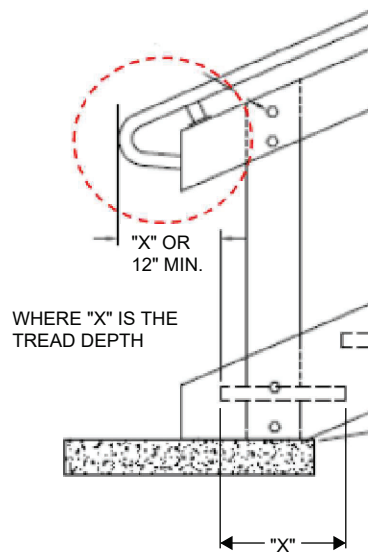

DATE

3/2020

REV.

OLD TOWN STAIRWAY

STD. PLAN

881-D

IBC 1012.3.1 Handrail Graspability "Handrails with circular cross section shall have an outside diameter of at least 1 3/4 in and no greater than 2 in."

IBC 1012.5 Fittings "Hand rails shall not rotate within their fittings."

IBC 1009.8 Stairway Landings "There shall be a floor or landing at the top and bottom of each stairway. The width of landings shall not be less than the width of stairways they serve."

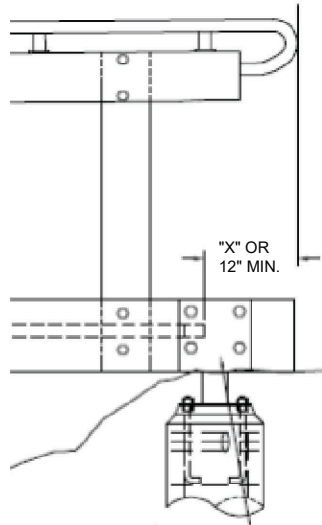

WHERE "X" IS THE TREAD DEPTH



Landings

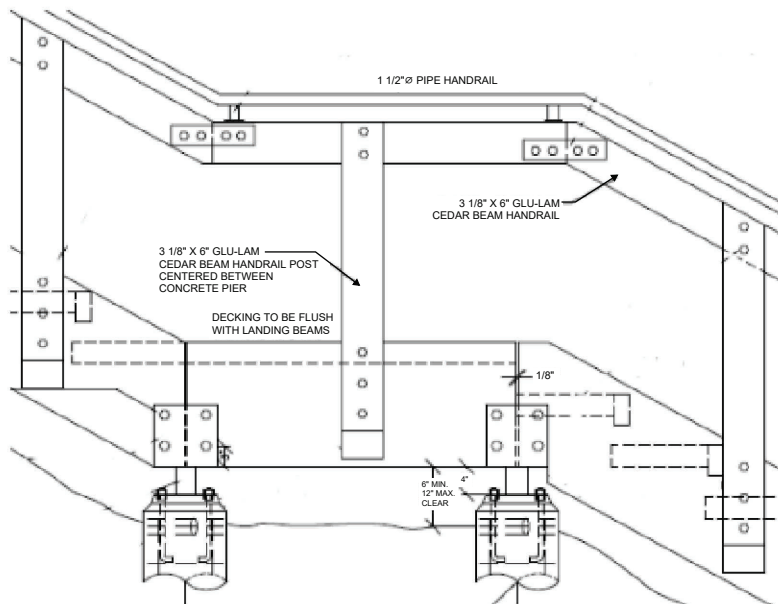

	DATE	<p>OLD TOWN STAIRWAY</p>	STD. PLAN
	3/2020		<p>881-E</p>
	REV.		

IBC 1009.9.2 Outdoor Conditions "Outdoor stairways and outdoor approaches to stairways shall be designed so that water will not accumulate on walking surfaces."

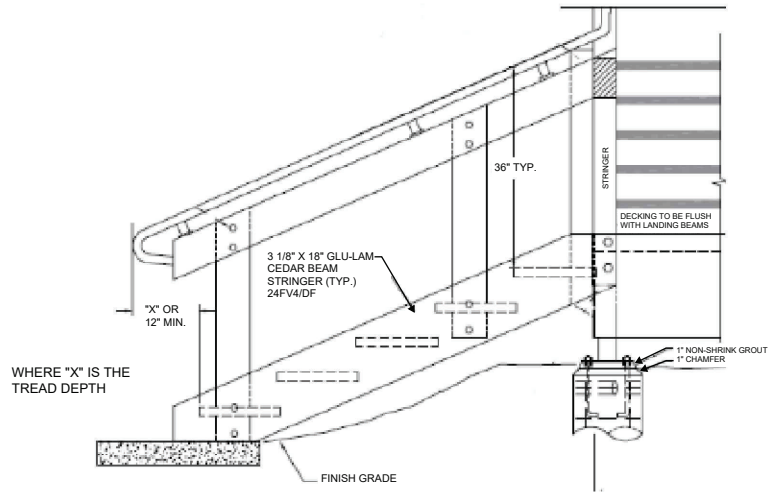

DATE
3/2020
REV.

OLD TOWN STAIRWAY

STD. PLAN
881-F

IBC 1009.10 Vertical Rise "A flight of stairs shall not have a vertical rise greater than 12 feet between floor levels of landings.

IBC 1009.4 Width "...width of stairways shall not be less than 44 in." unless "...occupant load of less than 50 shall have a width of no less than 36 in."

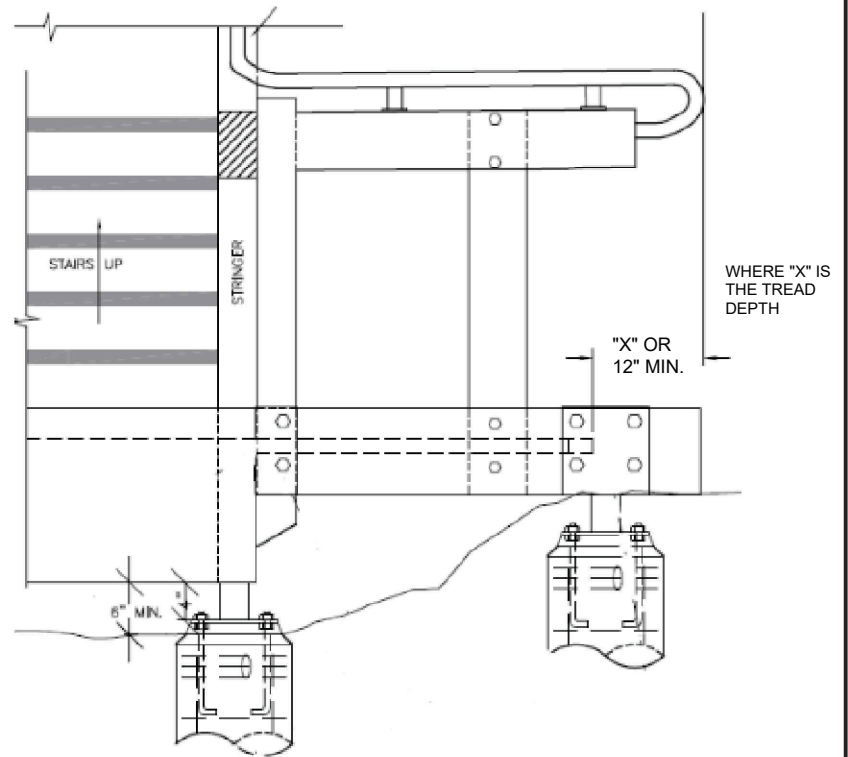

DATE

3/2020

REV.

OLD TOWN STAIRWAY

STD. PLAN

881-G

Landing connections

A)

All endings of stair landings must be connected with steel plating and carriage bolts to make for firm connections.

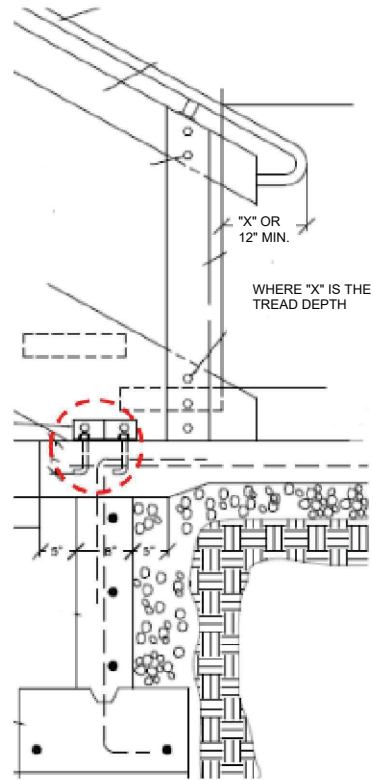

DATE

3/2020

REV.

OLD TOWN STAIRWAY

STD. PLAN

881-H

Steps

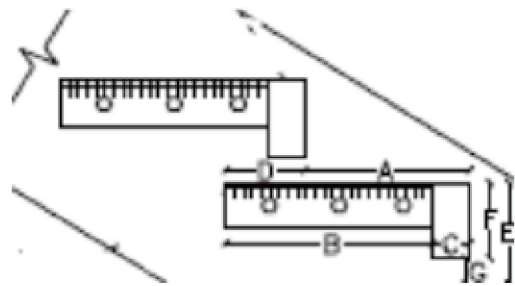

Composite Wood

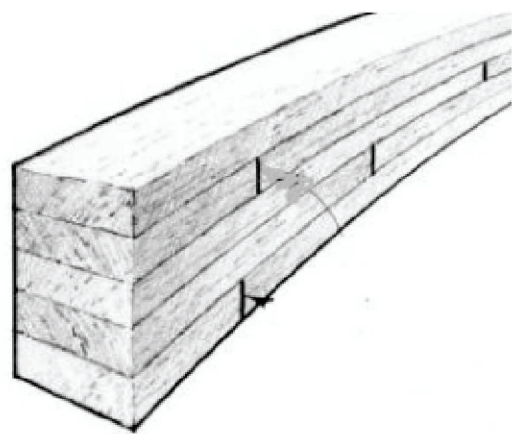

A)

It is recommended that the front of the steps be covered with 1.5 in. thick wood, to maintain consistency with the other stairs throughout the city.

IBC 1009.7.2 Riser Height and Tread depth "Stair riser heights shall be 7 in. maximum and 4 in. minimum.rectangular tread depths shall be 11 in minimum..."

IBC 1009.7.5 Nosing and Riser Profile "The radius of curvature at the edge of the tread shall be no greater than 9/16 in."

IBC 1009.7.5.2 Nosing Projection Uniformity "All nosing projections of the leading edges shall be of uniform size, including the projections of the nosing leading edge of the floor at the top of a flight."

B)

All wood used on the stairs must be of a composite form. This also allows for greater resistance to warping due to weathering, and having an enhanced strength.



DATE	3/2020
REV.	

OLD TOWN STAIRWAY

STD. PLAN	881-I
-----------	-------

Code Requirements and Preferences

A)

According to City preferences, on any landings or steps they must have a tread made of Diamond Grip Channel material.

ANSI 302.3 Openings "Openings in the floor surface be of a size that does not permit the passage of a ½ inch diameter sphere... Elongated openings shall be placed so that the long dimension is perpendicular to the dominant direction of travel."

IBC 1009.9.1 Stairway Walking surface "The walking surface of treads and landings of a stairway shall not be sloped steeper than one unit vertical in 48 units horizontal in any direction. Stairway treads and landings shall have a solid surface."

B)

It is strongly suggested that all connections excluding those found tying foundations into posts, are to be made using a carriage bolt combination, where the rounded portion of the bolt is to be consistently on the inside out of the stairs or in the path of travel.

C)

No countersinks are permitted when connecting any system, because the strength of the connection is reduced and a reduction in the life of the stairs.

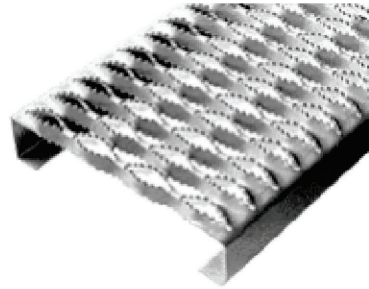
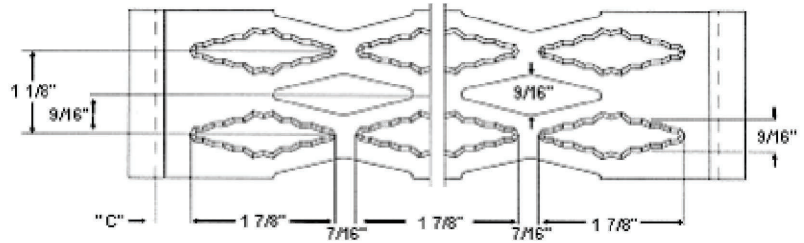

Discouraging Approach

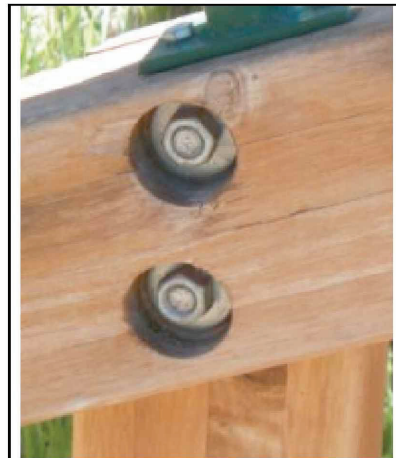

DATE

3/2020

REV.

OLD TOWN STAIRWAY

STD. PLAN

881-J

ORDINANCE 2026-11

AN ORDINANCE ADOPTING REVISED ENGINEERING STANDARDS AND SPECIFICATIONS

WHEREAS, the City Council of Park City last adopted the American Public Works Association Utah Chapter standard plans and specifications and Park City Supplemental Standard Plans and Specifications (“Standards”) in June 2025 (Ordinance 2025-15); and

WHEREAS, the Standards have and will continue to be updated periodically as new technology, policy changes, procedure changes, updated methods of design and construction are implemented, and infrastructure materials change; and

WHEREAS, in coordination with City Staff, the City Engineer prepared and recommends revisions to the Standards; and

WHEREAS, the Planning Commission held a public hearing on April 8, 2026, regarding updates to the Standards and recommends the City Council approve the same; and

WHEREAS, the City Council finds good cause for adopting the revised Standards;

NOW, THEREFORE, BE IT ORDAINED by the City Council of Park City, Utah:

Section 1. Adoption of Standards and Specifications. The 2026 American Public Works Association Utah Chapter Manual of Standard Specifications and Manual of Standard Plans and the Park City 2026 Supplemental Standard Plans and Specifications, which is attached as **Exhibit A**, are hereby adopted under Title 14, Chapter 8, Section 1 of the Park City Code.

Section 2. Effective Date. This ordinance shall become effective upon publication.

PASSED AND ADOPTED this 7th day of May, 2026.

PARK CITY MUNICIPAL CORPORATION

Mayor Ryan Dickey

Attest:

Michelle Kellogg, City Recorder

Approved as to form:

City Attorney’s Office

Exhibit A

2026 Park City Supplemental Standard Plans & Specifications



City Council Staff Report

Subject: Pride Month Resolution
Author: Michelle Kellogg, City Recorder
Department: Executive
Date: May 7, 2026

Summary Recommendation

Pursuant to the consent from three or more Council members, consider approving a resolution proclaiming June 2026 as Pride Month in Park City and supporting Pride Month activations.

Analysis

In addition to proclaiming June as Pride Month in Park City, the proposed Resolution authorizes City staff to perform the following activations:

- Display Pride banners on City light poles on Main Street during the month of June.
- Install transit decals exhibiting “Ride with Pride” during the month of June. The design will be consistent with the prior year’s theme, “Ride with Pride.”

Adopting a resolution, displaying banners on city light poles, and installing transit decals demonstrate Park City’s commitment to inclusion of LGBTQ+ residents by creating and supporting policies and programs that stand against discrimination and by promoting equality and opportunity for all community members.

Exhibits

Exhibit A: Pride Month Resolution

RESOLUTION PROCLAIMING JUNE 2026 AS PRIDE MONTH IN PARK CITY

WHEREAS, Pride Month is a time to celebrate the LGBTQ+ community's history, achievements, and ongoing fight for equality, while also acknowledging the struggles and injustices faced by LGBTQ+ individuals. It serves as a platform for education, awareness, and advocacy, promoting acceptance and understanding of the diverse LGBTQ+ community; and

WHEREAS, Utah Pride began with a small, informal gathering of Salt Lake City's LGBTQ+ community in 1974; and

WHEREAS, Park City welcomes residents and visitors from the LGBTQ+ community, their friends and family members, and straight allies who show their support; and

WHEREAS, Park City is committed to learning how to advance inclusion for LGBTQ+ residents by creating and supporting policies and programs that stand against discrimination and by promoting equality and opportunity for all community members; and

WHEREAS, Pride Month is a reminder that we should never let up in our efforts to ensure full equality, inclusion, and empowerment for our LGBTQ+ community.

NOW, THEREFORE, BE IT RESOLVED that the Mayor and City Council:

1. Hereby proclaim June 2026 as Pride Month.
2. Hereby authorize Pride banners on City light poles on Main Street during June 2026.
3. Hereby authorize transit decals exhibiting "Ride with Pride" during June 2026.

PASSED AND ADOPTED this 7th day of May, 2026.

PARK CITY MUNICIPAL CORPORATION

Mayor Ryan Dickey

Attest:

Michelle Kellogg, City Recorder

Approved as to form:

City Attorney's Office

City Council Staff Report

Subject: Set Executive Municipal Officer
Compensation Hearing
Department: Budget, Debts & Grants
Date: May 7, 2026



Recommendation

Set a date of May 21, 2026, during the Regular Meeting of the City Council, to hold the legally required public hearing for considering compensation increases for Executive Municipal Officers in the FY27 Final Budget. Utah Code section [10-3-818](#) requires the City Council to set and hold a separate public hearing before adopting a final budget if the final budget includes a compensation increase for an executive municipal officer. Executive municipal officer is a defined term, and it includes city manager, deputy city managers, city attorney, department heads, and department or division heads and their deputies.



City Council Staff Report

Subject: Bus Stop Improvement Project Phases 2&3 Construction Agreement and Little Kate Corridor Design Professional Services Agreement Amendment
Author: Steven Dennis PE, PMP
Sydney Maves
Department: Engineering & Transportation Planning
Date: May 7, 2026

Recommendation

Authorize the City Manager to execute a construction agreement with Acme Construction, Inc. (Acme), in a form approved by the City Attorney's Office, in an amount not to exceed \$10,000,000, for construction of Phases 2 and 3 of the Citywide Bus Stop Improvement Project. Concurrent with approval of the construction agreement, waive all City permitting fees associated with this work and deaccession "Art Kids" from the City's public art collection. Also authorize the City Manager to execute an amendment to the design professional services agreement (DPSA) with Kimley-Horn & Associates (KH) to evaluate Little Kate corridor alternatives that prioritize separation for bicyclists, pedestrians, and vehicles, increasing the agreement by \$140,000 for a total amended not-to-exceed amount of \$3,100,000.

Executive Summary

Park City Municipal is entering the final stage of a multi-year initiative to improve bus stops and enhance access to transit through new connections and traffic calming improvements along transit corridors throughout the community. This effort began in 2018 with a comprehensive study of bus stops across the City's transportation network. Using the results of that study, along with ridership and routing data, staff prioritized 83 bus stops for improvement. Phase 1, constructed in 2024, improved 18 bus stops. The remaining 65 bus stops are planned for construction in 2026 and 2027. The project has received significant grant funding from federal, state, and county sources, which currently covers approximately 85% of total project costs.

The Phases 2 and 3 construction agreement will advance the following improvements:

- 65 bus stops (locations can be viewed on the [Engage Park City webpage](#))
- 25 shelters
- 20+ new traffic calming elements
- 10+ new crosswalks
- 750 feet of improved sidewalk
- 400 feet of new sidewalk
- 3/4 mile of corridor improvements (subject to further City Council approval)

In response to community feedback and City Council direction, staff will reevaluate the Little Kate corridor and return to City Council with alternatives that better separate bicyclists, pedestrians, and vehicles. To preserve external grant funding and maintain

overall project momentum, this work will remain within the Bus Stop Improvement Project but be deferred to the planned 2027 construction phase, subject to future City Council approval. Deferring this corridor element will allow other project components, including bus stop improvements, to proceed while staff completes additional design analysis and continues engagement with City Council before any construction advances along Little Kate Road. The proposed amendment to the KH DPSA will fund this additional effort. Depending on the alternative ultimately approved by City Council, additional environmental documentation may also be required.

Analysis

On April 14, 2026, three contractors submitted bids in response to the City's invitation to bid. Acme submitted the lowest responsive bid and has the qualifications necessary to perform the work. Construction is anticipated to begin later this month and continue through December 2026. Following a winter shutdown, work will resume in spring 2027.

Approving the construction agreement now will allow the majority of Phases 2 and 3 to proceed on schedule while staff continues to reevaluate the Little Kate corridor consistent with recent City Council direction. The proposed amendment to the KH agreement will support the development of revised corridor alternatives that prioritize separation for all users before any construction proceeds in that area.

Given the geographic breadth of this project and the number of other major projects occurring citywide, construction impacts will be felt across the community. Staff and Acme are committed to timely and proactive communication regarding road closures and work adjacent to, or on, private property where access is authorized. Staff is also finalizing the temporary and perpetual easements required for project construction.

Public Art Deaccessioning

As part of the project, the existing shelter at the Learning Center, located near the intersection of Kearns Boulevard and Comstock Drive, will be replaced. "Art Kids", which is attached to the existing shelter, is part of the City's public art collection.

"Art Kids" was created by local artist Bob Commander in collaboration with Art Kids, a Park City nonprofit dedicated to empowering youth through the expressive arts. The piece was one of eight artworks commissioned through Park City's first official Public Art Program, established in 2003, and was installed in 2008 with support from the Park City Summit County Arts Council.

In accordance with [Park City Code Section 2-8-21](#), Staff recommends deaccessioning the artwork because it is beyond reasonable repair and requires excessive maintenance. City teams coordinated with relevant staff liaisons and presented the item to the Public Art Advisory Board, which recommended deaccessioning the artwork at the Learning Center site.

Previous City Council Engagement

- [February 2020](#): Park City finalized a Bus Stop Improvement and Accessibility Study to inventory bus stops and evaluate existing conditions and applicable ADA criteria.
- [September 2022](#): Based on the study, staff advanced 11 bus stops through concept design. Staff subsequently secured competitive grant funding to support full design and construction of at least 72 additional stops and ultimately advanced 73 new stops.
- [April 2023](#): City Council approved a DPSA with a third party to lead federal compliance, construction project management, and design work.
- [December 2023](#): Staff provided a project update summarizing public engagement efforts.
- [March 2024](#): City Council approved a DPSA with a fabricator to provide 20 new bus stop shelters.
- [April 2024](#): City Council approved a construction agreement for Phase 1 improvements at 18 bus stops.
- [November 2024](#): City Council approved a DPSA establishing a new third party as the federal compliance and design lead for the remaining Phase 2 and 3 bus stop locations.
- [July 2025](#): City Council approved an amendment to the fabricator DPSA to expand scope for additional shelters and field installation at 28 of the remaining stops receiving shelters.
- [August 2025](#): Staff provided a project update covering progress to date, upcoming design and construction phases, planned amenities and first-/last-mile improvements, public art integration, funding sources, and the timeline for additional community engagement.
- [February 2026](#): Staff provided a project update on community outreach, easement acquisition, and options for addressing a funding gap while advancing transit access and active transportation safety.
- [April 2026](#): Staff provided a project update specific to the Little Kate Pathway scope element. City Council directed staff to shift that work to the 2027 construction phase while reevaluating the corridor to prioritize separation for all users.

Funding

The project currently has more than \$17 million in programmed funding, approximately 85% of which is grant-funded. The tables below summarize available funding and estimated project costs. Staff continues to pursue additional external funding to further reduce the City's contribution.

Staff also requests that City Council waive all City permitting fees associated with this work. Because the estimated permitting fees exceed \$25,000, City Council approval is required under City policy. The estimated total permitting fee is \$37,000. Waiving those fees will reduce overall project costs and avoid unnecessary internal cost transfers on a City-funded project.

Project Budget

Funding Source	Amount
Federal Grants	\$12,001,135
State Grants	\$420,000 ¹
County Grants	\$2,400,000 ²
PCMC	\$2,674,262
Total	\$17,495,397

¹ Does not include an additional \$6,173,000 that has been applied for and prioritized.

² Does not include an additional \$750,000 that could be reprogrammed.

Estimated Project Costs

Scope of Work	Contract	Actuals	Status
Phase 1 Design	\$1,287,501	\$1,212,337	Complete
Phase 1 Construction	\$630,175	\$626,920	Complete
Phases 2&3 Design	\$3,100,000	\$1,926,237	\$1.2M to go Pending
Phases 2&3 Construction	\$10,000,000	\$0	Pending
Amenities	\$1,896,115	\$277,117	\$1.6M to go
Easements	\$600,000	\$4,200	\$595k to go
Total Estimated Cost	\$17,444,930		



City Council

Staff Communications Report

Subject: Re-Create 248: NEPA and Design Contract
Author: Julia Collins, Transportation Planning Manager
Conor Campobasso, Senior Transportation Planner
Department: Transportation Planning
Date: May 7, 2026

Recommendation

Consider a request to authorize the City Manager to execute a Professional Services Agreement (PSA) with Horrocks Engineers LLC, in a form approved by the City Attorney, with an initial total contract amount not to exceed \$2,100,000, for environmental clearance, preliminary engineering, and final design support to advance the Re-Create 248 Transit Priority Project, with the understanding that additional funding and future contract amendments or budget requests to complete the full scope of work for the Project will be presented to Council for approval.

Executive Summary

The Re-Create 248 Transit Study established a preferred direction for advancing transit priority improvements along the SR-248 corridor, connecting Quinn's Junction, Bonanza Drive, SR-224, and the Old Town Transit Center. The next phase of work is to move that concept through environmental clearance and into a level of engineering and design that positions the City for implementation and future grant competitiveness.

At prior City Council discussions, including direction provided in October, Council emphasized the importance of advancing this project quickly and maintaining flexibility as scope, funding, and agency requirements continue to evolve. This contract is intended to allow the City to move promptly into environmental review and design so the project remains positioned for phased implementation and future grant competitiveness. While a final implementation schedule will depend on environmental clearance, design progression, funding availability, and partner coordination, advancing this work now is important to keep the project on a timeline that supports the community's long-term mobility goals, including implementation milestones anticipated before 2034.

The City issued a Request for Statements of Qualifications (RSOQ) to firms in the City's transportation consultant pool to solicit qualifications for time-and-materials environmental, engineering, and design services needed to advance the project. The procurement was structured to allow the City to authorize work incrementally as the project scope, environmental pathway, funding strategy, and partner coordination continue to evolve. The anticipated work includes determining the appropriate National Environmental Policy Act (NEPA) pathway; preparing the required environmental documentation; refining project action limits; advancing preliminary engineering and final design; supporting public involvement, including stakeholder coordination in Bonanza, and property owner coordination; and assisting with funding strategy, grant applications, and agency coordination.

Because several key project variables are still evolving, including the ultimate NEPA class of action, the limits of the environmental document, the role of Richardson Flat Road and related park-and-ride elements, and the extent of phased implementation, staff structured this procurement as a task-authorization-based professional services contract. The proposed contract term is 36 months, with two optional one-year extensions at the City’s sole discretion. Specific project tasks would proceed only as directed through written authorizations issued by the City, allowing staff to direct work in increments as needed while maintaining flexibility as project scope, agency coordination, and funding opportunities continue to develop.

Project Status and Next Phase

The Re-Create 248 Transit Study and associated Alternatives Analysis established a preferred direction for corridor improvements connecting Quinn’s Junction, Bonanza Drive, SR-224/Deer Valley Drive, and the Old Town Transit Center. Public outreach completed during that phase, including onboard transit survey work and broader corridor engagement, helped confirm the need for faster and more reliable transit travel through this corridor. With the study phase substantially complete, the project is now transitioning from concept development into environmental review and design.

As the project moves into implementation, staff may also refine how the corridor is described publicly so that the name more clearly reflects the full project area from Quinn’s Junction to the Old Town Transit Center.

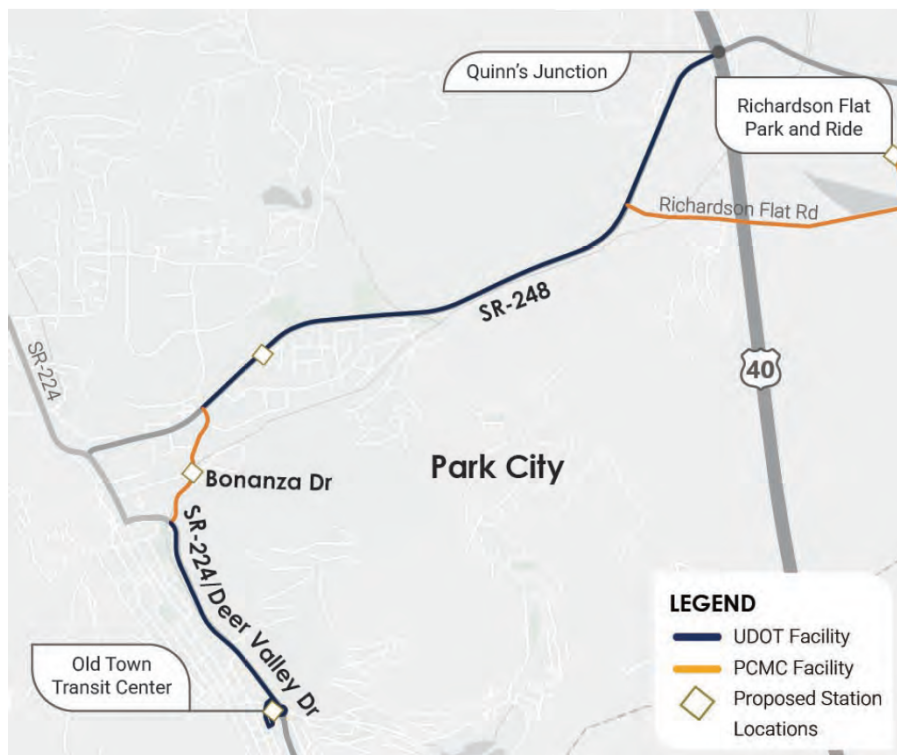

Figure 1: Study Area Map

Proposed Project Tasks

The consultant will be retained under a design professional contract with work authorizations issued at the City's direction. Rather than a single fixed scope, the contract is structured to allow the City to be nimble in authorizing work packages that respond to agency feedback, project needs, and funding opportunities. At this stage, the City has not yet determined the final federal environmental pathway for the project. Depending on scope, funding sources, and potential impacts, the project could proceed under a relatively streamlined NEPA process or require a more involved level of environmental documentation. That determination will affect both schedule and cost, since more complex environmental review requires additional technical analysis, agency coordination, documentation, and public involvement.

The general scope described in the RSOQ includes the following major work elements:

- **Project Management & Coordination:** Provide overall leadership, schedule control, budget tracking, decision logs, risk management, monthly reporting, and interagency coordination.
- **NEPA Strategy, Environmental Pathway Determination, and Scoping:** Determine the most appropriate federal environmental review pathway for the project
 - For example, whether it may qualify for a categorical exclusion or require a more detailed environmental document, and identify the technical studies, action limits, and approvals needed to advance the project.
- **Environmental Documentation:** Prepare the required environmental document and support technical analyses, coordinate agency review, and support the City through environmental clearance.
- **Action Limits and Segment Evaluation:** Assess whether specific project components, including the Richardson Flat Road segment and associated park-and-ride elements, should be included, phased, or omitted while avoiding segmentation risk.
- **Public Involvement and Property Owner Coordination:** Develop and implement an engagement strategy that includes public meetings, stakeholder outreach, and direct coordination with affected property owners.
- **Alternative Refinement and Design Development:** Continue refinement of the side-running transit lane concept, including the anticipated design footprint, evaluate cost-benefit tradeoffs of corridor improvements, and advance a preferred concept into preliminary engineering and final design as authorized.
- **ROW, Permitting, and Implementation Support:** Identify potential right-of-way needs, including temporary construction easements, access needs, and any limited property acquisition considerations if required; support permitting and utility coordination; and prepare implementation-ready plans, specifications, estimates, and procurement support materials for authorized elements.
- **Modeling, Grants, and Funding Strategy:** Provide STOPS and VISSIM modeling support, which opens up criteria for Federal grant competitiveness, prepare benefits documentation, and assist with grant strategy, grant writing, and state/federal funding coordination.
- **Optional Specialty Support:** Provide targeted technical support, including state-level government relations/project specific lobbyist coordination and specialty environmental or design services if project triggers are identified.

Comparable Projects

For context, consultant contracts for transit-priority corridors involving environmental clearance, engineering, and final design can vary significantly depending on corridor length, extent of dedicated running, right-of-way needs, utility conflicts, stakeholder coordination, and whether the scope includes only environmental review and preliminary engineering or extends through final design and implementation support. The comparisons below are provided to illustrate the scale of consultant effort often required for projects of this type; they are not direct apples-to-apples equivalents.

High Valley Transit's SR-224 BRT

Included environmental work contracted at approximately \$1.5 million in 2020, equivalent to roughly \$1.9 million in 2026 dollars. The actual cost for LPA refinement, Categorical Exclusion documentation, and preliminary engineering was approximately \$1.14 million, with about \$400,000 remaining because the project was originally scoped for an Environmental Assessment but was later determined by FTA to qualify for a Categorical Exclusion. Full engineering/design costs were reported at \$10.3 million base fee, plus \$600,000 in change orders to date, for a total of \$10.9 million.

Denver's East Colfax BRT (9.9 miles - 56% dedicated transit lanes)

Includes a partially dedicated operating plan with center-running dedicated bus-only lanes, curbside bus lanes, and mixed-flow segments. Denver amended its design contract to a total of \$24.1 million while advancing environmental review and design.

San Antonio's VIA Rapid Green Line (10.4 miles - 75% dedicated transit lanes)

Includes more than 75% dedicated transit lanes. The project received NEPA approval, and VIA later awarded a \$20 million final design contract. This is a strong dedicated-lane comparison, although the contract appears to be for final design after NEPA rather than a single combined NEPA-and-design contract.

Portland's TriMet Tualatin Valley Highway Transit & Safety Project (16.2 miles - priority treatments only)

Primarily a transit-priority corridor, rather than a fully dedicated bus-lane project. TriMet authorized a design services contract for up to \$17.25 million. This is a useful comparison for corridor design and implementation support, but it is not a fully dedicated BRT project.

These examples demonstrate that projects involving dedicated or partially dedicated transit lanes, environmental clearance, and advanced design often require consultant contracts well beyond the level of a typical planning study. Staff is not requesting authorization for the full potential program cost at this time. Instead, the current request is limited to the funding presently available in the project budget, with the expectation that staff will return to City Council for additional budget authority or contract amendments as later phases are authorized and additional grant or partner funding becomes available.

Funding

Staff is recommending approval of an initial contract amount of \$2.1 million, which reflects the funding currently available in the project budget. This funding is derived entirely from the Summit County Third Quarter Transportation Sales Tax program.

Staff does not anticipate that \$2.1 million will be sufficient to complete the full consultant scope contemplated under the RSOQ. Rather, this initial authorization is intended to begin priority work, including early environmental clearance activities, project definition, and initial engineering and design tasks.

Staff is actively pursuing additional Summit County Third Quarter Transportation Sales Tax funding, as well as state and federal grant opportunities. The City has also recently initiated a federal appropriation request through the Transportation, Housing and Urban Development (THUD) process. Depending on the amount and timing of additional funding, staff expects to return to City Council with a future budget request or contract amendment, potentially as early as July, to continue the remaining scope.

Action

Consider a request to authorize the City Manager to execute a Professional Services Agreement with Horrocks Engineers LLC, in a form approved by the City Attorney, in an initial amount not to exceed \$2,100,000, for environmental clearance, preliminary engineering, and final design support to advance the Re-Create 248 Transit Priority Project, with the understanding that additional funding requests, budget authority, and/or future contract amendments will be brought forward to complete later phases of work.

City Council Staff Report



Subject: FY27 Tentative Budget
Department: Budget Department
Date: May 7, 2026

Recommendation

Review, consider, and tentatively adopt the Tentative FY27 Budget for Park City Municipal Corporation and related agencies and authorize the property tax rate computation at a no-tax-increase rate (Exhibit A).

Executive Summary

The City is required to adopt a tentative budget on or before the first City Council meeting in May. The Council is also required to set a public hearing for budget adoption. Final Budget adoption is scheduled for June 11, 2026. Prior to adoption, Council and staff will continue evaluating projections and requests to refine the final FY27 budget.

Schedule:

- May 7 – Public hearing and Tentative Budget adoption
- May 21 – Follow-up presentations as needed
- June 4 – Follow-up presentations as needed
- June 11 – Public hearing and Final Budget and Fee Schedule adoption

Exhibits

Exhibit A: FY27 Tentative Budget Ordinance

Exhibit B: Budget Summaries



Ordinance No. 2026-12

**ORDINANCE ADOPTING A TENTATIVE BUDGET FOR FISCAL YEAR 2027 FOR
PARK CITY MUNICIPAL CORPORATION AND ITS RELATED AGENCIES AND
AUTHORIZING THE COMPUTATION OF THE PROPERTY TAX RATE AT A NO TAX
INCREASE RATE**

WHEREAS, the Utah State law requires that city budgets be adopted by the governing body;

NOW, THEREFORE, BE IT ORDAINED by the City Council of the City of Park City, Utah that:

SECTION 1. TENTATIVE BUDGET ADOPTED. The budget as outlined in the City Manager's Recommended budget presented on May 7, 2026, and with changes as summarized in the Attachments to this ordinance, is hereby adopted as the tentative budget for Fiscal Year 2027 for Park City Municipal Corporation and its related agencies.

SECTION 2. CERTIFIED PROPERTY TAX RATE. The City's Budget Officer is authorized, after the County has provided the Certified Property Tax data, to compute the City's Certified Property Tax Rate for 2027 at a "No Tax Increase Rate" and file said rate with the County.

SECTION 3. EFFECTIVE DATE. This Ordinance shall be effective on the day of publication.

PASSED AND ADOPTED this 7th day of May, 2026.

PARK CITY MUNICIPAL CORPORATION

Mayor Ryan Dickey

Attest:

Michelle Kellogg, City Recorder

APPROVED AS TO FORM:

City Attorney's Office

FY27 Revenue Projections - All Fund Combined

Revenue	FY23 Actuals	FY24 Actuals	FY25 Actuals	FY26 YTD	FY26 Original	FY27 Tentative
Property Tax	\$26,358,146.14	\$27,862,538.20	\$27,525,897.90	\$25,937,854.49	\$28,721,341.31	\$28,412,455.44
Sales Tax	\$51,529,732.49	\$52,859,211.31	\$53,868,715.19	\$29,986,783.47	\$55,499,373.80	\$54,593,714.91
Franchise Tax	\$4,368,710.08	\$4,096,926.40	\$3,840,404.60	\$2,640,279.60	\$4,236,908.86	\$4,159,035.83
Licenses	\$1,422,300.83	\$1,478,483.42	\$1,464,466.61	\$1,464,926.30	\$1,593,248.12	\$1,625,265.51
Planning Building & Engineering Fees	\$6,631,062.64	\$6,514,504.69	\$10,689,004.58	\$4,483,630.32	\$9,092,476.26	\$7,425,544.23
Special Event Fees	\$214,228.88	\$245,294.85	\$212,133.72	\$209,144.03	\$291,236.70	\$296,436.51
Federal Revenue	\$18,340,954.00	\$7,217,231.26	\$8,204,010.26	\$14,750,450.44	\$23,040,786.51	\$6,117,397.92
State Revenue	\$485,817.48	\$678,573.06	\$760,470.61	\$580,940.44	\$708,773.50	\$819,274.89
County/SP District Revenue	\$198,797.46	\$3,992,972.67	\$1,543,274.59	\$2,645,439.13	\$3,344,764.00	\$2,890,957.96
Water Charges for Services	\$22,538,674.56	\$25,851,893.82	\$29,570,271.28	\$23,256,240.48	\$28,884,367.66	\$30,127,751.52
Transit Charges for Services	\$33,378.62	\$313,392.07	\$801,146.02	-\$163,640.82	\$300,000.00	\$330,000.00
Cemetery Charges for Services	\$20,057.00	\$31,488.00	\$15,578.00	\$13,383.00	\$54,660.00	\$37,893.98
Recreation	\$4,672,031.57	\$4,974,558.55	\$5,700,036.26	\$3,984,183.79	\$5,871,383.46	\$6,248,390.68
Ice	\$945,775.05	\$1,059,280.11	\$1,172,479.54	\$906,465.07	\$1,109,407.46	\$1,133,307.46
Other Service Revenue	\$73,703.72	\$78,756.49	\$80,768.91	\$53,116.49	\$138,230.47	\$114,216.18
Library Fees	\$14,615.20	\$18,877.32	\$18,937.40	\$15,408.61	\$20,488.00	\$21,448.57
Fines & Forfeitures	\$2,768,712.05	\$2,901,116.13	\$2,583,352.03	\$3,104,802.72	\$3,082,762.24	\$2,562,360.71
Misc. Revenues	\$12,389,850.46	\$13,646,851.45	\$16,855,418.32	\$3,882,104.83	\$11,166,872.06	\$11,525,980.25
Interfund Transactions (Admin)	\$8,478,974.00	\$9,039,648.00	\$9,018,871.00	\$7,478,086.00	\$9,209,711.00	\$7,777,804.83
Interfund Transactions (CIP/Debt)	\$15,025,910.00	\$14,635,145.00	\$13,361,439.00	\$10,961,258.00	\$11,957,747.00	\$25,000.00
Special Revenues & Resources	\$1,976,567.37	\$854,512.08	\$2,255,458.35	\$1,927,417.65	\$948,441.70	\$994,699.57
Bond Proceeds	\$0.00	\$0.00	\$0.00	\$0.00	\$30,000,000.00	\$35,000,000.00
Total	\$178,487,999.60	\$178,351,254.88	\$189,542,134.17	\$138,118,274.04	\$229,272,980.11	\$202,238,936.95

NEXT YEAR BUDGET HISTORICAL COMPARISON

PROJECTION: 20276 Tentative Budget - Full Upload FOR PERIOD 99

ACCOUNTS FOR:

General Fund	PRIOR FY3 ACTUALS	PRIOR FY2 ACTUALS	LAST FY1 ACTUALS	CY ACTUALS	CY REV BUDGET	PROJECTION LEVEL 4	PCT CHANGE
Salaries & Benefits	30,064,878.24	33,471,008.61	35,779,108.06	31,411,202.44	39,515,491.48	40,173,422.12	1.7%
Supplies, Main & Srv	9,267,716.97	10,160,886.07	10,928,505.72	8,247,283.90	11,994,841.23	11,225,208.43	-6.4%
Energy & Utilities	1,668,302.84	2,036,792.42	1,938,394.79	613,239.12	2,015,064.00	2,006,359.00	-.4%
Capital Outlay	1,024,898.37	622,551.23	185,725.46	346,964.16	539,467.00	464,467.00	-13.9%
Transfers Out	5,837,880.00	4,131,457.00	4,011,649.00	3,734,412.00	4,073,905.00	3,963,396.40	-2.7%
TOTAL General Fund	47,863,676.42	50,422,695.33	52,843,383.03	44,353,101.62	58,138,768.71	57,832,852.95	-.5%

NEXT YEAR BUDGET HISTORICAL COMPARISON

PROJECTION: 20276 Tentative Budget - Full Upload							FOR PERIOD 99
ACCOUNTS FOR:							
Quinns Recreation Complex	PRIOR FY3 ACTUALS	PRIOR FY2 ACTUALS	LAST FY1 ACTUALS	CY ACTUALS	CY REV BUDGET	PROJECTION LEVEL 4	PCT CHANGE
Salaries & Benefits	1,088,539.44	1,152,504.76	1,114,051.79	930,906.31	1,365,452.15	1,379,417.10	1.0%
Supplies, Main & Srv	213,086.51	242,835.00	274,973.04	215,411.27	340,395.00	340,528.00	.0%
Energy & Utilities	166,732.78	164,292.81	166,491.65	117,029.13	162,759.00	171,147.00	5.2%
Capital Outlay	.00	.00	.00	.00	5,000.00	1,000.00	-80.0%
TOTAL Quinns Recreation Comp	1,468,358.73	1,559,632.57	1,555,516.48	1,263,346.71	1,873,606.15	1,892,092.10	1.0%

NEXT YEAR BUDGET HISTORICAL COMPARISON

PROJECTION: 20276 Tentative Budget - Full Upload							FOR PERIOD 99	
ACCOUNTS FOR:								
Police Special Revenue Fund	PRIOR FY3 ACTUALS	PRIOR FY2 ACTUALS	LAST FY1 ACTUALS	CY ACTUALS	CY REV BUDGET	PROJECTION LEVEL 4	PCT CHANGE	
Capital Outlay	.00	.00	.00	.00	.00	.00	.00	.0%
TOTAL Police Special Revenue	.00	.00	.00	.00	.00	.00	.00	.0%

NEXT YEAR BUDGET HISTORICAL COMPARISON

PROJECTION: 20276 Tentative Budget - Full Upload						FOR PERIOD 99	
ACCOUNTS FOR:							
Criminal Forfeiture	PRIOR FY3 ACTUALS	PRIOR FY2 ACTUALS	LAST FY1 ACTUALS	CY ACTUALS	CY REV BUDGET	PROJECTION LEVEL 4	PCT CHANGE
Capital Outlay	3,021.14	11,955.48	31,689.05	.00	.00	.00	.0%
TOTAL Criminal Forfeiture	3,021.14	11,955.48	31,689.05	.00	.00	.00	.0%

NEXT YEAR BUDGET HISTORICAL COMPARISON

PROJECTION: 20276 Tentative Budget - Full Upload							FOR PERIOD 99	
ACCOUNTS FOR:								
Lower Park Ave RDA Special Rev	PRIOR FY3 ACTUALS	PRIOR FY2 ACTUALS	LAST FY1 ACTUALS	CY ACTUALS	CY REV BUDGET	PROJECTION LEVEL 4	PCT CHANGE	
Supplies, Main & srv	705,337.42	737,665.14	863,759.36	.00	830,000.00	830,000.00	.0%	
Energy & Utilities	2,977.99	5,430.46	2,278.68	-27.42	5,823.00	5,823.00	.0%	
Transfers Out	3,092,532.00	3,092,532.00	3,092,532.00	2,834,821.00	3,092,532.00	3,092,532.00	.0%	
TOTAL Lower Park Ave RDA Spe	3,800,847.41	3,835,627.60	3,958,570.04	2,834,793.58	3,928,355.00	3,928,355.00	.0%	

NEXT YEAR BUDGET HISTORICAL COMPARISON

PROJECTION: 20276 Tentative Budget - Full Upload						FOR PERIOD 99	
ACCOUNTS FOR:							
Main Street RDA Special Rev	PRIOR FY3 ACTUALS	PRIOR FY2 ACTUALS	LAST FY1 ACTUALS	CY ACTUALS	CY REV BUDGET	PROJECTION LEVEL 4	PCT CHANGE
Supplies, Main & srv	236,992.72	30,000.00	7,300.00	.00	50,000.00	50,000.00	.0%
Transfers out	400,000.00	.00	.00	.00	.00	.00	.0%
TOTAL Main Street RDA Special	636,992.72	30,000.00	7,300.00	.00	50,000.00	50,000.00	.0%

NEXT YEAR BUDGET HISTORICAL COMPARISON

PROJECTION: 20276 Tentative Budget - Full Upload FOR PERIOD 99

ACCOUNTS FOR:

Capital Improvement Fund	PRIOR FY3 ACTUALS	PRIOR FY2 ACTUALS	LAST FY1 ACTUALS	CY ACTUALS	CY REV BUDGET	PROJECTION LEVEL 4	PCT CHANGE
Transfers Out	4,177,076.00	4,174,476.00	4,176,426.00	3,827,109.00	4,175,025.00	4,175,025.00	.0%
TOTAL Capital Improvement Fu	4,177,076.00	4,174,476.00	4,176,426.00	3,827,109.00	4,175,025.00	4,175,025.00	.0%

NEXT YEAR BUDGET HISTORICAL COMPARISON

PROJECTION: 20276 Tentative Budget - Full Upload							FOR PERIOD 99	
ACCOUNTS FOR:								
Lower Park Ave RDA Capital Fnd	PRIOR FY3 ACTUALS	PRIOR FY2 ACTUALS	LAST FY1 ACTUALS	CY ACTUALS	CY REV BUDGET	PROJECTION LEVEL 4	PCT CHANGE	
Transfers Out	2,791,715.00	2,790,840.00	2,790,840.00	2,547,952.00	2,779,590.00	2,779,590.00	.0%	
TOTAL Lower Park Ave RDA Cap	2,791,715.00	2,790,840.00	2,790,840.00	2,547,952.00	2,779,590.00	2,779,590.00	.0%	

City of Park City

NEXT YEAR BUDGET HISTORICAL COMPARISON

PROJECTION: 20276 Tentative Budget - Full Upload						FOR PERIOD 99	
ACCOUNTS FOR:							
Water Fund	PRIOR FY3 ACTUALS	PRIOR FY2 ACTUALS	LAST FY1 ACTUALS	CY ACTUALS	CY REV BUDGET	PROJECTION LEVEL 4	PCT CHANGE
Salaries & Benefits	4,294,070.20	5,197,401.36	5,554,355.02	4,431,088.31	5,185,227.92	5,251,565.49	1.3%
Supplies, Main & Srv	3,970,583.33	5,514,037.54	4,979,561.44	3,093,945.47	5,979,408.99	6,276,898.29	5.0%
Energy & Utilities	856,673.65	843,258.28	742,050.62	539,742.21	1,142,600.00	1,142,600.00	.0%
Depreciation & Amort	4,196,690.00	4,571,070.00	6,341,039.67	.00	.00	.00	.0%
Debt Service	3,800,727.36	3,596,416.57	3,470,486.36	5,500,707.13	9,405,237.00	9,405,237.00	.0%
Capital Outlay	-18,858,516.81	-13,252,756.79	-3,771,422.92	2,601.73	43,000.00	43,000.00	.0%
Transfers Out	2,090,991.00	2,584,649.00	2,639,983.00	1,532,157.00	2,723,253.00	2,524,276.42	-7.3%
TOTAL Water Fund	351,218.73	9,054,075.96	19,956,053.19	15,100,241.85	24,478,726.91	24,643,577.20	.7%

Report generated: 05/05/2026 08:18
 User: hjasperson
 Program ID: bgnyrpts

City of Park City

NEXT YEAR BUDGET HISTORICAL COMPARISON

PROJECTION: 20276 Tentative Budget - Full Upload						FOR PERIOD 99	
ACCOUNTS FOR:							
Stormwater Fund	PRIOR FY3 ACTUALS	PRIOR FY2 ACTUALS	LAST FY1 ACTUALS	CY ACTUALS	CY REV BUDGET	PROJECTION LEVEL 4	PCT CHANGE
Salaries & Benefits	660,125.52	589,934.22	723,562.61	512,584.68	893,844.65	905,833.22	1.3%
Supplies, Main & Srv	103,299.60	117,926.78	222,849.95	47,185.74	254,531.00	254,531.00	.0%
Energy & Utilities	36,788.13	45,452.42	33,665.18	22,914.86	46,099.00	46,099.00	.0%
Depreciation & Amort	173,616.00	506,285.00	185,808.02	.00	.00	.00	.0%
Capital Outlay	-18,831.00	-415,907.71	-32,619.00	.00	1,500.00	1,500.00	.0%
Transfers Out	164,627.00	173,153.00	195,018.00	185,515.00	202,395.00	144,157.01	-28.8%
TOTAL Stormwater Fund	1,119,625.25	1,016,843.71	1,328,284.76	768,200.28	1,398,369.65	1,352,120.23	-3.3%

Report generated: 05/05/2026 08:18
 User: hjasperson
 Program ID: bgnyrpts

NEXT YEAR BUDGET HISTORICAL COMPARISON

PROJECTION: 20276 Tentative Budget - Full Upload FOR PERIOD 99

ACCOUNTS FOR:

Golf Course Fund	PRIOR FY3 ACTUALS	PRIOR FY2 ACTUALS	LAST FY1 ACTUALS	CY ACTUALS	CY REV BUDGET	PROJECTION LEVEL 4	PCT CHANGE
Salaries & Benefits	872,417.79	1,026,267.81	1,188,500.53	901,550.61	1,353,392.10	1,363,863.44	.8%
Supplies, Main & Srv	483,140.00	506,779.03	633,485.20	532,715.25	722,825.00	762,825.00	5.5%
Energy & Utilities	40,408.41	39,272.46	48,002.43	21,282.03	61,600.00	63,241.00	2.7%
Depreciation & Amort	210,152.00	211,656.00	226,992.02	.00	.00	.00	.0%
Capital Outlay	-195,546.00	-18,921.00	-258,299.00	555,166.22	65,505.00	65,505.00	.0%
Transfers Out	171,353.00	186,195.00	204,623.00	195,349.00	213,098.00	254,408.59	19.4%
TOTAL Golf Course Fund	1,581,925.20	1,951,249.30	2,043,304.18	2,206,063.11	2,416,420.10	2,509,843.03	3.9%

NEXT YEAR BUDGET HISTORICAL COMPARISON

PROJECTION: 20276 Tentative Budget - Full Upload FOR PERIOD 99

ACCOUNTS FOR:

Transportation Fund	PRIOR FY3 ACTUALS	PRIOR FY2 ACTUALS	LAST FY1 ACTUALS	CY ACTUALS	CY REV BUDGET	PROJECTION LEVEL 4	PCT CHANGE
Salaries & Benefits	9,885,010.69	12,521,760.40	14,035,303.20	12,722,436.28	13,792,768.71	14,017,930.09	1.6%
Supplies, Main & Srv	2,263,340.42	3,052,314.38	2,301,598.26	1,396,771.09	2,100,814.28	2,082,065.72	-.9%
Energy & Utilities	348,694.51	377,362.38	275,643.87	260,569.12	319,862.00	431,255.30	34.8%
Depreciation & Amort	2,737,965.00	3,391,461.00	3,269,453.77	.00	.00	.00	.0%
Capital Outlay	-7,766,000.10	-5,333,929.36	-3,611,980.98	422,563.02	425,934.00	425,934.00	.0%
Transfers Out	3,756,742.00	3,742,831.00	3,693,665.00	3,406,183.00	3,715,829.00	3,640,351.51	-2.0%
TOTAL Transportation Fund	11,225,752.52	17,751,799.80	19,963,683.12	18,208,522.51	20,355,207.99	20,597,536.62	1.2%

City of Park City

NEXT YEAR BUDGET HISTORICAL COMPARISON

PROJECTION: 20276 Tentative Budget - Full Upload						FOR PERIOD 99	
ACCOUNTS FOR:							
Parking Fund	PRIOR FY3 ACTUALS	PRIOR FY2 ACTUALS	LAST FY1 ACTUALS	CY ACTUALS	CY REV BUDGET	PROJECTION LEVEL 4	PCT CHANGE
Salaries & Benefits	1,007,836.40	1,358,390.32	1,545,311.84	1,262,336.66	1,531,342.51	1,559,846.35	1.9%
Supplies, Main & Srv	492,733.80	664,244.92	732,070.47	380,285.63	692,800.00	796,800.00	15.0%
Energy & Utilities	17,985.05	16,268.79	8,619.76	13,601.28	11,400.00	12,613.00	10.6%
Depreciation & Amort	35,555.00	40,806.00	200,621.31	.00	.00	.00	.0%
Capital Outlay	-65,986.38	-110,466.00	-82,359.00	.00	.00	.00	.0%
Transfers Out	67,981.00	131,963.00	184,533.00	175,846.00	191,831.00	213,624.90	11.4%
TOTAL Parking Fund	1,556,104.87	2,101,207.03	2,588,797.38	1,832,069.57	2,427,373.51	2,582,884.25	6.4%

Report generated: 05/05/2026 08:18
 User: hjasperson
 Program ID: bgnyrpts

NEXT YEAR BUDGET HISTORICAL COMPARISON

PROJECTION: 20276 Tentative Budget - Full Upload							FOR PERIOD 99
ACCOUNTS FOR:							
Fleet Services Fund	PRIOR FY3 ACTUALS	PRIOR FY2 ACTUALS	LAST FY1 ACTUALS	CY ACTUALS	CY REV BUDGET	PROJECTION LEVEL 4	PCT CHANGE
Salaries & Benefits	1,235,024.46	1,322,835.12	1,501,552.42	1,200,113.76	1,675,151.76	1,698,079.61	1.4%
Supplies, Main & Srv	1,044,961.81	661,718.17	843,639.90	588,020.73	1,321,550.00	1,321,550.00	.0%
Energy & Utilities	1,110,353.61	845,042.58	796,293.72	637,065.93	1,077,900.00	1,077,900.00	.0%
Capital Outlay	4,695.08	.00	1,428.95	.00	6,205.00	6,205.00	.0%
TOTAL Fleet Services Fund	3,395,034.96	2,829,595.87	3,142,914.99	2,425,200.42	4,080,806.76	4,103,734.61	.6%

NEXT YEAR BUDGET HISTORICAL COMPARISON

PROJECTION: 20276 Tentative Budget - Full Upload FOR PERIOD 99

ACCOUNTS FOR:

Self Insurance Fund	PRIOR FY3 ACTUALS	PRIOR FY2 ACTUALS	LAST FY1 ACTUALS	CY ACTUALS	CY REV BUDGET	PROJECTION LEVEL 4	PCT CHANGE
Supplies, Main & Srv	2,116,254.81	1,856,697.09	2,355,681.25	1,871,948.29	2,805,402.00	2,855,402.00	1.8%
TOTAL Self Insurance Fund	2,116,254.81	1,856,697.09	2,355,681.25	1,871,948.29	2,805,402.00	2,855,402.00	1.8%

City of Park City

NEXT YEAR BUDGET HISTORICAL COMPARISON

PROJECTION: 20276 Tentative Budget - Full Upload							FOR PERIOD 99	
ACCOUNTS FOR:								
Sales Tax Rev Bond Dbt Service	PRIOR FY3 ACTUALS	PRIOR FY2 ACTUALS	LAST FY1 ACTUALS	CY ACTUALS	CY REV BUDGET	PROJECTION LEVEL 4	PCT CHANGE	
Debt Service	6,971,475.00	7,510,945.00	6,959,548.99	2,479,015.50	6,964,616.00	6,964,616.00	.0%	
Transfers Out	953,987.00	2,666,697.00	650,280.00	.00	.00	.00	.0%	
TOTAL Sales Tax Rev Bond Dbt	7,925,462.00	10,177,642.00	7,609,828.99	2,479,015.50	6,964,616.00	6,964,616.00	.0%	

Report generated: 05/05/2026 08:18
 User: hjasperson
 Program ID: bgnyrpts

City of Park City

NEXT YEAR BUDGET HISTORICAL COMPARISON

PROJECTION: 20276 Tentative Budget - Full Upload							FOR PERIOD 99	
ACCOUNTS FOR:								
GO Bond Debt Service	PRIOR FY3 ACTUALS	PRIOR FY2 ACTUALS	LAST FY1 ACTUALS	CY ACTUALS	CY REV BUDGET	PROJECTION LEVEL 4	PCT CHANGE	
Debt Service	9,487,976.50	9,476,925.42	8,422,062.92	6,314,803.42	7,162,376.00	7,162,376.00	.0%	
TOTAL GO Bond Debt Service	9,487,976.50	9,476,925.42	8,422,062.92	6,314,803.42	7,162,376.00	7,162,376.00	.0%	
GRAND TOTAL	99,501,042.26	119,041,263.16	132,774,335.38	106,032,367.86	143,034,643.78	143,430,004.99	.3%	

** END OF REPORT - Generated by Hans Jaspersen **

Report generated: 05/05/2026 08:18
 User: hjasperson
 Program ID: bgnyrpts

Page 17



City Council Staff Report

Subject: Quit Claim of Park City Property to UDOT
Author: Steven Dennis PE, PMP
Department: Engineering
Date: May 7, 2026

Recommendation

Authorize the Mayor to execute a quit claim deed, in a form approved by the City Attorney’s Office, transferring ownership of a parcel of land residing within the Marsac roundabout to the Utah Department of Transportation (UDOT).

Executive Summary

In October 2025, UDOT submitted an unsolicited request to acquire approximately 19,900 square feet (0.48 acres) of property owned by Park City Municipal Corporation (PCMC) and the Park City Redevelopment Agency (RDA) surrounding the Marsac roundabout on SR-224.

The request is not tied to a specific project, but rather to clarify ownership of land underlying a state-controlled roadway to minimize liability and risk for Park City. Staff recommends proceeding with the action to convey the requested property to UDOT to streamline maintenance operations, align ownership with control, and reduce potential liability exposure.

Analysis

Although PCMC retains title to portions of the land, UDOT controls and operates the roadway. The split ownership creates administrative and legal inefficiencies:

- UDOT must obtain permits from PCMC to perform maintenance activities.
- PCMC has been named in litigation related to vehicular accidents occurring on a state-controlled roadway due to underlying land ownership.

The parcels have no independent development potential and provide no practical benefit to PCMC, as they are fully within the SR-224 roadway footprint. UDOT already has full control of this portion of SR-224.

Conveying the property would not change roadway operations, but would:

- Streamline maintenance and capital improvements
- Align ownership with operational control
- Reduce potential liability exposure for PCMC

Parcel ID	Owner	Current Size	Requested Portion
PC-476-F-X / PC-476-H-X / PC-476-B-1-A-X	PCMC	22,603 sf (0.52 ac)	6,877 sf (0.16 ac)

Funding

Staff recommends that the PCMC convey the property to UDOT for \$10.00. UDOT will cover all third-party costs associated with preparing and executing the quit claim deed.

Exhibits

- A. Requested Area

EXHIBIT A
Requested Area

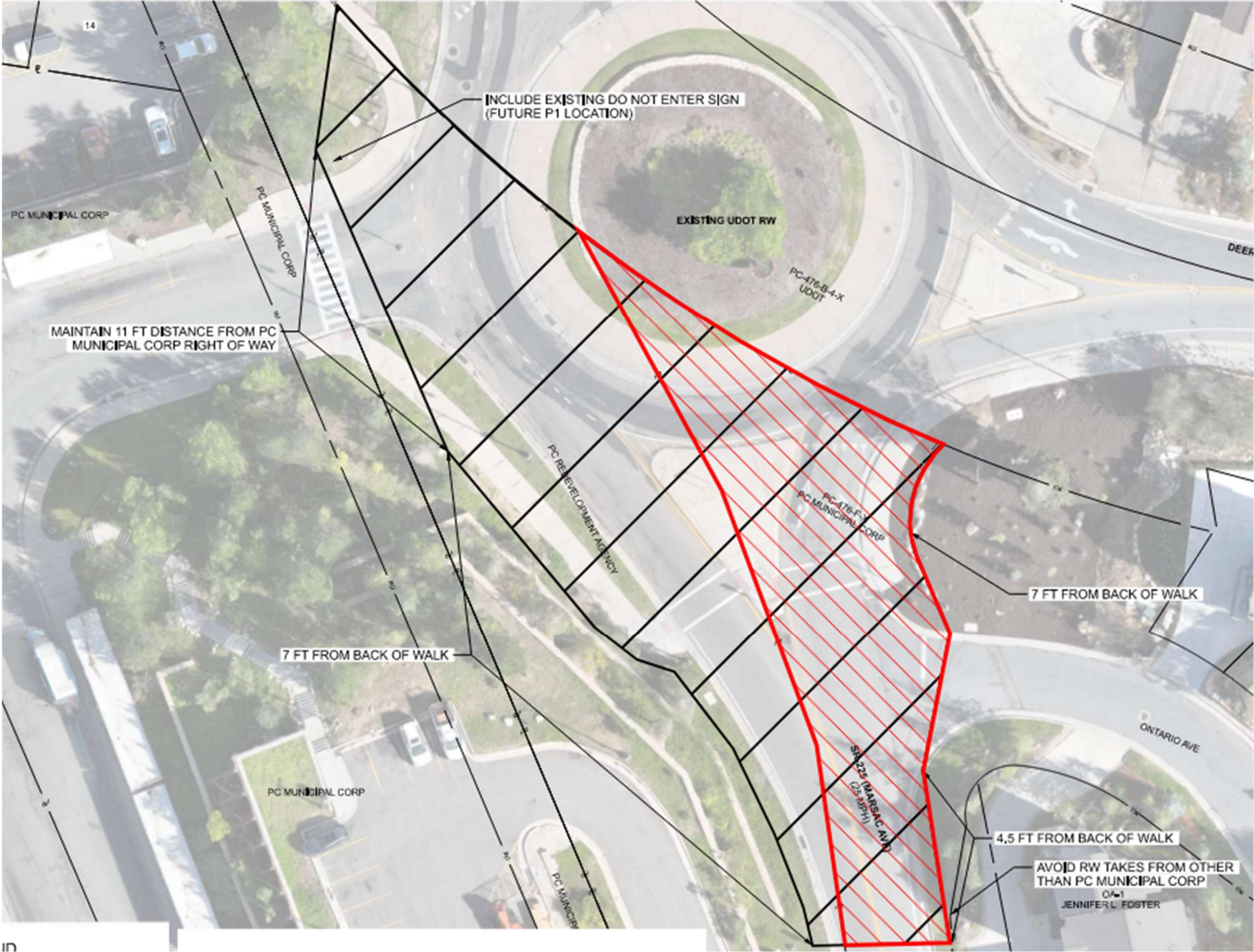

IN



Redevelopment Agency Staff Report

Subject: Grant of Easements by the Park City Redevelopment Agency for Transit Improvements and Operation
Author: Steven Dennis PE, PMP
Sydney Maves
Department: Engineering & Transportation Planning
Date: May 7, 2026

Recommendation

Authorize the Chair of the Park City Redevelopment Agency (RDA) to execute temporary construction easements (TCEs) and perpetual easements (PEs), in forms approved by the City Attorney's Office, granting Park City Municipal Corporation non-exclusive rights to construct, operate, and maintain bus stops and related improvements on RDA-owned property.

Executive Summary

The Bus Stop Improvement Project (Project) includes improvements to two bus stops and one intersection that affect RDA-owned property. These improvements are intended to enhance public transit access and pedestrian safety and support the City's ongoing efforts to provide safe, comfortable, and reliable alternatives to private vehicle use.

The Project is primarily funded through grants. To satisfy grant requirements and allow construction to proceed, the RDA must grant temporary and perpetual construction easements to the City for the affected areas. Granting these easements will allow the City to use external funding to complete the Project while maintaining public control of the property.

Analysis

The City requires TCEs and PEs from the RDA to complete bus stop and intersection safety improvements included in Phases 2 and 3 of the Project. The affected bus stops are existing stops located on RDA-owned property; however, staff could not locate any prior easement or formal agreement authorizing their use. Because the Project includes federal funding, the City must establish permanent property rights for the improvements.

The proposed improvements affect the following locations:

Park Avenue and Sullivan Road Intersection

The proposed improvements narrow the roadway and tighten curb radii to reduce vehicle speeds in a high-pedestrian area. This work affects RDA parcel SA-369-X.

Library East (Stop ID 1250)

The proposed improvements will relocate this stop farther south onto RDA parcels SA-372-X, SA-371-X, and SA-370-X to create a more cohesive pedestrian connection between the anticipated Senior Center and the Library.

Police Station (Stop ID 10080)

The proposed improvements will relocate this stop farther north within the RDA parcel SCCS-9-9B-1-X to increase separation from the SR-224 and Snow Creek Drive intersection. This additional distance will provide more space for transit operators to navigate safely through queued vehicles.

Granting these easements will provide a significant public benefit by allowing the Project to leverage federal funding to complete the improvements, with little practical effect on long-term public land control, as the City Council serves as the governing body for both the City and the RDA.

Parcel	Parcel Size	PE Size	TCE Size
SA-369-X	5,663 sf	0 sf	606 sf
SA-370-X	14,810 sf	103 sf	0 sf
SA-371-X	5,663 sf	145 sf	915 sf
SA-372-X	12,197 sf	229 sf	1,242 sf
SCCS-9-9B-1-X	237,838 sf	161 sf	278 sf
Total Size of Easements		638 sf	3,041 sf

Funding

Staff recommends that the RDA donate the easements to the City to avoid adding cost to the Project. A market study estimated the fair market value of the easements at \$4,839.76. Donating the easements will help preserve available project funding for the construction of the transit and safety improvements rather than land acquisition costs.

Exhibits

- A. Park Ave and Sullivan Rd Intersection
- B. Library East
- C. Police Station

EXHIBIT A
Park Avenue and Sullivan Rd Intersection

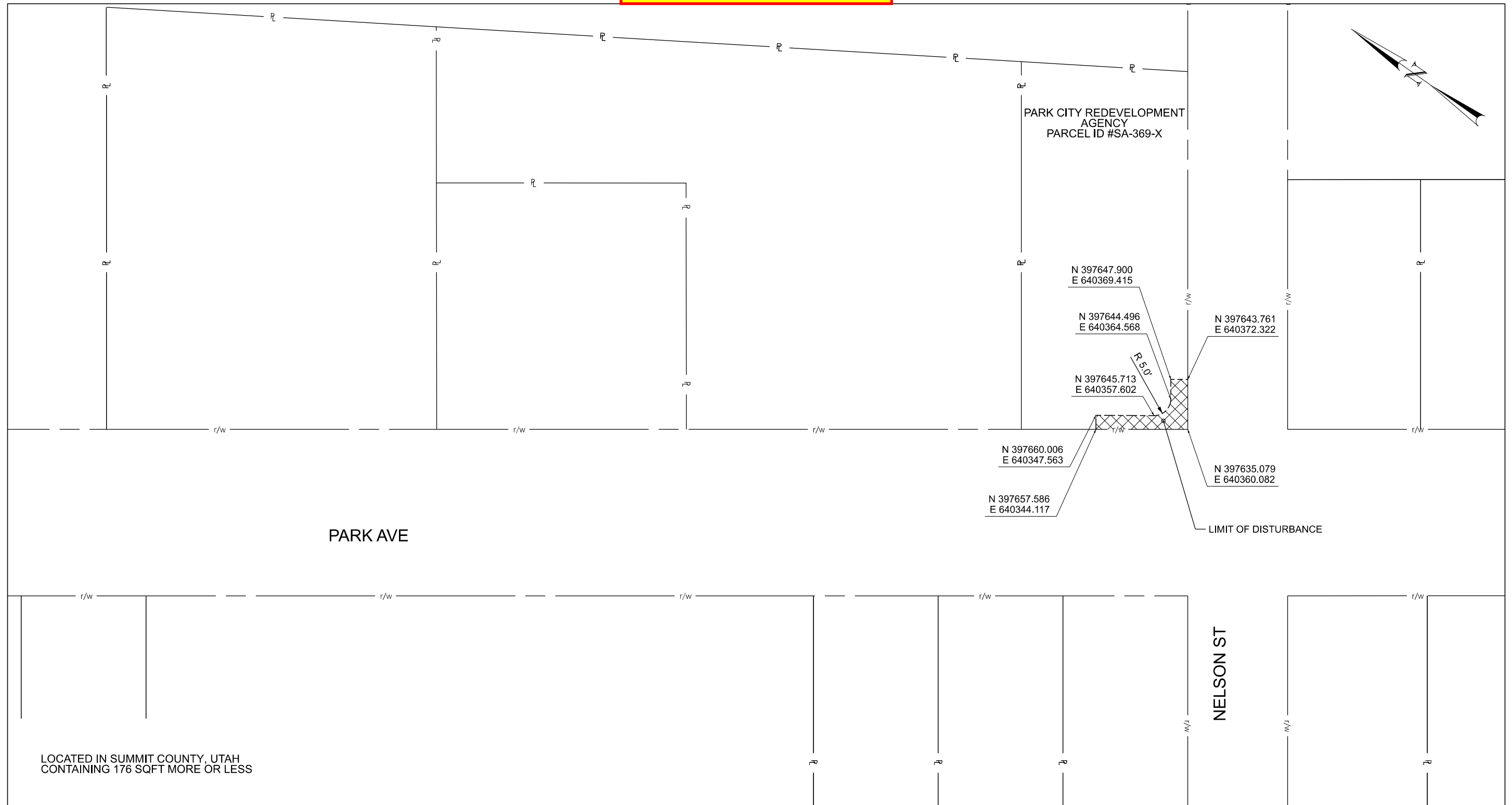

PARK AVE

NELSON ST

LOCATED IN SUMMIT COUNTY, UTAH
CONTAINING 176 SQFT MORE OR LESS

PROJECT	PARK CITY BUS STOP PROGRAM	Scale (Feet) 	RIGHT-OF-WAY PARK CITY MUNICIPAL CORPORATION KIMLEY-HORN	PROPERTY OWNER:	PARK CITY REDEVELOPMENT AGENCY
PROJECT NUMBER	PROJECT NUMBER CP0025		PROPERTY ADDRESS:	PARK AVE	

EXHIBIT B
Library East

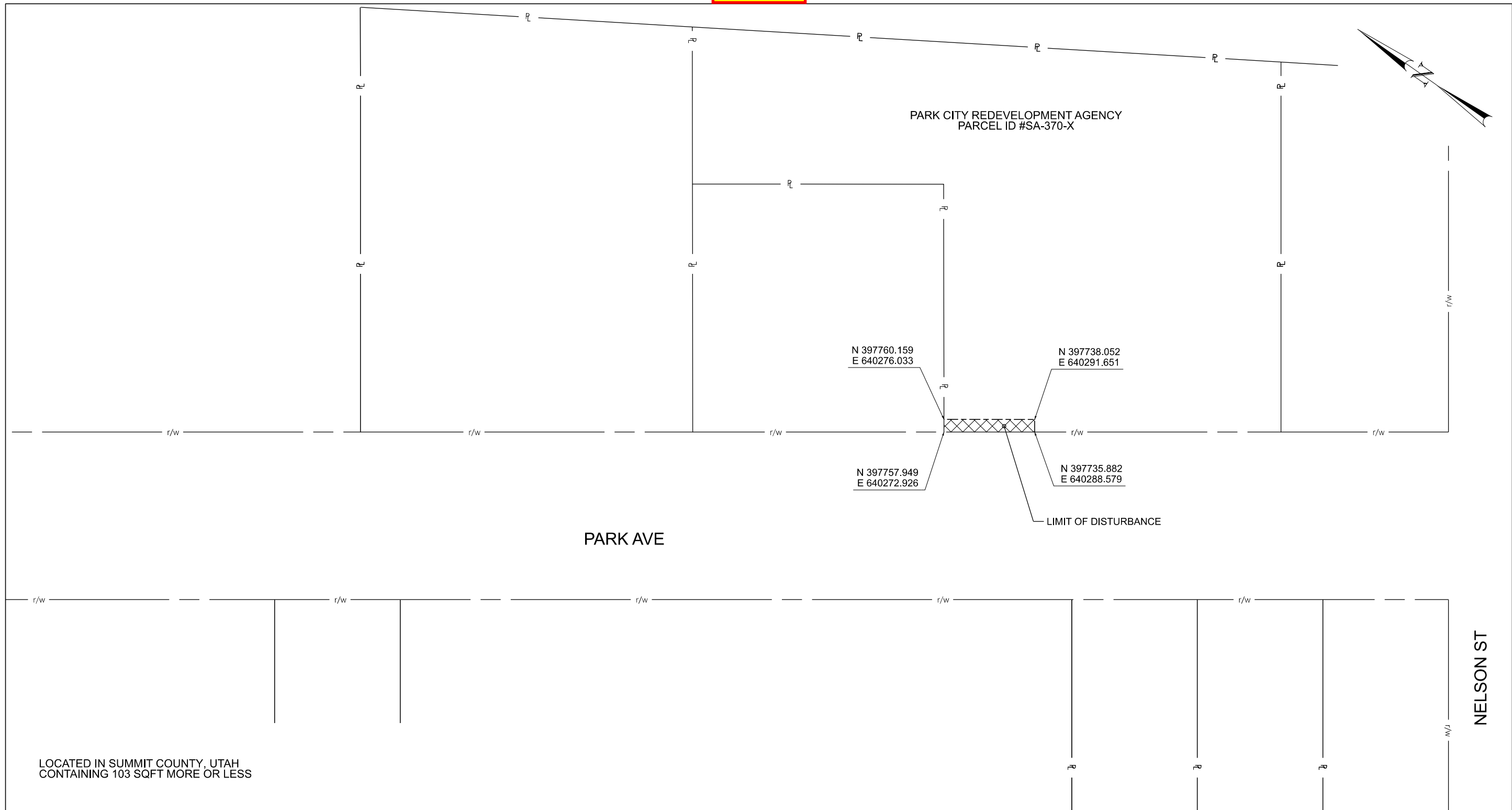

PROJECT	PARK CITY BUS STOP PROGRAM	<p>Scale (Feet)</p>	<p>RIGHT-OF-WAY PARK CITY MUNICIPAL CORPORATION KIMLEY-HORN</p>	PROPERTY OWNER: PARK CITY REDEVELOPMENT AGENCY
	PROJECT NUMBER CP0025			PROPERTY ADDRESS: 1220 PARK AVE

EXHIBIT B
Library East

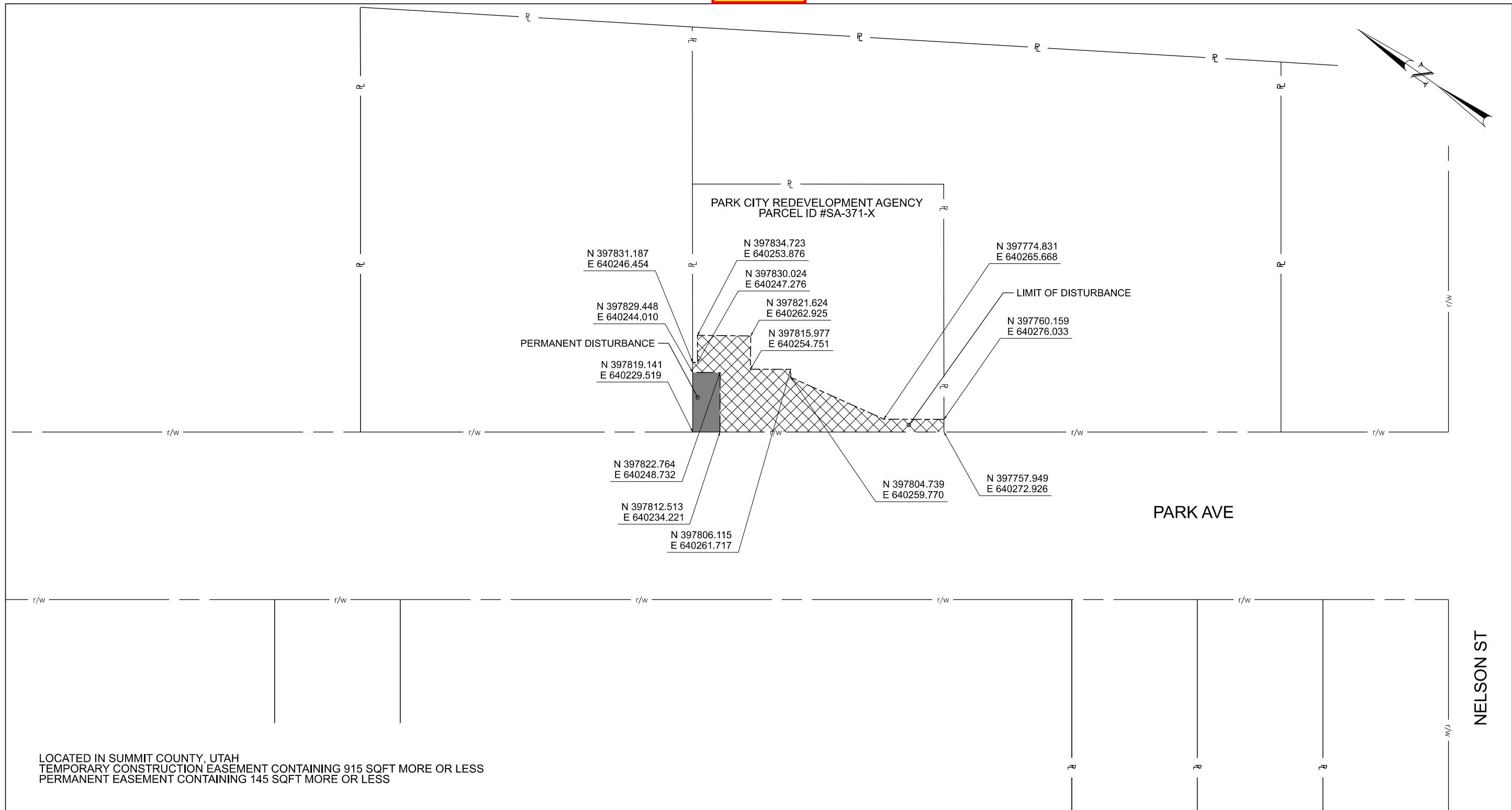

PROJECT	PARK CITY BUS STOP PROGRAM	<p>Scale (Feet)</p>	<p>RIGHT-OF-WAY PARK CITY MUNICIPAL CORPORATION KIMLEY-HORN</p>	PROPERTY OWNER:	PARK CITY REDEVELOPMENT AGENCY
PROJECT NUMBER	PROJECT NUMBER CP0025			PROPERTY ADDRESS:	1240 PARK AVE

EXHIBIT B
Library East

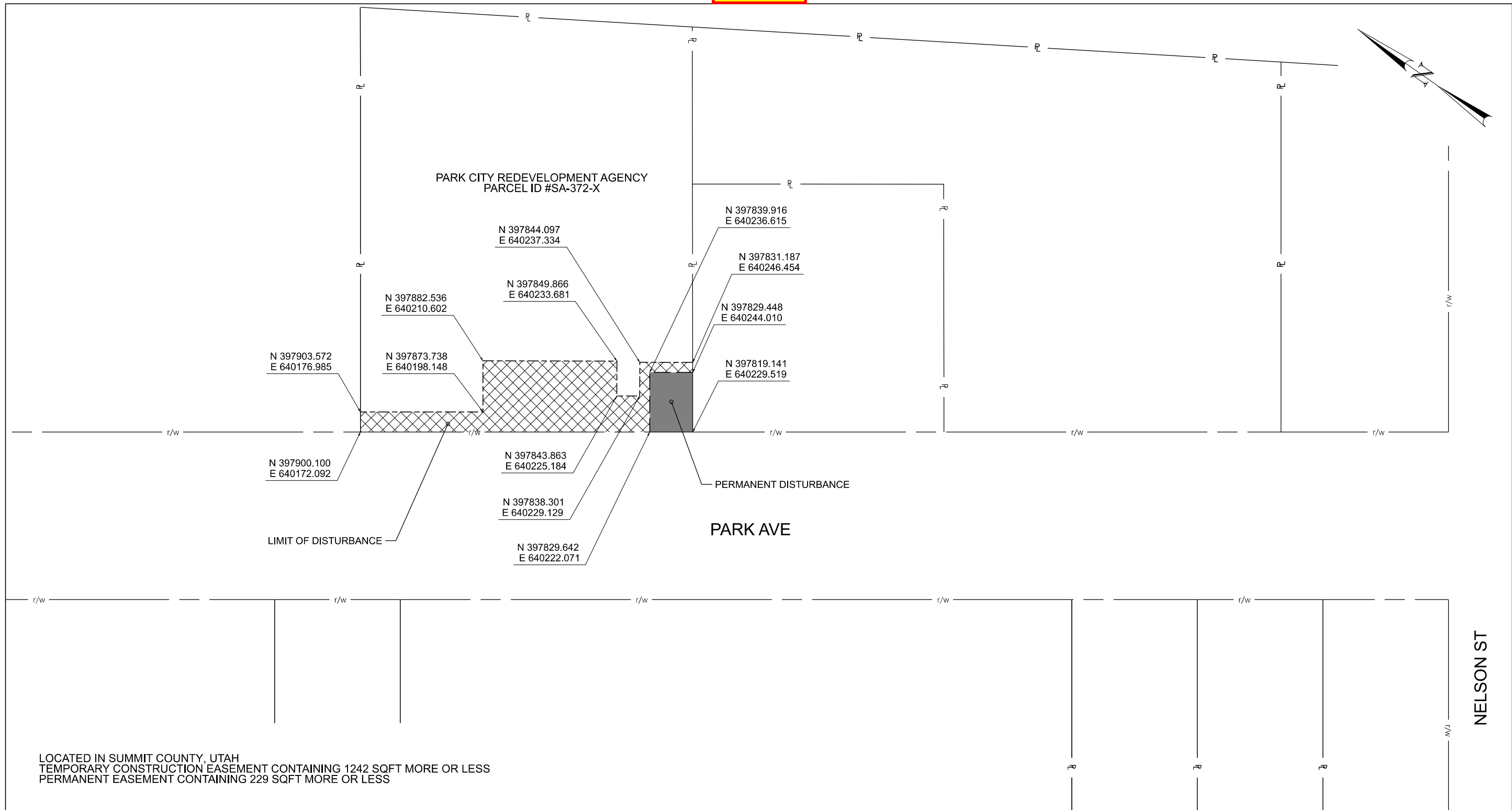

PROJECT	PARK CITY BUS STOP PROGRAM	<p>Scale (Feet)</p>	<p>RIGHT-OF-WAY PARK CITY MUNICIPAL CORPORATION KIMLEY-HORN</p>	PROPERTY OWNER: PARK CITY REDEVELOPMENT AGENCY
	PROJECT NUMBER CP0025			PROPERTY ADDRESS: 1260 PARK AVE

EXHIBIT C
Police Station

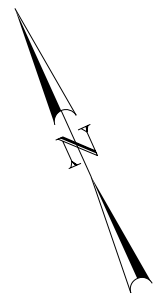
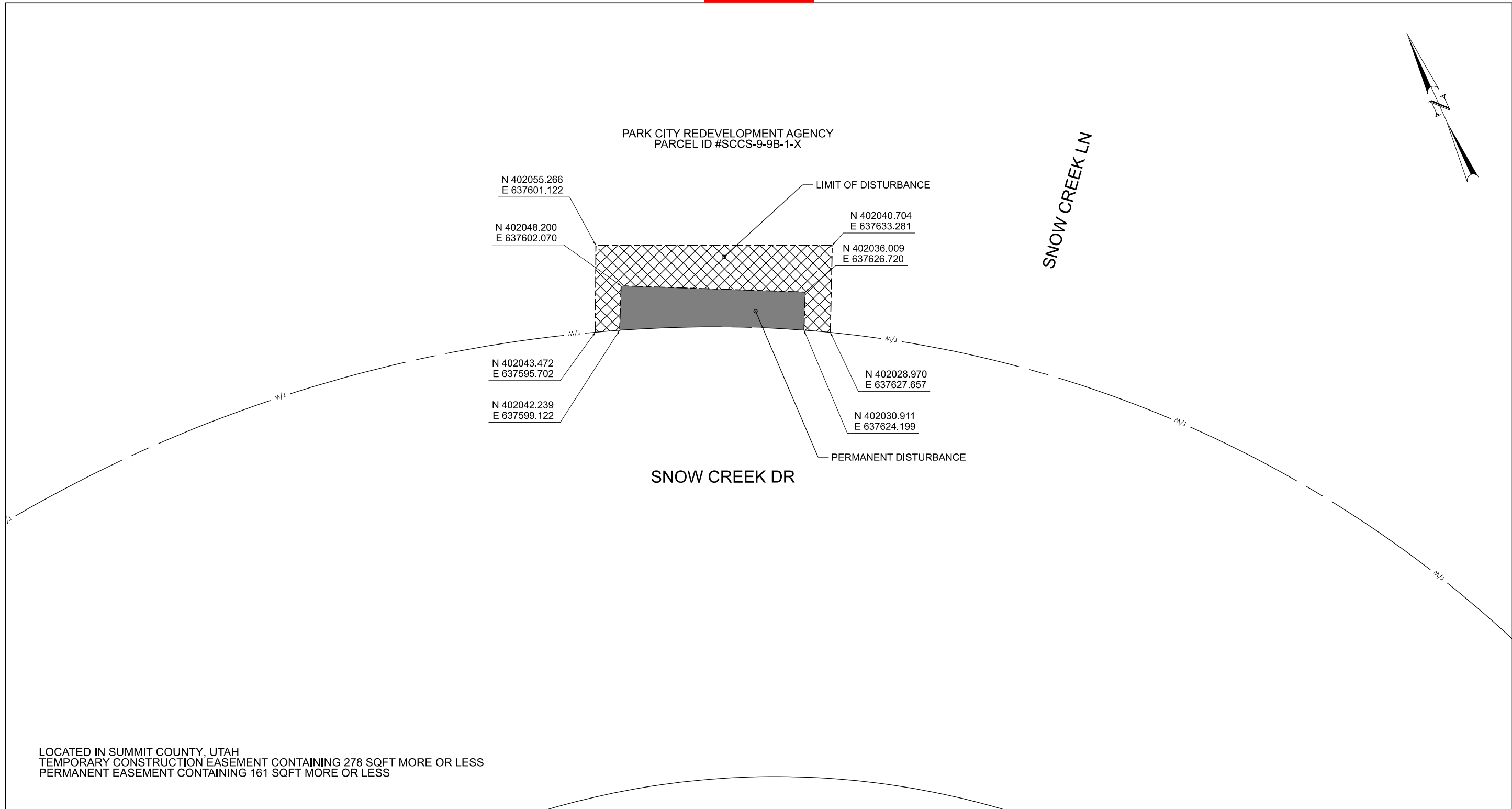

LOCATED IN SUMMIT COUNTY, UTAH
 TEMPORARY CONSTRUCTION EASEMENT CONTAINING 278 SQFT MORE OR LESS
 PERMANENT EASEMENT CONTAINING 161 SQFT MORE OR LESS

PROJECT	PARK CITY BUS STOP PROGRAM	<p>Scale (Feet)</p>	<p>RIGHT-OF-WAY PARK CITY MUNICIPAL CORPORATION KIMLEY-HORN</p>	PROPERTY OWNER: PARK CITY REDEVELOPMENT AGENCY
	PROJECT NUMBER CP0025			PROPERTY ADDRESS: 2060 PARK AVE



Redevelopment Agency Staff Report

Subject: Quit Claim of Park City Redevelopment Agency Property to UDOT
Author: Steven Dennis PE, PMP
Department: Engineering
Date: May 7, 2026

Recommendation

Authorize the Chair of the Park City Redevelopment Agency (RDA) to execute a quit claim deed, in a form approved by the City Attorney’s Office, transferring ownership of a parcel of land residing within the Marsac roundabout to the Utah Department of Transportation (UDOT).

Executive Summary

In October 2025, UDOT submitted an unsolicited request to acquire approximately 22,800 square feet (0.53 acres) of property owned by Park City Municipal Corporation (PCMC) and the Park City Redevelopment Agency (RDA) surrounding the Marsac roundabout on SR-224.

The request is not tied to a specific project, but rather to clarify ownership of land underlying a state-controlled roadway. Staff recommends conveying the requested property to UDOT to streamline maintenance operations and reduce potential liability exposure.

Analysis

Although RDA retains title to portions of the land, UDOT controls and operates the roadway. The split ownership creates administrative and legal inefficiencies:

- UDOT must obtain permits from RDA to perform maintenance activities.
- PCMC has been named in litigation related to vehicular accidents occurring on a state-controlled roadway due to underlying land ownership.

The parcels have no independent development potential and provide no practical benefit to PCMC or the RDA, as they are fully within the SR-224 roadway footprint.

Conveying the property would not change roadway operations, but would:

- Streamline maintenance and capital improvements.
- Align ownership with operational control.
- Reduce potential liability exposure for PCMC.

Parcel ID	Owner	Current Size	Requested Portion
PC-476-B-X	RDA	0.47 acres	0.31 acres

Funding

Staff recommends that the RDA convey the property to UDOT for \$10.00. UDOT will cover all third-party costs associated with preparing and executing the quit claim deed.

Exhibits
A. Requested Area

