

DAGGETT COUNTY MUNICIPAL BUILDING AUTHORITY AGENDA
Tuesday, March 31, 2026 AT 9:30 A.M.
Daggett County Courthouse (95 North 1st West; Manila, UT 84046)
Public Access Is Available Through Electronic Means At
meet.google.com/ewi-tjgt-axg

9:30 A.M. STANDING BUSINESS

- A. Welcome And Introduction Of Those Attending Electronically By Name
- B. Review of Minutes
- C. Issues Updates – Discussion Only
 - a. Water Treatment Plant Project
 - b. New Clinic Building Project
 - c. Legislation Discussion
- D. Citizen Comments - 5 minutes
- E. MBA Cash Summary Report & MBA Accounts Receivable Report
- F. MBA Open Invoice Register & Reimbursement Register
- G. MBA Disbursement Summary
- H. MBA Correspondence – Discussion Only
- I. MBA Calendar Review

POLICY AND LEGISLATION

- 1. Discussion And Consideration Of Change Order #10 IN The Amount Of \$63,595.94 For The Daggett County Health, Business And Community Center
- 2. Discussion And Consideration Of Change Order #11 IN The Amount Of \$11,318.26 For The Daggett County Health, Business And Community Center
- 3. Discussion And Consideration Of Water Treatment Plant Change Order # 5 In The Amount Of \$76,598. For Roofing
- 4. Discussion And Consideration Of Work Release #2026-1 For Daggett County/Dutch John Wastewater Improvements Project 2026

Closed Session For Discussion Of Items Permitted By §52-4-205 Of State Code**

Draft Minutes of the Meeting of the Daggett County Municipal Building Authority held on **Tuesday, March 24, 2026** in the Commission Chambers in the Daggett County Courthouse at 95 North 1st West in Manila, Utah and through electronic means. Board Members Matt Tippetts, Randy Asay and Jack Lytle attended in person. Auditor Keri Pallesen, Attorney Kent Snider, Deputy Clerk Nicole White attended in person. The meeting was called to order at 9:53 am by Board Member Tippetts.

Present In Person: Peggy White, Jordynn Hewiit, Jesse Platt Cordell McCracken

Present Online or by Phone: Aaron Averett

Approve MBA Minutes: The MBA minutes from Tuesday, March 17, 2026 were made available by the Clerk's Office for review by the Board Members. Board Member Asay motioned to approve the minutes for March 17, 2026. Board Member Lytle seconded the motion. The Board Members voted as follows on the motion.

	Yes	No	Abstained	Absent
Board Member Tippetts:	X			
Board Member Lytle:			X	
Board Member Asay:	X			

The motion carried.

Issue Updates

Water Treatment Plant: Board Member Lytle stated there is progress he just doesn't have a new detailed update at this time.

Time was given to Aaron Averett, testing is happening. Water is following through parts of the process.

New Clinic: Jesse Platt took a minute to provide a new update. Mud and tape starts Thursday. Doors delivered this morning.

Citizen Comments: No citizen comments at this time.

MBA Cash Summary and MBA Accounts Receivable Report: The MBA Cash Summary and MBA Accounts Receivable Report was provided by the Recorder/Treasurer's Office and reviewed by the Board Members. Board Member Lytle motioned to acknowledge receipt of the MBA Cash Summary Dated March 19, 2026 and MBA Accounts Receivable Report. Board Member Asay seconded the motion. The Board Members voted as follows on the motion:

	Yes	No	Abstained	Absent
Board Member Tippetts:	X			
Board Member Lytle:	X			
Board Member Asay:	X			

The motion carried.

MBA Open Invoice Register: The MBA Open Invoice Register was provided by the Auditor's Office and reviewed by the Board Members. Board Member Lytle motioned to approve the MBA Open Invoice Register dated March 19, 2026 in the amount of \$11,504.19. Board Member Asay seconded the motion. The Board Members voted as follows on the motion:

Yes	No	Abstained	Absent
-----	----	-----------	--------

Board Member Tippetts: X
Board Member Lytle: X
Board Member Asay: X

The motion carried.

MBA Disbursement Summary: The MBA Disbursement Summary was provided by the Auditor’s Office and reviewed by the Board Members. Board Member Lytle motioned to approve the MBA Disbursement Summary dated March 15, 2026 to March 19, 2026 in the amount of \$1,289.38. Board Member Asay seconded the motion. The Board Members voted as follows on the motion:

	Yes	No	Abstained	Absent
Board Member Tippetts:	X			
Board Member Lytle:	X			
Board Member Asay:	X			

The motion carried.

Correspondence / Calendar: There was nothing new to report at this time.

Policy and Legislation

With nothing further to consider, Board Member Tippetts adjourned the meeting by acclamation at 10:00 am.

**County of Daggett
Cash Summary
All Bank Accounts as of 03/27/2026**

Bank Account	Account No.	Account Name	Amount
Zions Checking	10.1122	Zions Checking - General	(\$118,389.09)
Zions Checking	11.1122	Cash - checking - Zions Fd 11	\$1,483,305.18
Zions Checking	12.1122	Cash - checking - Zions Fd 12	\$181,721.35
Zions Checking	13.1122	Cash - checking - Zions Fd 13	\$381,840.03
Zions Checking	15.1122	Zions Checking - General	\$6,302.46
Zions Checking	17.1122	Cash - Checking - Zions Fd 17	\$12,521.71
Zions Checking	18.1122	Cash - Checking - Zions Fd 18	\$39,844.61
Zions Checking	19.1122	Zions Checking - General	\$313,512.21
Zions Checking	20.1122	Cash-Checks-Zions fd 20	\$3,667.26
Zions Checking	22.1122	Cash - checking Zions Fd 22	\$466,614.08
Zions Checking	23.1122	Cash - checking - Zions Fd 23	\$559,889.19
Zions Checking	24.1122	Cash - checking - Zions Fd 24	\$4,514.54
Zions Checking	25.1122	Cash - checking - Zions Fd 25	\$645,584.39
Zions Checking	27.1122	Cash - checking - Zions Fd 27	\$3,745.51
Zions Checking	28.1122	Cash - checking - Zions Fd 28	\$494,842.08
Zions Checking	30.1122	Cash - Checking - Zions Fd 30	\$10,644.43
Zions Checking	32.1122	Cash - checking Zions FD 32	\$13,889.78
Zions Checking	33.1122	Cash - checking - Zions Fd	\$64,452.01
Zions Checking	34.1122	Cash-Checking-Zions Fd 34	\$1,024,834.99
Zions Checking	35.1122	Zions Checking	(\$23,936.21)
Zions Checking	37.1122	Zions Checking - Combined	\$24,787.35
Zions Checking	40.1122	Cash - checking - Zions Fd 40	\$257,714.36
Zions Checking	45.1122	Cash - Checking - Zions Fd 45	(\$1,500,923.59)
Zions Checking	47.1122	Zions Checking - General	\$19,791.16
Zions Checking	49.1122	Checking - Zions Fd 49	\$58,472.72
Zions Checking	50.1122	Cash-Checking-Zions Fd 50	\$53,511.05
Zions Checking	72.1122	Cash - checking - Zions Fd 72	\$12,529.63
Zions Checking	74.1122	Cash - checking - Zions Fd 74	\$21,318.40
Zions Checking	75.1122	Cash - checking - Zions Fd 75	\$36,275.45
Zions Checking	76.1122	Cash - checking - Zions Fd 76	\$29,807.95
Zions Checking	77.1122	Cash - checking - Zions Fd 77	(\$196.53)
Zions Checking	78.1122	Cash - checking - Zions Fd 78	\$10,643.39
Zions Checking	80.1122	Cash - checking - Zions Fd 80	\$4,139.82
Zions Checking	81.1122	Zions Checking - General	\$3.20
			\$4,597,274.87
PTIF 2259 General Accounts	10.1151	PTIF 2259 General	\$9,133.50
PTIF 2259 General Accounts	11.1151	PTIF 2259 General	\$255,562.97
PTIF 2259 General Accounts	12.1151	PTIF 2259 General	\$47,991.00
PTIF 2259 General Accounts	13.1151	PTIF 2259	\$103,949.81
PTIF 2259 General Accounts	50.1151	PTIF 2259 General	\$170.00
			\$416,807.28
PTIF 2552 General Fund	10.1161	PTIF 2552 General Fund	\$6,008.08
PTIF 2552 General Fund	28.1161	PTIF 2552 Home Sales	\$21,066.06
			\$27,074.14
PTIF 2772 Farm & Ranch Protection	10.1162	PTIF 2772 General Fund	\$20,788.51
PTIF 2772 Farm & Ranch Protection	47.1162	PTIF 2772 General Fund	\$18.21
			\$20,806.72
PTIF 2834 General Fund	10.1153	PTIF 2834 General Fund	\$194.26
PTIF 3465 General Fund	10.1163	PTIF 3465 General Fund	\$23,779.03
PTIF 3932 General Fund	10.1154	PTIF 3932 General Fund	\$12,499.98
PTIF 5583 Daggett County RDA Fund	25.1151	PTIF 5583 Daggett County RDA	\$1,406,054.77
PTIF 5610 Daggett County Redevelopment #1	25.1158	PTIF 5610 Daggett County RDA	\$869,530.76
PTIF 8676 Water Revenue Bond	28.1168	PTIF 8676 Water Revenue Bond	\$124,215.51
PTIF 8699 WT Bond Reserve Account	28.1169	PTIF 8699 WT Bond Reserve Account	\$25,377.77
PTIF 8700 WT 2015 Replacement Account	28.1170	PTIF 8700 WT 2015 Replacement Account	\$122,793.27
Zions Tax Collection 026134668	81.1130	Zions Checking - Tax Collection	\$147,025.10
PTIF 3200 Motor Vehicle	81.1131	PTIF 3200 Motor Vehicle	\$10,658.06
UNDEPOSITED PAYMENTS	10.1175	Cash clearing	\$942.95
UNDEPOSITED PAYMENTS	12.1175	Cash clearing	\$0.02
UNDEPOSITED PAYMENTS	25.1175	Cash Clearing	\$856.33
UNDEPOSITED PAYMENTS	28.1175	Cash clearing	\$5,092.16

**County of Daggett
Cash Summary
All Bank Accounts as of 03/27/2026**

<u>Bank Account</u>	<u>Account No.</u>	<u>Account Name</u>	<u>Amount</u>
UNDEPOSITED PAYMENTS	32.1175	Cash clearing	\$3,199.00
UNDEPOSITED PAYMENTS	33.1175	Cash clearing	(\$1,698.60)
UNDEPOSITED PAYMENTS	35.1175	Cash Clearing	\$3,584.07
UNDEPOSITED PAYMENTS	40.1175	Cash Clearing	\$0.01
UNDEPOSITED PAYMENTS	72.1175	Cash clearing	\$583.87
UNDEPOSITED PAYMENTS	74.1175	Cash clearing	\$0.03
UNDEPOSITED PAYMENTS	76.1175	Cash clearing	\$766.00
UNDEPOSITED PAYMENTS	80.1175	Cash clearing	\$109.14
UNDEPOSITED PAYMENTS	81.1175	Cash clearing	\$9,674.33
			\$23,109.31
General Ledger Cash Total:			\$7,827,200.83

**County of Daggett
Cash Summary
All Bank Accounts as of 03/27/2026**

Description	Amount
Zions Checking	\$4,597,274.87
PTIF 2259 General Accounts	\$416,807.28
PTIF 2552 General Fund	\$27,074.14
PTIF 2772 Farm & Ranch Protection	\$20,806.72
PTIF 2834 General Fund	\$194.26
PTIF 3465 General Fund	\$23,779.03
PTIF 3932 General Fund	\$12,499.98
PTIF 5583 Daggett County RDA Fund	\$1,406,054.77
PTIF 5610 Daggett County Redevelopment #1	\$869,530.76
PTIF 8676 Water Revenue Bond	\$124,215.51
PTIF 8699 WT Bond Reserve Account	\$25,377.77
PTIF 8700 WT 2015 Replacement Account	\$122,793.27
Zions Tax Collection 026134668	\$147,025.10
PTIF 3200 Motor Vehicle	\$10,658.06
UNDEPOSITED PAYMENTS	\$23,109.31
General Ledger Cash Total:	\$7,827,200.83

Accounts Receivable Report for Commission

Who:	Fund:	What:	How Much:	Received:	Notes:
UDOT	50	Advertising Invoice for SR-43 Trail	\$1,320.00		Payment being sent 02/26/2026
State of Utah	45	Water Tank	\$15,351.73		Submitted 02/20/2026
State of Utah	30	SHSP Grant	\$6,119.80		Submitted 02/24/2026
CIB	45	Manila Health Clinic	\$1,340,076.03		Working on Submittal
CIB	45	Dutch John Tank & Treatment Plant	\$46,740.54		Submitted 03/27/2026

Municipal Building Authority of Daggett County

Open Invoice Register - 3/25/2026

Invoice No.	Vendor	General		Amount	Account No.	Account Name.	Description
		Ledger Date	Due Date				
49210/1	Benedict's Market	3/6/26	3/6/26	\$ 22.98			
				\$ 22.98	454100.740	MBA Capital outlay	Water Treatment Plant crimp ring and tees
243739	Mountain West Propane Inc.	3/12/26	3/12/26	\$ 4,469.68			
				\$ 4,469.68	454100.740	MBA Capital outlay	Propane Set Up - Serial #2022368 Water Treatment #2 Generator Acct#110798
S107695153.001	Mountainland Supply	3/13/26	3/13/26	\$ 36.98			
				\$ 36.98	454100.740	MBA Capital outlay	Water Treatment Plant Poly Pex 90 elbow, PVC threaded plug, PVC SS Coupling
ARIV1008763B	Sunrise Engineering, Inc.	12/8/25	12/8/25	\$ 360.00			
				\$ 360.00	454100.740	MBA Capital outlay	Water Treatment Plant Professional Services through November 29, 2025 - remaining balance on invoice
565727 01	Vernal Winnelson Co	3/16/26	3/16/26	\$ 752.93			
				\$ 752.93	454100.740	MBA Capital outlay	Water Treatment Plant Valves, wire, adaptaters, bushings, switch, other misc items
566269 01	Vernal Winnelson Co	3/20/26	3/20/26	\$ 32.40			
				\$ 32.40	454100.740	MBA Capital outlay	Water Treatment Plant brass nipples, bushings, and tees
	Vendor Total:			\$ 785.33			
	Total			\$ 5,674.97			
				\$ 5,674.97	454100.740	MBA Capital outlay	
				\$ 5,674.97		Total	

GL Account Summary

\$ 5,674.97 454100.740 MBA Capital outlay
\$ 5,674.97 Total

Municipal Building Authority of Daggett County

Open Invoice Register - 3/25/2026

Invoice No.	Vendor	General							
		Ledger Date	Due Date	Amount	Account No.	Account Name.			Description

Municipal Building Authority of Daggett County
Disbursement Summary
Zions Checking - 03/19/2026 to 03/25/2026

Payee Name	Reference No.	Payment Date	Payment Amount	Void Date	Void Amount	Source
Gray's Market LLC	101041	3/23/2026	\$ 28.35			Purchasing
State of Utah Division of Finance	101050	3/23/2026	\$ 11,475.84			Purchasing
			\$ 11,504.19		\$ -	



AIA[®]

Document G701[®] – 2017

Change Order

PROJECT: *(Name and address)*
Daggett County Health, Business and
Community Center
105 North 100 West
Manilla, Utah 84046

CONTRACT INFORMATION:
Contract For: General Construction

Date: 06-25-2025

CHANGE ORDER INFORMATION:
Change Order Number: 010

Date: 03/24/2026

OWNER: *(Name and address)*
Daggett County Municipal Building
Authority
105 North 100 West
Manilla, Utah 84046

ARCHITECT: *(Name and address)*
Campbell Architecture

46 North 200 East
St. George, Utah 84770

CONTRACTOR: *(Name and address)*
Hadfield Construction LLC

2650 Washington Blvd, Se 205
Ogden, Utah 84401

THE CONTRACT IS CHANGED AS FOLLOWS:

(Insert a detailed description of the change and, if applicable, attach or reference specific exhibits. Also include agreed upon adjustments attributable to executed Construction Change Directives.)

- 1. Refer to attached PCO's 13, 15, 17, 18, 19, 20R1, 21, 22

The original Contract Sum was	\$ 5,320,000.00
The net change by previously authorized Change Orders	\$ 773,694.30
The Contract Sum prior to this Change Order was	\$ 6,093,694.30
The Contract Sum will be increased by this Change Order in the amount of	\$ 63,595.94
The new Contract Sum including this Change Order will be	\$ 6,157,290.24

The Contract Time will be unchanged by two (2) days.
The new date of Substantial Completion will be September 2, 2026

NOTE: This Change Order does not include adjustments to the Contract Sum or Guaranteed Maximum Price, or the Contract Time, that have been authorized by Construction Change Directive until the cost and time have been agreed upon by both the Owner and Contractor, in which case a Change Order is executed to supersede the Construction Change Directive.

NOT VALID UNTIL SIGNED BY THE ARCHITECT, CONTRACTOR AND OWNER.

Campbell Architecture

Hadfield Construction LLC

Daggett County Municipal Building
Authority

ARCHITECT *(Firm name)*

CONTRACTOR *(Firm name)*

OWNER *(Firm name)*

Krystal Watts
SIGNATURE

Jade Hadfield
SIGNATURE

SIGNATURE

Krystal Watts, Architect
PRINTED NAME AND TITLE

Jade Hadfield, Managing Member
PRINTED NAME AND TITLE

Jesse Platt, Project Manager
PRINTED NAME AND TITLE

Mar 24 2026
DATE

Mar 24 2026
DATE

DATE



PCO 13 Date 2.05.2026
 Project Name Daggett County HBC Center Project Number 2307-006
 Agency Daggett County Municipal Building Authority Contract Number _____
 A/E Campbell Architecture

PCO Or CCD Number	Description of work Must include reasoning as to why the change occurred	Amount	Days
13	Lead lined drywall for X-ray room	\$ 13,333.10	2
Total This Change Order		\$ 13,333.10	2

		Date	Days
Original Contract	\$ 5,320,000.00		
Total Previous Change Orders			
Total This Change order	\$ 13,333.10		2
Adjusted Contract	\$		

- This change order is issued under the following conditions:
1. This work is to be performed in strict accordance with the terms of the Contract Documents, including prior issued Change Orders and Construction Change Directives, except as modified by this Change Order.
 2. The rights of Hadfield Construction are not prejudiced.
 3. The Contractor agrees that the terms, contract sum, scope of the Work and time specified in this Change Order shall constitute the full accord and satisfaction, and complete adjustment to the Contract and includes all direct and indirect costs and effects related to, incidental to, a consequence of and/or reasonably implied from such change in the contract terms, sum, scope of the Work and time.
 4. Documents submitted with this Change Order are hereby incorporated as part of the Contract Documents for this Project.
 5. This change order is not effective until executed by the Agency below.
 6. Signature of the Contractor below indicates agreement herewith.

THE TERMS AND CONDITIONS OF THIS CHANGE ORDER ARE HEREBY ACCEPTED:

Contractor: Date: 2.5.2026
 Architect/Engineer _____
 Agency/Institution: _____



Dagget County Health
Attn: Radiology Manager
105 North 1st West
Manila, UT 84046

c/o

Bart Jensen, PE, PLS
Jones & DeMille Engineering, Inc
38 West 100 North
Vernal, UT 84078

Jason Kelly
Radiology Manager
Uintah Basin Health Care
Roosevelt, UT 84066

12/4/2025

Subject: Shielding Recommendations for Dagget County Clinic X-ray Room

I have reviewed the floor plans for the Dagget County Clinic X-ray room to be located at 105 North 1st West, Manila, UT. Based on the calculations and assumptions detailed below, I recommend 2# (0.7937 mm, 1/32-in) lead to be installed in south wall along the indicated corridor (Figure 1). Additionally, I recommend at least 1# (0.3969 mm, 1/64-in) Pb in the other remaining walls, room door, and control booth.

These recommendations are based on a workload of 125 exposures per week in in the X-ray room. The shielding recommendations are given such that exposure will be maintained to levels well below the non-occupational dose limit of 100 mrem (1 mSv) per year for all adjacent areas outside the rooms and well below 10% of the occupational dose limit of 5,000 mrem (50 mSv) in the control room.

I have attached tables of the calculations as well as floor plans with the shielding recommendations indicated. Please note that if the assumptions or other parameters used in calculations change, the shielding recommendations will need to be reassessed.

Please let me know if you have any questions.

Sincerely,

Peter Jenkins, PhD, CHP, DABR
Diagnostic Medical Physicist

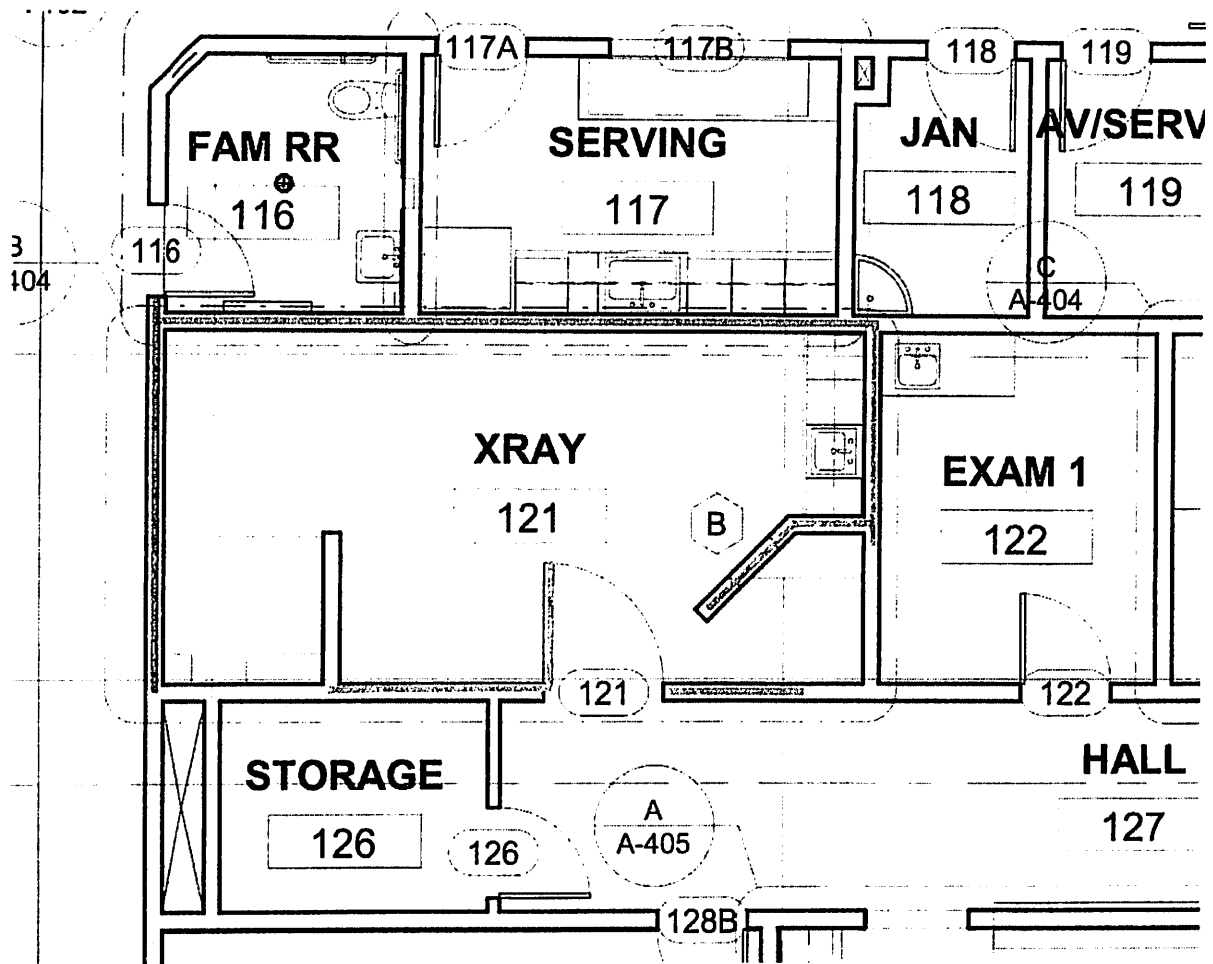

Figure 1. Dagget County Clinic X-ray room floor plan. The red lines indicate the required 2# Pb shielding to be installed. The green lines indicate the walls where 1# Pb is recommended.

Manila - X-Ray Room

Machine:	General X-ray
Workload:	125 exams/week
est. unshielded primary air kerma (K _{PRD} (0)):	5.20 mGy/exam ^{1,2}
est. unshielded primary air kerma (K _{PRD} (0)), chest bucky:	2.30 mGy/exam ^{1,2}
est. unshielded secondary air kerma (K _{SEC} (0)):	0.03 mGy/exam ^{1,3}

	Distance (m)		Secondary Use Factor (U)	Primary Use Factor (U)	Occupancy (T)	Design Goal (P) (mSv/wk)	K _{SEC} (0)	K _{PRD} (0)	required transmission B(x)		A _{PRD} (mm Pb)	x (mm Pb) ^{1,4}		existing equivalent (mm Pb)	effective need (mm Pb)	Minimum lead (lb/ft ²)	Recommend ed lead (lb/ft ²)
	SEC	PRI							SEC	PRI		SEC	PRI				
1 Fam RR (116)	5.50	—	1.00	—	0.20	0.02	0.136	—	7.33E-01	—	0.00	0.017	0.000	0.10	-0.083	none	none
2 Servng (117)	3.90	—	1.00	0.09	1.00	0.02	0.271	—	7.37E-02	—	0.00	0.271	0.000	0.10	0.171	1#	1#
3 Jan (118)	6.10	—	1.00	—	0.03	0.02	0.111	—	7.22E+00	—	0.00	-0.060	0.000	0.10	-0.160	none	none
4 South Corridor	4.27	2.13	1.00	1.00	0.20	0.02	0.227	63.156	4.41E-01	1.58E-03	0.85	0.052	1.453	0.10	0.555	2#	2#
5 Storage (126)	4.60	—	1.00	—	0.03	0.02	0.195	—	4.10E+00	—	0.00	0.050	0.000	0.10	-0.150	none	none
6 Hall (127)	3.70	—	1.00	0.02	0.20	0.02	0.301	—	3.32E-01	—	0.00	0.076	0.000	0.10	-0.024	none	1#
7 Room Door (121)	2.40	—	1.00	—	0.13	0.02	0.716	—	2.23E-01	—	0.00	0.115	0.000	0.10	0.015	1#	1#
8 Exam 1 (122)	3.90	—	1.00	—	1.00	0.02	0.271	—	7.37E-02	—	0.00	0.271	0.000	0.10	0.171	1#	1#
9 Ceiling	3.00	—	1.00	—	0.03	0.02	0.458	—	1.75E+00	—	0.00	-0.024	0.000	0.10	-0.124	none	none
10 Floor	3.90	4.30	1.00	0.89	0.20	0.02	0.271	15.549	3.69E-01	7.23E-03	0.00	0.067	0.914	1.05	-0.069	none	none

Notes

- 2 layers of 5/8 in (31.75 mm) gypsum equivalent to B of 0.3 - 0.1 mm Pb
- 1 # lead is equivalent to 0.4 mm
- 2 # lead is equivalent to 0.8 mm
- Floor construction - 3" deep, 20 gauge steel deck with 3 1/4" concrete, no shielding necessary
- 0.05 mmPb equiv in Bucky and Detector - 0.2 mm equiv in floor construction
- The 1# Pb-equiv Room Door, with a needed Transmission of 0.015, may be replaced with a Solid-Wood door

	Total
1 Fam RR (116)	none
2 Servng (117)	1#
3 Jan (118)	none
4 South Corridor	2#
5 Storage (126)	none
6 Hall (127)	1#
7 Room Door (121)	1#
8 Exam 1 (122)	1#
9 Ceiling	none
10 Floor	none

Table 1. Summary of calculation results for Manila X-Ray Room #1

References

- National Council of Radiation Protection and Measurements (NCRP) Report 147 2005 Structural Shielding Design for Medical X-Ray Imaging Facilities TABLE 4-5 - Unshielded primary air kerma per patient
- National Council of Radiation Protection and Measurements (NCRP) Report 147 2005 Structural Shielding Design for Medical X-Ray Imaging Facilities TABLE 4-7 - Unshielded secondary air kerma per patient
- Fitting parameters from NCRP 147 Table C-1 Rad Room (all barriers)
- Fitting parameters from NCRP 147 Table B-1 Rad Room (chest bucky)
- Fitting parameters from NCRP 147 Table B-1 Rad Room (all barriers)

ESTIMATE

Hadfield Construction LLC
2650 Washington Blvd, Ste 205
Ogden, UT 84401

jade@hadfieldco.com
+1 (801) 300-0816
www.hadfieldco.com



Daggett County:HBC Center
Bill to
Daggett County
105 N 1st W
Manila, UT 84046

Ship to
Daggett County
105 N 1st W
Manila, Utah 84046

Estimate details

Estimate no.: 1703
Estimate date: 02/05/2026

is this not overhead

#	Product or service	Description	Qty	Rate	Amount
1.		Daggett County PCO 13			
2.	02 Site Work	Hadfield Construction	16	\$95.00	\$1,520.00
3.	02 Site Work	HD Build	1	\$10,074.00	\$10,074.00
4.	02 Site Work	Hadfield Construction P&O 15%	1	\$1,739.10	\$1,739.10
				Total	\$13,333.10

Accepted date

Accepted by



HD Build

Phone: 801-360-3264

Hadfield Construction LLC
Job Address:
105 North 1st West
Manila, UT 84046

Print Date: 2-4-2026

Daggett County HBC Center - CO #2

Change Order ID: 0002

Here is the CO for the lead lined drywall. Added labor for the install process and the added weight and difficulty of the sheets. Taping should end up being the same.
Call Layne with questions: 801-380-4346

Items	Description	Price
CO #2, Lead lined drywall for x-ray room	Materials: \$7,560 4x10 lead up 10' Lead Lined Drywall will all accessories 18 sheets with waste 1# and 2# are actually the same cost, so we are figuring all 2# Labor: \$1,200 Rate \$75/hr Added labor on the hanging and install this is just for the hours above what normal gyp would be hanging. Installing the corner pieces, the joint pieces, and the discs that go over the screws 16 hours P&O 15%: \$1,314	\$10,074.00

Total price: \$10,074.00

Please approve this Change Order if you would like to confirm the adjustment to your original Scope of Work. By approving, you acknowledge the adjustment to the construction schedule and will be invoiced upon approval or in a subsequent draw.

I confirm that my action here represents my electronic signature and is binding.

Signature: _____

Date: _____

Print Name: _____



PCO	15	Date	2.09.2026
Project Name	Daggett County HBC Center	Project Number	2307-006
Agency	Daggett County Municipal Building Authority	Contract Number	
		A/E	Campbell Architecture

PCO Or CCD Number	Description of work Must include reasoning as to why the change occurred	Amount	Days
15	Per RFI 40 new chase for line sets	\$ 1,289.44	0
Total This Change Order		\$ 1,289.44	0

		Date	Days
Original Contract	\$ 5,320,000.00		
Total Previous Change Orders			
Total This Change order	\$ 1,289.44		0
Adjusted Contract	\$		

- This change order is issued under the following conditions:
1. This work is to be performed in strict accordance with the terms of the Contract Documents, including prior issued Change Orders and Construction Change Directives, except as modified by this Change Order.
 2. The rights of Hadfield Construction are not prejudiced.
 3. The Contractor agrees that the terms, contract sum, scope of the Work and time specified in this Change Order shall constitute the full accord and satisfaction, and complete adjustment to the Contract and includes all direct and indirect costs and effects related to, incidental to, a consequence of and/or reasonably implied from such change in the contract terms, sum, scope of the Work and time.
 4. Documents submitted with this Change Order are hereby incorporated as part of the Contract Documents for this Project.
 5. This change order is not effective until executed by the Agency below.
 6. Signature of the Contractor below indicates agreement herewith.

THE TERMS AND CONDITIONS OF THIS CHANGE ORDER ARE HEREBY ACCEPTED:

Contractor: Date: 2.9.2026

Architect/Engineer _____

Agency/Institution: _____

ESTIMATE

Hadfield Construction LLC
2650 Washington Blvd, Ste 205
Ogden, UT 84401

jade@hadfieldco.com
+1 (801) 300-0816
www.hadfieldco.com



Daggett County:HBC Center

Bill to
Daggett County
105 N 1st W
Manila, UT 84046

Ship to
Daggett County
105 N 1st W
Manila, Utah 84046

Estimate details

Estimate no.: 1720
Estimate date: 02/23/2026

#	Product or service	Description	Qty	Rate	Amount
1.		Daggett County PCO 18			
2.	02 Site Work	Beacon CDL	1	\$7,030.54	\$7,030.54
3.	02 Site Work	TEK Construction	1	\$1,572.57	\$1,572.57
4.	02 Site Work	HD Build	1	\$8,050.00	\$8,050.00
5.	02 Site Work	Hadfield Construction P&O 15%	1	\$2,497.97	\$2,497.97
				Total	\$19,151.08

Accepted date

Accepted by



PCO 18 Date 2.23.2026
 Project Name Daggett County HBC Center Project Number 2307-006
 Agency Daggett County Municipal Building Authority Contract Number _____
 A/E Campbell Architecture

PCO Or CCD Number	Description of work Must include reasoning as to why the change occurred	Amount	Days
18	Add storage closets underneath stairs	\$ 19,151.08	0
Total This Change Order		\$ 19,151.08	0

		Date	Days
Original Contract	\$ 5,320,000.00		
Total Previous Change Orders			
Total This Change order	\$ 19,151.08		0
Adjusted Contract	\$		

This change order is issued under the following conditions:
 1. This work is to be performed in strict accordance with the terms of the Contract Documents, including prior issued Change Orders and Construction Change Directives, except as modified by this Change Order.
 2. The rights of Hadfield Construction are not prejudiced.
 3. The Contractor agrees that the terms, contract sum, scope of the Work and time specified in this Change Order shall constitute the full accord and satisfaction, and complete adjustment to the Contract and includes all direct and indirect costs and effects related to, incidental to, a consequence of and/or reasonably implied from such change in the contract terms, sum, scope of the Work and time.
 4. Documents submitted with this Change Order are hereby incorporated as part of the Contract Documents for this Project.
 5. This change order is not effective until executed by the Agency below.
 6. Signature of the Contractor below indicates agreement herewith.

THE TERMS AND CONDITIONS OF THIS CHANGE ORDER ARE HEREBY ACCEPTED:

Contractor: [Signature] Date: 2.23.2026
 Architect/Engineer _____
 Agency/Institution: _____

RFI #47 Additional

Self Performed Labor						
PS	Project Superintendant	1	Hrs	\$	106.00	\$ 106.00
PF	Project Foreman	1	Hrs	\$	86.00	\$ 86.00
C1	Carpenter	1	Hrs	\$	75.00	\$ 75.00
TEK Owned Equipment						
Delivery	Salt Lake to Manila	1	Ls	\$	25.00	\$ 25.00
Materials						
THAI4422 Truss Hanger	Wheelright Lumber	1	Ea	\$	33.46	\$ 33.46
Tecco Nails	Wheelright Lumber	1	Box	\$	5.99	\$ 5.99
Cost Total						\$ 331.45
Profit/Overhead (15%)						\$ 49.72
Price Total						\$ 381.17



WHEELWRIGHT
L U M B E R

Wheelwright Lumber Co.
3127 South Midland Drive
Ogden UT 84401
801-627-0850
Fax: 801-627-9933



ORDER
2602-C93200 PAGE 1 OF 1

SOLD TO

TEK CONSTRUCTION LLC#
845 S MAIN
SUITE A4
BOUNTIFUL UT 84040

JOB ADDRESS

DAGGETT COMMUNITY CENTER
105 N 1ST WEST
MANILLA UT
307-677-6790

ACCT NO.	JOB
242084	14
ENTRY DATE	2/16/2026 10:27:15 AM
CUST PICKUP	
BRANCH	1000
CUSTOMER PO#	1074
STATION	WB
CASHIER	JASON
SALESPERSON	MCKAY
ORDER ENTRY	JASON
MODIFIED BY	JASON

Thank you for your business.
Special order items are non refundable. FED ID 87-0193460

Item	Description	D	Ordered	Sold	Remain	UM	Price	Per	Amount
2616F	2X8-16 #2&tr White Fir		15		15	EA	11.0300	EA	165.45
2420F	2X4-20 #2&tr White Fir		11		11	EA	9.1000	EA	100.10
SDS25412MB	1/4"X4-1/2" SDS SCREWS 100/PACK		2		2	BX	74.2000	BX	148.40
LUS292	LUS28-2 LT DBL 2X8 JOIST HANGER		4		4	EA	3.4900	EA	13.96
3723226	1LB BOX 1-1/2" GALV TECO NAILS JOIST NAILS		1		1	BX	5.9900	BX	5.99
07334262	3/8" X 6' THREADED ROD		2		2	EA	9.9900	EA	19.98
38WE	3/8 USS FLAT WASHER PER EACH		18		18	EA	0.2700	EA	4.86
38HNE	3/8"-16 HEX NUT ZINC		18		18	EA	0.2600	EA	4.68
7101207	48-27-0501 BIT FLAT BORE 1/2X8		1		1	CD	7.9900	CD	7.99
SQC93200-000	THAI422 ADJUSTABLE I-JOIST TRUSS HANGER		2		2	EA	16.7300	EA	33.46

ESTIMATE

Hadfield Construction LLC
2650 Washington Blvd. Ste 205
Ogden, UT 84401

jade@hadfieldco.com
+1 (801) 300-0816
www.hadfieldco.com



Daggett County:HBC Center
Bill to
Daggett County
105 N 1st W
Manila, UT 84046

Ship to
Daggett County
105 N 1st W
Manila, Utah 84046

Estimate details

Estimate no.: 1716
Estimate date: 02/19/2026

#	Product or service	Description	Qty	Rate	Amount
1.		Daggett County, PCO 17			
2.	02 Site Work	TEK Construction	1	\$381.17	\$381.17
3.	02 Site Work	Hadfield Construction P&O 15%	1	\$57.18	\$57.18
				Total	\$438.35

Accepted date

Accepted by

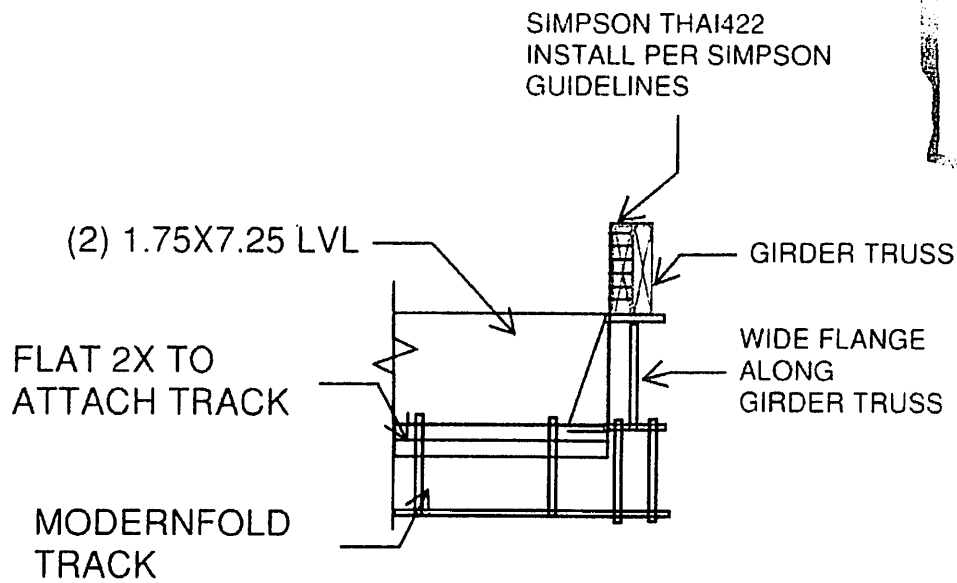
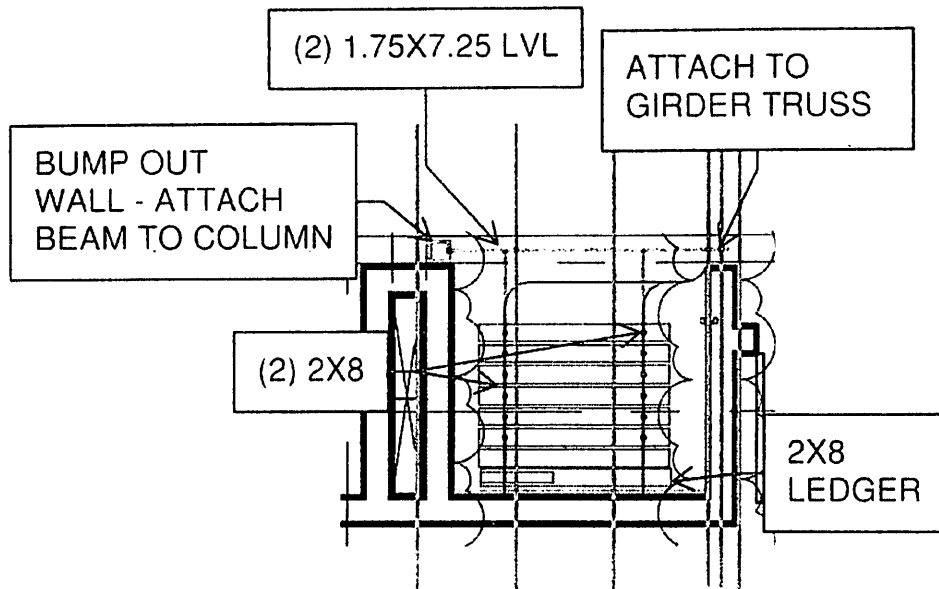

Detail to attach wood LVL to girder truss.



Seth Robertson, P.E.

Project Engineer

Jones & DeMille Engineering, Inc.

p: (435) 896-8266 | m: (435) 893-5850

Shaping the Quality of Life

From: Seth Robertson <seth.r@jonesanddemille.com>

Sent: Friday, January 30, 2026 11:44 AM

To: hady@hadfieldco.com <hady@hadfieldco.com>

Subject: Re: Additional curtain wall details:

Just spoke with Krystal, she's okay if we frame out the wall to match the location we need the column on that one side. (shown on the screenshot as orange)

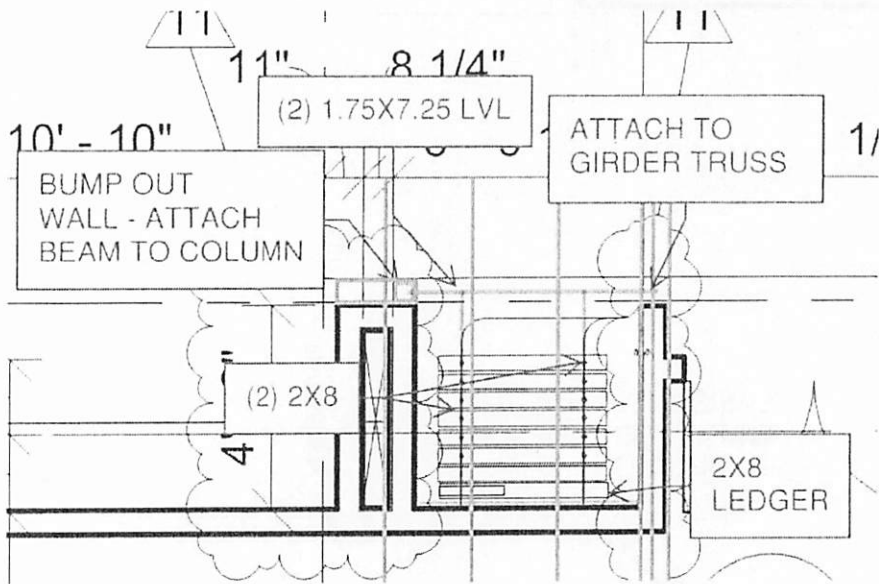

From: Seth Robertson <seth.r@jonesanddemille.com>

Sent: Friday, January 30, 2026 11:29 AM

To: hady@hadfieldco.com <hady@hadfieldco.com>

Subject: Additional curtain wall details:

Hady,

Here is the solution I've come up with for the modern fold curtain wall in the community room.

Coming off of the main steel beam track will be an LVL beam attached to the girder truss as shown in the detail below. That beam will connect to a wood column and the wall will have to bump out 10" at that location. The rest of the framing can be done with (2) 2x8 and the ledger as previously discussed.



PCO 17 Date 2.19.2026
 Project Name Daggett County HBC Center Project Number 2307-006
 Agency Daggett County Municipal Building Authority Contract Number A/E
Campbell Architecture

PCO Or CCD Number	Description of work Must include reasoning as to why the change occurred	Amount	Days
17	Change the area were the curtain wall retracks	\$ 438.35	0
Total This Change Order		\$ 438.35	0

		Date	Days
Original Contract	\$ 5,320,000.00		
Total Previous Change Orders			
Total This Change order	\$ 438.35		0
Adjusted Contract	\$		

- This change order is issued under the following conditions:
1. This work is to be performed in strict accordance with the terms of the Contract Documents, including prior issued Change Orders and Construction Change Directives, except as modified by this Change Order.
 2. The rights of Hadfield Construction are not prejudiced.
 3. The Contractor agrees that the terms, contract sum, scope of the Work and time specified in this Change Order shall constitute the full accord and satisfaction, and complete adjustment to the Contract and includes all direct and indirect costs and effects related to, incidental to, a consequence of and/or reasonably implied from such change in the contract terms, sum, scope of the Work and time.
 4. Documents submitted with this Change Order are hereby incorporated as part of the Contract Documents for this Project.
 5. This change order is not effective until executed by the Agency below.
 6. Signature of the Contractor below indicates agreement herewith.

THE TERMS AND CONDITIONS OF THIS CHANGE ORDER ARE HEREBY ACCEPTED:

Contractor: Date: 2.19.2026
 Architect/Engineer _____
 Agency/Institution: _____



HD Build

Phone: 801-360-3264

Hadfield Construction LLC

Job Address:

105 North 1st West

Manila, UT 84046

Print Date: 2-4-2026

Daggett County HBC Center - CO #1

Change Order ID. **0001**

We already have the one layer of 5/8" gyp hang and finish, so no add on that. There will be the shaft wall and then a layer of 5/8" gyp added.

This is priced based on the conversation with the architect and the RFI that I sent.

Call Layne with questions. 801-380-4346

Items	Description	Price
CO #1, #40 Line Sets	Material: \$425 Shaft liner 1"/CH studs and J track layer of 5/8" gyp/tile backer Labor: \$300 Rate \$75/hr Man hours framing and installing shaft wall 4 hours Travel: \$250 1 extra night hotel and perdiem P&O 15%: \$146.25	\$1,121.25

Total price: \$1,121.25

Please approve this Change Order if you would like to confirm the adjustment to your original Scope of Work. By approving, you acknowledge the adjustment to the construction schedule and will be invoiced upon approval or in a subsequent draw.

Approval Deadline: Feb 10, 2026

ESTIMATE

Hadfield Construction LLC
2650 Washington Blvd. Ste 205
Ogden, UT 84401

jade@hadfieldco.com
+1 (801) 300-0816
www.hadfieldco.com



Daggett County:HBC Center

Bill to

Daggett County

105 N 1st W

Manila, UT 84046

Ship to

Daggett County

105 N 1st W

Manila, Utah 84046

Estimate details

Estimate no.: 1707

Estimate date: 02/09/2026

#	Product or service	Description	Qty	Rate	Amount
1.		Daggett County PCO 15			
2.	02 Site Work	HD Build	1	\$1,121.25	\$1,121.25
3.	02 Site Work	Hadfield Construction P&O 15%	1	\$168.19	\$168.19
				Total	\$1,289.44

Accepted date

Accepted by



Jones & DeMille Engineering
 520 West Hwy 40
 Roosevelt, Utah 84066
 P: (435) 722-8267

Project: 2307-006 Daggett County Health Clinic
 Manilla, Utah

RFI #40: LINE SETS

Revision	0	Status	Closed on 02/02/26
To	Bart Jensen (Jones & DeMille Engineering) Krystal Watts (Campbell Architecture)	From	Hady Hadfield (Hadfield Construction)
Date Initiated	Jan 21, 2026	Due Date	Jan 29, 2026
Location		Project Stage	
Cost Impact		Schedule Impact	
Spec Section		Cost Code	
Drawing Number		Reference	
Linked Drawings			
Received From			
Copies To	Jade Hadfield (Hadfield Construction), Mark Jensen (Jones & DeMille Engineering), Krystal Watts (Campbell Architecture)		

Activity

Question *Question from Hady Hadfield Hadfield Construction on Wednesday, Jan 21, 2026 at 11:22 AM MST*
 Can the line sets be core drilled through the foundation into a window well per say or form it when we pour the pad and then run lines to the condensers from there?

Official Response *Response from Krystal Watts Campbell Architecture on Monday, Feb 2, 2026 at 11:32 AM MST*
 No, per our discussion the line sets are to be run in a 1 hour rated shaft located in the men's 107 and women's 106 restrooms. See Sheets A-104 for Wall Types, and A-401 for enlarged plans and dimensions. 2 line sets per shaft.

All Replies *Response from Krystal Watts Campbell Architecture on Monday, Feb 2, 2026 at 11:32 AM MST*
 No, per our discussion the line sets are to be run in a 1 hour rated shaft located in the men's 107 and women's 106 restrooms. See Sheets A-104 for Wall Types, and A-401 for enlarged plans and dimensions. 2 line sets per shaft.



AIA® Document G709™ – 2018

Proposal Request

PROJECT: *(name and address)*
Daggett County Health, Business and
Community Center
105 North 100 West
Manilla, Utah 84046

CONTRACT INFORMATION:
Contract For: General Construction

Date: 06-25-2025

Architect's Project Number: 2307-006
Proposal Request Number: PR 04

Proposal Request Date: 02/12/2026

OWNER: *(name and address)*
Daggett County Municipal Building
Authority
105 North 100 West
Manilla, Utah 84046

ARCHITECT: *(name and address)*
Campbell Architecture

775 W. Spring Creek Place, Suite #200a
Springville, Utah 84663

CONTRACTOR: *(name and address)*
Hadfield Construction LLC

2650 Washington Blvd. Se 205
Ogden, Utah 84401

The Owner requests an itemized proposal for changes to the Contract Sum and Contract Time for proposed modifications to the Contract Documents described herein. The Contractor shall submit this proposal within 14 (14) days or notify the Architect in writing of the anticipated date of submission.

(Insert a detailed description of the proposed modifications to the Contract Documents and, if applicable, attach or reference specific exhibits.)

A. Daggett County would like the addition of doors to access the storage area under each stairway. Both stairways are exit stairways and as such the storage rooms and the stairs are fire rated. In order for the storage under the stairs to be utilized, the following needs to be included:

1. 2 - 45 minute rated metal doors, trim and color to match plans. Contractor to verify sizes prior to ordering. See updated drawings, G-002, A-102, A-105, A-108, A-121, A-410, A-501.
2. Additional fire resistance is needed. See the above listed plans for details. Contact Architect with any questions.

B. Wall in X-ray room to have 2 studs removed and to have a curved curtain track used to allow for better circulation around the x-ray equipment. See sheet A-404 Enlarged Plans & Int. Elevations for details.

THIS IS NOT A CHANGE ORDER, A CONSTRUCTION CHANGE DIRECTIVE, OR A DIRECTION TO PROCEED WITH THE WORK DESCRIBED IN THE PROPOSED MODIFICATIONS.

REQUESTED BY THE ARCHITECT:

Krystal Watts, Architect
PRINTED NAME AND TITLE



Beacon | Rex Williams
 Ship To: 2770 S West Temple, SLC, UT 84115
 Mail To: PO Box 65462, SLC, UT 84165
 United States
 Phone: 801-486-4884
 Fax:

PROPOSAL

Page: 1
 Proposal No.: JOB000874
 Proposal Change No.: 002
 Customer P.O. No.: 0
 Proposal Date: 2/16/2026
 Customer ID: HAD200
 Salesperson: CURTIS PASIN
 Salesperson Phone:
 Salesperson Email: CurtisP@beaconcdl.com
 Project Manager: CP

Submitted To: HADFIELD CONSTRUCTION*
 JADE HADFIELD
 2650 WASHINGTON BLVD.
 SUITE 104
 Ogden, UT 84401

Job Name: DAGGETT COUNTY HEALTH, BUSINESS AND COMMUNITY CENTER

Item No.	Description	Unit	Quantity	Unit Price	Total Price
NSHMDOOR	STE HMD 3-0 x 7-0 4 RH F UL 45PP LF 16 A-60 PS H45 1 (61L) LDLIR 3/4 Opening 010B	EA	1	1,497.63	1,497.63
NSHI	5BB1HW X 4.5 X 4.5 X NRP 652 Opening 008B, 010B	EA	6	61.28	367.68
NSLO	ND10.LAT.626.626 626 Opening 008B, 010B	EA	2	594.88	1,189.76
NSLO	B661.R.626 626 Opening 008B, 010B	EA	2	301.11	602.22
NSHMF3SF	STE SGL HMF 3-0 x 7-0 RH 5 3/4 UL 45PP F 16 4 A-60 KD 2 DW DW Opening 008B	EA	1	591.62	591.62
NSHMDOOR	STE HMD 3-0 x 7-0 4 RH F UL 45PP LF 16 A-60 PS H45 1 (61L) LDLIR 3/4 Opening 008B	EA	1	1,497.63	1,497.63
NSHMF3SF	STE SGL HMF 3-0 x 7-0 RH 7 3/4 UL 45PP F 16 4 A-60 KD 2 DW DW Opening 010B	EA	1	586.21	586.21
COP SHIPPING	Ship to job site	EA	1	150.00	150.00

Accepted By: _____

Date: _____

Purchase Order No. _____

Subtotal: 6,482.75
 Sales Tax: 547.79
 Total: 7,030.54

PR 04

Self Performed Labor						
PS	Project Superintendant	1	Hrs	\$	106.00	\$ 106.00
PF	Project Foreman	4	Hrs	\$	86.00	\$ 344.00
C1	Carpenter	4	Hrs	\$	75.00	\$ 300.00
L	Laborer	4	Hrs	\$	45.00	\$ 180.00
TEK Owned Equipment						
Truck With tools	Truck with tools	1	Days	\$	147.00	\$ 147.00
Delivery	Salt Lake to Manila	1	Ls	\$	125.00	\$ 125.00
Materials						
2x6x16	Wheelright	15	LS	\$	11.03	\$ 165.45
					Cost Total	\$ 1,367.45
					Profit/Overhead (15%)	\$ 205.12
					Price Total	\$ 1,572.57



HD Build

Phone: 801-360-3264

Hadfield Construction LLC

Job Address:

105 North 1st West

Manila, UT 84046

Print Date: 2-20-2026

CO #3 - Daggett County HBC Center

Change Order ID: 0003

Here is our change order to do the 5/8" gyp under stairs and the fire retardant spary with 2 coats for the added 30 mins.

Items	Description	Price
CO #3, PR 04 - Gyp and Fire Retardant	Material: \$3,850 Drywall and mud Fire Retardant Spray 12 gal Labor: \$3,150 Rate \$75/hr Drywall 25 man hours Fire Retardant Spray 17 man hours P&O 15%: \$1050.00	\$8,050.00

Total price: \$8,050.00

Please approve this Change Order if you would like to confirm the adjustment to your original Scope of Work. By approving, you acknowledge the adjustment to the construction schedule and will be invoiced upon approval or in a subsequent draw.

I confirm that my action here represents my electronic signature and is binding.

Signature:

Date:

Print Name:



PCO 19 Date 2.26.2026
 Project Name Daggett County HBC Center Project Number 2307-006
 Agency Daggett County Municipal Building Authority Contract Number _____
 A/E Campbell Architecture

PCO Or CCD Number	Description of work Must include reasoning as to why the change occurred	Amount	Days
19	Changes required as per Fire Marshal	\$ 10,367.25	0
Total This Change Order		\$ 10,367.25	0

		Date	Days
Original Contract	\$ 5,320,000.00		
Total Previous Change Orders			
Total This Change order	\$ 10,367.25		0
Adjusted Contract	\$		

- This change order is issued under the following conditions:
1. This work is to be performed in strict accordance with the terms of the Contract Documents, including prior issued Change Orders and Construction Change Directives, except as modified by this Change Order.
 2. The rights of Hadfield Construction are not prejudiced.
 3. The Contractor agrees that the terms, contract sum, scope of the Work and time specified in this Change Order shall constitute the full accord and satisfaction, and complete adjustment to the Contract and includes all direct and indirect costs and effects related to, incidental to, a consequence of and/or reasonably implied from such change in the contract terms, sum, scope of the Work and time.
 4. Documents submitted with this Change Order are hereby incorporated as part of the Contract Documents for this Project.
 5. This change order is not effective until executed by the Agency below.
 6. Signature of the Contractor below indicates agreement herewith.

THE TERMS AND CONDITIONS OF THIS CHANGE ORDER ARE HEREBY ACCEPTED:

Contractor: Date: 2.26.2026
 Architect/Engineer _____
 Agency/Institution: _____

ESTIMATE

Hadfield Construction LLC
2650 Washington Blvd. Ste 205
Ogden, UT 84401

jade@hadfieldco.com
+1 (801) 300-0816
www.hadfieldco.com



Daggett County:HBC Center

Bill to
Daggett County
105 N 1st W
Manila, UT 84046

Ship to
Daggett County
105 N 1st W
Manila, Utah 84046

Estimate details

Estimate no.: 1726
Estimate date: 02/26/2026

#	Product or service	Description	Qty	Rate	Amount
1.		Daggett County PCO 19			
2.	02 Site Work	System Service Specialists	1	\$9,015.00	\$9,015.00
3.	02 Site Work	Hadfield Construction P&O 15%	1	\$1,352.25	\$1,352.25
				Total	\$10,367.25

Accepted date

Accepted by



**SYSTEM
SERVICE
SPECIALIST**

382 N Marshall Way
Layton, UT 84041
801.546.2243

Invoice

DATE	INVOICE #
2/5/2026	45500

BILL TO
Hadfield Construction LLC 2650 Washington Blvd Suite 205 Ogden, UT 84401

P.O. NO.	TERMS
	Due upon receipt

DESCRIPTION	QTY	RATE	AMOUNT
Dagget County Health, Business, and Community Center			
Change order for system piping rework due to change of ceiling and mechanical layout and additional requirements per the fire marshal.	1	9.015.00	9.015.00
Material: \$1,615 Labor: \$7,400 Sales Tax		7.25%	0.00
Thank you for your business.	E-mail	Payments/Credits	\$0.00
ar@systemservicespecialist.com		Balance Due	\$9,015.00



PCO 20 Date 3.02.2026
 Project Name Daggett County HBC Center Project Number 2307-006
 Agency Daggett County Municipal Building Authority Contract Number _____
 A/E Campbell Architecture

PCO Or CCD Number	Description of work Must include reasoning as to why the change occurred	Amount	Days
20	Cedar for all beams that are both vertical and horizontal on exterior of building that do not have a finish per the finish schedule	\$ 10,511.00	0
Total This Change Order		\$ 10,511.00	0

	Date	Days
Original Contract	\$ 5,320,000.00	
Total Previous Change Orders		
Total This Change order	\$ 10,511.00	0
Adjusted Contract	\$	

- This change order is issued under the following conditions:
1. This work is to be performed in strict accordance with the terms of the Contract Documents, including prior issued Change Orders and Construction Change Directives, except as modified by this Change Order.
 2. The rights of Hadfield Construction are not prejudiced.
 3. The Contractor agrees that the terms, contract sum, scope of the Work and time specified in this Change Order shall constitute the full accord and satisfaction, and complete adjustment to the Contract and includes all direct and indirect costs and effects related to, incidental to, a consequence of and/or reasonably implied from such change in the contract terms, sum, scope of the Work and time.
 4. Documents submitted with this Change Order are hereby incorporated as part of the Contract Documents for this Project.
 5. This change order is not effective until executed by the Agency below.
 6. Signature of the Contractor below indicates agreement herewith.

THE TERMS AND CONDITIONS OF THIS CHANGE ORDER ARE HEREBY ACCEPTED:

Contractor: Date: 3.02.2026
 Architect/Engineer _____
 Agency/Institution: _____

ESTIMATE

Hadfield Construction LLC
2650 Washington Blvd. Ste 205
Ogden, UT 84401

jade@hadfieldco.com
+1 (801) 300-0816
www.hadfieldco.com



Daggett County:HBC Center

Bill to

Daggett County
105 N 1st W
Manila, UT 84046

Ship to

Daggett County
105 N 1st W
Manila, Utah 84046

Estimate details

Estimate no.: 1729
Estimate date: 03/02/2026

#	Product or service	Description	Qty	Rate	Amount
1.		Daggett County PCO 20			
2.	02 Site Work	801 Construction	1	\$9,140.00	\$9,140.00
3.	02 Site Work	Hadfield Construction P&O 15%	1	\$1,371.00	\$1,371.00
				Total	\$10,511.00

Accepted date

Accepted by

INVOICE

801 Construction

901 East 8600 South
Sandy Ut 84094
USA
Mobile: 8018315260
801constructionut@gmail.com

Invoice #	309
Date	27 feb 2026
Due Date	27 feb 2026
Total	\$9,140.00

Invoice To:
Hadfield Construction
Dagget County Health
Change Order

#	Products	Quantity	Unit Price	Amount
1.	Cedar wrap columns Material	1	\$4,330.00	\$4,330.00
2.	Cedar wrap labor	1	\$3,000.00	\$3,000.00
3.	Stain material	1	\$510.00	\$510.00
4.	Stain Labor	1	\$1,300.00	\$1,300.00

	Quantity	4 Qty
	Sub Total	\$9,140.00
	Total	\$9,140.00

Gerardo Fragoso
Owner/Manager





PCO 21 Date 3.11.2026
 Project Name Daggett County HBC Center Project Number 2307-006
 Agency Daggett County Municipal Building Authority Contract Number _____
 A/E Campbell Architecture

PCO Or CCD Number	Description of work Must include reasoning as to why the change occurred	Amount	Days
21	Per PR 05	\$ 2,868.53	0
Total This Change Order		\$ 2,868.53	0

		Date	Days
Original Contract	\$ 5,320,000.00		
Total Previous Change Orders			
Total This Change order	\$ 2,868.53		0
Adjusted Contract	\$		

- This change order is issued under the following conditions:
1. This work is to be performed in strict accordance with the terms of the Contract Documents, including prior issued Change Orders and Construction Change Directives, except as modified by this Change Order.
 2. The rights of Hadfield Construction are not prejudiced.
 3. The Contractor agrees that the terms, contract sum, scope of the Work and time specified in this Change Order shall constitute the full accord and satisfaction, and complete adjustment to the Contract and includes all direct and indirect costs and effects related to, incidental to, a consequence of and/or reasonably implied from such change in the contract terms, sum, scope of the Work and time.
 4. Documents submitted with this Change Order are hereby incorporated as part of the Contract Documents for this Project.
 5. This change order is not effective until executed by the Agency below.
 6. Signature of the Contractor below indicates agreement herewith.

THE TERMS AND CONDITIONS OF THIS CHANGE ORDER ARE HEREBY ACCEPTED:

Contractor: Date: 3.11.2026
 Architect/Engineer _____
 Agency/Institution: _____

AIA[®] Document G709[™] – 2018

Proposal Request

PROJECT: *(name and address)*
Daggett County Health, Business and
Community Center
105 North 100 West
Manilla, Utah 84046

CONTRACT INFORMATION:
Contract For: General Construction

Date: 06-25-2025

Architect's Project Number: 2307-006
Proposal Request Number: PR 05

Proposal Request Date: 02/27/2026

OWNER: *(name and address)*
Daggett County Municipal Building
Authority
105 North 100 West
Manilla, Utah 84046

ARCHITECT: *(name and address)*
Campbell Architecture

775 W. Spring Creek Place, Suite #200a
Springville, Utah 84663

CONTRACTOR: *(name and address)*
Hadfield Construction LLC

2650 Washington Blvd. Se 205
Ogden, Utah 84401

The Owner requests an itemized proposal for changes to the Contract Sum and Contract Time for proposed modifications to the Contract Documents described herein. The Contractor shall submit this proposal within 14 (14) days or notify the Architect in writing of the anticipated date of submission.

(Insert a detailed description of the proposed modifications to the Contract Documents and, if applicable, attach or reference specific exhibits.)

A. Serving Room 119 to be modified as follows:

1. Roll-up door will not be installed. Credit due for framing, labor and overhead.
2. Additional base cabinets, upper cabinets and countertop to be added on north wall. See Sheet A-404

THIS IS NOT A CHANGE ORDER, A CONSTRUCTION CHANGE DIRECTIVE, OR A DIRECTION TO PROCEED WITH THE WORK DESCRIBED IN THE PROPOSED MODIFICATIONS.

REQUESTED BY THE ARCHITECT:

Krystal Watts, Architect

PRINTED NAME AND TITLE

ESTIMATE

Hadfield Construction LLC
2650 Washington Blvd. Ste 205
Ogden, UT 84401

jade@hadfieldco.com
+1 (801) 300-0316
www.hadfieldco.com



Daggett County:HBC Center
Bill to
Daggett County
105 N 1st W
Manila, UT 84046

Ship to
Daggett County
105 N 1st W
Manila, Utah 84046

Estimate details

Estimate no.: 1736
Estimate date: 03/11/2026

#	Product or service	Description	Qty	Rate	Amount
1.		Daggett County PCO 21			
2.	02 Site Work	Mapleleaf Cabinets	1	\$4,339.88	\$4,339.88
3.	02 Site Work	Western Industrial Door	1	-\$1,845.51	-\$1,845.51
4.	02 Site Work	Hadfield Construction P&O 15%	1	\$374.16	\$374.16
				Total	\$2,868.53

Accepted date

Accepted by



Mapleleaf Cabinets, Inc.

2554 S 3400 W
West Valley City, Utah 84119
(801) 262-7741
<https://mapleleafcabinets.com/>

Salesperson:
Estimator:

Proposal submitted to:

Hadfield Construction
2650 Washington Blvd
Ogden, Utah 84401-3623

Attention:

Jade Hadfield
jade@hadfieldco.com
Phone: (801) 300-0816

Job Information:

Job Name: Dagget County Health,
Business and Community
Center SO 12100
Job Location: Manila, Utah
Architect:
Bid Number: O-25-1505-001
Bid Date: 5/12/2025
Plan Date:
Spec Date:
Addenda:
Delivery Date: 1/19/2026

We Hereby Submit Our Proposal For:

Clarifications and Details:

Changes to Serving 117 per PR 05

We Propose to Furnish the Above for the Sum of:

Total Price: \$4,339.88

Scope of work:

Location	Drawing references	Products
CO per PR05	A-402	Cabinet.Base 1 dr 1 drw , Cabinet.Base 4 Drawer, Cabinet.Wall 2 Doors, SolidSurface.Top

Legal Conditions:



Bid Proposal

DATE: 2/24/2026

TO: Hadfield construction dagget county	Quoted By: Adam Milligan 7031 Commerce Park Drive Midvale, UT 84047 email - amilligan@westerndoorinc.com
---	--

PHONE:	Phone:801-390-1174
--------	--------------------

DATE	Prepared by	TERMS
2/24/2026	Adam Milligan	NET 30

QTY	UNIT	DESCRIPTION	UNIT PRICE	TOTAL
1	door assembly	new 6'0"x4'4" stainless steel counter door manually operated thumb screw locking inside square hood curtain guides and hood stainless steel 22 guage delivered to hadfield construction ogden	\$6,668.98	\$6,668.98

Questions? Call Adam 801-390-1174
Please reply to fax 801-566-3550

A 4% PROCESSING FEE WILL BE CHARGED TO ANY CREDIT/DEBIT CARD PAYMENT

SUBTOTAL	\$6,668.98
tax 7.45	\$496.84
FREIGHT	
4% PROCESSING FEE	
TOTAL	\$7,165.82
<i>Initial bid</i>	<i>\$9,011.33</i>

credit is \$1,845.51

ALL WIRING INCLUDING LOW VOLTAGE TO BE DONE BY OTHERS:

This is a quotation on the goods named, subject to the conditions noted below:

Industry standard and customary general liability, automobile liability and worker's compensation insurance limits apply. Special endorsements including but not limited to indemnification, waiver of subrogation, CG2037 and primary wording resulting in additional premium is at the expense of the general contractor or owner. Any deviation or alteration from the above specifications involving extra costs will be executed only upon written orders and will become an extra charge over and above this quotation. Our workers are covered by Workers Compensation Insurance, Liability and Property Damage Insurance. We may withdraw this proposal if not accepted within 7 days, and/or shipment made within 120 days.

Nevada License # 0076324 Utah License # 803-6677-5501

authorized by _____ date _____

accepted by _____ date _____



PCO	<u>22</u>	Date	<u>3.18.2026</u>
Project Name	<u>Daggett County HBC Center</u>	Project Number	<u>2307-006</u>
Agency	<u>Daggett County Municipal Building Authority</u>	Contract Number	<u>Campbell Architecture</u>
		A/E	<u>Campbell Architecture</u>

PCO Or CCD Number	Description of work Must include reasoning as to why the change occurred	Amount	Days
22	Per PR 06 Fur out elevator shaft and drywall, insulate areas in new cavaties created. Added backing for elevator shaft per TK Elevator. Remove and frame in door	\$ 5,637.19	0
Total This Change Order		\$ 5,637.19	0

		Date	Days
Original Contract	\$ 5,320,000.00		
Total Previous Change Orders			
Total This Change order	\$ 5,637.19		0
Adjusted Contract	\$		

This change order is issued under the following conditions:

1. This work is to be performed in strict accordance with the terms of the Contract Documents, including prior issued Change Orders and Construction Change Directives, except as modified by this Change Order.
2. The rights of Hadfield Construction are not prejudiced.
3. The Contractor agrees that the terms, contract sum, scope of the Work and time specified in this Change Order shall constitute the full accord and satisfaction, and complete adjustment to the Contract and includes all direct and indirect costs and effects related to, incidental to, a consequence of and/or reasonably implied from such change in the contract terms, sum, scope of the Work and time.
4. Documents submitted with this Change Order are hereby incorporated as part of the Contract Documents for this Project.
5. This change order is not effective until executed by the Agency below.
6. Signature of the Contractor below indicates agreement herewith.

THE TERMS AND CONDITIONS OF THIS CHANGE ORDER ARE HEREBY ACCEPTED:

Contractor: <u></u>	Date: <u>3.18.2026</u>
Architect/Engineer _____	
Agency/Institution: _____	

AIA Document G709 - 2018

Proposal Request

PROJECT: <i>(name and address)</i> Daggett County Health, Business and Community Center 105 North 100 West Manilla, Utah 84046	CONTRACT INFORMATION: Contract For: General Construction Date: 06-25-2025	Architect's Project Number: 2307-006 Proposal Request Number: PR 06 Proposal Request Date: 03/11/2026
OWNER: <i>(name and address)</i> Daggett County Municipal Building Authority 105 North 100 West Manilla, Utah 84046	ARCHITECT: <i>(name and address)</i> Campbell Architecture 775 W. Spring Creek Place, Suite #200a Springville, Utah 84663	CONTRACTOR: <i>(name and address)</i> Hadfield Construction LLC 2650 Washington Blvd. Sc 205 Ogden, Utah 84401

The Owner requests an itemized proposal for changes to the Contract Sum and Contract Time for proposed modifications to the Contract Documents described herein. The Contractor shall submit this proposal within (14) days or notify the Architect in writing of the anticipated date of submission.

(Insert a detailed description of the proposed modifications to the Contract Documents and, if applicable, attach or reference specific exhibits.)

A. Elevator Shaft

1. Elevator shaft walls, as shown on updated attached sheets A-321, A-322, A-410, will have a 70 degree return wall at the three walls shown on drawings per the TK elevator rep. See plans for details.

2. Door into Elevator shaft will be removed, wall will be infilled to match wall type (1 hour rated) of surrounding walls.

B. Framing for Modern Fold Partition walls to be updated as per Modern Folds request and response per RFI 55.

1. Community Room Track Changes:

We take no exception to the addition of two (2) 2x6 members to each of the two existing headers, providing the necessary bearing and mounting surface for the Modernfold partition wall track. All supplemental members shall be fastened to the existing headers using 1/4" Simpson SDS screws, staggered, at 6" on center.

2. Basement Dance Room Track Changes:

The Modernfold wall track in the basement dance room shall be framed and installed per the detail referenced in RFI 046. The 1/2" threaded rod used to attach the track to the structure may be lengthened as required to accommodate the difference in elevation between the bottom of the truss and the 9'-0" finished curtain height.

The resulting space between the top of the Modernfold curtain wall and the bottom of the truss structure shall be enclosed with non-structural light framing, construction and finish to be consistent with the surrounding conditions.

THIS IS NOT A CHANGE ORDER, A CONSTRUCTION CHANGE DIRECTIVE, OR A DIRECTION TO PROCEED WITH THE WORK DESCRIBED IN THE PROPOSED MODIFICATIONS.

REQUESTED BY THE ARCHITECT:

Krystal Watts, Architect
PRINTED NAME AND TITLE

ESTIMATE

Hadfield Construction LLC
2650 Washington Blvd, Ste 205
Ogden, UT 84401

jade@hadfieldco.com
+1 (801) 300-0816
www.hadfieldco.com



Daggett County:HBC Center

Bill to

Daggett County
105 N 1st W
Manila, UT 84046

Ship to

Daggett County
105 N 1st W
Manila, Utah 84046

Estimate details

Estimate no.: 1738

Estimate date: 03/18/2026

#	Product or service	Description	Qty	Rate	Amount
1.		Daggett County PCO 22			
2.	02 Site Work	GCM Builders	1	\$4,901.90	\$4,901.90
3.	02 Site Work	Hadfield Construction P&O 15%	1	\$735.29	\$735.29
				Total	\$5,637.19

Accepted date

Accepted by

ESTIMATE

GCM Builders LLC
6984 E 200 S
Huntsville, UT 84317-9809

creed@gcmbuilders.com
www.gcmbuilders.com

Bill to

Hadfield Construction
Hadfield Cons.
2650 Washington Blvd. Ste. 205
Ogden, UT 84401

Ship to

Daggett County RFI 55

Estimate details

Estimate no.: 1166
Estimate date: 03/13/2026

#	Product or service	Description	Qty	Rate	Amount
1.	Services	Labor and material provided to build sloped walls in elevator pit, fill in door going into pit, install additional 2x6's to existing header and swap out the hangers on each end. Price includes room and board.	1	\$4,266.28	\$4,266.28
2.	Services	Profit and overhead.	1	\$635.62	\$635.62

\$ 4,901.90

Accepted date

Accepted by



Wheelwright Lumber Co.
 3127 South Midland Drive
 Ogden UT 84401
 801-627-0850
 Fax: 801-627-9933



QUOTE

2603-011736

PAGE 1 OF 1

SOLD TO
PILLAR & PINE BUILDERS# 6984 E 200 S HUNTSVILLE UT 84317

JOB ADDRESS
SHOP & MISC JOBS 801-389-9771

ACCOUNT	JOB
196285	1
CREATED ON	03/16/2026
EXPIRES ON	03/31/2026
BRANCH	1000
CUSTOMER PO#	
STATION	W26
CASHIER	MCKAY
SALESPERSON	MCKAY
ORDER ENTRY	MCKAY
MODIFIED BY	

Thank you for your business.
 Special order items are non
 refundable. FED ID 87-0193460

Item	Description	D	Quantity	UM	Price	Per	Amount
2608ACQ	2X6-08 CA-C BROWN EXT. TREATED		3	EA	11.5400	EA	34.62
2610ACQ	2X6-10 CA-C BROWN EXT. TREATED		1	EA	14.4200	EA	14.42
2608F	2X6-08 #2&btr White Fir		22	EA	5.2900	EA	116.38
2610F	2X6-10 #2&btr White Fir		1	EA	7.0200	EA	7.02
6437768	PL400 VOC CONST ADHESIVE 29OZ		1	EA	7.3800	EA	7.38
SOSIMPSON	HGUS26-4		2	EA	52.4600	EA	104.92
					Subtotal		284.74
QUOTE ONLY Prices good for 15 days from date of quote. We cannot assume responsibility for any variation in quantities actually used which differ from estimate-please add a figure to cover overages, hardware & unknowns.					OGD 7.25%	Sales Tax	20.64
					Total		305.38

Buyer:

Signature



Document G701® – 2017

Change Order

PROJECT: <i>(Name and address)</i> Daggett County Health, Business and Community Center 105 North 100 West Manilla, Utah 84046	CONTRACT INFORMATION: Contract For: General Construction Date: 06-25-2025	CHANGE ORDER INFORMATION: Change Order Number: 011 Date: 03/25/2026
OWNER: <i>(Name and address)</i> Daggett County Municipal Building Authority 105 North 100 West Manilla, Utah 84046	ARCHITECT: <i>(Name and address)</i> Campbell Architecture 46 North 200 East St. George, Utah 84770	CONTRACTOR: <i>(Name and address)</i> Hadfield Construction LLC 2650 Washington Blvd, Se 205 Ogden, Utah 84401

THE CONTRACT IS CHANGED AS FOLLOWS:

(Insert a detailed description of the change and, if applicable, attach or reference specific exhibits. Also include agreed upon adjustments attributable to executed Construction Change Directives.)

1. Refer to attached PCO's 11, 12.

The original Contract Sum was	\$ 5,320,000.00
The net change by previously authorized Change Orders	\$ 837,290.24
The Contract Sum prior to this Change Order was	\$ 6,157,290.24
The Contract Sum will be increased by this Change Order in the amount of	\$ 11,318.26
The new Contract Sum including this Change Order will be	\$ 6,168,608.50

The Contract Time will be unchanged by zero (0) days.
The new date of Substantial Completion will be September 2, 2026

NOTE: This Change Order does not include adjustments to the Contract Sum or Guaranteed Maximum Price, or the Contract Time, that have been authorized by Construction Change Directive until the cost and time have been agreed upon by both the Owner and Contractor, in which case a Change Order is executed to supersede the Construction Change Directive.

NOT VALID UNTIL SIGNED BY THE ARCHITECT, CONTRACTOR AND OWNER.

Campbell Architecture	Hadfield Construction LLC	Daggett County Municipal Building Authority
_____ ARCHITECT <i>(Firm name)</i>	_____ CONTRACTOR <i>(Firm name)</i>	_____ OWNER <i>(Firm name)</i>
<i>Krystal Watts</i>	<i>Jade Hadfield</i>	
_____ SIGNATURE	_____ SIGNATURE	_____ SIGNATURE
Krystal Watts, Architect	Jade Hadfield, Managing Member	Jesse Platt, Project Manager
_____ PRINTED NAME AND TITLE	_____ PRINTED NAME AND TITLE	_____ PRINTED NAME AND TITLE
Mar 25 2026		
_____ DATE	_____ DATE	_____ DATE



PCO 11 Date 2.03.2026
 Project Name Daggett County HBC Center Project Number 2307-006
 Agency Daggett County Municipal Building Authority Contract Number _____
 A/E Campbell Architecture

PCO Or CCD Number	Description of work Must include reasoning as to why the change occurred	Amount	Days
11	Pocket for curtain wall per RFI 47	\$ 3,068.98	0
Total This Change Order		\$ 3,068.98	0

	Original Contract	Date	Days
	\$ 5,320,000.00		
	Total Previous Change Orders		
	Total This Change order		0
	Adjusted Contract		

- This change order is issued under the following conditions:
1. This work is to be performed in strict accordance with the terms of the Contract Documents, including prior issued Change Orders and Construction Change Directives, except as modified by this Change Order.
 2. The rights of Hadfield Construction are not prejudiced.
 3. The Contractor agrees that the terms, contract sum, scope of the Work and time specified in this Change Order shall constitute the full accord and satisfaction, and complete adjustment to the Contract and includes all direct and indirect costs and effects related to, incidental to, a consequence of and/or reasonably implied from such change in the contract terms, sum, scope of the Work and time.
 4. Documents submitted with this Change Order are hereby incorporated as part of the Contract Documents for this Project.
 5. This change order is not effective until executed by the Agency below.
 6. Signature of the Contractor below indicates agreement herewith.

THE TERMS AND CONDITIONS OF THIS CHANGE ORDER ARE HEREBY ACCEPTED:

Contractor: _____ Date: 2.03.2026
 Architect/Engineer _____
 Agency/Institution: _____

ESTIMATE

Hadfield Construction LLC
2650 Washington Blvd, Ste 205
Ogden, UT 84401

jade@hadfieldco.com
+1 (801) 300-0816
www.hadfieldco.com



Daggett County:HBC Center

Bill to
Daggett County
105 N 1st W
Manila, UT 84046

Ship to
Daggett County
105 N 1st W
Manila, Utah 84046

Estimate details

Estimate no.: 1698
Estimate date: 02/03/2026

#	Product or service	Description	Qty	Rate	Amount
1.		Daggett County PCO 11			
2.	02 Site Work	TEK Construction	1	\$2,841.65	\$2,841.65
3.	02 Site Work	Hadfield Construction P&O 15%	1	\$227.33	\$227.33
				Total	\$3,068.98

Accepted date

Accepted by



Jones & DeMille Engineering
 520 West Hwy 40
 Roosevelt, Utah 84066
 P: (435) 722-8267

Project: 2307-006 Daggett County Health Clinic
 Manilla, Utah

RFI #47: POCKET FOR CURTAIN WALL

Revision	0	Status	Closed on 01/26/26
To	Krystal Watts (Campbell Architecture)	From	Hady Hadfield (Hadfield Construction)
Date Initiated	Jan 23, 2026	Due Date	Feb 2, 2026
Location		Project Stage	
Cost Impact		Schedule Impact	
Spec Section		Cost Code	
Drawing Number		Reference	
Linked Drawings			
Received From			
Copies To	Hady Hadfield (Hadfield Construction), Jade Hadfield (Hadfield Construction), Mark Jensen (Jones & DeMille Engineering), Krystal Watts (Campbell Architecture)		

Activity

Question **Question from Hady Hadfield Hadfield Construction on Thursday, Jan 22, 2026 at 02:40 PM MST**
 The closet/pocket for the curtain wall was framed 3' 6" which shows on the plan. The cut sheets from the manufacturer shows this closet/pocket needs to be framed 4' 8". Krystal and I have talked about it on how to frame it. This needs to be a change order.
 Please give direction on how this needs to be handled.

Attachments
 IMG_4250.jpg

Official Response **Response from Krystal Watts Campbell Architecture on Friday, Jan 23, 2026 at 12:33 PM MST**
 See A-101 for updated plan for the framing for recess for the folding partition wall. Please submit a PCO for the change.

All Replies **Response from Krystal Watts Campbell Architecture on Friday, Jan 23, 2026 at 12:33 PM MST**
 See A-101 for updated plan for the framing for recess for the folding partition wall. Please submit a PCO for the change.

RFI #47

Self Performed Labor						
PS	Project Superintendant	1	Hrs	\$	106.00	\$ 106.00
PF	Project Foreman	6	Hrs	\$	86.00	\$ 516.00
C1	Carpenter	6	Hrs	\$	75.00	\$ 450.00
C1	Carpenter	6	Hrs	\$	45.00	\$ 270.00
L	Laborer	6	Hrs	\$	45.00	\$ 270.00
Per Deim						
Per Deim	Crew of (4) Per Day. Rates used are provided by the GSA Standard of \$178 Ea	1	Days	\$	712.00	\$ 712.00
TEK Owned Equipment						
Truck With tools	Truck with tools	1	Days	\$	147.00	\$ 147.00
					Cost Total	\$ 2,471.00
					Profit/Overhead (15%)	\$ 370.65
					Price Total	\$ 2,841.65



PCO 12 Date 2.04.2026
 Project Name Daggett County HBC Center Project Number 2307-006
 Agency Daggett County Municipal Building Authority Contract Number _____
 A/E Campbell Architecture

PCO Or CCD Number	Description of work Must include reasoning as to why the change occurred	Amount	Days
12	Per RFI 46 additional backing and blocking for partition wall	\$ 8,249.28	0
Total This Change Order		\$ 8,249.28	0

	Original Contract	Date	Days
	\$ 5,320,000.00		
Total Previous Change Orders			
Total This Change order	\$ 8,249.28		0
Adjusted Contract	\$		

- This change order is issued under the following conditions:
1. This work is to be performed in strict accordance with the terms of the Contract Documents, including prior issued Change Orders and Construction Change Directives, except as modified by this Change Order.
 2. The rights of Hadfield Construction are not prejudiced.
 3. The Contractor agrees that the terms, contract sum, scope of the Work and time specified in this Change Order shall constitute the full accord and satisfaction, and complete adjustment to the Contract and includes all direct and indirect costs and effects related to, incidental to, a consequence of and/or reasonably implied from such change in the contract terms, sum, scope of the Work and time.
 4. Documents submitted with this Change Order are hereby incorporated as part of the Contract Documents for this Project.
 5. This change order is not effective until executed by the Agency below.
 6. Signature of the Contractor below indicates agreement herewith.

THE TERMS AND CONDITIONS OF THIS CHANGE ORDER ARE HEREBY ACCEPTED:

Contractor: Date: 2.4.2026
 Architect/Engineer _____
 Agency/Institution: _____



RFI #46: Additional Info for operable walls

Revision	0	Status	Closed on 01/26/26
To	Seth Robertson (Jones & DeMille Engineering) Krystal Watts (Campbell Architecture)	From	Hady Hadfield (Hadfield Construction)
Date Initiated	Jan 23, 2026	Due Date	Feb 2, 2026
Location		Project Stage	
Cost Impact		Schedule Impact	
Spec Section		Cost Code	
Drawing Number		Reference	
Linked Drawings	S-105 , S-502 , S-102		
Received From			
Copies To	Hady Hadfield (Hadfield Construction), Jade Hadfield (Hadfield Construction), Mark Jensen (Jones & DeMille Engineering), Krystal Watts (Campbell Architecture)		

Activity

Question **Question from Hady Hadfield Hadfield Construction on Thursday, Jan 22, 2026 at 03:12 PM MST**
 Need additional info and support specs and details for operable wall in dance room and additional framing details for community room operable wall storage closet

Attachments
 cut sheet for curtain.pdf

Official Response

Response from Seth Robertson Jones & DeMille Engineering on Friday, Jan 23, 2026 at 10:07 AM MST
 Partition wall track support details have been updated through markups on the structural drawings in Procore and linked to this RFI. These updated details are to better align with the provided cutsheet from Modernfold. Additional framing was required for the track in the pocket area on the main floor. Updated details and framing information can be found on sheets S-102, S-105, S-502 and S-503 in Procore.

All Replies

Response from Seth Robertson Jones & DeMille Engineering on Friday, Jan 23, 2026 at 10:07 AM MST
 Partition wall track support details have been updated through markups on the structural drawings in Procore and linked to this RFI. These updated details are to better align with the provided cutsheet from Modernfold. Additional framing was required for the track in the pocket area on the main floor. Updated details and framing information can be found on sheets S-102, S-105, S-502 and S-503 in Procore.

ESTIMATE

Hadfield Construction LLC
2650 Washington Blvd. Ste 205
Ogden, UT 84401

jade@hadfieldco.com
+1 (801) 300-0816
www.hadfieldco.com



Daggett County:HBC Center

Bill to

Daggett County
105 N 1st W
Manila, UT 84046

Ship to

Daggett County
105 N 1st W
Manila, Utah 84046

Estimate details

Estimate no.: 1701

Estimate date: 02/04/2026

#	Product or service	Description	Qty	Rate	Amount
1.		Daggett County PCO 12			
2.	02 Site Work	TEK Construction	1	\$7,173.29	\$7,173.29
3.	02 Site Work	Hadfield Construction P&O 15%	1	\$1,075.99	\$1,075.99
				Total	\$8,249.28

Accepted date

Accepted by

RFI #46

Self Performed Labor					
PS	Project Superintendant	2	Hrs	\$ 106.00	\$ 212.00
W.	Welder/Fabricator	4	Hrs	\$ 110.00	\$ 440.00
PF	Project Foreman	15	Hrs	\$ 86.00	\$ 1,290.00
C1	Carpenter	15	Hrs	\$ 75.00	\$ 1,125.00
C1	Carpenter	15	Hrs	\$ 45.00	\$ 675.00
L	Laborer	15	Hrs	\$ 45.00	\$ 675.00
Per Deim					
Per Deim	Crew of (4) Per Day. Rates used are provided by the GSA Standard of \$178 Ea	1	Days	\$ 712.00	\$ 712.00
TEK Owned Equipment					
Truck With tools	Truck with tools	2	Days	\$ 147.00	\$ 294.00
Delivery	Salt Lake to Manila	1	Ls	\$ 350.00	\$ 350.00
Materials					
4"x4"x1/4" Plate	Triple S Steel	1	LS	\$ 91.80	\$ 91.80
5"x3/8 Bolts	Home Depot	8	Ea	\$ 2.21	\$ 17.68
2x4x20	Home Depot	6	Ea	\$ 14.18	\$ 85.08
2x10x16	Home Depot	8	Ea	\$ 32.27	\$ 258.16
Hangers	Home Depot	4	Ea	\$ 2.98	\$ 11.92
				Cost Total	\$ 6,237.64
				Profit/Overhead (15%)	\$ 935.65
				Price Total	\$ 7,173.29



7485 N 3600 W

Honeyville, UT 84314

(801) 731-5240 Fax (888) 867-1845

Paul Groberg cell# 435-237-9591 email: patriotconstructionutah@gmail.com

DJ Water Treatment Plant CO 5

To: Bryan

Date: 3/24/26

Patriot Construction is pleased to provide the following quote for the following work:
Roofing

1. Option 2 Roof (Pitt Roofing) \$65,685.00
2. Soffit & Fascia (Pitt Roofing) \$3,950.00
3. Profit/Markup: \$6,963.50

FOR A TOTAL QUOTE OF.....\$76,598.50

This proposal will remain open for 60 days. Upon acceptance of this Proposal and upon issuance of a Purchase Order, this quoted price shall remain fixed for the duration of this project, subject to any Change Orders which are required for any additional work outside the scope of this project.

Authorized Signature: _____ Dated: _____

This proposal is agreed to and accepted by:

***Of our People, By our People,
FOR YOUR PEOPLE***



519 S

PITT ROOFI NG

1500 E VERNAL, UT 84078
PHONE: 435-789-6898 EMAIL:

PITTROOFINGINC@OUTLOOK.COM

Patriot Construction
Dutch John Water Treatment Plant
Attn. Braxton
801-458-4901

Change Order #1
Install Solid Aluminum soffit. \$3950.00

If you have any questions, please feel free to contact Stacy at 435-789-6898



PITT ROOFI NG

519 S 1500 E VERNAL, UT
84078
PHONE: 435-789-6898 EMAIL:
pittroofinginc@outlook.com

Patriot Construction
January 30, 2026
Braxton
801-458-4901

Dutch John Water Treatment Plant Roof @ 839 Maintenance Rd.

Current roof is approximately 3000 square feet & 42 years old. The roof consists of 1" thick built-up roof (Coppers Cold Tar roofing system which is no longer made due to carcinogens), 2-1/2" extruded polystyrene by Dowe Chemical (Irma System - inverted roof mopped to concrete deck), 8-ounce Geomat, & 1" crushed rock. The roof edges consist of 24-gauge galvanized gravel stops, scuppers, conductor heads, and down spouts.

Due to the age of the roof and the deteriorating flashing, we recommend a new roof rather than trying to do repairs. See our 2 new roof options below.

Option 1

Roof - Tear off existing roofing down to concrete decking, adhere new 1/8" ISO taper system to deck with Carlisle 2-part urethane adhesive, adhere new 3" ISO with 2-part with Carlisle 2-part urethane adhesive, install new 1/2" DensDeck Prime, and adhere new white 80-mil TPO membrane with low VOC bonding adhesive. Price includes a 30-year NDL manufacturer warranty which covers winds up to 100mph. Metal edge will not be covered under the warranty due to manufacturer specifications that need to be met for warranty.

Edge Detail - Raise up current nailer system by 4-5", install new white TPO clad metal fascia & scupper, and manufacture/install new outside conductor head & down spouts in the color of your choice.

Total cost for option 1 = \$49,825.00

Option 2

Roof - Tear off existing roofing down to concrete decking, adhere new 1/8" ISO taper system to deck with Carlisle 2-part urethane adhesive, adhere new 3" ISO with 2-part with Carlisle 2-part urethane adhesive, install new 1/2" DensDeck Prime, and adhere new black 90-mil EPDM membrane with low VOC bonding adhesive. Price includes a 30-year NDL manufacturer warranty

which covers winds up to 100mph. Metal edge will not be covered under the warranty due to manufacturer specifications that need to be met for warranty.

Edge Detail - Raise up current nailer system by 4-5", install new 24-gauge prefinished metal fascia & scupper in the color of your choice, and manufacture/install new outside conductor head & down spouts in the color of your choice.

Total cost for option 2 = \$65,685.00

Please note the following*

- * The metal edge is not covered under the manufacturer's warranty.
- * Pitt Roofing labor warranty is 2 years on the TPO system and 5 years for the EDPM system.
- * Any hidden damage to the concrete roof system that needs to be repaired to move forward with the new one will be billed at cost plus.

By signing below, I confirm that I have read the details and that I accept this quote as a contract between myself and Pitt Roofing, Inc.

Signature _____ Date _____

Printed Name _____ Title _____

If you have any questions, please call Stacy Galley at 435-789-6898.

Thank you and we look forward to working with you!



WORK RELEASE NO. 2026-1 COVER SHEET

**DAGGETT COUNTY/DUTCH JOHN
WASTEWATER IMPROVEMENTS PROJECT 2026**

DAGGETT COUNTY
PO BOX 219
MANILA, UT 84046

EXECUTION AND EFFECTIVE DATE

This Work Release No. 2026-1 has been executed by the duly authorized representatives of the parties and shall be effective as of the date of execution by CLIENT.

SUNRISE ENGINEERING, LLC ("SE")

DAGGETT COUNTY ("CLIENT")

Aaron Averett

By: _____

By: _____

Aaron Averett

Name: _____

Name: _____

Service Center Manager

Title: _____

Title: _____

March 19, 2026

Date: _____

Date: _____

WORK RELEASE NO. 2026-1

This Work Release is entered into by and between DAGGETT COUNTY (CLIENT) and SUNRISE ENGINEERING, LLC (SE).

RECITAL

Pursuant to Article 1 of the Agreement for Engineering and Technical Services, dated the 5th of January 2021, hereinafter referred to as the "Agreement", CLIENT and SE desire to identify certain services and work to be performed by SE pursuant to the Agreement. CLIENT intends to retain general professional services for which SE agrees to perform various professional services.

ARTICLES

ARTICLE 1. THE PROJECT

CLIENT's Project for which CLIENT has engaged SE to perform the services is generally described as follows:

The Dutch John Wastewater Improvements Project (2026) is intended to address existing sewer line and manhole deficiencies within the system. The project will include repairing, replacing, and lining existing sewer lines and laterals as well as repairs to manholes and installation of new manholes.

ARTICLE 2. SCOPE OF WORK

- 1. Preliminary Engineering Services** – SE will provide preliminary planning and administrative services as follows:
 - a. Assist the CLIENT with project planning, cost estimating, consideration of alternatives, to include attending meetings with the CLIENT, and other stakeholders to assist with defining and developing the project.
 - b. SE will assist with project administration and facilitation of the project and will provide coordination with the funding agency and project stakeholders to assist with the transition from the funding phase to the project design phase.

- 2. Engineering Design Services** – SE will provide engineering services for the proposed sewer improvements as follows:
 - a. Preliminary Engineering Design – Preliminary engineering services will include:
 - i. Perform necessary engineering design to create preliminary plan sheets for the layout of required improvements including locations for lining, spot repairs, sewer line replacements, lateral replacements, and manhole upgrades/replacements as defined in the Wastewater PER and funding application.
 - ii. Prepare the GIS project map for use in collecting project specific GPS data and for documentation of contract record drawing conditions during construction.

- iii. Provide an updated Engineer's Opinion of Probable Cost (EOPC) for the proposed improvements.
- iv. Meet with the CLIENT for a 30% Design Review meeting to review the preliminary plans and receive comments and concurrence prior to moving to the Final Design phase.
- v. Provisions:
 - 1. CLIENT shall provide assistance to SE for locating existing system components, to the best of CLIENT's knowledge.

b. Final Engineering Design

- i. Final Design will include final design drawings, specifications, and contract documents for the design elements listed above and concurred by the CLIENT in the preliminary design phase. SE will perform necessary detail design to show the character and scope of the work to be performed by contractors on the project.
- ii. SE will prepare technical specifications and contract documents for use in soliciting bids for the project.
- iii. SE will facilitate design reviews with CLIENT at the 60% and 90% design stages.
- iv. SE will submit final drawings and contract documents to the Division of Environmental Quality (DEQ) for plan review if necessary. Comments from the DEQ will be addressed and a bid set of drawings and contract documents will be prepared.

c. Provisions

- i. Environmental and cultural clearances are excluded from the scope of services but may be added as an additional service if requested by CLIENT or required by regulatory agencies.
- ii. It is understood that all repairs and replacements will need to be installed within public rights of way or within easements on private properties.

3. Bid Phase Services – Following final approval of the construction drawings and contract documents, SE will provide the following bid phase services based upon one bid solicitation for the sewer improvements:

- a. SE will provide assistance to the CLIENT during the bidding and contractor selection phase of the project as follows:
 - i. Conduct a pre-bid site visit as applicable
 - ii. Respond to bidders' requests for information
 - iii. Prepare addenda to the contract documents as required
 - iv. Assist in the bid opening, review the bids, review references, and provide a recommendation to the CLIENT for the award of the contract.
 - v. Prepare a conformed set of contract documents, to include all addenda material, and provide these documents to the CLIENT and the selected bidder.

- 4. Construction Phase Services** - Following the bidding and contractor selection phase, SE will provide construction engineering services during the construction phases. Neither SE nor CLIENT assume responsibility for construction means, methods, techniques, sequences or procedures, or for safety procedures, precautions and programs employed by CONTRACTOR, any subcontractor, their employees, or any material or equipment suppliers. SE'S undertaking hereunder shall not relieve CONTRACTOR'S obligation to perform the work in conformity with the Contract Documents, design drawings, and specifications in an acceptable manner. SE does not guarantee CONTRACTOR's performance or commitments to CLIENT. At the CLIENT's request, the SE may provide some or all of the following services:
- a. Conduct a preconstruction meeting.
 - b. Conduct regular construction meetings with the contractor and CLIENT.
 - c. Review for conformance with design concept and approve if acceptable any necessary shop and working drawings furnished by CONTRACTOR.
 - d. Provide construction observation as requested by CLIENT. Such observation shall not relieve CONTRACTOR in any way from its obligations and responsibilities under its Contract. The Observer will be qualified for the work, and his duties will include but may not be limited to the following:
 - i. Observe CONTRACTORS progress and quality of the work to determine if the work generally conforms to the Contract Documents.
 - ii. Issue immediate written memoranda of noncompliance to the CONTRACTOR, CLIENT, and Project Engineer when the Observer determines CONTRACTOR'S work to be defective or deficient.
 - iii. Report regularly to the Project Engineer and keep him advised as to work progress and defects and deficiencies in the work of CONTRACTOR.
 - e. Coordinate with independent materials testing firm for the receipt and review of materials testing reports.
 - i. The furnishing of materials testing services is excluded from this scope of work. SE assumes no responsibility for the accuracy or completeness of materials testing and reporting by the independent materials testing firm.
 - f. Review CONTRACTOR's applications for progress and final payment and, after review, submit to CLIENT for approval and payment.
 - g. On a timely basis and as needed prepare and recommend change orders to the construction contract for acceptance by CONTRACTOR, and for written approval of CLIENT, lenders, and approving agencies as applicable, and subsequent issuance of the approved change orders during the course of construction.
 - h. Make a final review prior to the issuance of any written notice of substantial completion of all applicable construction.
 - i. Recommend to the Owner that the work is substantially complete and issue the Certification of Substantial Completion and Final Certificate of Payment.
 - j. Prepare "Contract Record Drawings" showing details of construction including changes made during the construction process, which SE considers significant.

- k. Provision – the estimated budget for construction engineering and construction observation services included in the compensation section is based on a 90-calendar day construction period with minimal observation. Actual compensation may be more or less than the estimated budgeted amounts based on the actual duration of the construction period and the actual services requested by the CLIENT.

5. Additional Engineering Services – The following engineering services are not included under previous phases but may be added as part of the services rendered under this contract. These services may be provided upon written authorization from CLIENT and agreement on additional compensation. Funding application services beyond the services described in the scope of work above.

a. Additional Engineering Services – The following engineering services are not included under previous phases but may be added as part of the services rendered under this contract. These services may be provided upon written authorization from CLIENT and agreement on additional compensation. Funding application services beyond the services described in the scope of work above.

- i. Searching out property owners and negotiating for land and easement rights and subordination agreements, property surveys, property plats, property descriptions, and abstracting above and beyond that required for the original project.
- ii. Laboratory tests, detailed water quality tests, well tests, borings, hydraulic, soils investigations, water quality studies, or other studies recommended by SE and approved by CLIENT.
- iii. Environmental studies required to obtain environmental clearance from any funding agency or government agency beyond the services described in the scope of work above.
- iv. Appearances before courts or boards on matters of litigation related to the project.
- v. User rate studies, capital facilities planning, engineer's opinions of probable cost beyond those services described in the scope of work above.
- vi. Provide land use planning, housing planning, environmental planning, policy writing, etc. services as requested by CLIENT, these may include:
 - 1. Updating Land Use Code, Zoning and Subdivision Ordinances
 - 2. Reviewing and Processing New Development Applications and Permits
 - 3. Preparing planning and zoning agenda items for Planning Commission and Town Council meetings
 - 4. Supporting Planning Commission and Town Council meetings

b. Provide other miscellaneous services as requested by CLIENT.

It is generally intended that specific, large-budget assignments or projects will be completed by SE for CLIENT at CLIENT's request under separate, distinct work releases.

ARTICLE 3. CLIENT RESPONSIBILITIES

CLIENT's responsibilities will be as follows:

1. Access to Property:
 - a. CLIENT will arrange for access to and make all provisions for SE to enter upon public and private property as required by SE to perform its services.
2. Notices:
 - a. CLIENT will give prompt written notice to SE, whenever CLIENT becomes aware of developments that affect the scope of timing of the Engineering Services.
3. Access to Records:
 - a. CLIENT will make available to SE those records designated by SE as being necessary for the development of the PROJECT.
4. CLIENT will contact private property owners from whom the CLIENT will need to obtain easements and will negotiate said easements with the property owners. Upon receipt of the executed easements, CLIENT will record the easements at the county recorder's office and will provide copies of the recorded easements to SE.
5. CLIENT will locate and uncover, unbury, or otherwise mark sewer system vaults, manholes, or other components that are currently covered or buried, and those for which the location is not readily apparent, as required for the work described in the scope of services above.

ARTICLE 4. PERIOD OF PERFORMANCE OF WORK

Work is to begin when released by CLIENT and may continue for the duration of Contract.

1. Item 1 – Preliminary Engineering Services will be completed within 30 days of the notice to proceed being given by the CLIENT.
2. Item 2 – Sewer Improvements Design will begin following the notice to proceed given by the CLIENT. All tasks will be completed within 60 days of the notice to proceed. If new easements are needed that will affect the determination of alignments, this timeline may be extended to accommodate CLIENT's obtaining easements.
3. Item 3 – Bid Phase services will continue for a duration of 30 days. It is anticipated that a construction contract will be executed following the bid phase.
4. Item 4 – Construction Phase Services will begin following the bid phase and selection of a contractor. It is anticipated that the construction contract period will be 90 days, time and materials budgets are based upon this assumed construction contract time.

ARTICLE 5. COMPENSATION

Compensation for this Work Release will be as follows:

Compensation Summary			
Phase	Description	(\$)	*Fee Type
1	Preliminary Engineering Services	\$4,000	Lump Sum
2	Engineering Design Services - Sewer-line Replacements	\$24,000	Lump Sum
3	Bidding Phase Services	\$9,000	**T&M
4	Construction Phase Services	\$20,000	**T&M
	TOTAL	\$57,000	
*Lump Sum=Fixed Fee; T&M=Time and Materials; NTE= Not to Exceed			
**Budgeted T&M (Time and Materials) is a budgeted amount that will not be exceeded without Client approval and does not guarantee the tasks will be completed within this amount.			

CLIENT agrees to compensate SE for the lump sum amounts listed for the lump sum items.

CLIENT agrees to compensate SE on a Time and Materials basis at the rates and fees listed in the attached Exhibit A for the T&M items listed in the compensation summary. Estimated fees listed in the compensation summary table above are budgetary estimates; actual expenses will be based on actual services requested by the CLIENT and may exceed or be less than the estimates listed.

Any additional services not listed above, that are requested by CLIENT and concurred by SE, will be performed at the rates and fees shown in the attached Exhibit A. SE will submit itemized billings, each month for this work.

ARTICLE 6. INVOICING

Instructions and invoices submitted pursuant to this Work Release shall be sent to:

DAGGETT COUNTY
PO BOX 219
MANILA, UT 84046

Invoices shall be submitted monthly based on the prior month's effort and are due and payable within (30) thirty days

Exhibit A

SUNRISE ENGINEERING

FEE SCHEDULE*

Work Classification	Hourly Rate	Work Classification	Hourly Rate
Administrative I	\$78	Electrical Project Manager II	\$215
Administrative II	\$98	Electrical Project Manager III	\$230
Administrative III	\$116	Construction Observer I	\$109
Administrative IV	\$138	Construction Observer II	\$132
Technical Editor	\$90	Construction Observer III	\$146
Funding Specialist	\$159	Construction Observer IV	\$168
Civil Engineering Intern	\$110	Construction Observer V	\$189
Civil EIT I	\$125	Project Manager I	\$171
Civil EIT II	\$139	Project Manager II	\$184
Civil EIT III	\$154	Project Manager III	\$195
Civil Engineer III	\$171	Project Manager IV	\$213
Civil Engineer IV	\$185	Project Manager V	\$244
Civil Engineer V	\$199	Plan Reviewer	\$110
Civil Engineer VI	\$214	Building Inspector III	\$96
Civil Engineer VII	\$229	Building Official	\$210
Senior Civil Engineer	\$243	GIS Tech	\$94
Principal Civil Engineer	\$256	GIS Senior Tech	\$115
Civil Engineering Tech I	\$101	GIS Analyst	\$140
Civil Engineering Tech II	\$114	GIS Senior Analyst	\$165
Civil Engineering Tech III	\$133	GIS Developer	\$182
Civil Engineering Tech IV	\$148	GIS Team Lead	\$188
Civil Engineering Tech V	\$164	Planner I	\$132
CAD Drafter I	\$102	Planner II	\$148
CAD Drafter II	\$122	Planner III	\$164
CAD/Designer III	\$136	Planner IV	\$180
CAD/Designer IV	\$151	Planner V	\$196
CAD/Designer V	\$169	Planning Manager	\$212
Electrical Engineering Intern	\$106	PI Specialist I	\$118
Electrical EIT I	\$143	PI Specialist II	\$129
Electrical EIT II	\$161	PI Specialist III	\$141
Electrical Engineer III	\$182	PI Specialist IV	\$153
Electrical Engineer IV	\$209	PI Manager	\$165
Electrical Engineer V	\$231	PI Director	\$177
Principal Electrical Engineer	\$254	Survey Tech	\$99
Electrical Engineering Tech I	\$110	Survey CAD Tech	\$145
Electrical Engineering Tech II	\$128	Survey Manager	\$196
Electrical Engineering Tech III	\$149	Registered Surveyor	\$212
Electrical Engineering Tech IV	\$165	Principal Surveyor	\$234
Electrical Engineering Tech V	\$182	One Man Survey Crew	\$172
Electrical Project Manager I	\$185		

REIMBURSABLE EXPENSE SCHEDULE*

Expense	Rate
Mileage	\$0.67/Mile
Per Diem	\$59/Day
Field Vehicle (On-Site)	\$250/Day
UTV (On-Site)	\$200/Day
Nuclear Density Gauge	\$150/Day

*Fees automatically change after the beginning of each year and are subject to change on other occasions.

*Subconsultant and other direct expenses will be invoiced as cost incurred plus 15% handling fee.

*A convenience fee of 4% will be applied to all payments made with a credit card.

SE-2026 01-2026