

**WOODS CROSS CITY
PLANNING COMMISSION AGENDA
TUESDAY, MARCH 10, 2026, AT 6:30 P.M.**



This meeting is held in person at 1555 South 800 West, Woods Cross, Utah and via Zoom.

To join using Zoom, click here <https://us02web.zoom.us/j/9358074960> or go to zoom.us and select JOIN A MEETING. Meeting ID: 935 807 4960. Please mute your microphone except during the open comment period. Questions and comments are best made in the CHAT feature.

The public is invited to participate in all Planning Commission Meetings. If you require accommodation or assistance to participate, please call the Community Development Department at 801-292-4421

1. Pledge

LeGrande Blackley

2. Meeting Minutes from February 24, 2026

Joe Rupp

- Review
- Action

3. Open Session

Joe Rupp

4. Conditional Use Permit for Tech Connect at 2272 South 1560 West

Applicant: Ben Forsyth

Presenter: Leah Seawright

- Review
- Action

5. Conditional Use Permit for American Tires at 1901 West 2425 South, Suite M

Applicant: Arif Obic

Presenter: Leah Seawright

- Review
- Action

6. Discussion: Transportation Master Plan
Presenter: Vijay Kornala & Sam Christiansen

7. Director's Report
Curtis Poole

8. Adjourn

**WOODS CROSS PLANNING COMMISSION MEETING
FEBRUARY 24, 2026**

The minutes of the Woods Cross Planning Commission meeting held February 24, 2026, at 6:30 P.M. in the Woods Cross City Hall located at 1555 South 800 West, Woods Cross, Utah.

COMMISSION MEMBERS PRESENT:

Joe Rupp, Chairman
LeGrande Blackley
Mike Doxey

Robin Goodman
Jake Hennessy-online
David Lewis IV

COMMISSION MEMBERS EXCUSED:

Mariah Wall

STAFF PRESENT:

Curtis Poole, Community Development Director
Leah Seawright, Code Officer
Bonnie Craig, Administrative Assistant

VISITORS:

Susan Delahunty
Dan Delahunty

PLEDGE OF ALLEGIANCE:

Mike Doxey

MINUTE APPROVAL

Chairman Rupp called for the review of the Planning Commission minutes for the Planning Commission meeting held February 10, 2026.

Following the review of the minutes, Commissioner Doxey made a motion to approve the minutes as written with Commissioner Goodman seconding the motion and all voted in favor of the motion through a roll call vote.

OPEN SESSION

Chairman Rupp then opened the meeting for public comments on items that were not on the agenda.

There were no public comments and Chairman Rupp closed the open session.

CONDITIOAL USE PERMIT FOR PACIFIC PAINT AND WALL COVERING AT 2391 SOUTH 1560 WEST, SUITE D—SUSAN DELAHUNTY

Ms. Seawright reviewed this item with the Commission. She noted the applicant is requesting approval of a conditional use permit for the purpose of establishing a painting contractor business in the warehouse at this location. She said this business would focus on painting and /or wall coverings for commercial

**OFFICIAL MINUTES
WOODS CROSS CITY PLANNING COMMISSION MEETING
FEBRUARY 24, 2026
PAGE 2**

construction. She also said the applicant has indicated that all business activities and storage will be maintained within the warehouse. She also said there is no anticipation for outside storage and there will be a limited number of visitors to the facility. She noted deliveries will occur during regular business hours and business hours will be from 8:00 AM-5:00 PM. She also noted there are currently 8 employees with 10 designated parking spaces available for employees and customers.

Commissioner Doxey asked if outside storage would be allowed in the fenced area in the rear of the business. Mr. Poole said a solid wall would be required for any outside storage. He said there is no wall around this particular unit so they would need to construct a wall if they desired any outside storage.

Ms. Susan Delahunty and Mr. Dan Delahunty addressed the Commission and said they had been in the area for around 20 years and are just moving their business a few buildings to the south.

Chairman Rupp asked if there were any concerns with the conditions and the Delhuntys said no they did not have any concerns with the conditions.

There were no further questions and Commissioner Goodman made a motion to approve the conditional use permit for Pacific Pain and Wall Covering with the following conditions:

1. Obtain and maintain a business license.
2. Obtain a South Davis Metro Fire inspection, if required, and submit a copy to the city prior to the issuance of a business license.
3. Business shall be in compliance at all times with any government entity having jurisdiction over the business or the subject property.
4. Business operations shall not negatively impact on the adjacent businesses and properties.

Commissioner Doxey seconded the motion, and all voted in favor of the motion through a roll call vote.

**CONDITIONAL USE PERMIT FOR AREO KRAFT AVIATION AT 2115 SOUTH 1800 WEST, SUITE 6—
MATTHEW KRAFT**

Ms. Seawright reviewed this item with the Commission. She noted the applicant, Mr. Matthew Kraft, is requesting approval of a conditional use permit for the purpose of establishing an aviation manufacturing and repair business in the hangar at this location. She noted the proposed business would focus on building custom aircraft as well as repairing damaged aircraft for insurance companies and private owners. She said the applicant has indicated that all business activities and storage will be maintained within the hangar. She also said there is no anticipation for outside storage, and it is anticipated there will be a limited number of visitors to the facility. She also noted all deliveries will occur during regular business hours. She went on to say the company currently has 1 employee with 2 designated parking spaces available for employees and customers and hours of operation will be from 9:00 AM-5:00 PM.

Following the information given by Ms. Seawright, Mr. Matthew Kraft addressed the Commission. He noted he was the owner of this business, and they are located within the Skypark Airport. He said they moved into the hangar about a year ago and started the business in January.

**OFFICIAL MINUTES
WOODS CROSS CITY PLANNING COMMISSION MEETING
FEBRUARY 24, 2026
PAGE 3**

Chairman Rupp asked Mr. Kraft if there were any concerns with the conditions that had been presented and Mr. Kraft said he did not have any concerns with the conditions.

There were no further questions and Commissioner Doxey made a motion to approve the conditional use permit for Aero Kraft Aviation with the following conditions:

1. Obtain and maintain a business license.
2. Obtain a South Davis Metro Fire inspection, if required, and submit a copy to the city prior to the issuance of a business license.
3. Business shall be in compliance at all times with any government entity having jurisdiction over the business or the subject property.
4. Business operations shall not negatively impact on the adjacent businesses and properties.

Commissioner Goodman seconded the motion, and all voted in favor of the motion through a roll call vote.

DIRECTOR'S REPORT

Mr. Poole noted Commissioner Lewis wanted to talk about conflict of interest, but he said they will hold off on that discussion until Commissioner Lewis could be present for that discussion

Mr. Poole said at the next meeting they would most likely have a discussion on the Transportation Master Plan with the Public Works Director and City Engineer. He said this will be a discussion item only.

He noted that last week the Council discussed having a member of the City Council as a liaison to the Planning Commission. He said the Council was split on whether or not they would want to continue with that tradition. Mr. Poole said the Mayor will make a decision soon on that matter.

Mr. Poole said there was a fire still smoldering that had recently started in a very large mulch pile located within the city. He said it is likely to be smoldering for days if not weeks. He said the fire department cannot just knock it down because there is not enough room on the property to do so. He said the fire department will be stepping away and are leaving it up to the property owner to maintain the continuing problem.

Mr. Poole said they are continuing to work on the plans for the new city hall and the park that is being reconstructed. He said there will be a large community room in the building, which will be a nice addition to the new building.

Mr. Poole noted there is a new city website and invited the Commission to explore the new website.

Mr. Poole noted they are contracting with a company for a new codification software to be able to make searching City Code much easier.

**OFFICIAL MINUTES
WOODS CROSS CITY PLANNING COMMISSION MEETING
FEBRUARY 24, 2026
PAGE 4**

ADJOURNMENT

There being no further business before the Planning Commission, Commissioner Goodman made a motion to adjourn the meeting at 6:48 P.M.

Joe Rupp, Chairman

Bonnie Craig, Administrative Assistant

STAFF REPORT

To: Planning Commission

From: Leah Seawright, Community Development

Date: March 10, 2026

Re: Conditional Use Request – Office/Warehouse



Location: 2272 S 1560 W

Zoning: AP (Airport) Zone

Background

The applicant, Benjamin Forsyth, is requesting approval of a conditional use permit for the purpose of establishing an office/warehouse space for Tech Connect, at this location. City Code authorizes the Planning Commission to review conditional use requests for contracting businesses and impose conditions to mitigate potential adverse impacts to surrounding property owners, such as traffic, parking, noise, etc.

Staff Review

The proposed office/warehouse business would focus on repair and maintenance for backup power equipment. The applicant has indicated that all business activities and storage will be maintained within the building. Deliveries will occur during regular business hours.

The company currently has 8 employees with 11 designated parking spaces available for employees and customers. Hours of operation are 09:00 AM-5:00 PM.

The code requires 1 parking space per 800 square feet. Based on the square footage of the unit, the business is within code requirements.

Staff does not anticipate any adverse impacts to surrounding property owners. Staff find that the use complies with City codes, is consistent with the General Plan, and is compatible with neighboring properties.

Staff Recommendation

Staff recommends the Planning Commission approve the conditional use request for an office/warehouse; Tech Connect with the following conditions:

1. Obtain and maintain a business license.
2. Obtain a South Davis Metro Fire inspection, if required, and submit a copy to the city prior to the issuance of a business license.

3. Business shall be in compliance at all times with any government entity having jurisdiction over the business or the subject property.
4. Business operations shall not negatively impact the adjacent businesses and properties.

Item: Tech Connect Conditional Use

Address: 2272 South 1560 West

Map 1
Citywide

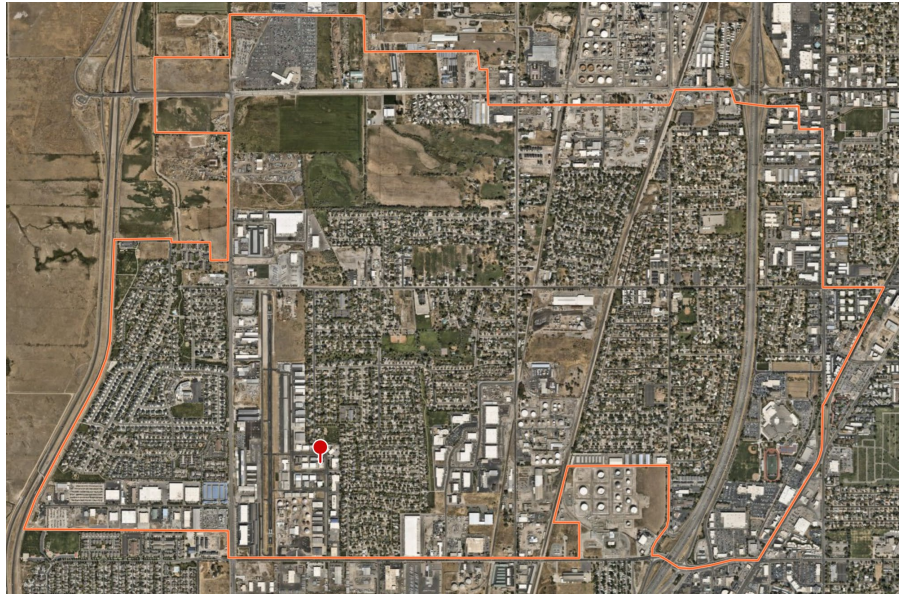

Map 2
Neighborhood

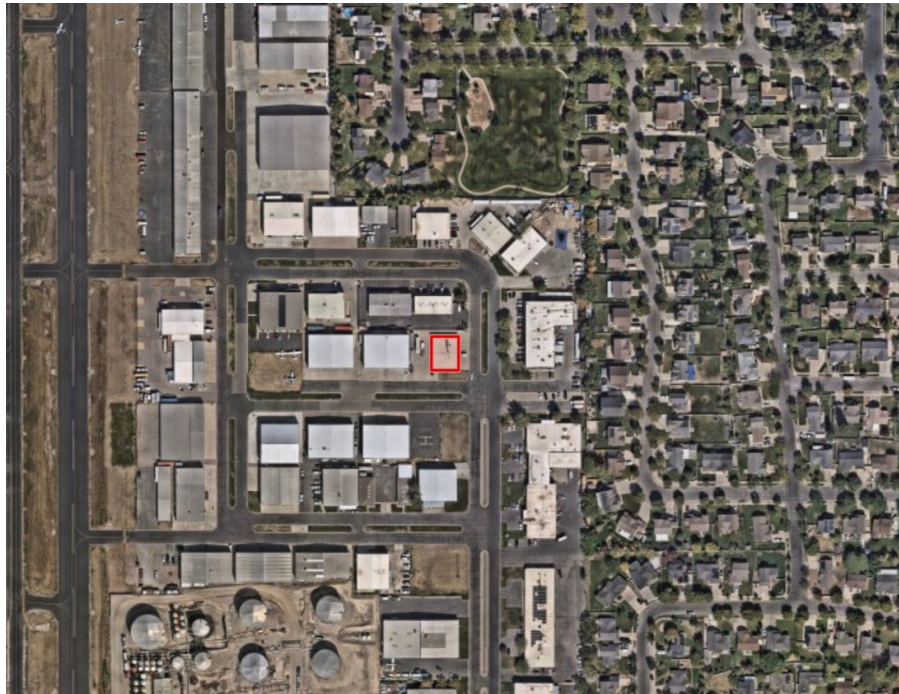

STAFF REPORT

To: Planning Commission

From: Leah Seawright, Community Development

Date: March 10, 2026

Re: Conditional Use Request – Automotive Repair Business



Location: 1901 W 2425 S, Suite M

Zoning: I-1 (Light Industrial/Business Park) Zone

Background

The applicant, Arif Obic, is requesting approval of a conditional use permit for the purpose of establishing an auto repair business, American Tires, at this location. City Code authorizes the Planning Commission to review conditional use requests for contracting businesses and impose conditions to mitigate potential adverse impacts to surrounding property owners, such as traffic, parking, noise, etc.

Staff Review

The proposed auto repair business would focus on repair and maintenance for semi tractors for FedEx. The business also provides tire services to include installation, repair and sales for the public. The applicant has indicated that all business activities and storage will be maintained within the building. There is no anticipation for outside storage. It is anticipated there will be a limited number of visitors to the facility. Deliveries will occur during regular business hours.

The company currently has 3 employees with 3 designated parking spaces available for employees and customers. Hours of operation are 08:00 AM-5:00 PM.

The code requires 1 parking space per 800 square feet. Based on the square footage of the unit, the business is within code requirements.

Staff does not anticipate any adverse impacts to surrounding property owners. Staff find that the use complies with City codes, is consistent with the General Plan, and is compatible with neighboring properties.

Staff Recommendation

Staff recommends the Planning Commission approve the conditional use request for an automotive repair business use, American Tires with the following conditions:

1. Obtain and maintain a business license.

2. Obtain a South Davis Metro Fire inspection, if required, and submit a copy to the city prior to the issuance of a business license.
3. Business shall be in compliance at all times with any government entity having jurisdiction over the business or the subject property.
4. Business operations shall not negatively impact the adjacent businesses and properties.

Item: American Tires Conditional Use

Address: 1901 West 2425 South, Suite M

Map 1
Citywide

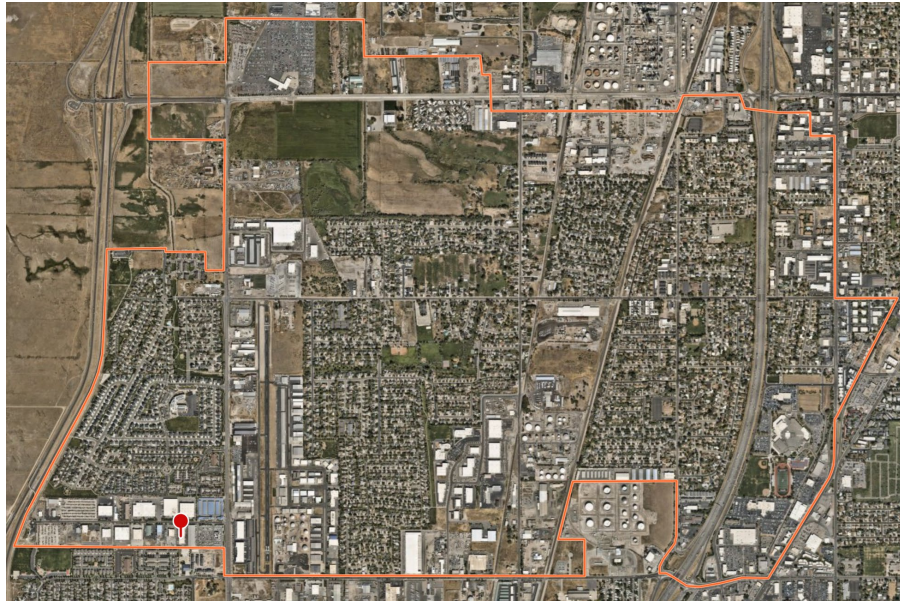

Map 2
Neighborhood

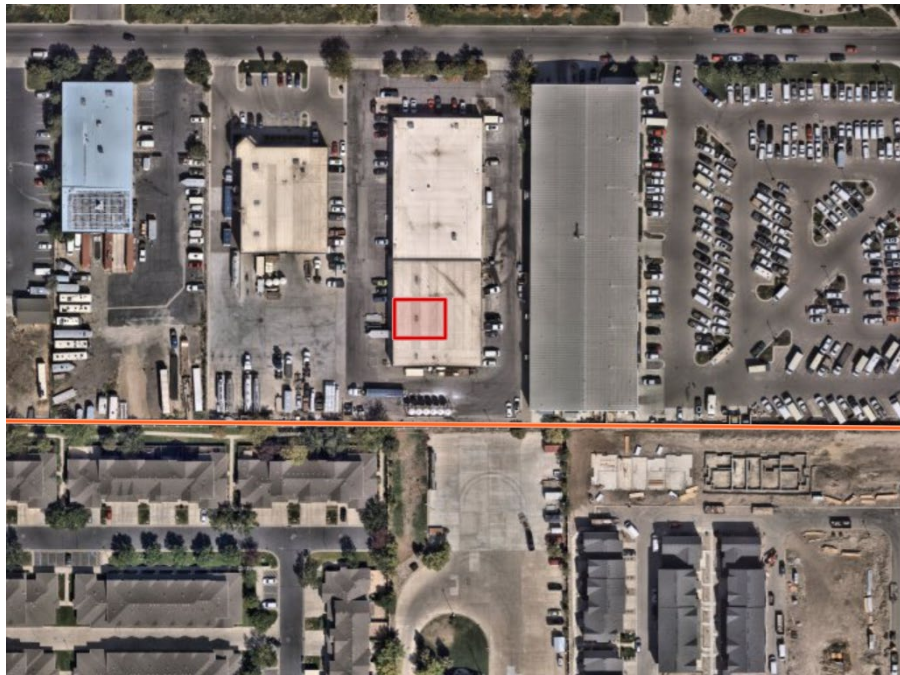

STAFF REPORT

To: Planning Commission

From: Curtis Poole, Community Development Director

Date: March 10, 2026

Re: Discussion – Transportation Master Plan



Background

The General Plan adopted in 2019 recognized the importance of proactively addressing the city's transportation system in order to accommodate both existing and anticipated future growth. At the time the plan was adopted, the city's population growth rate was estimated at approximately a 2% annual rate. As the community continues to develop and redevelop, it is important that the transportation network is evaluated to ensure that streets, intersections, pedestrian connections, and other transportation infrastructure can safely and efficiently serve residents, businesses, and visitors.

In addition to the city's local planning goals, state law requires that municipal general plans include a transportation element. This element is intended to identify existing transportation facilities, anticipate future needs, and provide guidance for improvements that will support growth and maintain mobility throughout the community. Updating and refining the city's transportation planning documents helps ensure that the city is making informed decisions regarding roadway improvements, connectivity, and long-term infrastructure investments.

To assist with this effort, the city has worked with J-U-B Engineers to prepare a Transportation Master Plan. The purpose of the plan is to evaluate the current transportation network, identify areas where improvements may be needed, and provide recommendations that will help guide transportation planning and capital improvements in the coming years.

Staff Recommendation

J-U-B Engineers has prepared a draft Transportation Master Plan for the Commission's review and consideration. The traffic engineer from J-U-B will be present at the meeting to provide an overview of the plan, discuss the methodology used in preparing the document, and highlight key recommendations. The Commission will also have an opportunity to ask questions and provide feedback.

Following this discussion and any direction provided by the Commission, J-U-B and City Staff will incorporate feedback and prepare a final version. At a future meeting, the Planning Commission will be asked to review and consider forwarding a recommendation to the City Council for its review and possible adoption.

Transportation Master Plan

City of Woods Cross



Woods Cross City

February 2026

Prepared by:



J-U-B ENGINEERS, Inc.

392 East Winchester Street, Suite 300

Salt Lake City, UT 84107

Project No. 07-24-094

Transportation Master Plan Woods Cross City



February 2026

Prepared by:



J-U-B ENGINEERS, Inc.

392 East Winchester Street, Suite 300

Salt Lake City, UT 84107

Project No. 07-24-094

TABLE OF CONTENTS

TABLE OF CONTENTS	I
TABLE OF FIGURES.....	IV
TABLE OF TABLES.....	V
1. INTRODUCTION.....	1
1.1 BACKGROUND.....	1
1.2 PURPOSE OF THE TRANSPORTATION MASTER PLAN.....	1
1.3 PLAN DEVELOPMENT PROCESS.....	2
1.4 STUDY AREA.....	2
2. EXISTING CONDITIONS.....	4
2.1 LAND USE.....	4
2.2 EXISTING ROADWAY FUNCTIONAL CLASSIFICATION.....	4
2.3 INTERSECTION CONTROL.....	6
2.4 TRAFFIC COUNTS.....	8
2.5 LEVEL OF SERVICE.....	8
2.6 EXISTING CONDITIONS TRAFFIC ANALYSIS.....	8
2.7 CRASH HISTORY.....	11
2.8 ALTERNATIVE TRAVEL MODES.....	14
2.9 TRUCK ROUTES AND RESTRICTIONS.....	15
3. FUTURE CONDITIONS.....	17
3.1 FUTURE LAND USE.....	17
3.2 TRAFFIC FORECASTS.....	18
3.3 AREAS OF CONCERN.....	19
3.3.1 Central & Industrial Area.....	19
3.3.2 1500 South Corridor.....	19
3.3.3 North-South Corridors.....	20
3.3.4 East-West Corridors.....	20
3.3.5 FrontRunner Station Access Corridors.....	20
3.4 2050 TRAFFIC ANALYSIS.....	21

WOODS CROSS TRANSPORTATION MASTER PLAN

3.4.1 2050 No-Build 21

3.4.2 2050 Build 22

4. ACTIVE TRANSPORTATION 24

4.1 VISION AND GOALS..... 24

4.2 EXISTING CONDITIONS..... 24

4.3 RECOMMENDATIONS 27

4.3.1 Projects..... 27

4.3.2 Programs 30

4.3.3 Policies..... 30

4.4 IMPLEMENTATION STRATEGY 31

4.4.1 Prioritized list of actions or recommendations..... 31

4.4.2 Capital and Maintenance Costs & Budgets..... 32

4.4.3 Funding Opportunities..... 32

4.5 PERFORMANCE MEASURES 32

5. RECOMMENDATIONS 33

5.1 ROADWAY AND INTERSECTION CONTROL..... 33

5.2 STREET STANDARDS 34

5.3 ACCESS MANAGEMENT 37

5.4 ROADWAY LIGHTING 38

5.5 TRANSIT 38

6. CAPITAL IMPROVEMENT PLAN..... 40

6.1 CAPITAL IMPROVEMENT PLAN 40

6.2 WOODS CROSS CONNECTIVITY PLAN (MANDATED BY SENATE BILL 195)..... 44

7. TRAFFIC CALMING..... 49

7.1 TRAFFIC CALMING..... 49

7.1.1 Installing Traffic Calming Measures 49

8. TRAFFIC IMPACT STUDY GUIDELINES..... 49

8.1 TRAFFIC IMPACT STUDIES 49

APPENDIX A: TRAFFIC COUNTS AND ANALYSIS 50

APPENDIX B: CRASH ANALYSIS RESULTS..... 51

APPENDIX C: TRAFFIC ANALYSIS ZONE INPUTS..... 52

WOODS CROSS TRANSPORTATION MASTER PLAN

APPENDIX D: ARTERIAL AND COLLECTOR TYPICAL SECTIONS 53
APPENDIX E: COMMUNITY ENGAGEMENT 54
APPENDIX F: PROJECT COST ESTIMATES 55
APPENDIX G: TRAFFIC IMPACT STUDY GUIDELINES 56

DRAFT

TABLE OF FIGURES

Figure 1: Existing Zoning Map	3
Figure 2: Existing Functional Classification & Number of Lanes.....	7
Figure 3: Existing AADT and Level of Service	10
Figure 4: Year 2050 No-Build Daily Traffic Volumes and Level of Service.....	23
Figure 5: Active Transportation – Existing Map.....	26
Figure 6: Future Active Transportation Projects	28
Figure 7: Bike Lane Option on Existing Street.....	29
Figure 8: 2050 Functional Classification and Intersection Control	35
Figure 9: 2050 AADT/LOS	36
Figure 10: Capital Improvement Plan	41
Figure 11: SB-195 Projects.....	48

DRAFT

TABLE OF TABLES

Table 1: Roadway Functional Classifications.....	5
Table 2: Intersection Crashes (2020-2025)	12
Table 3: Segment Crashes (2020-2025).....	13
Table 4: Railroad Crashes	14
Table 5: Model Socio-economic Inputs*	18
Table 6: Daily Service Volumes and Assumptions*	19
Table 7: AT Project List.....	31
Table 8: Summary of Typical Roadway Cross Sections.....	34
Table 9: Additional Access Management Criteria for Regional Corridors	38
Table 10: Transportation Improvement Projects 0-5 Years.....	42
Table 11: Transportation Improvement Projects 5+ Years.....	42

DRAFT

1. INTRODUCTION

1.1 BACKGROUND

The Woods Cross City Transportation Master Plan (TMP) contains the goals, objectives and policy guidance as well as an overview of the strategies that the City intends to accomplish by the year 2050. The TMP is the City's long-range blueprint for travel and mobility. The City's General Plan, most recently updated in 2022, recognized the need to address existing and future growth in a manner that maintains convenient mobility and access for residents while preserving the urban lifestyle that is important to the well-being of the community, both culturally and socially.

Since the adoption of the General Plan, it has become necessary to prepare a comprehensive TMP due to on-going development and other changes throughout the City. The City has seen continued population growth and is expected to continue to grow with an efficient and functional system of streets that Woods Cross offers.

1.2 PURPOSE OF THE TRANSPORTATION MASTER PLAN

The Woods Cross City TMP serves a variety of purposes and is a vision that defines the City's long-term transportation needs into the future. The TMP also provides policy direction on decisions regarding the implementation of the transportation system projects. It also serves as a comprehensive reference guide for major transportation system issues in Woods Cross City. Finally, the TMP prioritizes projects for implementation to address short-term deficiencies and safety for motorized and non-motorized travel, while working towards the ultimate transportation system needs of the city by the year 2050.

As a result of the City's continued growth, there has been a steady increase in vehicle trip volumes, and an increase in traffic across the existing street network. The city remains committed to providing a balanced transportation system that provides citizens with transportation choices to maintain its high quality of life. This TMP update provides the goals, principles, and policies that will be used to change the transportation system today and shape it for the future. These guidelines and policies will aid City staff and officials in making informed decisions regarding transportation policies. The Capital Improvements Plan (CIP) identifies near-term projects to improve deficiencies in the existing transportation system. Additionally, the CIP looks forward to year 2050 to create a comprehensive list of projects that require significant advance planning and funding resources to implement but are needed to accommodate the future transportation demands.

1.3 PLAN DEVELOPMENT PROCESS

This TMP update was administered by Woods Cross City as part of the General Plan Update. This TMP update was completed with the collaboration and guidance of City staff and UDOT during the update process and shows baseline data reflecting existing (2024) conditions. Two open houses were conducted, one to gather feedback from the public prior to initiating the TMP and a second open house was held after the recommended Projects list was developed for public input.

1.4 STUDY AREA

The study area for the Woods Cross Transportation Master Plan encompasses the full municipal boundary of Woods Cross City, capturing its diverse land uses, transportation corridors, and regional connections. As shown in **Figure 1**, the study area includes a mix of residential neighborhoods, commercial districts, industrial zones, and special-use areas that collectively shape travel patterns and infrastructure needs throughout the community.

DRAFT

Figure 1: Existing Zoning Map

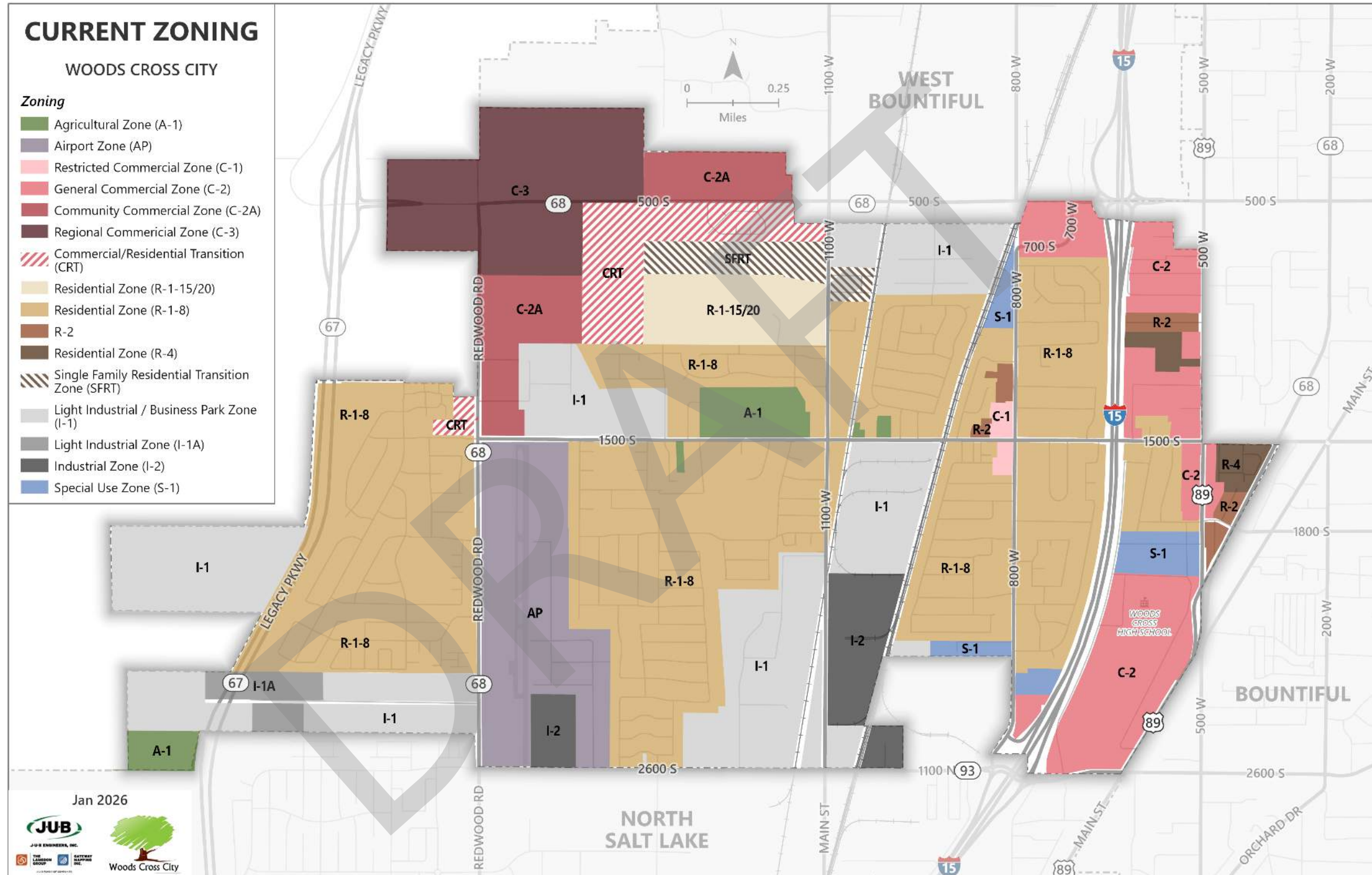

2. EXISTING CONDITIONS

Developing an accurate assessment of the existing conditions in the City is an important first step in developing a TMP. As a part of this process, an inventory along with an evaluation of existing conditions within the study area was completed to identify existing transportation issues and to establish a framework for the analysis of future conditions. The existing street network and traffic patterns will serve as the basis for the future street network and for identifying future transportation conditions and needs.

The first public open house was conducted on November 20, 2024 to solicit public input for the initiation of the TMP. Comments were received and incorporated into the data gathering and overall TMP development.

2.1 LAND USE

In 2020, at the time of the last US Census, the population of Woods Cross City was found to be 11,410 residents . By 2024 the City has an estimated population of nearly 11,493. This growth represents approximately a 0.73% increase in population between 2020 and 2024. Woods Cross City has the potential for significantly more growth as the northwest quadrant of the City develops into the future.

Woods Cross City's future land use pattern reflects a balanced mix of residential neighborhoods, commercial corridors, and industrial employment areas that guide how the community will grow over time. As shown in **Figure 2**, commercial activity is concentrated along 500 West (US-89), Redwood Road (SR-68) and 500 South (SR-68), forming the City's primary activity centers and supporting local and regional travel demand. Established single-family neighborhoods surround these corridors, while additional residential areas are planned within the City's designated annexation boundary. South-central portions of the City contain significant industrial uses, including refinery and storage facilities located between two active railroad corridors, which play a major role in shaping traffic patterns and freight movement. Several undeveloped parcels, particularly in the north western portion of the City along with approximately 151 acres of future annexation area, are anticipated to transition to Community Commercial, Regional Commercial, and residential uses as identified in the 2022 General Plan Update. As these areas develop, additional trips will be generated, resulting in increased demand on the roadway network and emphasizing the importance of long-range transportation planning.

2.2 EXISTING ROADWAY FUNCTIONAL CLASSIFICATION

The existing roadways are classified by function according to guidelines prepared by the Federal Highway Administration (FHWA). Federal funding programs specifically apply to roadways with

WOODS CROSS TRANSPORTATION MASTER PLAN

functional classifications of collectors and above. Roadways are classified based on their function, with respect to both mobility and access. For example, an interstate freeway occupies one end of a continuum between mobility and access, providing traffic with greater mobility and little access to adjacent lands. A cul-de-sac, at the opposite end of this continuum, provides access to land, but offers minimal movement of traffic.

To enable streets and highways to accomplish their intended function, the planning and design of the facilities should consider those elements that support the intended functions.

Descriptions of the various roadway functional types and related planning and design considerations are provided in **Table 1**. Federal funding programs only apply to roadways with functional classifications of collectors and above.

Table 1: Roadway Functional Classifications

Roadway Classification	Description	Example
Interstate	Interstates promote movement of traffic with limited access, high speeds, separated directional lanes, adequate geometries, and grade-separated intersections. The interstate freeway is essentially a specialized Major Arterial.	I-15 I-80 I-84
Major Arterial	Principal Arterials are generally the high traffic volume roads within a study area. These roadways contain the greatest proportion of through or long-distance travel. Roadway access should be limited to promote efficient traffic movement. Speeds are generally in the 35 to 45 mph range in urban situations, and parking is usually prohibited. Arterials are typically about a mile apart but may be spaced with a half-mile separation. Many of the intersections will be signalized, and signal placement and coordination are critical to the operation of the arterial.	SR-68, US-89, SR-108, SR-126
Minor Arterial	Roadways that connect principal arterials and collectors are classified as minor arterials. Minor arterials usually have capacity sufficient to carry 3 or 4 lanes of traffic and have curb, gutter, and sidewalk along both sides. The predominant function of a minor arterial is to promote movement of through traffic, but these facilities also provide considerable access for local traffic that originate or is destined to points along the roadway. Often minor arterials become boundaries to neighborhoods and serve less concentrated developments such as neighborhood shopping centers or schools. Urban speeds are generally in the 35 to 40 mph range. Access may be restricted, and parking is often prohibited in an urban situation.	SR-37 (4000 South) SR-97 (5500 South)
Collector	A collector is intended to assemble and concentrate residential and rural traffic and direct it to the arterial system. Collectors usually are designed with 2 or 3 lanes of traffic, and have curb, gutter, and sidewalk along both sides. Direct access to adjoining property is common and often essential. Operating speeds are generally in the 25 to 35 mph range. Parking is acceptable but may be limited. Collectors are sometimes sub-categorized into major and minor collectors. Major collectors tend to connect important regional facilities directly to the arterials, while minor collectors usually connect to the local roads.	5500 West, 5100 South

Roadway Classification	Description	Example
Local Streets	Local streets typically consist of two lanes with shoulders, with curb, gutter and sidewalks present in some locations. Local roads are the capillaries of a transportation network, providing direct access to public facilities, businesses, and private property. The typical speed limit on local streets is 20 to 25 mph and parking is usually permitted.	Local streets constitute all the City-owned roads that are not classified under the preceding categories. Some local roads may also be private streets.

Figure 2 shows the existing functional classification for Woods Cross City. Several roadway segments, particularly older collector streets do not meet current City standards and lack adequate pavement width or pedestrian infrastructure. Current City policy now requires all new development and roadway projects to construct curb, gutter, and sidewalks consistent with adopted street standards.

2.3 INTERSECTION CONTROL

Traffic control devices are an essential element at each intersection because they regulate traffic flow and can improve safety. Intersection control devices include roundabouts, stop signs (2-way and 4-way), traffic signals, and yield signs. Within Wood Cross, there is one existing signalized intersection located at the intersection of 800 West / 1500 South and one existing roundabout at Mountain View Blvd. / 1500 South. As traffic congestion increases, the need to modify major intersections with traffic signals and roundabouts can be expected.

Figure 2: Existing Functional Classification & Number of Lanes

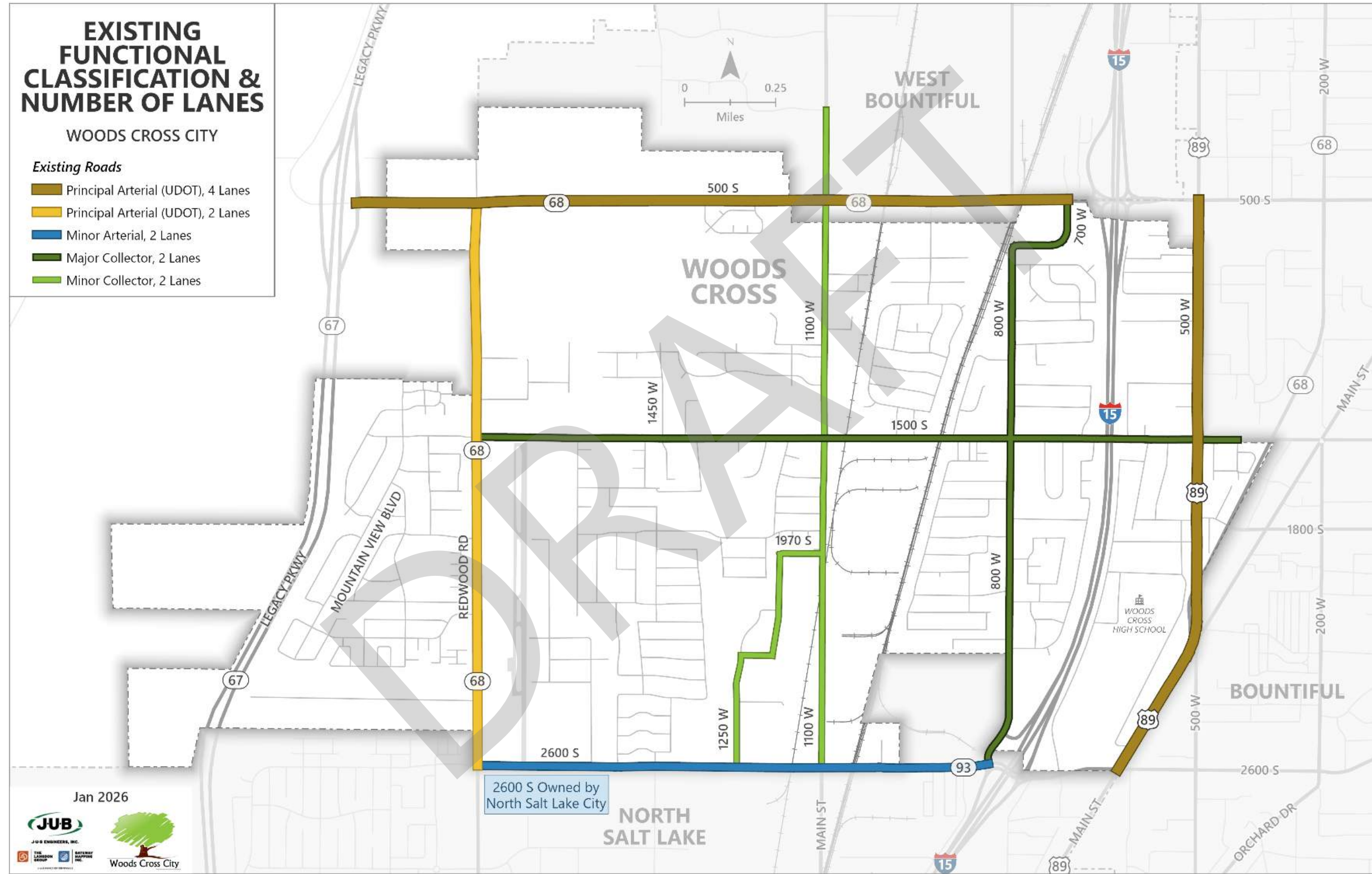

2.4 TRAFFIC COUNTS

Turning movement counts (TMC) for the AM and PM peak hours were collected using automatic traffic counters at a total of eleven locations throughout the City. Ten of the counts were collected by Quality Counts during the fall of 2024, and one location was collected by L2 Data Collection during the fall of 2022. These counts were conducted at the following locations and dates:

- 800 West / 1100 South (September 18, 2024)
- Mountain View Blvd / 1500 South (September 18, 2024)
- 1600 West / 1500 South (September 18, 2024)
- 1450 West / 1500 South (September 18, 2024)
- 1100 West / 1500 South (September 18, 2024)
- 1955 West / 1950 South (September 18, 2024)
- 1425 West / 1900 South (September 18, 2024)
- 625 West / 1950 South (September 18, 2024)
- Mountain View Blvd / 2260 South (September 18, 2024)
- 1100 West / 1970 South (September 10 and 12, 2024)
- 800 West / 1500 South (November 8, 2022)

The traffic count data is provided in **APPENDIX A: TRAFFIC COUNTS AND ANALYSIS**.

2.5 LEVEL OF SERVICE

Level of Service (LOS) is a qualitative description of the level of congestion ranging from LOS A to LOS F. LOS A through D represents free-flowing traffic and LOS E & F represents gridlock. LOS D is considered the minimum acceptable Level of Service.

2.6 EXISTING CONDITIONS TRAFFIC ANALYSIS

The 11 intersections listed in section **2.4 TRAFFIC COUNTS** were analyzed during the AM and PM peak hour using the Synchro 12. The existing conditions scenario reflects the existing lane configuration and the traffic volume for the day the traffic count data were collected. All intersection approaches operate at LOS D or better, except for the westbound approach at 1100 West / 1500 South, which operates at LOS E. Unsignalized intersections report approach LOS only and not overall intersection LOS. For a summary of LOS results, see **APPENDIX A: TRAFFIC COUNTS AND ANALYSIS**.

Under existing conditions, all arterial and collector roadway segments in Woods Cross operate at LOS D or better, indicating that current daily traffic volumes remain within acceptable planning-level thresholds. The only exception is a short segment along 2600 South, which operates at LOSE/F. This segment reflects higher traffic demand along a corridor shared with

WOODS CROSS TRANSPORTATION MASTER PLAN

North Salt Lake, and any future improvements along 2600 South will require coordination between both cities to ensure consistent and safe operations. **Figure 4** summarizes the existing daily traffic volumes and LOS results for each existing functionally classified road within the City.

DRAFT

Figure 3: Existing AADT and Level of Service

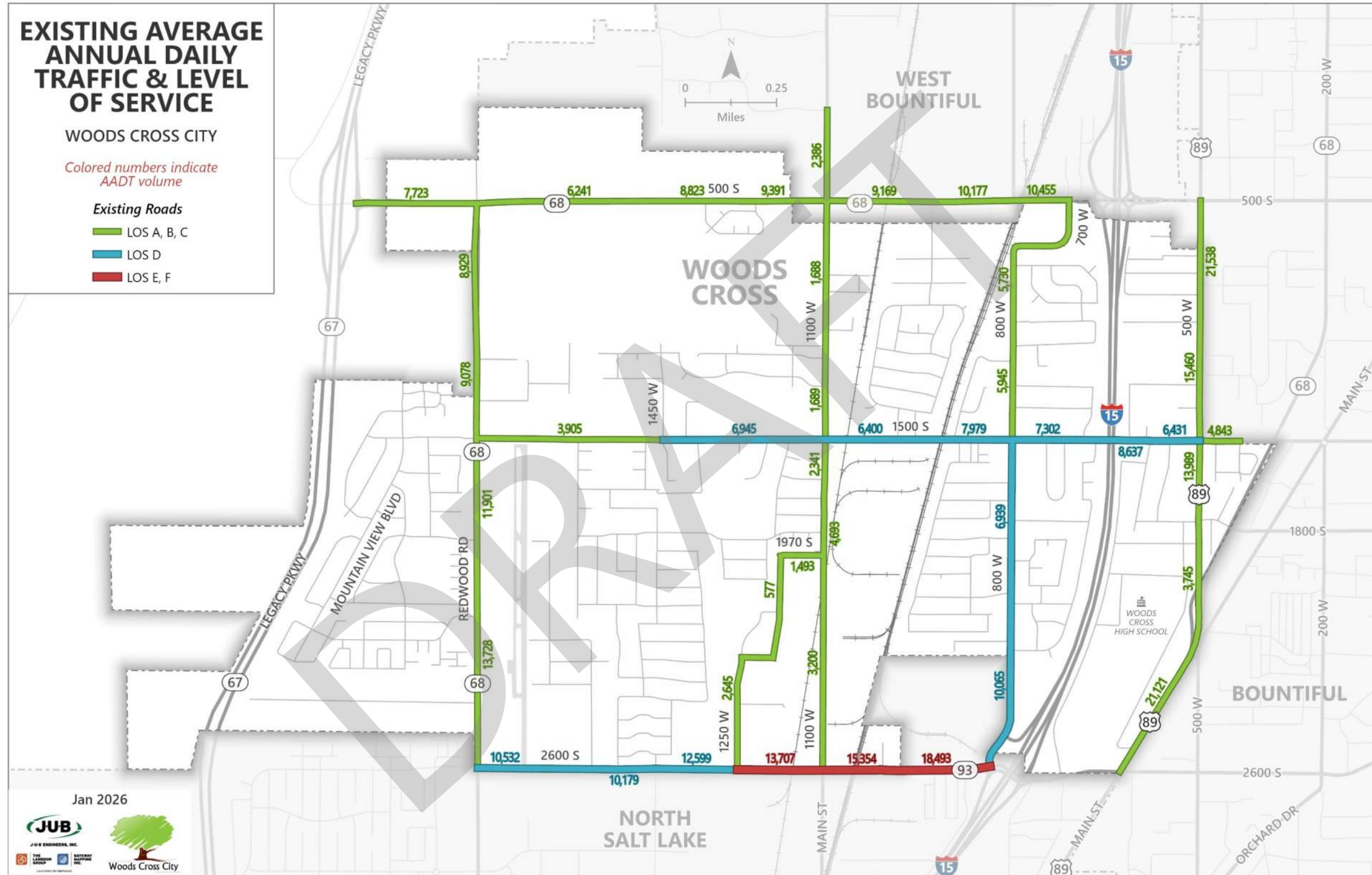

2.7 CRASH HISTORY

Crash data from October 2020 through October 2025 were collected for intersections, roadway segments, and railroad crossings using UDOT's Numetric system. The analysis focused on identifying crash patterns, contributing factors, and high-crash locations within Woods Cross City.

Table 2 summarizes crashes at key intersections with their severity. Crash analysis identified two primary hotspots along the 1500 South corridor: 1500 South / 800 West and 1500 South / 1100 West, which recorded the highest crash frequencies between 2020 and 2025.

At 1500 South / 800 West, 11 crashes occurred, including 3 front-to-rear, 3 angle, 3 single-vehicle, and 2 sideswipe-opposite-direction collisions. Commercial vehicles were involved in over one-third of crashes, and 18% occurred at night. Installation of a traffic signal in August 2024 reduced reported crashes from 9 (pre-signal) to 2 (post-signal), indicating a strong early safety benefit.

At 1500 South / 1100 West, 9 crashes were documented, dominated by front-to-rear (44%), angle (33%), and sideswipe-same-direction (22%) collisions. These patterns reflect congestion-related and turning-movement conflicts typical of two-way stop-controlled intersections.

These hotspot findings highlight the need for targeted safety strategies along the corridor. Additional long-term recommendations and operational improvements are presented in **Chapter 3. FUTURE CONDITIONS.**

Table 2: Intersection Crashes (2020-2025)

Crash Severity (Intersections)	Fatal	Suspected Serious Injury	Suspected Minor Injury	Possible Injury	No injury/PDO	Grand Total
1500S / 800W	0	0	1	3	7	11
1500S / 1100W	0	0	0	2	7	9
1900S / 1425W	0	0	1	0	1	2
1100S / 800W	0	0	0	0	1	1
1500S / MountainView	0	0	0	0	1	1
1500S / 1600W	0	0	0	1	0	1
1950S / 1955W	0	0	0	0	1	1
1970S / 1100W	0	0	1	0	0	1
1500S / 1450W	0	0	0	0	0	0
1950S / 625W	0	0	0	0	0	0
2260S / MountainView	0	0	0	0	0	0

Table 3 summarizes crashes by roadway segment and severity. Crash analysis also identified several corridor-level hotspots on key roadway segments in Woods Cross.

Along 800 West (500 South–1100 South), 10 crashes occurred, with 50% left-turn, 40% nighttime, and 30% road-departure crashes. Collision patterns were dominated by single-vehicle (40%), with angle and sideswipe crashes each representing 20%.

On 1500 South (800 West–US-89), a total of 11 crashes were reported. Of these, 27% involved disregard of traffic control, another 27% were related to road departure, and 18% involved left-turn movements. Nearly half of the crashes (46%) were single-vehicle incidents, while 27% were front-to-rear.

Two segments on 1100 West, from 1500 South to 1970 South and from 1970 South to 2600 South, each had five crashes. The northern segment (from 1500 South to 1970 South) showed high rates of nighttime (60%), DUI (40%), and single-vehicle (60%) crashes, while the southern segment (1970 South to 2600 South) was dominated by road-departure (40%), nighttime (40%), and single-vehicle (80%) crashes. An ongoing design project is underway for this segment to incorporate city-standard curbs, gutters, sidewalks, and driveways to improve area safety.

Additionally, the WFRC comprehensive safety action plan adopted in 2024 highlighted three hotspot roadway segments in Woods Cross City: Redwood Road from 500 South to 1100 North, 1100 West from 1500 South to 2600 South, and 500 West from 500 South to Main Street. These patterns highlight recurring issues related to visibility, impairment, speed management, and roadway departures. Additional corridor-level recommendations are provided in **Chapter 3.**

FUTURE CONDITIONS.

WOODS CROSS TRANSPORTATION MASTER PLAN

Table 3: Segment Crashes (2020-2025)

Crash Severity (Segments)	Fatal	Suspected Serious Injury	Suspected Minor Injury	Possible Injury	No injury/PDO	Grand Total
1500S/800W to 1500S/US-89	0	0	1	0	10	11
800W/500S to 800W/1100S	0	0	1	2	7	10
800W/1500S to 800W/2250S	0	0	2	1	2	5
1100W/1500S to 1100W/1970S	0	0	4	0	1	5
1100W/1970S to 1100W/2600S	0	0	1	1	3	5
1500S/MountainView to 1500S/1600W	0	1	1	1	0	3
1500S/MainLine to 1500S/800W	0	0	0	0	3	3
1100W/500S to 1100W/1500S	0	0	0	0	2	2
1500S/SpurLine to 1500S/MainLine	0	0	0	0	2	2
800W/1100S to 800W/1500S	0	0	0	0	1	1
1500S/2095W to 1500S/MountainView	0	0	0	0	0	0
1500S/1600W to 1500S/1450W	0	0	0	0	0	0
1500S/1450W to 1500S/1100W	0	0	0	0	0	0
1500S/1100W to 1500S/SpurLine	0	0	0	0	0	0

Table 4 summarizes crashes at railroad crossings by severity. Crash analysis also identified several railroad-related hotspots where roadway and rail operations intersect.

The Main Line / 500 South crossing experienced the highest number of railroad-related crashes, with 14 total, including 29% nighttime and 21% road-departure crashes. Collision types included front-to-rear (43%) and single vehicle (43%) crashes, reflecting queuing, sight-distance limitations, and driver-expectancy challenges common at high-volume arterial crossings.

The Main Line / 1500 South crossing experienced 4 crashes. Of these, 25% were speed-related and all (100%) were front-to-rear collisions, indicating congestion-related queuing issues near the rail crossing.

The Spur Line / 1500 South crossing experienced 1 crash, which occurred at night and involved a front-to-rear collision. The Spur Line / 1100 West crossing also experienced 1 crash, occurring at night and classified as a single-vehicle/not-applicable manner of collision.

The Main Line / 2600 South crossing recorded 6 crashes, 67% of which were front to rear crashes and 33% were sideswipe same direction crashes.

The Spur Line / 2600 South crossing experienced 3 crashes, with front-to-rear collisions (33%), single vehicle (33%) and sideswipe same direction (33%).

WOODS CROSS TRANSPORTATION MASTER PLAN

These railroad hotspots highlight the need for improved delineation, visibility, and operational treatments. Additional countermeasures and corridor-level recommendations are presented in **Chapter 3. FUTURE CONDITIONS.**

Table 4: Railroad Crashes

Crash Severity (Rail Road)	Fatal	Suspected Serious Injury	Suspected Minor Injury	Possible Injury	No injury/PDO	Grand Total
Main Line / 500S	0	2	1	0	11	14
Spur Line / 500S	0	0	0	2	4	6
Main Line / 1500S	0	0	1	0	3	4
Spur Line / 1500S	0	0	0	2	1	3
Spur Line / 1100W	0	0	0	0	1	1
Main Line / 2600S	0	0	1	0	0	1
Spur Line / 2600S	0	0	0	0	0	0

Detailed crash statistics for intersections, roadway segments, and railroad crossings are provided in the **APPENDIX B: CRASH ANALYSIS RESULTS.** The analysis of crash frequency, severity, manner of collision, and crash types helps identify critical safety issues and locations of concern within the study area. These findings support the development of targeted safety measures and operational improvements. This TMP integrates traffic operations analysis, crash analysis, and active transportation considerations to support the safe and efficient functioning of the transportation system. More information can be found in the following chapters.

2.8 ALTERNATIVE TRAVEL MODES

Bicycling and walking are often the only modes available to the young and elderly. Robust pedestrian and bicycle networks allow shorter distance trips to be moved from the street to bicycle or pedestrian specific facilities. In addition to providing modal options for shorter distance trips, bicycle and pedestrian facilities offer a wide range of recreational opportunities that often enhance quality of life for residents.

The City has worked to develop and build sidewalks as well as trails in area that were missing these amenities. Additionally, the City recently updated their Parks & Trails Master Plan to provide for affordable recreational, physical, and cultural opportunities for residents. More detail on these topics is provided in **Chapter 4. ACTIVE TRANSPORTATION.**

Transit service in Woods Cross is provided by the Utah Transit Authority (UTA), offering important regional connections that complement the City's roadway and active transportation networks. The Woods Cross FrontRunner Station serves as a key regional commuter rail stop,

linking residents to Ogden, Salt Lake City, and Provo with weekday and Saturday service. This station is a significant mobility asset for the community and is highlighted in the General Plan as a focus area for improved multimodal access and transit-supportive development.

Local and regional transit service supports mobility within Woods Cross. UTA Route 417 provides weekday service between Redwood Road, local neighborhoods, and the Woods Cross FrontRunner Station, offering convenient connections to regional rail. Additional regional routes along I-15, including Routes 472 and 473, provide limited peak-period service to Ogden and Salt Lake City. UTA On-Demand Zone 561 also serves the area, offering flexible local trips that improve access to nearby destinations.

Together, these transit services form a multimodal foundation that supports Woods Cross City's long-term vision of expanding transportation choices, reducing dependence on single-occupant vehicle travel, and enhancing access to regional destinations. Continued coordination with UTA will be essential for improving service levels, strengthening connections to the FrontRunner Station, and supporting future growth within key corridor and station-area planning districts.

2.9 TRUCK ROUTES AND RESTRICTIONS

Truck activity plays a significant role in Woods Cross due to the City's concentration of heavy and light industrial land uses, particularly petroleum refining, storage facilities, and rail-served industries located in the south-central portion of the community. The purpose of establishing truck routes is to guide heavy-vehicle travel onto roadway corridors that can safely and efficiently accommodate truck movements while reducing impacts to residential areas, minimizing pavement deterioration, and supporting safe multimodal operations.

Woods Cross City Municipal Code designates official truck routes within the City. Chapter 14-18-190 (Restricted Loads) outlines rules that limit or ban vehicles with loads or weights above specified limits from using certain public streets, unless necessary for local access, deliveries, or approved activities. These rules aim to protect roads and improve safety on streets not designed for heavy or oversized vehicles. Streets affected by these restrictions are established by ordinance and marked with regulatory signs.

Chapter 14-18-240 (Truck Routes) defines which roads trucks are allowed to use in Woods Cross City. The goal is to direct trucks onto arterial and major collector roads that can safely accommodate heavy vehicles, while minimizing their impact on residential areas and smaller streets. These routes and restrictions are legally enforced and updated as road conditions and land use change.

For example, 1450 West between 1200 South and 1500 South is not intended to accommodate truck traffic, and trucks should not use this segment for through-movement or local access, due to adjacent residential development, limited pavement width, and safety considerations. Most of 800 West from 500 South to 2600 South is restricted, except for 700 West from its intersection

WOODS CROSS TRANSPORTATION MASTER PLAN

with 500 South down to 700 South. On 1100 West, the segment south from 500 South to 609 South and from 1500 South to 2600 South is designated as a truck route, while all other parts of 1100 West are restricted. Further details can be found in the Truck Restriction Map in Title 14, Chapter 14-18, page 18 of the Municipal Code.

As the City grows, particularly in the Northwest Quadrant and areas near Redwood Road, continued coordination will be needed to plan and preserve appropriate freight access while protecting residential neighborhoods. To accommodate freight access appropriately, Woods Cross designated preferred truck routes in the **Woods Cross City Municipal Code Chapter 14-18-240** (along with a Truck Restriction Map) to support industrial access, manage conflicts, and extend pavement life on City streets.

DRAFT

3. FUTURE CONDITIONS

The transportation master plan reflects current and future transportation needs within the City. Future travel demand is an essential part of transportation planning by helping identify transportation needs that may not be apparent with existing demand. For this update, future traffic volumes were estimated using. WFRC maintains a CUBE model for the urbanized area within Davis County and the travel demand model was chosen as the primary tool to determine the future traffic demand within the City.

This section summarizes the population, employment, and land use assumptions. This information was utilized in the travel demand modeling process and to generate traffic forecasts volumes for functionally classified roadways within the City. These traffic forecasts were used to identify future deficiencies in the transportation system.

3.1 FUTURE LAND USE

Historically, Woods Cross City has been a predominantly residential community composed largely of established single-family neighborhoods, with additional areas dedicated to commercial and industrial uses. According to the Woods Cross City General Plan (**Chapter 2, Future Land Use, page 2-14**), the City's future land use pattern continues to emphasize stable residential neighborhoods while supporting strategic commercial and mixed-use growth along key corridors such as 500 South, Redwood Road, and 500 West. Industrial uses, including the refinery and rail-served facilities, remain essential components of the city's economic base and long-term land use structure.

The plan identifies several undeveloped or underutilized parcels, particularly on the west side near the Legacy Nature Preserve and within the 151-acre annexation area. These locations are expected to accommodate long-term growth through a mix of new residential neighborhoods, community and regional commercial uses, and future mixed-use development. Additional emphasis is placed on the 500 South/Legacy Parkway interchange and the FrontRunner Station area, where coordinated planning is intended to support economic development, improved multimodal access, and additional local services for residents.

The relationship between land uses is an important component in developing traffic forecasts. Land use influences the number of trips generated, the direction those trips travel, the travel modes selected, and the timing of travel throughout the day. Because much of Woods Cross will remain residential, a large percentage of work-related trips are expected to continue traveling to employment centers outside the city. However, planned commercial and mixed-use development may increase internal trip capture and reduce the need for longer regional trips.

Table 5 summarizes the model socio-economic inputs that were used for the Woods Cross Transportation Master Plan update. Based on the TAZ data, the population within the City's boundaries is expected to increase from 12,826 in 2023 to 22,958 by 2050, an increase of

approximately 76%. It should be noted that population values based on TAZs may be higher than those reported by the U.S. Census, since they are derived from different sources. TAZ boundaries, as used in the WFRC travel demand model, can sometimes extend into adjacent cities or include areas outside the official city limits, and may also reflect long-term land use projections not captured in current census estimates. Model socio-economics at the traffic analysis zone (TAZ) level are provided in **APPENDIX C: TRAFFIC ANALYSIS ZONE INPUTS**.

Table 5: Model Socio-economic Inputs*

Population		Households		Employment	
2023	2050	2023	2050	2023	2050
12,826	22,958	4,087	8,646	8,250	10,086

*TAZ value includes areas that extend into adjacent cities.

3.2 TRAFFIC FORECASTS

Future travel demand is an essential part of transportation planning. Travel forecasts are used to identify transportation needs that may not be apparent with existing demand. For this TMP update, future traffic conditions are based upon modeling completed with the WFRC regional travel demand model version 9.1.0 for the base year 2023 and future year 2050. The year 2050 model includes the land use assumptions summarized in **Section 3.1 FUTURE LAND USE**.

For roadways, level of service (LOS) is typically evaluated for segments of roadway without intersecting crossroads or major driveways. Segment LOS reflects the combination of travel time delay due to the signal control and the speed traveled below the free-flow speed on each roadway segment. For ease of this analysis, daily service volumes were developed for each roadway functional classification. These service volumes are used for conceptual planning and preliminary engineering purposes and are consistent with HCM methodologies. **Table 6** summarizes the daily service volumes used to evaluate the planned roadway network, as well as the assumptions used in developing these volumes.

Table 6: Daily Service Volumes and Assumptions*

Functional Class	Area Type	Posted Speed	Travel Lanes	Median	Left-turn Lane	Right-turn Lane	Daily Service Volume	
							LOS C	LOS D
Principal Arterial - UDOT 6 Lane	Transitioning	40 mph or higher	6	Divided	Yes	Yes	54,700	56,200
Principal Arterial - UDOT 4 Lane	Transitioning	40 mph or higher	4	Divided	Yes	Yes	35,700	37,300
Minor Arterial	Transitioning	35 mph or lower	2	Divided	Yes	Yes	6,500	13,300
Major Collector	Transitioning	35 mph or lower	2	Divided	Yes	No	6,200	12,600
Minor Collector	Transitioning	35 mph or lower	2	Undivided	Yes	No	5,900	12,000
Minor Collector (Share Use Path)	Transitioning	35 mph or lower	2	Undivided	No	No	4,600	9,600

* The service volume thresholds are based on the FDOT 2020 Multimodal Quality/Level of Service Handbook.

3.3 AREAS OF CONCERN

In order to better address traffic issues in Woods Cross, the analysis of the City was separated into recognizable areas with common concerns. These areas are as follows: Central and Industrial Area, 1500 South Corridor, North-South Corridors, East-West Corridors and Front Runner Station Access Area. A discussion of each of these areas follows.

3.3.1 Central & Industrial Area

To accommodate increasing traffic within the west side and industrial areas of Woods Cross, improvements will be needed to support both local access and regional freight movement. This portion of the city contains large industrial facilities, refineries, and rail-served properties, all of which generate significant truck activity. The presence of both the Union Pacific Main Line and the Spur Line create substantial east-west barriers, concentrating traffic onto only a few available crossings at 500 South, 1500 South, and 2600 South. As development continues, particularly within the 151-acre annexation area, additional roadway improvements, upgraded railroad crossings, and strengthened multimodal connections will be required to safely and efficiently move traffic into and out of the west side.

3.3.2 1500 South Corridor

The 1500 South corridor is expected to experience notable traffic growth through the 2050 horizon year. This corridor serves as a vital east-west connection linking Redwood Road, Mountain View Boulevard, 800 West, 1100 West, I-15, and US-89. Increased residential and commercial growth on the west side, combined with regional travel demands, will place

additional pressure on this corridor. Safety concerns have already been identified at multiple intersections, and early improvements, such as the installation of the traffic signal at 800 West, have contributed to reduction in crashes. Continued upgrades, including additional turn lanes, improved access management, and intersection control enhancements, will be needed to maintain acceptable operations and support long-term mobility along 1500 South.

3.3.3 North-South Corridors

North-south corridors in Woods Cross are essential for connecting neighborhoods, commercial districts, and industrial areas. Key routes such as Redwood Road, 500 West, 800 West, 1100 West, and Mountain View Boulevard are all expected to see increases in traffic volumes over time. These roads serve a mix of local and regional functions, including industrial access, commuter travel, and school circulation. As growth occurs along the west side and near the 500 South and 1500 South corridors, additional planning will be required to manage access, maintain roadway capacity, and improve safety. Enhancements may include widening, added turn lanes, and improved bicycle and pedestrian facilities to support multimodal connectivity.

3.3.4 East-West Corridors

East-West mobility in Woods Cross is limited by the railroad corridors and the Legacy Nature Preserve, which restrict the number of roads that can cross between the east and west sides of the city. The main east west corridors in Woods Cross are 500 South, 1500 South, and 2600 South. These roadways carry most of the city's east west traffic and will need long term improvements to maintain safe and efficient operations. As growth continues on the west side, these corridors may require widening, better intersections, and improved facilities for walking and biking.

2600 South is located along the southern boundary of Woods Cross. Woods Cross City boundary run just north of the roadway and the side streets 1560 West, 1500 West, 1425 West, 1260 West and other private driveways are within Woods Cross, while North Salt Lake City owns and maintains the roadway itself. Because Woods Cross and North Salt Lake City are connected at 2600 South, any future improvements along the roadway will need to be coordinated between both cities to ensure consistent design and safe travel for all users. Additional East-West connections may also be needed in the future to reduce pressure on these key routes.

3.3.5 FrontRunner Station Access Corridors

Access to the Woods Cross FrontRunner Station is constrained by the rail corridors and limited roadway connectivity. Improving multimodal access through enhanced sidewalks, shared use paths, improved crossings, and better north south bicycle routes will be essential for supporting transit ridership. The station area is expected to evolve through reinvestment and mixed-use development consistent with the City's General Plan. As this area grows, roadway improvements, refined access points, and coordinated land use planning will be necessary to ensure safe, direct, and convenient connections for pedestrians, bicyclists, transit users, and vehicles.

3.4 2050 TRAFFIC ANALYSIS

The traffic volumes used in the existing conditions analysis were projected to the year 2050 using growth trends identified in the WFRC travel demand models. Two 2050 models were created, a 2050 No Build model and a 2050 Build model. The 2050 No Build scenario uses the forecast 2050 traffic volumes but retains the existing roadway network. This scenario is used to identify locations where the future system is expected to exceed capacity. The 2050 Build scenario uses the same 2050 forecast volumes, but the roadway network includes planned improvements that address the deficiencies identified in the 2050 No Build scenario. This approach allows the City to evaluate future needs and determine which roadway upgrades will be necessary to support growth through the 2050 horizon year.

3.4.1 2050 No-Build

In the 2050 No Build scenario, the 1100 West / 1500 South intersection is expected to experience significant operational deficiencies. With all-way stop control, the intersection operates at an overall LOS F during both the AM and PM peak hours, with very high delays and long queues on all approaches.

The eastbound approach at the 1100 West / 1970 South intersection is also expected to operate poorly under 2050 No Build conditions. The eastbound 1970 South approach functions at LOS F in the AM peak hour and LOS C in the PM peak hour, reflecting substantial delay for traffic entering 1100 West.

All other analyzed intersections identified in Section 2.4 are expected to operate at LOS C or better under 2050 No Build conditions. **APPENDIX A: TRAFFIC COUNTS AND ANALYSIS** presents the 2050 No Build analysis details.

Additionally, the roadway network is projected to experience capacity deficiencies along several key corridors as traffic demand exceeds the capability of the existing roadway system. The most significant operational challenges occur along 1500 South near 800 West and along 800 West from 1500 South to 2600 South, where roadway segments are forecast to operate at LOSE/F, indicating unacceptable planning-level conditions. These corridors serve critical east-west and north-south functions, providing access to residential neighborhoods, industrial areas, and regional facilities, and are constrained by limited parallel routes and restricted east-west connectivity. Without improvements, these segments are expected to experience increased congestion, reduced travel speeds, and diminished reliability through the 2050 planning horizon.

In addition, a short segment along 2600 South is also projected to operate at LOSE/F under the No-Build scenario. This condition reflects higher traffic demand along a corridor that is shared with North Salt Lake, where regional through-traffic and limited alternative routes place added pressure on operations. While most other arterial and collector roadway segments in the City are projected to continue operating at LOS D or better, the failing segments along 1500 South, 800 West, and 2600 South highlight priority areas where future capacity and operational improvements will be necessary. Any improvements along 2600 South will require continued

coordination between Woods Cross and North Salt Lake to ensure consistent design, operations, and safe travel conditions. **Figure 4** summarizes the No-Build forecast daily traffic volumes and LOS for each planned functionally classified road within the City.

3.4.2 2050 Build

The 2050 Build scenario evaluates improvements intended to correct the deficiencies identified in the 2050 No Build scenario at the 1100 West / 1500 South and 1100 West / 1970 South intersections.

At the 1100 West / 1500 South intersection, the all-way stop control is replaced with a traffic signal and turn lane improvements are provided on the major approaches. With these upgrades, the intersection is expected to operate at an overall LOS B during both the AM and PM peak hours, with all approaches operating at LOS B or better.

At the 1100 West / 1970 South intersection, turn lane and minor geometric improvements are provided on the eastbound 1970 South approach while maintaining side street stop control. These upgrades reduce delays for the critical movement and improve overall operations, with the eastbound approach expected to operate at LOS D in the AM peak hour and LOS C in the PM peak hour. **APPENDIX A: TRAFFIC COUNTS AND ANALYSIS** presents the 2050 Build analysis details. Roadway segment LOS under the 2050 Build condition will be discussed further in **Section 5.1 ROADWAY AND INTERSECTION CONTROL** as part of the recommended roadway network improvements.

Figure 4: Year 2050 No-Build Daily Traffic Volumes and Level of Service

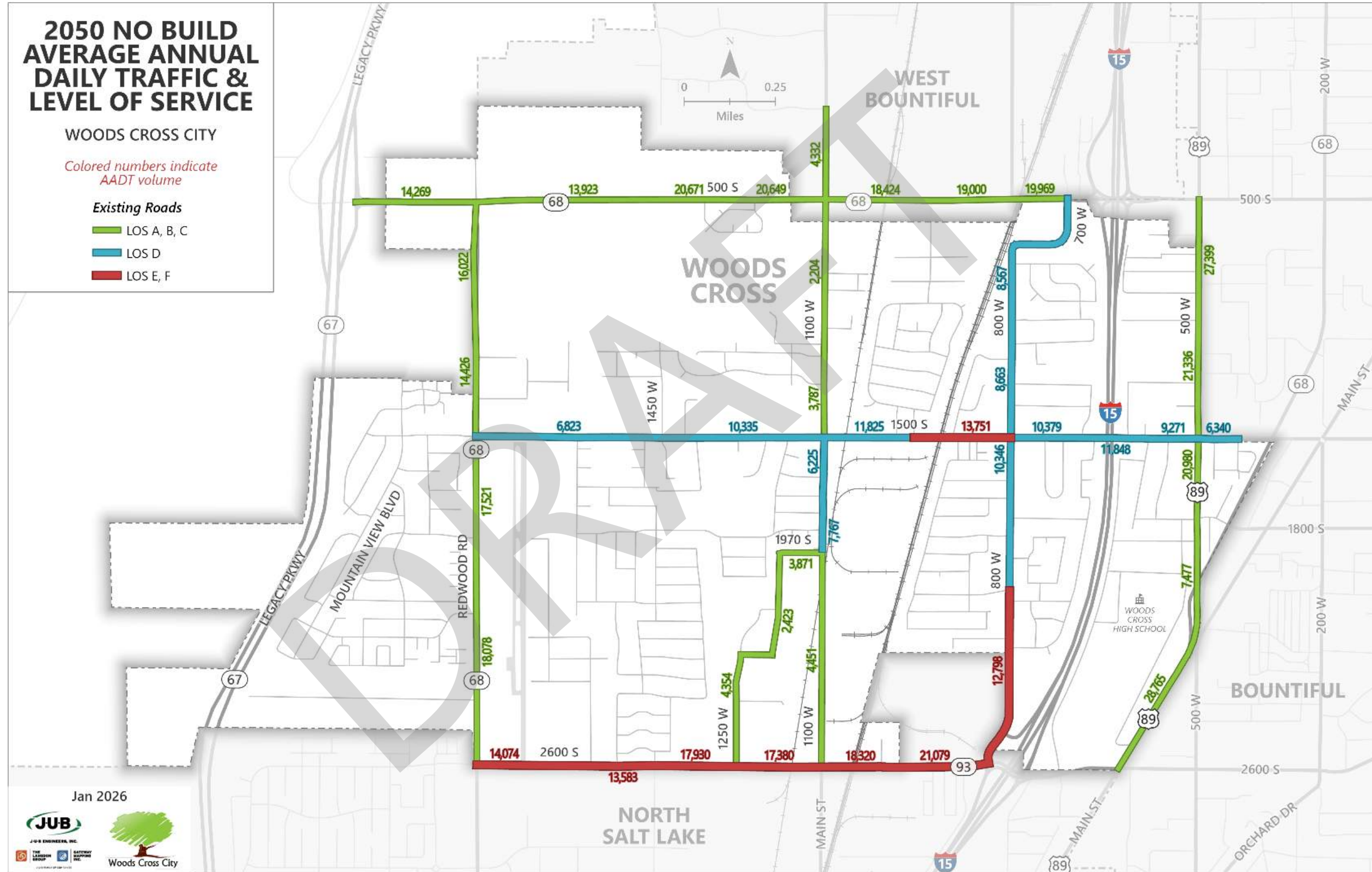

Jan 2026

JUB
J-U-B ENGINEERS, INC.

THE LARSON GROUP
LARSON GROUP

BATTERY GROUP
BATTERY GROUP

Woods Cross City

4. ACTIVE TRANSPORTATION

4.1 VISION AND GOALS

Woods Cross City has long prioritized active transportation infrastructure with a special emphasis on providing connectivity to important destinations within the community. In the 2013 version of the Parks and Trails Master Plan the city highlighted the need to maintain infrastructure that connects residents to schools, parks, trailheads, city buildings, churches, and other landmarks. The addition of new trails, wider sidewalks, and crossing countermeasures show the city's commitment to providing residents with safe and feasible multimodal transportation options.

Woods Cross City has adopted a few of the Davis County Active Transportation Plan goals, created in the 2024 county plan. The goals include a focus on improving access to key origins and destinations, creating safer facilities and crossings, and focusing on paths or trails. The city has provided feedback for many adjacent community and regional plans so the implementation of those plans is also a priority. These plans include the Davis County plan, West Bountiful plan, South Davis plan, Beehive Bikeways, and the Utah Trail Network. The increased desire from people for active transportation infrastructure across that state has been consistent with Woods Cross City residents as well.

4.2 EXISTING CONDITIONS

Woods Cross City has maintained robust mapping of their active transportation infrastructure since completing their Parks, Trails, and Open Space Master Plan in 2024. The data is maintained on the city GIS database and was updated for the purposes of this plan. **Figure 5** shows the trails, trailheads, and other related active transportation infrastructure within the city.

The city currently has about 4.75 miles of trails and sidewalk connectors, 3 trailheads, and 2 mid-block crossings that it maintains. In addition, the Legacy Parkway trail which is maintained by Davis County runs along the western edge of the city.

The existing infrastructure has a number of sizable gaps that are barriers for residents to easily use the infrastructure. The residential areas throughout the city are separated by barriers such as Interstate 15, railroad tracks, and the airport. These barriers make it difficult to move east and west within the city. The north and south collector roads have sidewalks only with no designated space for bicycles. Schools within the Woods Cross City boundary are shown in **Figure 5** and are well connected to the neighborhoods they serve but do have wide roadway crossings that create safety concerns, especially for younger children.

The Parks, Trails, and Open Space Master Plan completed by the City in 2024 identifies the walkable distances for each park and highlights specific improvements to provide better park

WOODS CROSS TRANSPORTATION MASTER PLAN

access to residents. The recommended improvements from the Parks, Trails, and Open Space Master Plan related to active transportation have been incorporated into this plan. The Utah Transit Authority owns and operates the Woods Cross FrontRunner station that provides an important asset to the city residents. The City recently completed a station area plan that specifically addresses improving multimodal access to the transit station. Improvements highlighted in that plan have also been incorporated into this plan.

Figure 5 shows a crash history for mild, severe, or fatal crashes from 2020 to 2024. Crash history was obtained via UDOT's Numetric website as well as the local police department. The city has one fatal crash during the identified period which occurred at US-89 and 1880 South. This is a UDOT roadway with potential safety improvements planned as part of an upcoming project.

DRAFT

Figure 5: Active Transportation – Existing Map

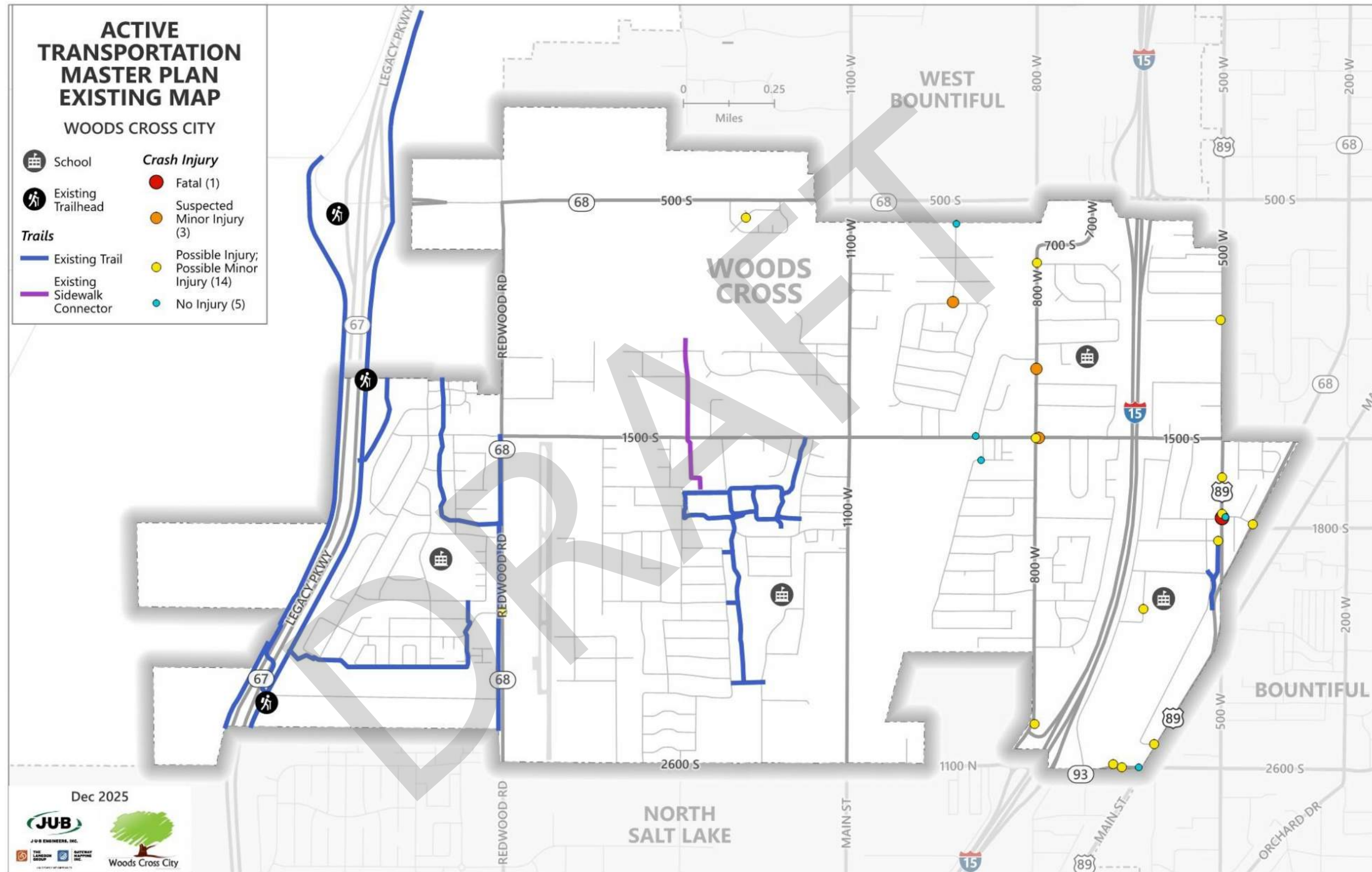

4.3 RECOMMENDATIONS

4.3.1 Projects

After an evaluation of the existing infrastructure and meetings with city staff, a number of projects were identified that accomplish the vision of the master plan and align with other master plans in the region. The proposed projects are shown in **Figure 6**, including trails, bikeways, sidewalk connectors, crossing improvements, and a pedestrian bridge. **Section 4.4.1 Prioritized list of actions or recommendations** contains a complete list of the recommended projects.

The trails identified in the map would generally be an asphalt surface with a width of 10-12 feet. Sidewalk connectors would generally be a concrete surface with a width of 5 or more feet. The bikeways would consist of a five-foot striped bike lane which would require elimination of parking on one side of the road as shown in **Figure 7**. The bike lanes would be added by modifying the existing pavement striping and would not require any physical changes to the roadway section. This provides the City with a realistic and cost-effective method for adding a bicycle space within the existing collector road cross sections. Crossing improvements would generally consist of adding rectangular rapid flashing beacons (RRFBs) at the intersection but would require additional evaluation to ensure the proposed countermeasure fits the roadway characteristics at the time of the project. The pedestrian bridge near the FrontRunner station is shown as part of the station area plan and is therefore included in this active transportation plan.

Figure 6: Future Active Transportation Projects

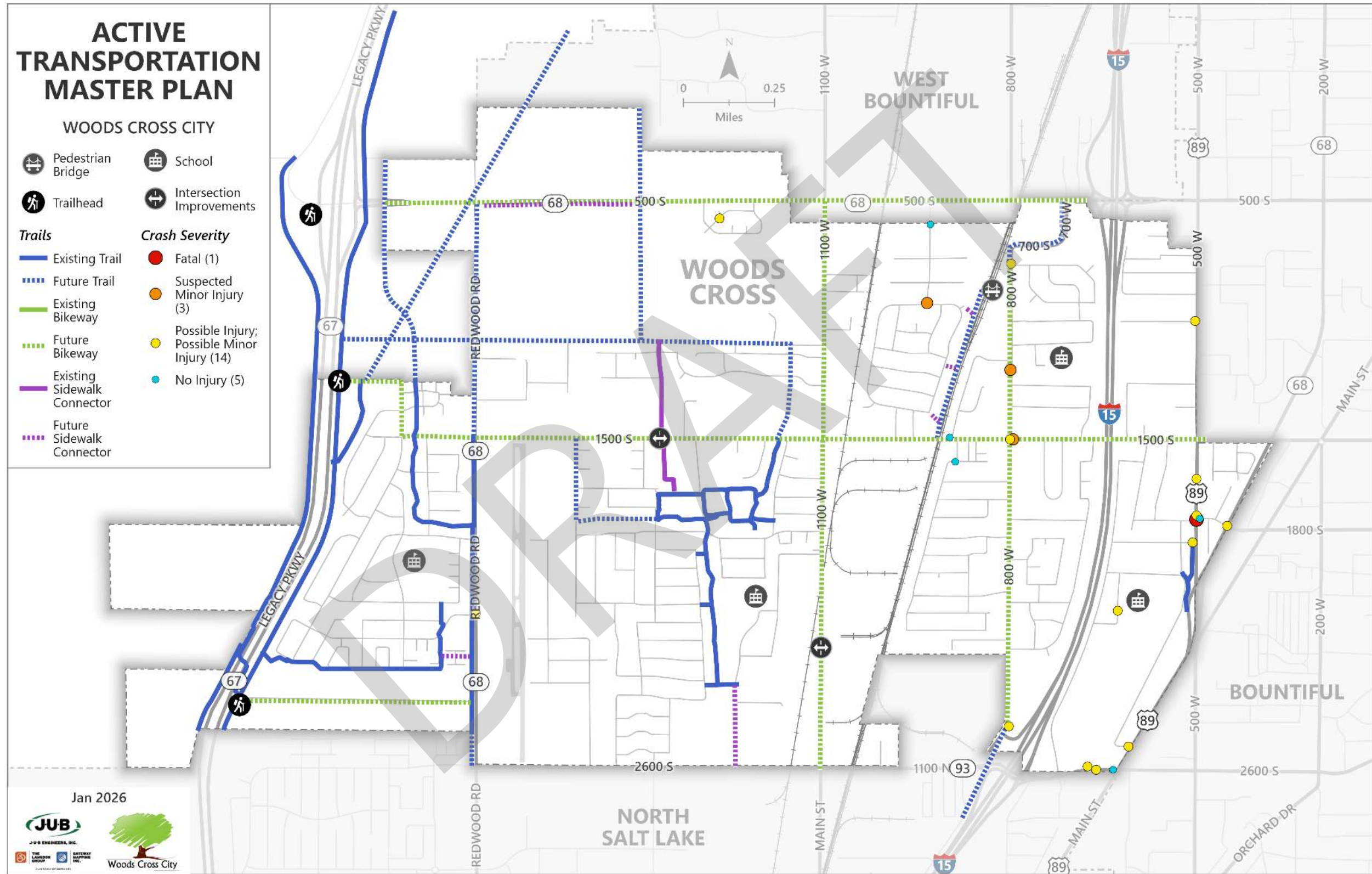
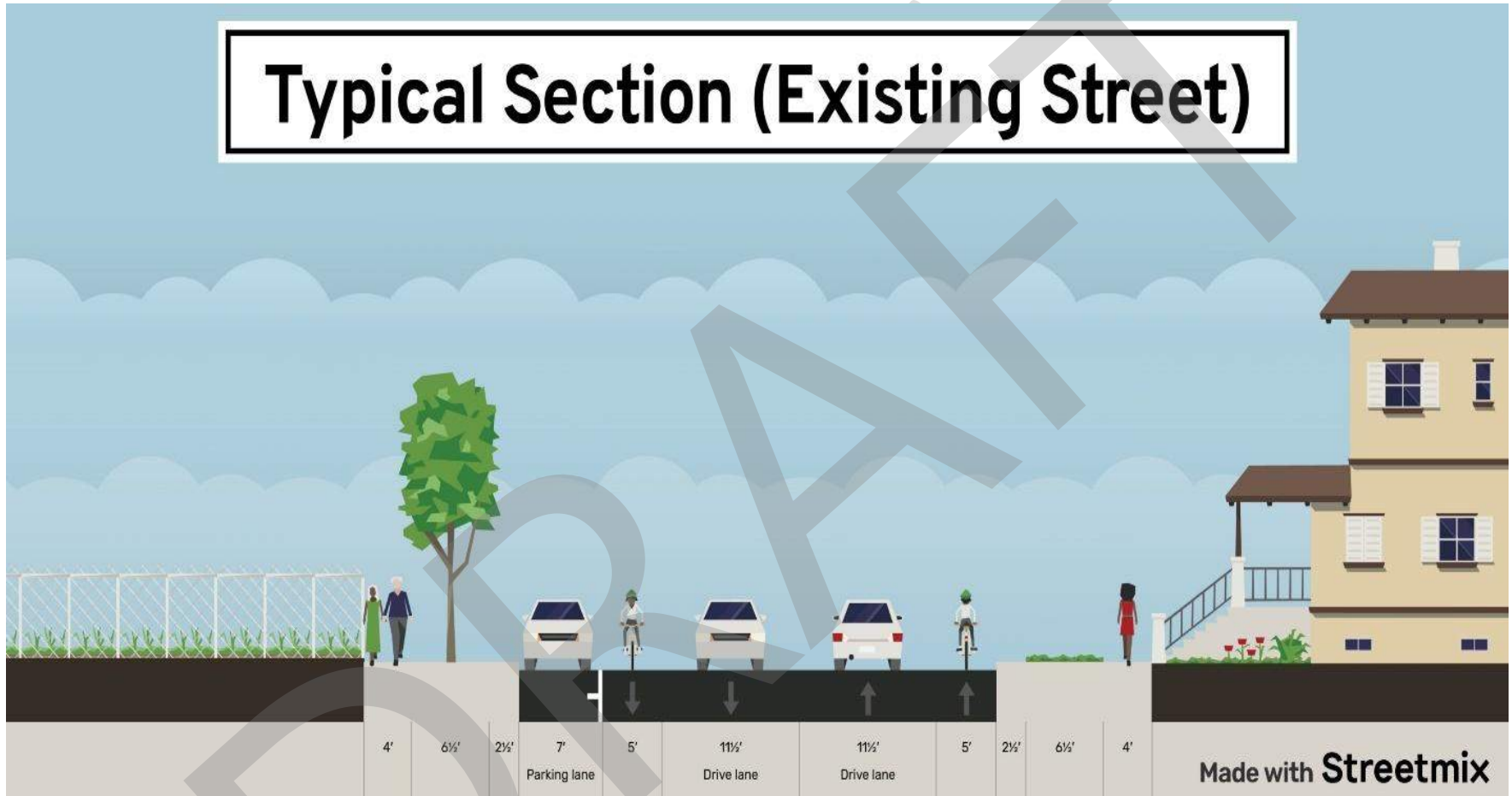

Figure 7: Bike Lane Option on Existing Street



4.3.2 Programs

Safe Routes to School programming is critical for the City and improvements related to safe routes are included in this plan. Woods Cross Elementary has a safe routes to school map which shows railroad tracks and collector roads as the major safety concerns. A new signalized intersection at 800 W 1500 S helps students to more safely navigate the intersection, with crossing guards utilized at all other crossings. Odyssey Elementary has a safe routes to school map which shows crossing guards utilized at minor collector road crossings and no other significant barriers. Woods Cross City plans to regularly evaluate school routes to ensure safety for students and works with UDOT to implement them.

In order to provide residents with a better understanding of the existing active transportation infrastructure and to plan out routes in advance, the city plans to post this master plan mapping online. The City may publish an online, navigable map that would provide even more functionality to residents. The City also plans to regularly update other county and statewide mapping databases with any infrastructure improvements to provide residents with up-to-date information on the existing facilities available to them.

4.3.3 Policies

Woods Cross City has a Special Provision in their Residential R-15/20 zoning ordinance which requires developers to incorporate active transportation infrastructure. The ordinance states, "To facilitate creation of a well-integrated, low-density single-family residence neighborhood, pedestrian and bicycle facilities and trails are required to ensure access to open space areas and regional trail systems", Woods Cross City Code, 12-7-103.

Woods Cross City also recently updated their design standards to increase the sidewalk width from 4 feet wide to 5 feet wide to provide additional space for pedestrians and ensure compliance with ADA requirements.

4.4 IMPLEMENTATION STRATEGY

4.4.1 Prioritized list of actions or recommendations

Table 7 provides a list of projects, sorted by their priority level, along with their estimated cost.

Table 7: AT Project List

Project #	Project Name	Path Type	Start	End	Length (ft)	Cost
0-5 Year Projects						
1	1100 West Bike Lane	Bike Lane	2600 S	500 S	7906	\$17,393.20
2	1500 South Bike Lane	Bike Lane	Mountain View Blvd	500 W	11648	\$25,625.60
3	A-1 Drain (1250 W)	Sidewalk	2600 S	2350 S	1197	\$77,805.00
5+ Year Projects						
4	500 S Sidewalk	Sidewalk	Redwood Road	1450 W	2170	\$141,050.00
5	Mountain View Bikeway	Buffered Bike Lane	1500 S	Park Trailhead	1701	\$102,060.00
6	2425 S Buffered	Buffered Bike Lane	Redwood Road	Foxboro Dog Park	3218	\$193,080.00
7	Farm Meadows Connector	Sidewalk	900 W	Fronrunner Trail	150	\$9,750.00
8	Valentine Estates Connector	Sidewalk	1875 W	Redwood Road	440	\$28,600.00
9	A-1 Drain West	Shared Use Path	1600 W	1425 W	1162	\$49,966.00
10	Fronrunner/Farm Meadows	Shared Use Path	1500 S	Fronrunner Station	2276	\$97,868.00
11	A-1 Drain Mountain View	Shared Use Path	1250 S	400 S	3347	\$143,921.00
12	A-2 Drain Kingston	Shared Use Path	1200 S	Highgate Ave	3377	\$145,211.00
13	A-2 Drain Argyle	Shared Use Path	1500 S	1200 S	3602	\$154,886.00
14	A-1 Drain, 1600 W	Shared Use Path	1850 S	1500 S	1204	\$51,772.00
15	Powerline Trail	Shared Use Path	Mountain View Park	Mill Creek	5872	\$252,496.00
16	A-1 Drain Valentine Estates	Shared Use Path	2135 S	1900 S	1239	\$53,277.00
17	Redwood Road	Shared Use Path	1500 S	500 S	3391	\$145,813.00
18	Redwood Road	Shared Use Path	2600 S	2600 S	515	\$22,145.00
19	1200 S	Shared Use Path	Redwood Road	1500 W (A-2 Drain)	2403	\$103,329.00
20	1200 S	Shared Use Path	Legacy Parkway	Redwood Road	1929	\$82,947.00
21	Farm Meadows Bridge	Bridge	Farm Meadows	Fronrunner Station	250	\$12,000,000.00
22	1500 S 1450 W	Intersection Improvements				\$24,000.00

4.4.2 Capital and Maintenance Costs & Budgets

The City currently allocates \$2,000 - \$4,000 per year towards the maintenance and preservation of the existing active transportation infrastructure. Trails are crack sealed as needed, with a high-density mineral bond surface treatment added every 5-8 years. Parking lots for trail heads also receive pavement preservation work on a regular basis. Restrooms and other amenities at trailheads are maintained by the Parks Department. It is recommended for the City to continue its current maintenance plan for the asphalt trails and parking lots, repair concrete sidewalk/ trails as-needed, and regularly service the restrooms/ trailhead amenities.

The City does not currently have any regularly dedicated funding for capital improvements related to active transportation infrastructure. As projects are identified and outside funding is obtained, the city generally allocates a portion of their streets budget to cover the remaining cost of the project. One time funding allocations are also used from the general City budget when required.

4.4.3 Funding Opportunities

The following funding opportunities are available to Woods Cross City for active transportation projects. There are a number of the projects shown in the master plan that are also included in the Davis County Active Transportation Master Plan and the Utah Trail Network Master Plan which provides a strong opportunity to apply for funding.

- Local tax money (RAP)
- Davis County Proposition 1
- Utah Outdoor Recreation
- Utah Trail Network (UDOT UTN)
- WFRC TAP
- WFRC ATIF
- WFRC TIF Active

4.5 PERFORMANCE MEASURES

The primary performance measure used by Woods Cross City is health indicators including crashes and safety figures. Crashes and reported safety concerns are promptly evaluated by the City to determine what actions, if any, are best to ensure the safe use of facilities. The Legacy Parkway trail is the only high-profile location that potentially merits collection of count data for trail use which is something being evaluated at a County level. Woods Cross City may evaluate other locations for collecting count data in the future if public use increases.

5. RECOMMENDATIONS

Transportation network upgrades were determined by evaluating the proposed 2050 functionally classified road network and reviewing existing and planned intersection traffic control devices. These improvements are based on the traffic volume forecasts from the 2050 travel demand modeling.

5.1 ROADWAY AND INTERSECTION CONTROL

Figure 8 & Figure 9 show the recommended functional classification system, number of lanes, Annual Average Daily Traffic (AADT), and LOS respectively for Woods Cross.

In anticipation of projected increases in traffic volumes, only two intersections have been identified as suitable candidates for the installation of either a traffic signal or a roundabout. Based on discussions with the City, a roundabout is recommended for implementation at Mountain View Blvd. / 2260 South, even though current yield control is adequate under the build condition. The selected intersections are listed below:

- 1100 West / 1500 South (Signalized)
- Mountain View Blvd. / 2260 South (Roundabout)

Improvements to the intersection traffic control will reduce congestion, increase safety, and improve mobility throughout the transportation network. The type of traffic control device considered for implementation at each intersection in the future, whether it be a traffic signal; roundabout; or other device, should be determined by a traffic study before implementation.

To enhance key roadway segments and address No-Build deficiencies projected in the 2050 Build scenario, the primary strategy is to upgrade the functional classification and capacity of targeted corridors. Segments that have experienced operational issues, such as portions of 1500 South and 800 West, will be improved through revised functional classifications, optimized lane configurations, and improved corridor continuity. These upgrades are intended to ensure the roadway network matches forecasted traffic volumes, resulting in corridor-level operations of LOS D or better.

However, a short segment along 2600 South is expected to continue operating at LOS E/F under the Build scenario due to high regional traffic demand along this corridor, which is shared with North Salt Lake. Any future improvements for this area will require collaboration between Woods Cross City and North Salt Lake to effectively address capacity needs.

Overall, the roadway network is anticipated to generally meet future demands under the build condition, supporting projected growth while aiming to reduce congestion and improve safety and mobility throughout the city. However, ongoing monitoring and adjustments may be necessary to address unforeseen challenges or changes in traffic patterns.

5.2 STREET STANDARDS

Street standards reflect the goals of the City and the typical roadway cross sections. **Table 8** summarizes the street standards for Woods Cross City. Typical sections for arterial and collector are in **APPENDIX D: ARTERIAL AND COLLECTOR TYPICAL SECTIONS**.

Table 8: Summary of Typical Roadway Cross Sections

Function Class	ROW	Pavement	Park Strip	Sidewalks	Trail
Principal Arterial (UDOT)	102'	74'	6.5'	5'	-
Minor Arterial	82'	54'	6.5'	5'	-
Major Collector	68'	41'	5.0'	5'	-
Minor Collector (City)	68'	41'	5.0'	5'	-
Major Collector (City - Share Use Path)	68'	35'	5.5'	5'	10'
Local	58'	30'	6.5'	5'	-

All streets shall be required to meet the Woods Cross City standard cross sections as identified in the Plan.

Modification of these standards may be recommended on a case-by-case review by the City Engineer based on the existing and proposed roadway function, proximity to intersections and access points, crash history, transition to existing roadways, and related technical criteria as deemed applicable by the City Engineer. The City may require higher standards, based on best engineering judgment related to the safe operation and progression of traffic flow.

Intersections of collector streets and higher road classification shall be reviewed for the need for turn lanes and other geometric improvements. The City Engineer may recommend alternative standards when those standards can be demonstrated to provide better traffic flow and safer operation. The City Engineer provides technical review for the City, as final decisions and appeals rest with the Woods Cross City Council.

Figure 8: 2050 Functional Classification and Intersection Control

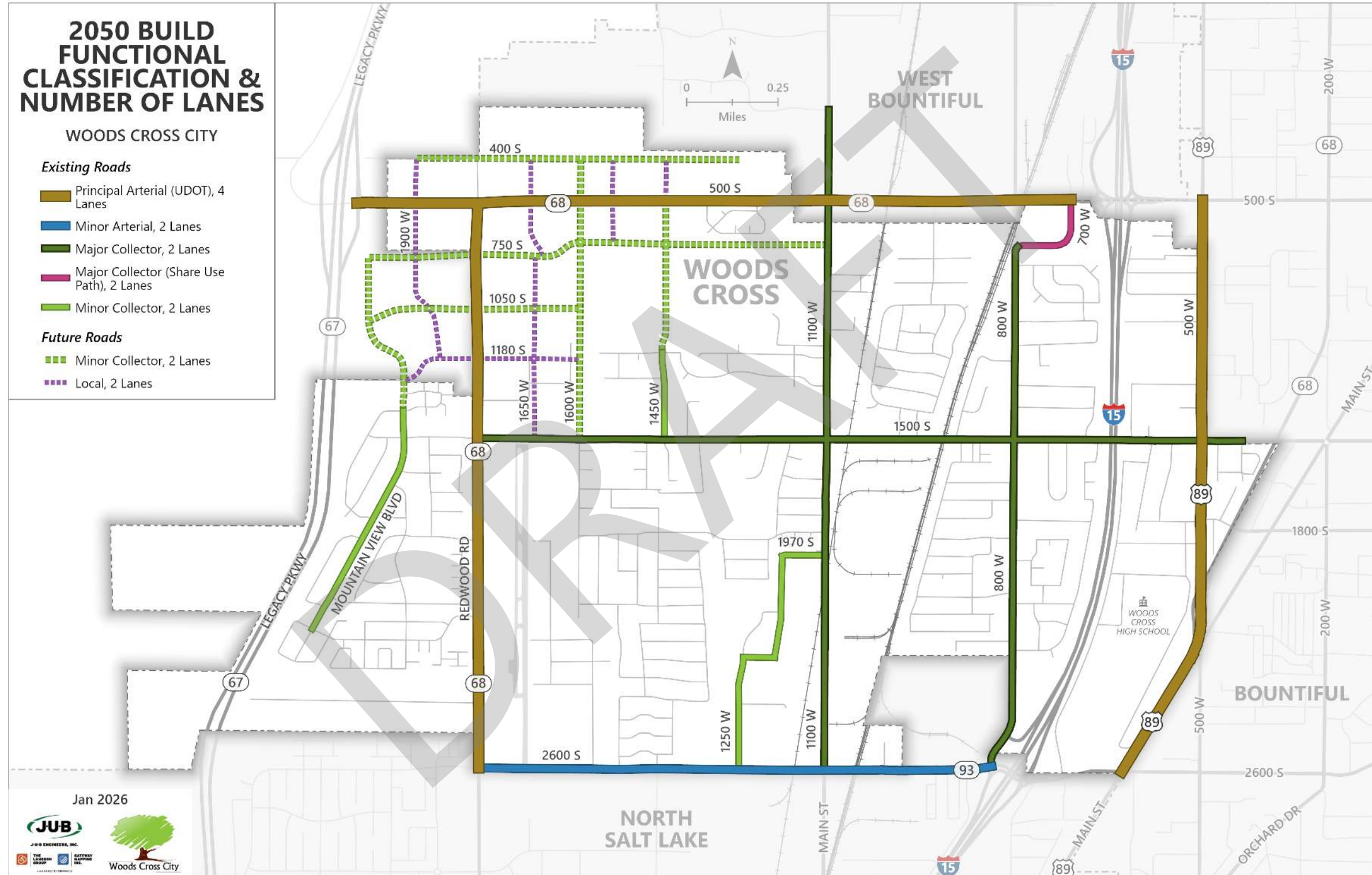

Jan 2026



Figure 9: 2050 AADT/LOS

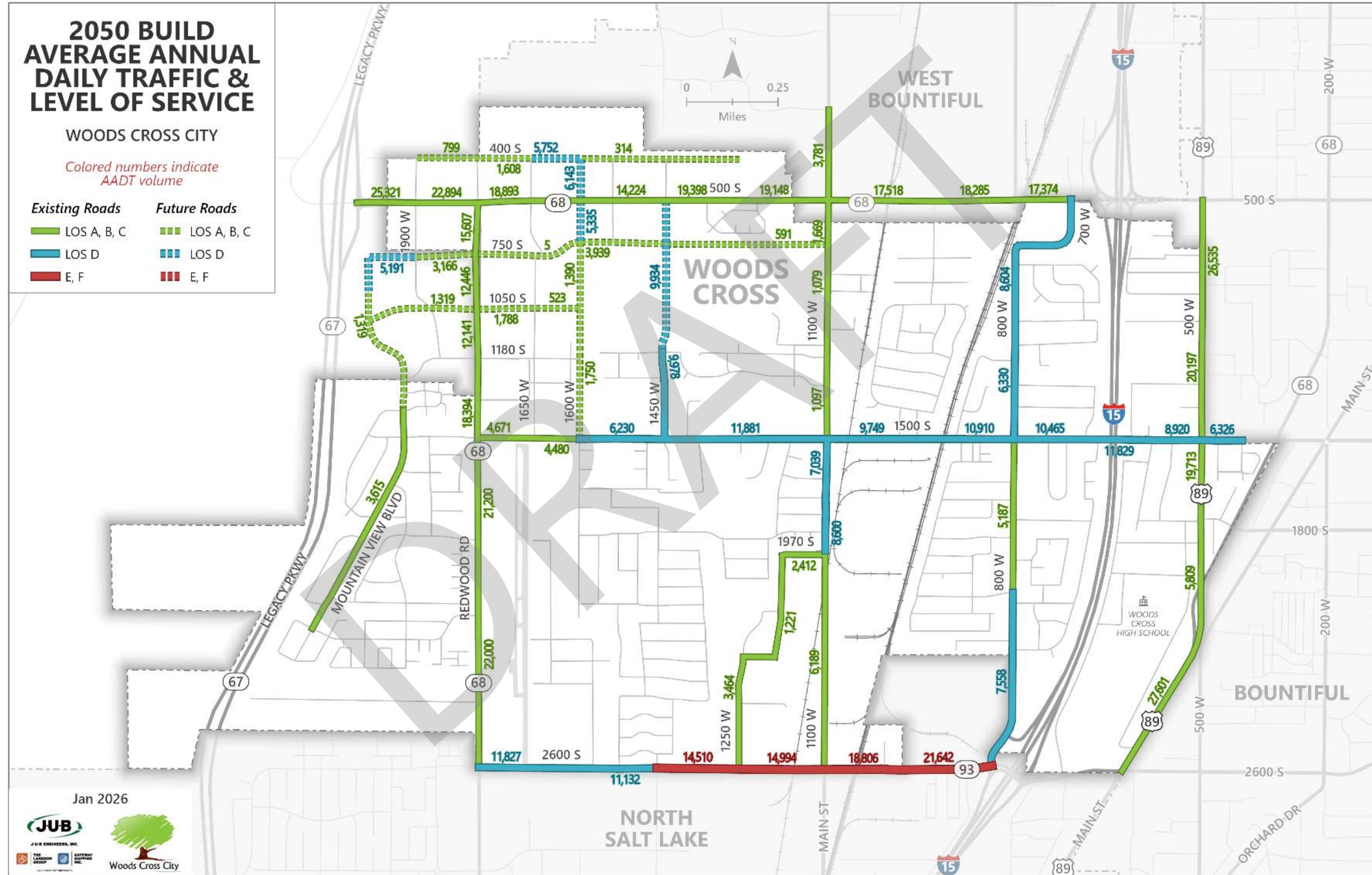

5.3 ACCESS MANAGEMENT

Access management is an important tool in transportation planning. Access management is the planning, design and implementation of land use and transportation strategies to maintain a safe flow of traffic on roadways while accommodating the access needs of adjacent developments. The concept involves maximizing the efficiency of arterial and collector corridors by limiting or consolidating driveways or access points. By requiring adjacent land to be accessed from facilities with lower functional classifications, traffic conflicts caused by turn movements onto and off of key roadways are consolidated and reduced.

The benefits of access management include increased capacity, maintenance of traffic flow and speed, improved safety, and preservation of infrastructure investment. By employing access management techniques, roadways can better fulfill their intended function for a longer period of time, maximizing capacity and reducing the need for expensive infrastructure investments in the future through the addition of travel lanes.

Where practical, the future collectors and arterials identified in the Transportation Master Plan should be managed with coordinated access control as follows:

- Maintain 35 mph speed limits or higher to promote mobility.
- Signals spaced at 1,320 to 2,640 feet, where possible, on collectors and arterials, respectively.
- Local street intersections spaced at 660 feet.
- Driveways spaced at 350 feet.
- Street parking limited or none.
- Separated pathways or sidewalks.
- Separate bike paths adjacent to the travel lanes.

Table 9 summarizes additional access management considerations for regional corridors, based on spacing guidance from the Access Management Manual, second edition; Access Management Application Guidelines; and UDOT Administrative Rule R930-6.

Table 9: Additional Access Management Criteria for Regional Corridors

Functional Classification	Access Management
Minor Arterial	Arterials have limited access. Side street access and 350' min. spacing for driveways. No new individual residential access.
Major Collector (Residential)	Street access only preferred, with 200' average driveway spacing with min. 150' spacing.
Major Collector (Commercial/Industrial)	300' min. spacing (shared accesses).
Minor Collector (Residential)	No parking instead of limiting access points. Street access preferred.
Minor Collector (Commercial/Industrial)	Shared access. 200' min. spacing.

5.4 ROADWAY LIGHTING

According to AASHTO’s Geometric Design of Highways and Streets, Good visibility under both day and night conditions is fundamental to enabling motorists, pedestrians, and bicyclists to travel on roadways in a safe and coordinated manner. Properly designed and maintained street lighting should provide comfortable and accurate night visibility, which should facilitate vehicular, bicycle and pedestrian traffic. Decisions concerning appropriate street lighting should be coordinated with safety management, crime prevention, and other community concerns. The latest AASHTO publication **Roadway Lighting Design Guide (2018)** provides discussion on street and roadway lighting.

Properly designed lighting can provide improved safety. Additionally, lighting improvements enhance and improve roadway Level of Service, as vehicles can flow more freely when proper lighting conditions are provided. Street lighting should be included on all streets classified as collectors or arterials. These elements are recommended to be implemented with all roadways being improved and for roadways that currently do not have lighting facilities. Lighting can also provide attractive gateway features or entrances to specific areas or demarcating the City boundary. Lighting should also be considered on state highways within the City for consistency and continuity with City lighting standards.

5.5 TRANSIT

Transit plays an important role in providing regional mobility and supporting a balanced transportation system for Woods Cross City. While the roadway network will continue to accommodate the majority of daily travel, transit services offer essential alternatives for commuters traveling to major employment and activity centers throughout Davis and Salt Lake Counties. Reliable transit options help reduce congestion, improve air quality, and provide equitable access for residents who may not drive.

WOODS CROSS TRANSPORTATION MASTER PLAN

Woods Cross is currently served by the UTA FrontRunner commuter rail, with the Woods Cross Station providing direct connections to Ogden, Salt Lake City, Provo, and intermediate destinations. The station is a key asset for the community and is identified in the Woods Cross General Plan as a priority focus area for station-area access, mixed-use development, and improved pedestrian and bicycle connectivity. UTA bus service also operates along key corridors such as 500 South, Redwood Road, and US-89, offering additional east–west and north–south mobility and connectivity within South Davis County.

The WFRC 2023–2050 Regional Transportation Plan (RTP) includes several improvements that will benefit Woods Cross and the surrounding region. These include continued FrontRunner North service enhancements, capacity upgrades, and frequency improvements to support ongoing ridership growth. The RTP also identifies future high-frequency “core bus” corridors in southern Davis County, which will enhance reliability and expand transit access for residents traveling to neighboring communities and downtown Salt Lake City. As regional demand grows, the RTP anticipates expanded service hours, improved weekend operations, and periodic updates to local bus routes.

While no premium transit investments are currently programmed specifically within Woods Cross, the RTP emphasizes long-term corridor preservation for future transit improvements. This ensures that as the area grows, opportunities remain for enhanced bus, BRT, or other transit-supportive infrastructure. Woods Cross City will benefit from ongoing coordination with UTA, UDOT, and WFRC to ensure that future development patterns, street layouts, and active transportation connections support access to regional transit services.

Overall, transit will continue to complement the roadway and active transportation networks by providing regional mobility, supporting economic development, and improving travel options for Woods Cross residents. Continued planning and multimodal coordination will help ensure that transit remains an effective component of the City’s long-range transportation system.

6. CAPITAL IMPROVEMENT PLAN

6.1 CAPITAL IMPROVEMENT PLAN

The proposed roadway and pedestrian improvements vary from small improvements to complete sidewalks on existing roadways to larger projects such as new roadways and roadway widening.

Based upon input from City staff, improvements have been grouped into projects to be completed within the next five years (2026-2031) and greater than 5 years. A second public open house was conducted on January 21, 2026 to gather public input. A summary of the Community Engagement and two Open Houses is included in **APPENDIX E: COMMUNITY ENGAGEMENT**. The attendance at the second open house was sparse and no written public input was received from attendees on the CIP. Projects are listed in general terms and are not ranked. Improvements are shown in **Table 10** and **Table 11**.

Project priorities will change as the local area develops. Additionally, the planning horizon is 24 years. Many issues that are not anticipated today will affect project prioritization in the future. These major projects have been identified and cost estimates developed as a means of planning for the future and ensuring that local development plans are coordinated within the overall regional transportation plan. Each project will require further study and needs to be programmed into City's long-range budgets. These projects should be individually evaluated in more detail and constructed as required to support continued development of the City. Cost estimates for each project are included in **APPENDIX F: PROJECT COST ESTIMATES**. **Figure 10** shows the Capital Improvement Plan for the future.

Figure 10: Capital Improvement Plan

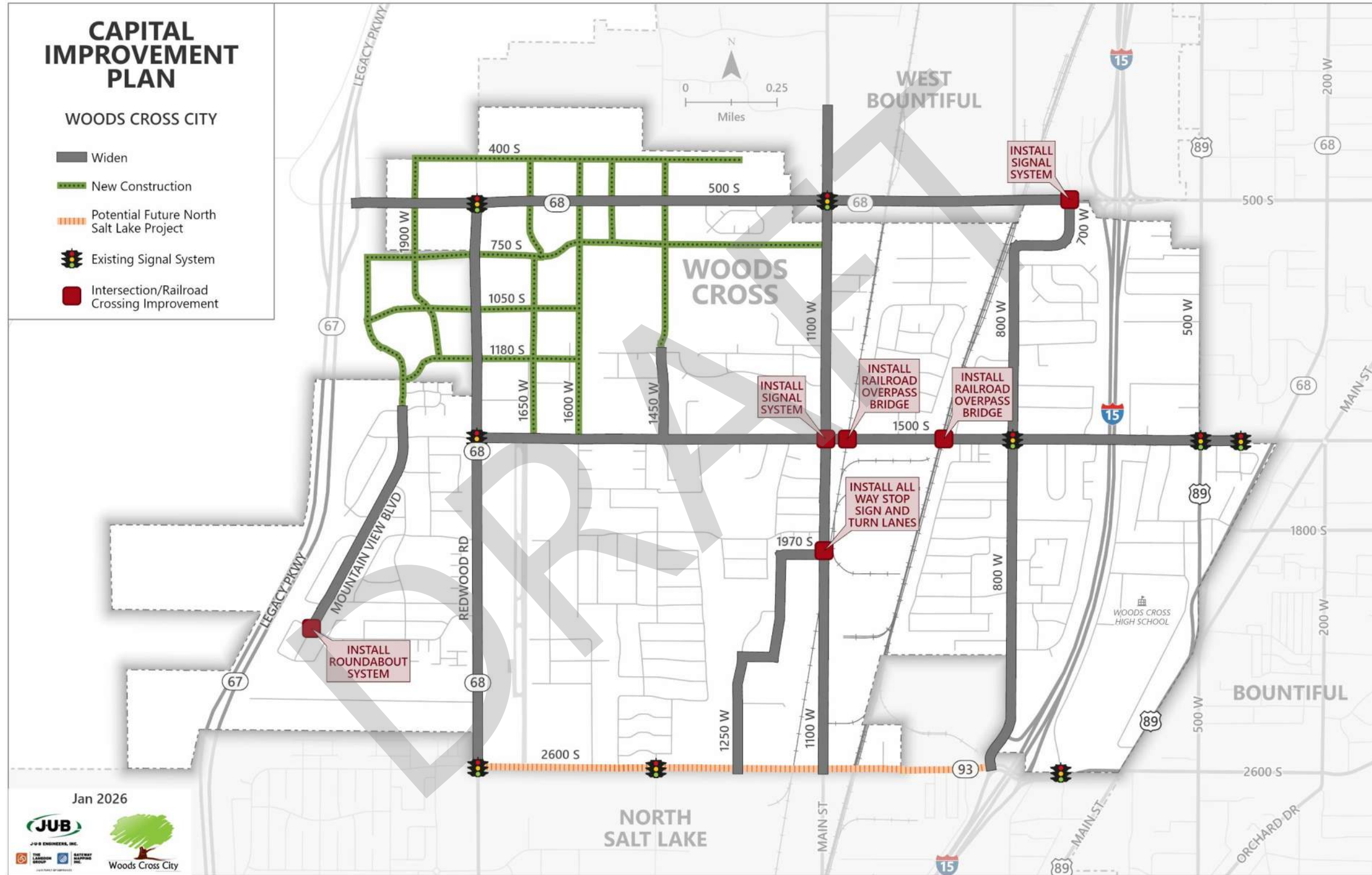

WOODS CROSS TRANSPORTATION MASTER PLAN

Table 10: Transportation Improvement Projects 0-5 Years

0-5 Year Projects					
Street	From	To	Function Class	Project	Construction Cost (2025\$)
1100 W	1970 S	2600 S	Major Collector	Widen	\$10,218,000
800 W	1500 S	2100 S	Major Collector	Widen	\$7,420,000
1500 S	1600 W	1470 W	Major Collector	Widen	\$3,041,800
1500 S/1100 W	-	-	Intersection	Install Signal System	\$ 300,000 (Signal)
1970 S/1100W	-	-	Intersection	Install Turn Lanes	\$ 860,800 (Turn Lanes)
Mountain View Blvd/2260 S	-	-	Intersection	Install Roundabout	\$ 300,000 (Roundabout)

Table 11: Transportation Improvement Projects 5+ Years

5+ Year Projects					
Street	From	To	Function Class	Project	Construction Cost (2025\$)
1250 W	1950 S	2275 S	Minor Collector (City)	Widen	\$5,612,400
1250 W	2275 S	2600 S	Minor Collector (City)	Widen	\$4,998,000
1100 W	50 S	500 S	Major Collector	Widen	\$6,061,100
1100 W	500 S	750 S	Major Collector	Widen	\$2,607,400
1100 W	750 S	1125 S	Major Collector	Widen	\$4,371,500
1100 W	1125 S	1500 S	Major Collector	Widen	\$4,836,000
1100 W	1500 S	1850 S	Major Collector	Widen	\$3,754,700
1100 W	1850 S	1970 S	Major Collector	Widen	\$1,778,600
700 W	500 S	700 S	Major Collector (City - Share Use Path)	Widen	\$1,795,700
700 S	700 W	800 W	Major Collector (City - Share Use Path)	Widen	\$1,890,400
800 W	700 S	1000 S	Major Collector	Widen	\$3,768,700
800 W	1000 S	1500 S	Major Collector	Widen	\$5,706,600
800 W	2100 S	2400 S	Major Collector	Widen	\$6,036,200
800 W	2400 S	2600 S	Major Collector	Widen	\$2,472,200
1500 S	Redwood Rd	1650 W	Major Collector	Widen	\$4,264,100

WOODS CROSS TRANSPORTATION MASTER PLAN

1500 S	1650 W	1600 W	Major Collector	Widen	\$409,000
1500 S	1470 W	1450 W	Major Collector	Widen	\$708,300
1500 S	1450 W	1100 W	Major Collector	Widen	\$8,108,900
1500 S	1100 W	950 W	Major Collector	Widen	\$4,381,700
1500 S	950 W	800 W	Major Collector	Widen	\$4,779,500
1500 S	800 W	675 W	Major Collector	Widen	\$3,569,000
1500 S	675 W	580 W	Major Collector	Widen	\$3,098,800
1500 S	580 W	US-89	Major Collector	Widen	\$2,248,700
1970 S	US-89	400 W	Major Collector	Widen	\$3,463,200
1970 S	1250 W	1175 W	Minor Collector (City)	Widen	\$1,769,200
1950 S	1175 W	1100 W	Minor Collector (City)	Widen	\$1,168,300
2600 S	Redwood Rd	1700 W	Minor Arterial	work with NSLC	\$0
2600 S	1700 W	400 W	Minor Arterial	work with NSLC	\$0
2600 S	400 W	1250 W	Minor Arterial	work with NSLC	\$0
2600 S	1250 W	1100 W	Minor Arterial	work with NSLC	\$0
2600 S	1100 W	950 W	Minor Arterial	work with NSLC	\$0
2600 S	950 W	850 W	Minor Arterial	work with NSLC	\$0
2600 S	850 W	800 W	Minor Arterial	work with NSLC	\$0
400 S	1900 W	1775 W	Minor Collector (City)	New Construction	\$2,121,200
400 S	1775 W	1650 W	Minor Collector (City)	New Construction	\$1,303,000
400 S	1650 W	1625 W	Minor Collector (City)	New Construction	\$500,000
400 S	1625 W	1600 W	Minor Collector (City)	New Construction	\$520,100
400 S	1600 W	1525 W	Minor Collector (City)	New Construction	\$1,576,000
400 S	1525 W	1450 W	Minor Collector (City)	New Construction	\$1,260,800
400 S	1450 W	1275 W	Minor Collector (City)	New Construction	\$5,216,500
750 S	Mountain View Blvd	2000 W	Minor Collector (City)	New Construction	\$909,100
750 S	2000 W	1900 W	Minor Collector (City)	New Construction	\$1,909,100
750 S	1900 W	Redwood Rd	Minor Collector (City)	New Construction	\$2,151,500
750 S	Redwood Rd	1650 W	Minor Collector (City)	New Construction	\$2,080,300
750 S	1650 W	1600 W	Minor Collector (City)	New Construction	\$1,670,600
750 S	1600 W	1525 W	Minor Collector (City)	New Construction	\$2,332,500
750 S	1525 W	1450 W	Minor Collector (City)	New Construction	\$1,670,600
750 S	1450 W	1275 W	Minor Collector (City)	New Construction	\$4,255,200
750 S	1275 W	1100 W	Minor Collector (City)	New Construction	\$3,515,100
1050 S	Mountain View Blvd	2000 W	Minor Collector (City)	New Construction	\$909,100
1050 S	2000 W	1900 W	Minor Collector (City)	New Construction	\$1,909,100

WOODS CROSS TRANSPORTATION MASTER PLAN

1050 S	1900 W	Redwood Rd	Minor Collector (City)	New Construction	\$2,151,500
1050 S	Redwood Rd	1650 W	Minor Collector (City)	New Construction	\$2,080,300
1050 S	1650 W	1600 W	Minor Collector (City)	New Construction	\$1,670,600
1600 W	400 S	500 S	Minor Collector (City)	New Construction	\$969,700
1600 W	500 S	750 S	Minor Collector (City)	New Construction	\$2,999,900
1600 W	750 S	900 S	Minor Collector (City)	New Construction	\$1,393,900
1600 W	900 S	1050 S	Minor Collector (City)	New Construction	\$1,733,600
1600 W	1050 S	1115 S	Minor Collector (City)	New Construction	\$488,600
1600 W	1115 S	1180 S	Minor Collector (City)	New Construction	\$693,500
1600 W	1180 S	1500 S	Minor Collector (City)	New Construction	\$3,309,600
1450 W	1200 S	1500 S	Minor Collector (City)	Widen	\$3,700,000
1450 W	500 S	750 S	Minor Collector (City)	New Construction	\$2,999,900
1450 W	750 S	1200 S	Minor Collector (City)	New Construction	\$4,151,400
Mountain View Blvd	750 S	900 S	Minor Collector (City)	New Construction	\$1,393,900
Mountain View Blvd	900 S	1050 S	Minor Collector (City)	New Construction	\$1,666,600
Mountain View Blvd	1050 S	1115 S	Minor Collector (City)	New Construction	\$469,700
1500 S/Spur Railroad	-	-	Intersection	Install Railroad Overpass Bridge	\$7,700,000*
1500 S/UTA Railroad	-	-	Intersection	Install Railroad Overpass Bridge	\$7,700,000*

*The cost estimate for the 1500 South/UTA Railroad comes from WFRC RTP project data. The overpass bridge for the 1500S/Spur Railroad should cost about the same, but it might be cheaper because it's shorter. Final costs for both will be set during construction.

6.2 WOODS CROSS CONNECTIVITY PLAN (MANDATED BY SENATE BILL 195)

The Utah Senate Bill (SB) 195 has required all municipalities within a Metropolitan Planning Organization (MPO) to amend the transportation and circulations element of their General Plans to identify and include priority transportation connections on or before July 1, 2027.

SB-195 provides an opportunity to municipalities to identify priority transportation connections, in consultation with stakeholders, that remedy physical impediments like water conveyances (rivers, canals, drainage channels, etc) and other physical barriers like railroads and roadways bisected by freeways. These transportation connections would improve circulation and enhance vehicle, transit, bicycle and pedestrian (multi-modal) access to significant economic (employment centers), educational (schools, universities, libraries, etc.), recreational (parks and other City/regional amenities), and other priority destinations like transportation hubs (UTA FrontRunner station), and commercial areas.

WOODS CROSS TRANSPORTATION MASTER PLAN

For each priority connection, SB-195 requires each municipality to identify estimated costs, potential funding sources (private, local, state and federal) along with impediments for construction of the priority connections. WFRC would then, in consultation with municipalities with the MPO, report to a Transportation Interim Committee on status of municipal modifications to General Plans, the status of a regional grid network study, physical and other impediments to constructing the priority connections along with potential funding sources to make transportation connectivity improvements.

In order to identify the priority connections, the City met with WFRC and reviewed aerial maps, feasibility/constraints for each connectivity project. In addition, active transportation crash data was collected and hot spot analyses were also conducted based on available data. Planning level cost estimates were prepared for each identified priority connection.

Using the available transportation data, crash data, future roadway network for vacant land (northwest quadrant), and future land-use data for Woods Cross, barriers and constraints to the network connectivity were identified. Those included rivers, canals, creeks, freeways (Legacy Highway, and I-15) and primary arterials (SR-68 and US-89), Skypark Airport, Union Pacific and Utah Transit Authority rail lines, spur rail lines, conservation areas, land ownerships (and development constraints) and other gaps in the active transportation network (trails, sidewalks, bikeways/lanes, and crossings). With these constraints, four specific Projects were identified and described below and shown in **Figure 11 SB-195 Projects TMP List**.

Priority Project#1 – Tunnel Under Skypark Airport: This priority project includes a pedestrian tunnel under Skypark Airport at approximately 2135 South connecting the residential communities on the east side of the airport with the residential communities and trails on the west side of Redwood Road (SR-68). This connection is needed for economic and Regional Connectivity purposes. The biggest impediment is Skypark Airport which occupies land between 1500 South and 2600 South along Redwood Road (SR-68) – approximately 4,725 feet with no pedestrian or roadway connections. An overpass is infeasible due to FAA regulations for the Skypark Airport that do not allow overhead connections through the Runway Protection Zone (RPZ) due to height restrictions. This would require a tunnel approximately 1,500 feet in length, which would be cost prohibitive. The entry and exist points of the tunnel would need to be established, but will potentially impact homes located along 1600 West to provide this regional connection. The funding sources for this would need to be Federal (ATIIP – Active Transportation Infrastructure Investment Program; CRP - Carbon reduction Program; CMAQ – Congestion Mitigation and Air Quality Improvement Program; RAISE – Rebuilding American Infrastructure with Sustainability and Equity; and STBG – Surface Transportation Block Grant Program) or State (TIF Active; TTIF First and Last Mile; UTN) funds.

Priority Project#2 - Pedestrian Bridge over Union Pacific Rail Road (UPRR): This priority project was identified in the latest Station Area Plan. It includes an overhead pedestrian bridge at approximately 925 South over the Union Pacific Rail Road connecting the residential on the

WOODS CROSS TRANSPORTATION MASTER PLAN

west side with the UTA FrontRunner Station on the east side of the UPRR line. The biggest impediment is the UPRR line. UTA FrontRunner Station is a priority destination within Woods Cross and neighboring communities. It would be cost prohibitive to build a tunnel under UPRR and would also potentially generate public opposition. The funding sources for this would need to be Federal (ATIIP – Active Transportation Infrastructure Investment Program; CRP - Carbon reduction Program; CMAQ – Congestion Mitigation and Air Quality Improvement Program; RAISE – Rebuilding American Infrastructure with Sustainability and Equity; and STBG – Surface Transportation Block Grant Program) or State (TIF Active; TTIF First and Last Mile; UTN) or other UTA funds.

Priority Project#3 - 800 West to 2600 South - Bridge Connection with Shared Use Trail:

This priority project was identified in the EIS that was recently completed for I-15 between Salt Lake City to Farmington. As part of the I-15/2600 South interchange reconfiguration, 800 West roadway would be elevated over 2600 South and connected to Overland Road in North Salt Lake City. This connection is needed for economic and Regional Connectivity purposes. A 10-foot shared use trail will be added over the reconfigured 800 West roadway section. The biggest impediment to this regional vehicular and active transportation connection is the proximity to the I-15/2600 South interchange and the on/off ramps to/from I-15. This would provide an enhanced route for 800 West traffic and non-motorized traffic. The cost estimate for this improvement is \$_____. The funding source is the same as the I-15 Project, which was authorized by the Utah State Legislature.

Priority Project#4 - Bridge Connection over/under I-15 Connecting Residential on west side of I-15 and Woods Cross High School:

This priority project was identified in the EIS that was recently completed for I-15 between Salt Lake City to Farmington. As part of the EIS, UDOT completed a cost analysis for this Priority Connection and the 800 West overpass (Priority Project#3) and determined the 800 West Project to provide a better benefit. This connection is needed for economic and Regional Connectivity purposes. The biggest impediment is I-15 which bisects Woods Cross and disconnects active transportation or direct vehicular crossings for the Woods Cross High School. Woods Cross High School is a priority educational destination within Woods Cross This would provide an enhanced route for connectivity between the west side of I-15 and the High School. The cost estimate for this improvement is \$_____. It would be cost prohibitive to build a tunnel under I-15 and would also potentially generate public opposition. The funding sources for this would need to be Federal (ATIIP – Active Transportation Infrastructure Investment Program; CRP - Carbon reduction Program; CMAQ – Congestion Mitigation and Air Quality Improvement Program; RAISE – Rebuilding American Infrastructure with Sustainability and Equity; and STBG – Surface Transportation Block Grant Program) or State (TIF Active; TTIF First and Last Mile; UTN) funds.

These Priority Projects exclude other improvements that are already identified in the CIP and AT Plans. Several gaps in the active transportation network were included in the AT Plan and did not make the SB-195 Priority Projects List. Woods Cross City is also striving to enhance roadway

WOODS CROSS TRANSPORTATION MASTER PLAN

active transportation infrastructure by utilizing roadway typical sections that incorporate active transportation infrastructure like bike lanes, sidewalks and multi-use trails.

This information was presented to the public in an open house on January 21, 2026. No specific feedback was received from the public. The four priority Projects were also reviewed with UDOT in a February 2, 2026 meeting.

DRAFT

Figure 11: SB-195 Projects

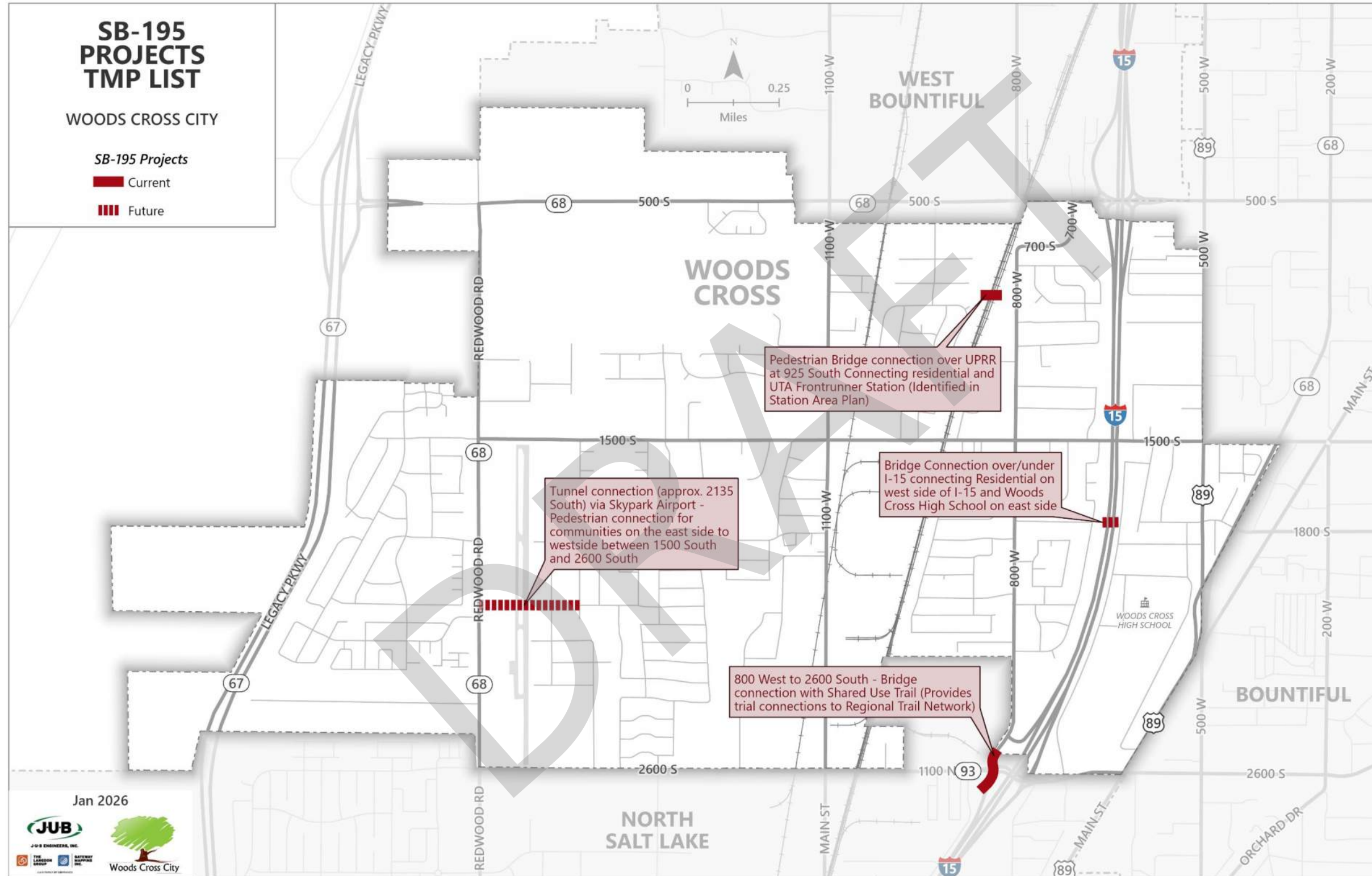

7. TRAFFIC CALMING

7.1 TRAFFIC CALMING

The Institute of Transportation Engineers (ITE) defines traffic calming as the combination of measures that reduce the negative effects of motor vehicle use, alter driver behavior, and improve conditions for non-motorized street users. Traffic calming consists of physical design and other measure put in place on existing roads to reduce vehicle speeds and improve safety for pedestrians and cyclists. For example, vertical deflections (speed humps, speed tables and raised intersections), horizontal shifts, and roadway narrowing are intended to reduce speed and enhance the street environment for non-motorists. Traffic calming measures can be implemented at an intersection, street, neighborhood, or at an area-wide level.

7.1.1 Installing Traffic Calming Measures

The decision to install Traffic Calming Measures (TCM) should be based on engineering merits as opposed to public input alone.

One or more TCMs can be implemented on a temporary basis subject to performance evaluation and neighborhood review. Before implementing a TCM on a permanent basis, a comparison of speed and volume should be performed to determine if the TCM meets expectations and produces the intended result.

ITE provides a list (see link below) of traffic calming measures along with descriptions, cost estimate, benefits and potential issues with a given TCM.

<https://www.ite.org/technical-resources/traffic-calming/traffic-calming-measures/>

8. TRAFFIC IMPACT STUDY GUIDELINES

8.1 TRAFFIC IMPACT STUDIES

Traffic Impact Studies (TIS) are necessary to identify, review and make recommendations for mitigation of the potential impacts a development may have on the roadway system. The City Engineer will determine the need for a Traffic Impact Study and the appropriate TIS level. When a Traffic Impact Study is required, prepare the study according to the appropriate TIS level as shown in **APPENDIX G: TRAFFIC IMPACT STUDY GUIDELINES**. The TIS shall, at a minimum, incorporate Woods Cross City standards as well as any applicable UDOT and federal standards or guidelines not superseded by City standards. Additional requirements may be added at the City Engineer's discretion.

APPENDIX A: TRAFFIC COUNTS AND ANALYSIS

DRAFT

LOCATION: 1100 W -- 1500 S
CITY/STATE: Woods Cross, UT

QC JOB #: 16760701
DATE: Wed, Sep 18 2024

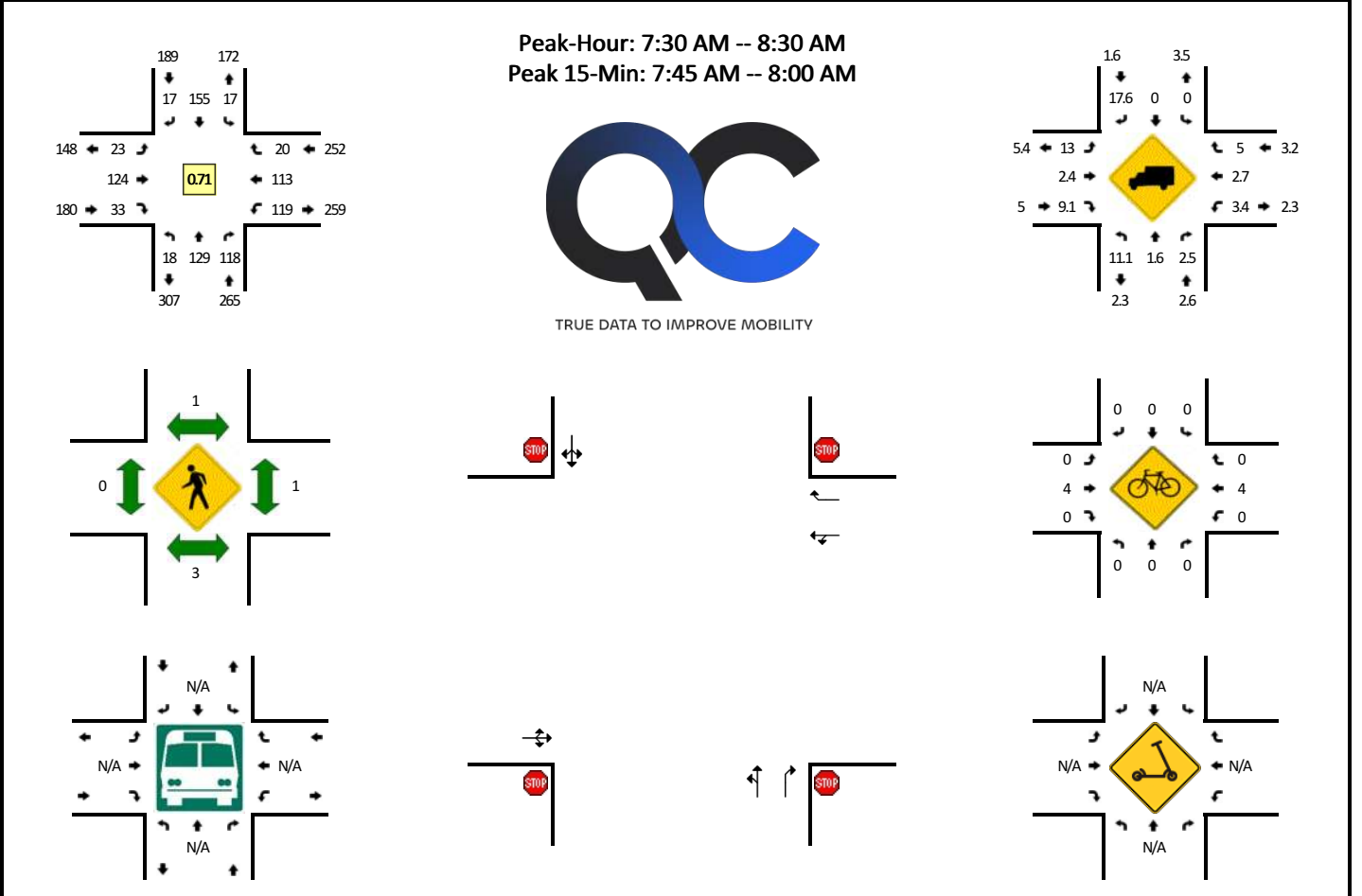

15-Min Count Period Beginning At	1100 W (Northbound)				1100 W (Southbound)				1500 S (Eastbound)				1500 S (Westbound)				Total	Hourly Totals
	Left	Thru	Right	U	Left	Thru	Right	U	Left	Thru	Right	U	Left	Thru	Right	U		
7:00 AM	2	9	14	0	4	18	3	0	4	16	6	0	10	11	4	0	101	
7:15 AM	4	11	13	0	4	29	7	0	3	13	5	0	16	25	4	0	134	
7:30 AM	6	23	21	0	1	49	4	0	6	23	18	0	44	32	7	0	234	
7:45 AM	8	48	45	0	3	71	9	0	6	34	7	0	45	33	5	0	314	783
8:00 AM	3	36	32	0	7	18	2	0	6	25	7	0	17	25	5	0	183	865
8:15 AM	1	22	20	0	6	17	2	0	5	42	1	0	13	23	3	0	155	886
8:30 AM	2	18	23	0	15	21	3	0	4	36	7	0	5	24	6	0	164	816
8:45 AM	3	22	26	0	4	26	8	0	5	47	2	0	13	34	9	0	199	701
Peak 15-Min Flowrates	Northbound				Southbound				Eastbound				Westbound				Total	
	Left	Thru	Right	U	Left	Thru	Right	U	Left	Thru	Right	U	Left	Thru	Right	U		
All Vehicles	32	192	180	0	12	284	36	0	24	136	28	0	180	132	20	0	1256	
Heavy Trucks	0	0	0		0	0	8		4	4	4		0	4	0		24	
Buses																		
Pedestrians		4				0				0				0			4	
Bicycles	0	0	0		0	0	0		0	0	0		0	4	0		4	
Scoters																		

Comments:

LOCATION: 1100 W -- 1500 S
CITY/STATE: Woods Cross, UT

QC JOB #: 16760702
DATE: Wed, Sep 18 2024

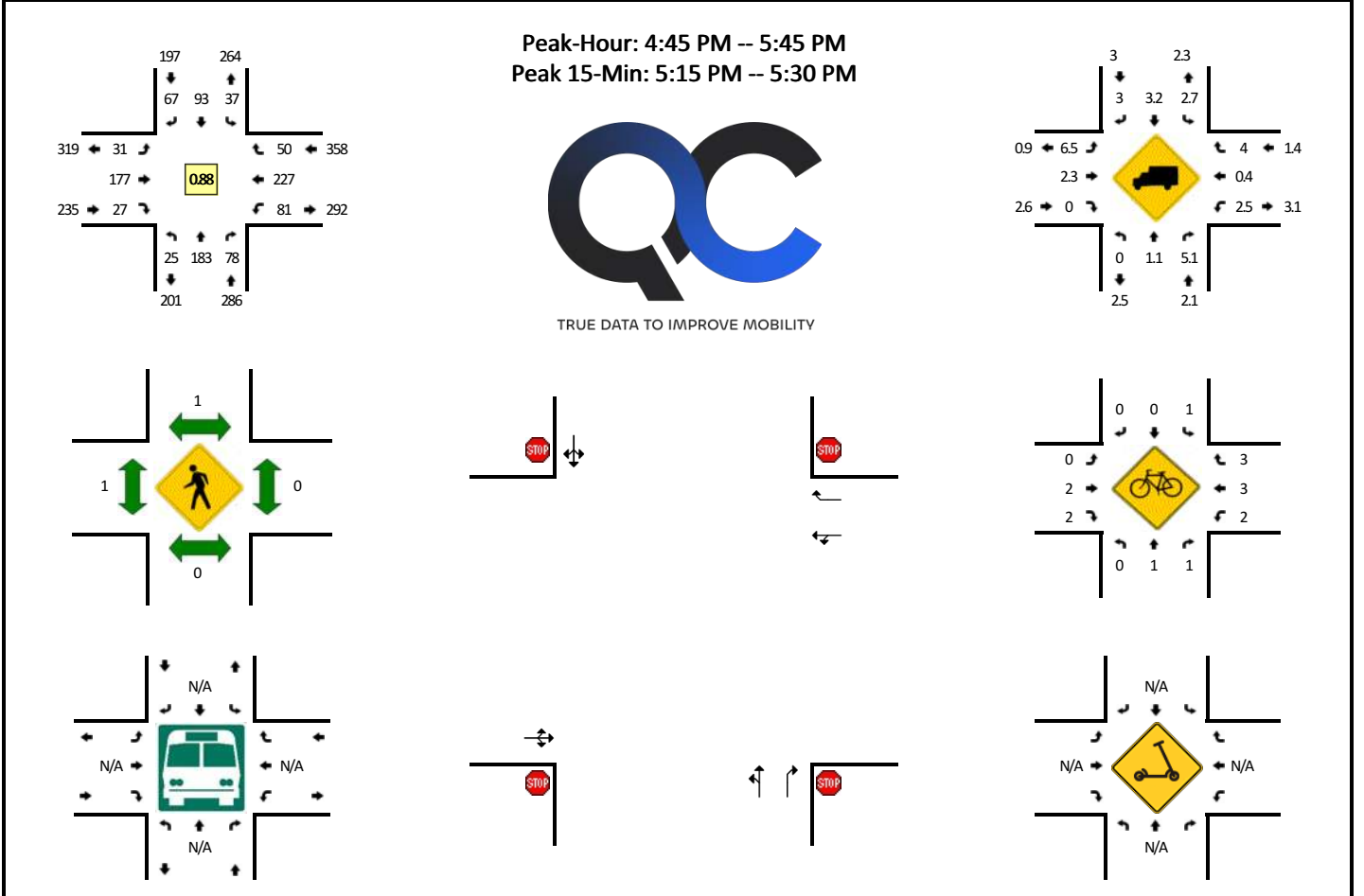

15-Min Count Period Beginning At	1100 W (Northbound)				1100 W (Southbound)				1500 S (Eastbound)				1500 S (Westbound)				Total	Hourly Totals
	Left	Thru	Right	U	Left	Thru	Right	U	Left	Thru	Right	U	Left	Thru	Right	U		
4:00 PM	3	38	16	0	4	25	12	0	9	66	6	0	12	40	8	0	239	
4:15 PM	6	37	18	0	8	17	7	0	13	38	2	0	19	44	8	0	217	
4:30 PM	10	32	16	0	7	20	15	0	13	45	4	0	13	31	15	0	221	
4:45 PM	3	46	16	0	6	19	21	0	8	44	7	0	13	48	15	0	246	923
5:00 PM	6	50	16	0	12	26	16	0	6	43	2	0	25	55	14	0	271	955
5:15 PM	6	49	24	0	7	23	8	0	11	53	7	0	23	80	13	0	304	1042
5:30 PM	10	38	22	0	12	25	22	0	6	37	11	0	20	44	8	0	255	1076
5:45 PM	6	17	15	0	5	31	9	0	8	42	11	0	14	49	11	0	218	1048

Peak 15-Min Flowrates	Northbound				Southbound				Eastbound				Westbound				Total
	Left	Thru	Right	U	Left	Thru	Right	U	Left	Thru	Right	U	Left	Thru	Right	U	
All Vehicles	24	196	96	0	28	92	32	0	44	212	28	0	92	320	52	0	1216
Heavy Trucks	0	4	4		0	4	0		4	8	0		0	0	0		24
Buses																	0
Pedestrians		0				0				0				0			0
Bicycles	0	0	0		0	0	0		0	8	0		0	0	4		12
Scoters																	

Comments:

LOCATION: Mountain View Blvd -- 1500S
CITY/STATE: Woods Cross, UT

QC JOB #: 16760703
DATE: Wed, Sep 18 2024

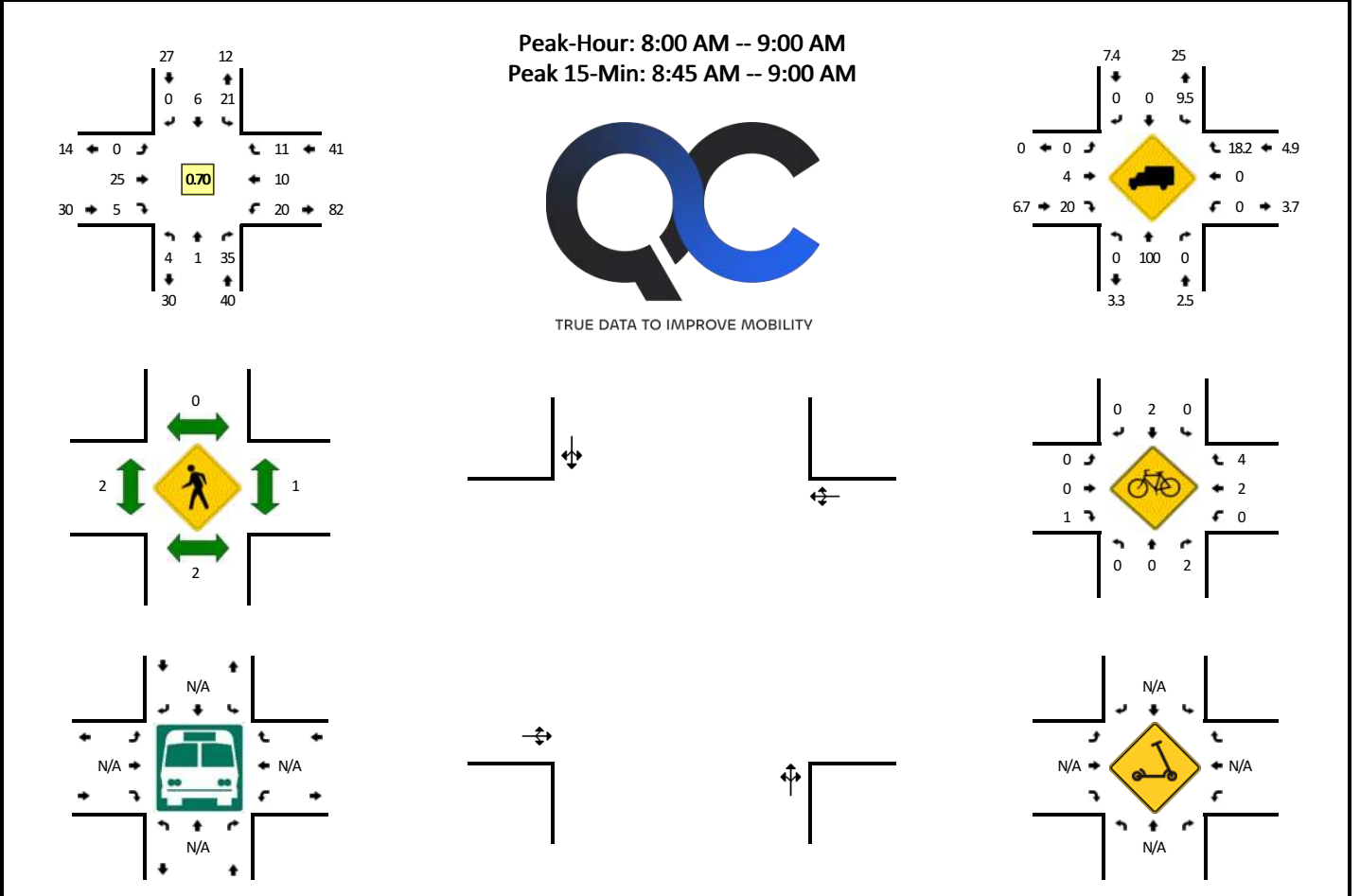

15-Min Count Period Beginning At	Mountain View Blvd (Northbound)				Mountain View Blvd (Southbound)				1500S (Eastbound)				1500S (Westbound)				Total	Hourly Totals
	Left	Thru	Right	U	Left	Thru	Right	U	Left	Thru	Right	U	Left	Thru	Right	U		
7:00 AM	0	0	1	0	2	0	0	0	0	3	0	0	2	1	1	0	10	
7:15 AM	0	0	6	0	9	0	0	0	0	6	0	0	3	4	2	0	30	
7:30 AM	0	0	4	0	12	0	1	0	0	9	0	0	2	2	2	0	32	
7:45 AM	0	0	9	0	13	0	1	0	0	8	2	0	4	1	2	0	40	112
8:00 AM	0	0	2	0	6	0	0	0	0	8	0	0	2	2	4	1	25	127
8:15 AM	1	0	6	0	7	1	0	0	0	5	2	0	2	2	4	0	30	127
8:30 AM	1	1	9	0	3	3	0	0	0	3	2	0	8	3	1	0	34	129
8:45 AM	2	0	18	0	5	2	0	0	0	9	1	0	7	3	2	0	49	138
Peak 15-Min Flowrates	Northbound				Southbound				Eastbound				Westbound				Total	
	Left	Thru	Right	U	Left	Thru	Right	U	Left	Thru	Right	U	Left	Thru	Right	U		
All Vehicles	8	0	72	0	20	8	0	0	0	36	4	0	28	12	8	0	196	
Heavy Trucks	0	0	0		4	0	0		0	0	0		0	0	8		12	
Buses																		
Pedestrians		4				0				4				0			8	
Bicycles	0	0	0		0	0	0		0	0	4		0	0	4		8	
Scooters																		

Comments:

LOCATION: Mountain View Blvd -- 1500S
CITY/STATE: Woods Cross, UT

QC JOB #: 16760704
DATE: Wed, Sep 18 2024

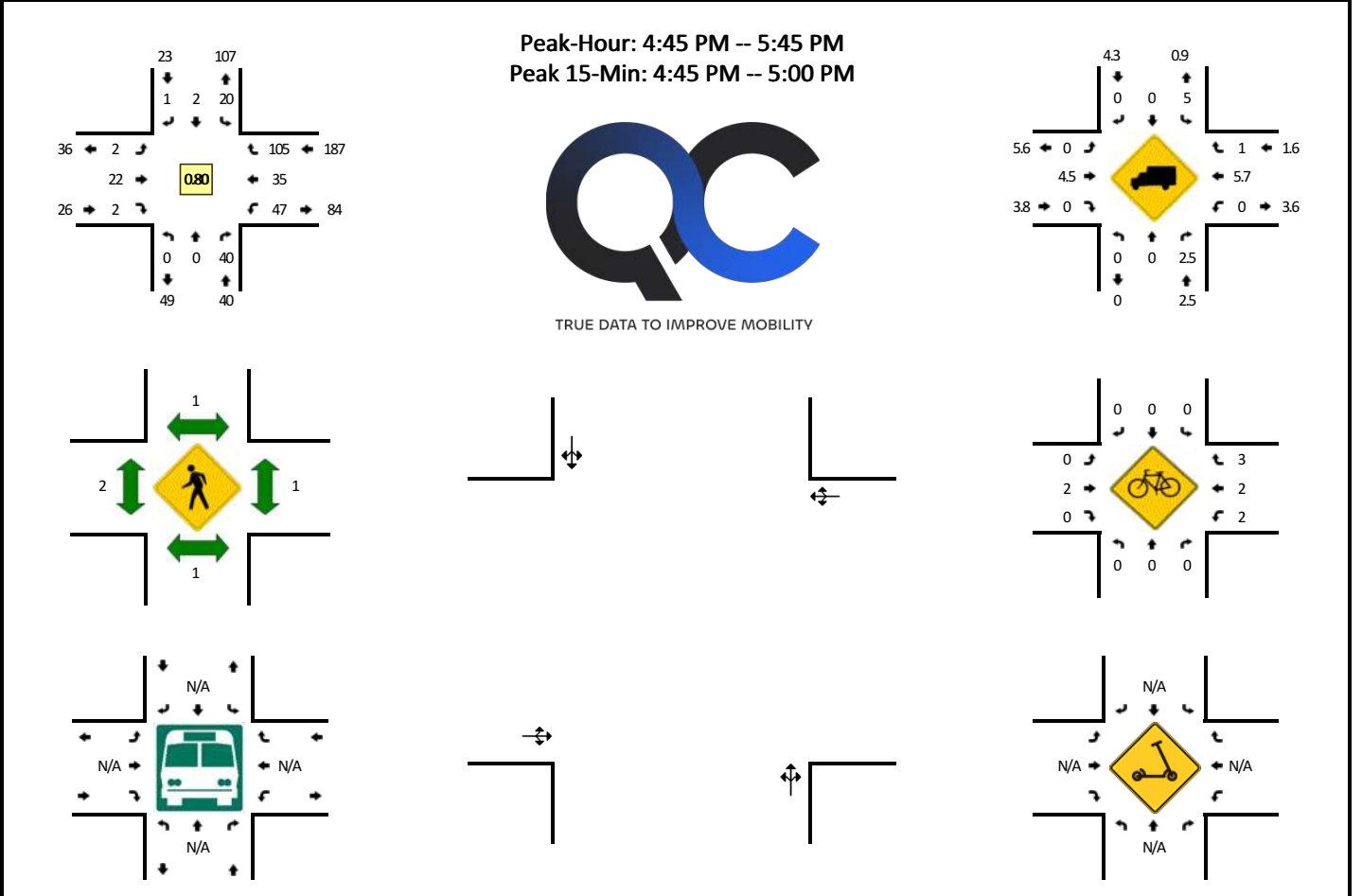

15-Min Count Period Beginning At	Mountain View Blvd (Northbound)				Mountain View Blvd (Southbound)				1500S (Eastbound)				1500S (Westbound)				Total	Hourly Totals
	Left	Thru	Right	U	Left	Thru	Right	U	Left	Thru	Right	U	Left	Thru	Right	U		
4:00 PM	1	0	13	0	5	0	0	1	0	3	0	0	9	6	7	0	45	
4:15 PM	1	0	8	0	9	0	1	2	0	9	0	0	9	2	5	0	46	
4:30 PM	1	0	15	0	6	0	0	2	0	1	2	0	9	5	10	0	51	
4:45 PM	0	0	13	0	7	1	0	0	1	8	1	0	9	8	37	1	86	228
5:00 PM	0	0	6	0	3	0	0	0	1	4	0	0	12	8	21	0	55	238
5:15 PM	0	0	11	0	2	1	1	0	0	4	0	0	9	9	31	1	69	261
5:30 PM	0	0	10	0	8	0	0	0	0	6	1	0	15	10	16	0	66	276
5:45 PM	0	2	12	0	28	2	0	1	0	5	0	0	8	7	16	0	81	271
Peak 15-Min Flowrates	Northbound				Southbound				Eastbound				Westbound				Total	
All Vehicles	0	0	52	0	28	4	0	0	4	32	4	0	36	32	148	4		344
Heavy Trucks	0	0	0		4	0	0		0	4	0		0	4	0		12	
Buses																		
Pedestrians		0				0				8				0			8	
Bicycles	0	0	0		0	0	0		0	8	0		0	0	8		16	
Scoters																		

Comments:

LOCATION: Mountain View Blvd -- 2260 S
CITY/STATE: Woods Cross, UT

QC JOB #: 16760705
DATE: Wed, Sep 18 2024

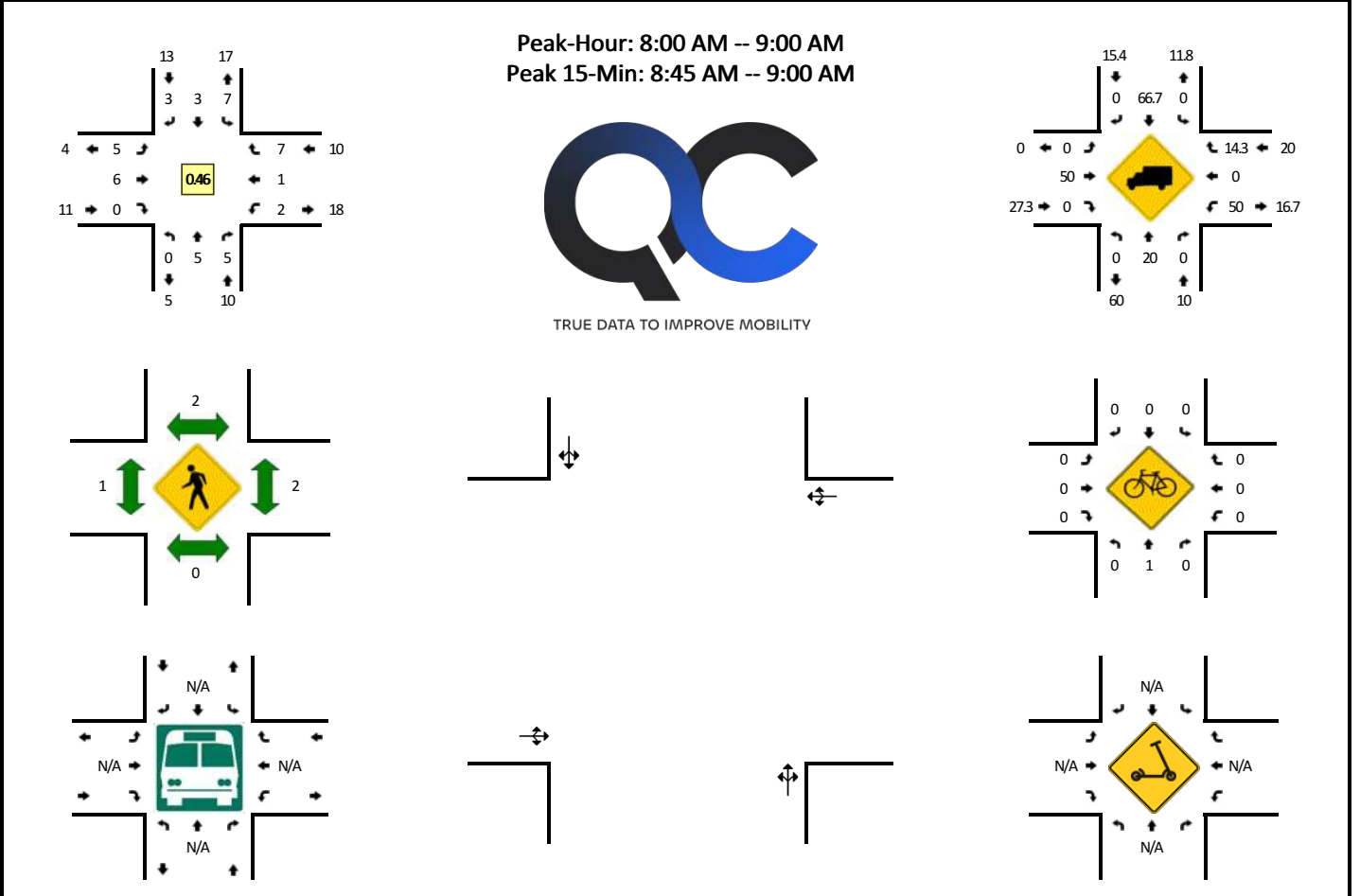

15-Min Count Period Beginning At	Mountain View Blvd (Northbound)				Mountain View Blvd (Southbound)				2260 S (Eastbound)				2260 S (Westbound)				Total	Hourly Totals
	Left	Thru	Right	U	Left	Thru	Right	U	Left	Thru	Right	U	Left	Thru	Right	U		
7:00 AM	0	1	1	0	0	0	1	0	0	1	0	0	0	0	2	0	6	
7:15 AM	0	0	1	0	3	0	0	0	1	2	0	0	0	0	1	0	8	
7:30 AM	0	2	0	0	1	0	0	0	0	2	0	0	0	0	0	0	5	
7:45 AM	0	2	1	0	2	1	0	0	1	0	0	0	0	0	0	0	7	26
8:00 AM	0	0	1	0	2	0	0	0	0	1	0	0	0	0	0	0	4	24
8:15 AM	0	0	1	0	0	0	0	0	0	1	0	0	1	1	1	0	5	21
8:30 AM	0	3	2	0	0	0	1	0	3	1	0	0	0	0	1	0	11	27
8:45 AM	0	2	1	0	5	3	2	0	2	3	0	0	1	0	5	0	24	44

Peak 15-Min Flowrates	Northbound				Southbound				Eastbound				Westbound				Total
	Left	Thru	Right	U	Left	Thru	Right	U	Left	Thru	Right	U	Left	Thru	Right	U	
All Vehicles	0	8	4	0	20	12	8	0	8	12	0	0	4	0	20	0	96
Heavy Trucks	0	4	0		0	8	0		0	12	0		4	0	0		28
Buses																	
Pedestrians		0				8				0				0			8
Bicycles	0	0	0		0	0	0		0	0	0		0	0	0		0
Scoters																	

Comments:

LOCATION: Mountain View Blvd -- 2260 S
CITY/STATE: Woods Cross, UT

QC JOB #: 16760706
DATE: Wed, Sep 18 2024

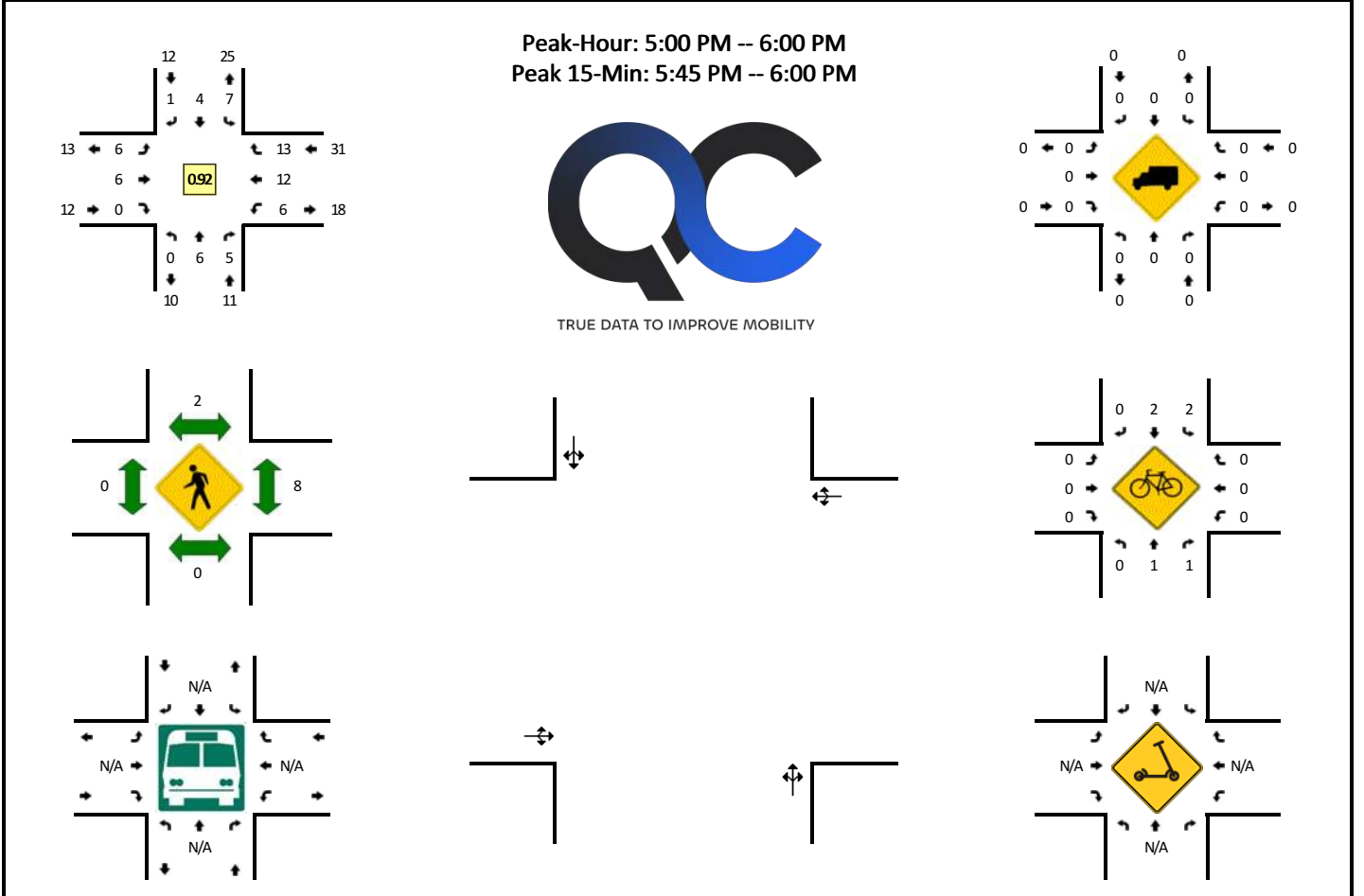

15-Min Count Period Beginning At	Mountain View Blvd (Northbound)				Mountain View Blvd (Southbound)				2260 S (Eastbound)				2260 S (Westbound)				Total	Hourly Totals
	Left	Thru	Right	U	Left	Thru	Right	U	Left	Thru	Right	U	Left	Thru	Right	U		
4:00 PM	1	1	0	0	2	1	1	0	2	2	0	0	1	1	2	0	14	
4:15 PM	1	1	0	0	2	1	1	0	3	2	0	0	2	2	4	0	19	
4:30 PM	0	1	0	0	0	2	1	0	1	2	0	0	3	3	2	0	15	
4:45 PM	0	3	2	0	0	3	0	0	1	2	0	0	2	0	1	0	14	62
5:00 PM	0	0	3	0	2	1	0	0	3	1	0	0	2	3	2	0	17	65
5:15 PM	0	2	0	0	1	0	1	0	1	4	0	0	1	3	4	0	17	63
5:30 PM	0	2	0	0	2	1	0	0	1	1	0	0	2	3	2	0	14	62
5:45 PM	0	2	2	0	2	2	0	0	1	0	0	0	1	3	5	0	18	66

Peak 15-Min Flowrates	Northbound				Southbound				Eastbound				Westbound				Total
	Left	Thru	Right	U	Left	Thru	Right	U	Left	Thru	Right	U	Left	Thru	Right	U	
All Vehicles	0	8	8	0	8	8	0	0	4	0	0	0	4	12	20	0	72
Heavy Trucks	0	0	0	0	0	0	0	0	0	0	0	0	0	0	0	0	0
Buses																	
Pedestrians		0				4				0				0			4
Bicycles	0	0	0		0	0	0		0	0	0		0	0	0		0
Scoters																	

Comments:

LOCATION: 1425 W -- 1900 S
CITY/STATE: Woods Cross, UT

QC JOB #: 16760707
DATE: Wed, Sep 18 2024

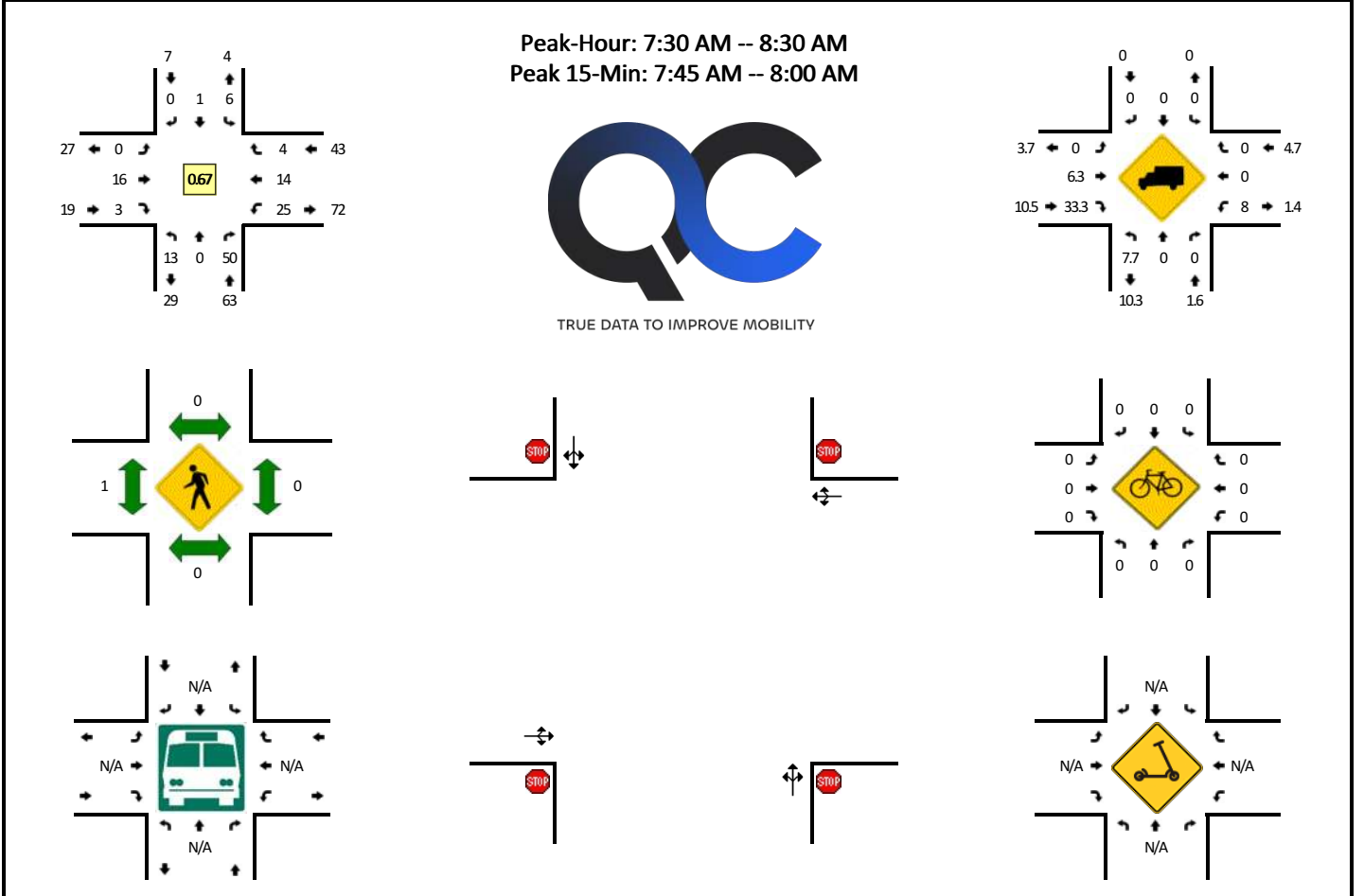

15-Min Count Period Beginning At	1425 W (Northbound)				1425 W (Southbound)				1900 S (Eastbound)				1900 S (Westbound)				Total	Hourly Totals
	Left	Thru	Right	U	Left	Thru	Right	U	Left	Thru	Right	U	Left	Thru	Right	U		
7:00 AM	1	0	7	0	1	0	0	0	0	8	0	0	3	2	0	0	22	
7:15 AM	2	0	8	0	1	0	0	0	0	5	0	0	6	2	0	0	24	
7:30 AM	3	0	13	0	2	0	0	0	0	4	1	0	4	2	0	0	29	
7:45 AM	5	0	18	0	2	0	0	0	0	6	0	0	6	9	3	0	49	124
8:00 AM	3	0	6	0	0	1	0	0	0	2	0	0	9	2	1	0	24	126
8:15 AM	2	0	13	0	2	0	0	0	0	4	2	0	6	1	0	0	30	132
8:30 AM	2	0	8	0	1	2	0	0	0	7	0	0	1	2	0	0	23	126
8:45 AM	4	0	25	0	0	0	0	0	0	8	1	0	5	4	0	0	47	124
Peak 15-Min Flowrates	Northbound				Southbound				Eastbound				Westbound				Total	
	Left	Thru	Right	U	Left	Thru	Right	U	Left	Thru	Right	U	Left	Thru	Right	U		
All Vehicles	20	0	72	0	8	0	0	0	0	24	0	0	24	36	12	0	196	
Heavy Trucks	0	0	0		0	0	0		0	0	0		0	0	0		0	
Buses																	0	
Pedestrians		0				0				0				0			0	
Bicycles	0	0	0		0	0	0		0	0	0		0	0	0		0	
Scoters																	0	

Comments:

LOCATION: 1425 W -- 1900 S
CITY/STATE: Woods Cross, UT

QC JOB #: 16760708
DATE: Wed, Sep 18 2024

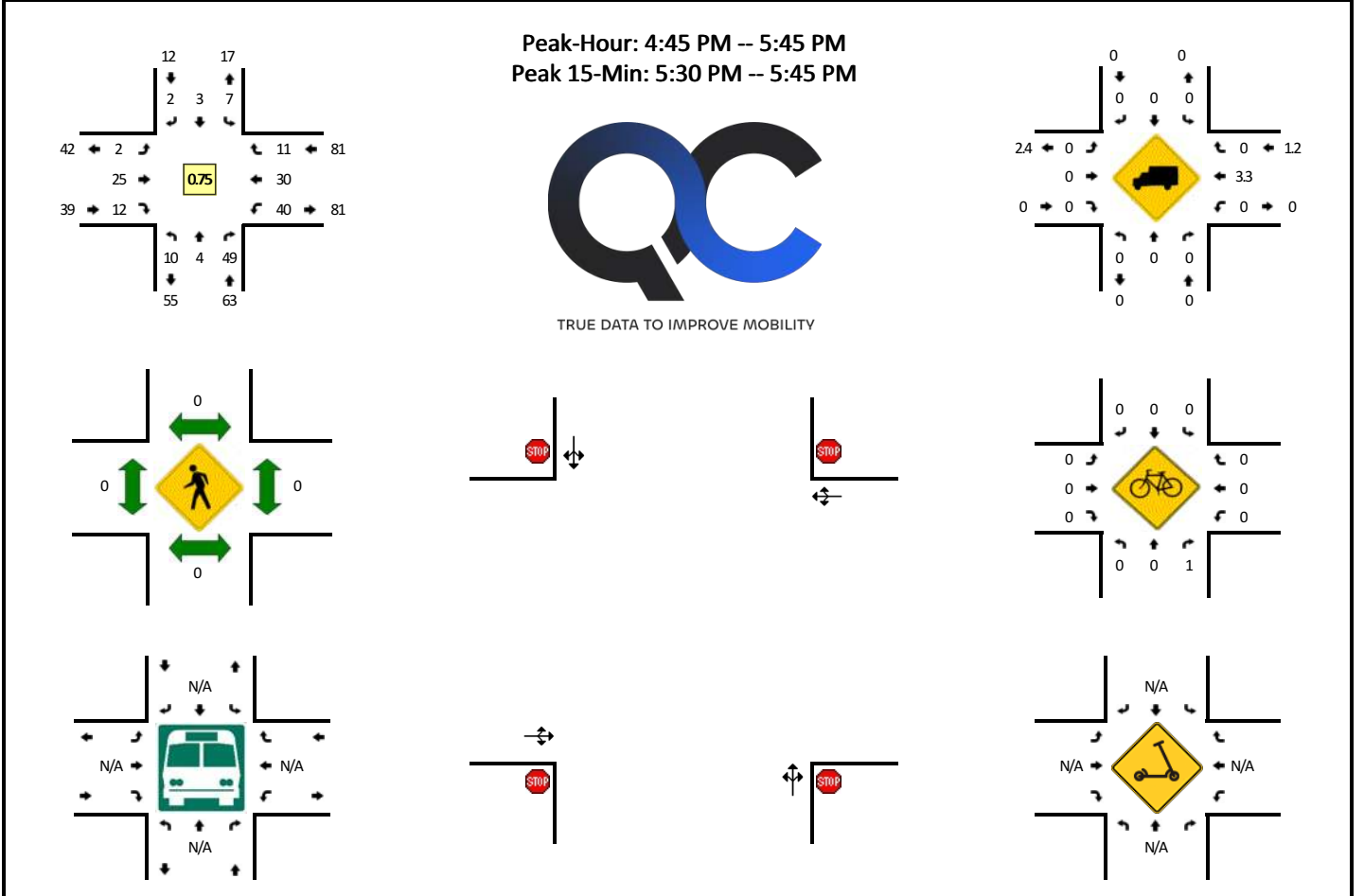

15-Min Count Period Beginning At	1425 W (Northbound)				1425 W (Southbound)				1900 S (Eastbound)				1900 S (Westbound)				Total	Hourly Totals
	Left	Thru	Right	U	Left	Thru	Right	U	Left	Thru	Right	U	Left	Thru	Right	U		
4:00 PM	1	1	6	0	1	1	1	0	0	8	3	0	8	11	2	0	43	
4:15 PM	3	2	10	0	0	1	1	0	0	9	2	0	13	7	1	0	49	
4:30 PM	0	0	10	0	2	0	0	0	0	6	1	0	10	8	1	0	38	
4:45 PM	0	0	16	0	2	0	0	0	0	5	2	0	8	8	2	0	43	173
5:00 PM	2	1	10	0	1	0	0	0	0	7	3	0	8	5	3	0	40	170
5:15 PM	2	2	12	0	1	0	1	0	2	5	1	0	10	9	2	0	47	168
5:30 PM	6	1	11	0	3	3	1	0	0	8	6	0	14	8	4	0	65	195
5:45 PM	0	3	7	0	0	1	0	0	0	8	0	0	9	8	2	0	38	190
Peak 15-Min Flowrates	Northbound				Southbound				Eastbound				Westbound				Total	
	Left	Thru	Right	U	Left	Thru	Right	U	Left	Thru	Right	U	Left	Thru	Right	U		
All Vehicles	24	4	44	0	12	12	4	0	0	32	24	0	56	32	16	0	260	
Heavy Trucks	0	0	0		0	0	0		0	0	0		0	0	0		0	
Buses																		
Pedestrians		0				0				0				0			0	
Bicycles	0	0	0		0	0	0		0	0	0		0	0	0		0	
Scoters																		

Comments:

LOCATION: 800W -- 1100S
CITY/STATE: Woods Cross, UT

QC JOB #: 16760709
DATE: Wed, Sep 18 2024

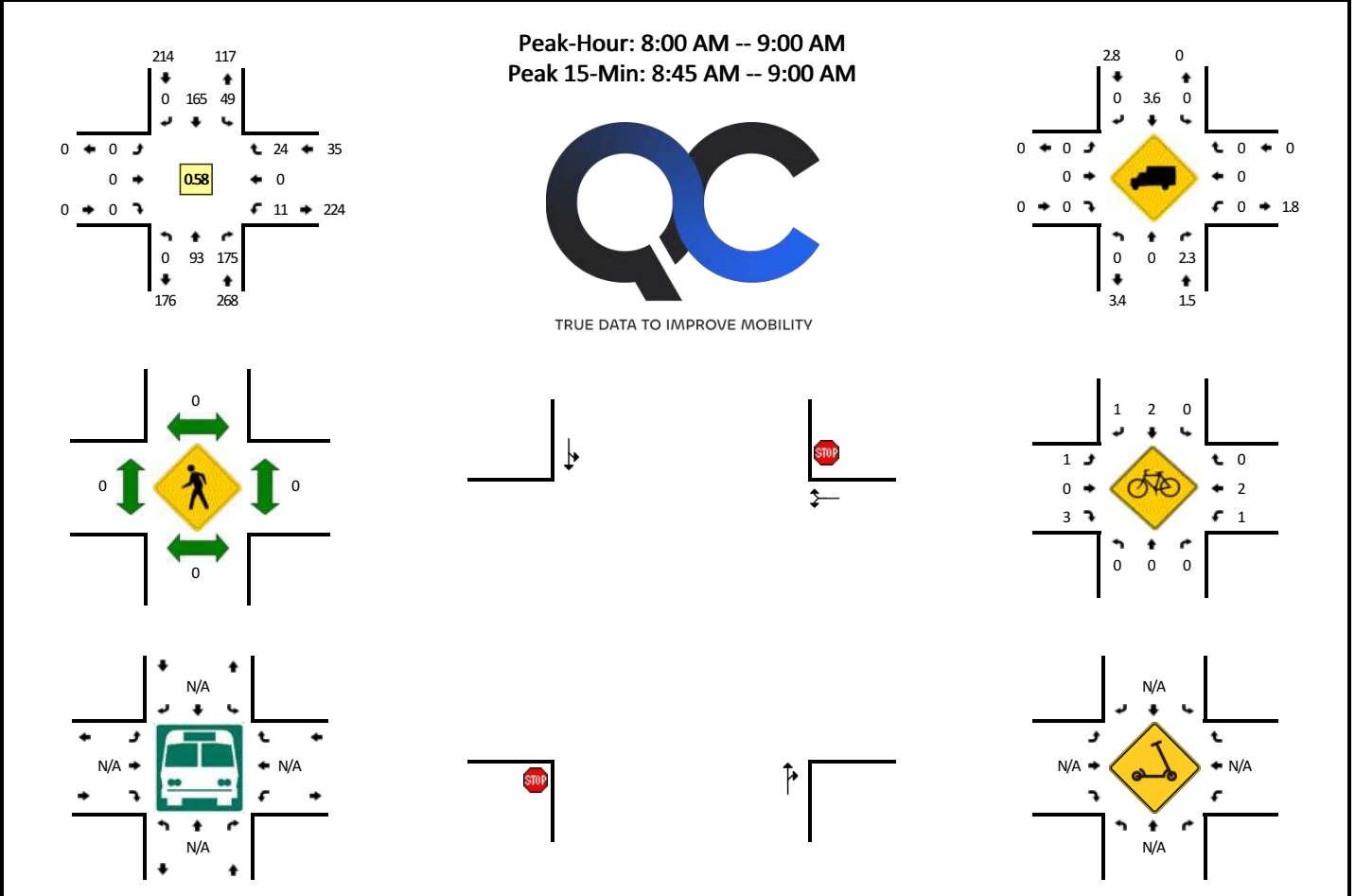

15-Min Count Period Beginning At	800W (Northbound)				800W (Southbound)				1100S (Eastbound)				1100S (Westbound)				Total	Hourly Totals
	Left	Thru	Right	U	Left	Thru	Right	U	Left	Thru	Right	U	Left	Thru	Right	U		
7:00 AM	0	24	1	0	0	15	0	0	0	0	0	0	0	0	3	0	43	
7:15 AM	0	19	0	0	3	19	0	0	0	0	0	0	2	0	0	0	43	
7:30 AM	0	32	2	0	5	16	0	0	0	0	0	0	2	0	4	0	61	
7:45 AM	0	31	4	0	7	21	0	0	0	0	0	0	1	0	0	0	64	211
8:00 AM	0	28	9	0	6	30	0	0	0	0	0	0	0	0	4	0	77	245
8:15 AM	0	22	15	0	10	13	0	0	0	0	0	0	1	0	2	0	63	265
8:30 AM	0	15	83	0	19	36	0	0	0	0	0	0	0	0	2	0	155	359
8:45 AM	0	28	68	0	14	86	0	0	0	0	0	0	10	0	16	0	222	517
Peak 15-Min Flowrates	Northbound				Southbound				Eastbound				Westbound				Total	
	Left	Thru	Right	U	Left	Thru	Right	U	Left	Thru	Right	U	Left	Thru	Right	U		
All Vehicles	0	112	272	0	56	344	0	0	0	0	0	0	40	0	64	0	888	
Heavy Trucks	0	0	0		0	4	0		0	0	0		0	0	0		4	
Buses																	0	
Pedestrians		0				0				0				0			0	
Bicycles	0	0	0		0	0	4		4	0	4		4	8	0		24	
Scooters																		

Comments:

LOCATION: 800W -- 1100S
CITY/STATE: Woods Cross, UT

QC JOB #: 16760710
DATE: Wed, Sep 18 2024

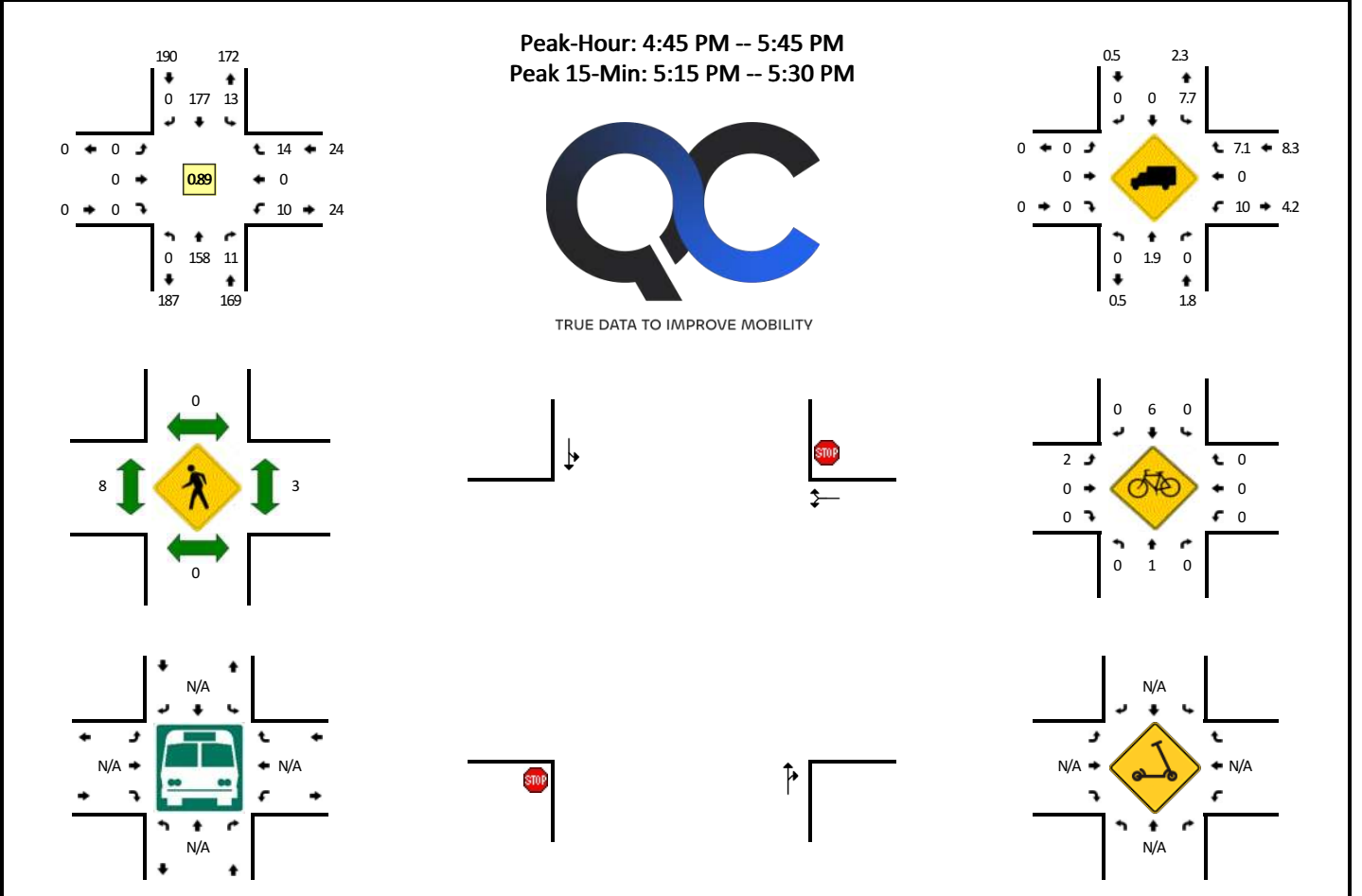

15-Min Count Period Beginning At	800W (Northbound)				800W (Southbound)				1100S (Eastbound)				1100S (Westbound)				Total	Hourly Totals
	Left	Thru	Right	U	Left	Thru	Right	U	Left	Thru	Right	U	Left	Thru	Right	U		
4:00 PM	0	34	7	0	3	26	0	0	0	0	0	0	9	0	10	0	89	
4:15 PM	0	34	1	0	2	33	0	0	0	0	0	0	3	0	2	0	75	
4:30 PM	0	33	5	0	1	39	0	0	0	0	0	0	2	0	9	0	89	
4:45 PM	0	25	3	0	4	48	0	0	0	0	0	0	1	0	2	0	83	336
5:00 PM	0	41	2	0	3	44	0	0	0	0	0	0	5	0	2	0	97	344
5:15 PM	0	48	4	0	3	47	0	0	0	0	0	0	3	0	3	0	108	377
5:30 PM	0	44	2	0	3	38	0	0	0	0	0	0	1	0	7	0	95	383
5:45 PM	0	36	1	0	1	38	0	0	0	0	0	0	4	0	2	0	82	382
Peak 15-Min Flowrates	Northbound				Southbound				Eastbound				Westbound				Total	
	Left	Thru	Right	U	Left	Thru	Right	U	Left	Thru	Right	U	Left	Thru	Right	U		
All Vehicles	0	192	16	0	12	188	0	0	0	0	0	0	12	0	12	0	432	
Heavy Trucks	0	0	0		0	0	0		0	0	0		0	0	0		0	
Buses																		
Pedestrians		0				0				4				0			4	
Bicycles	0	0	0		0	12	0		8	0	0		0	0	0		20	
Scooters																		

Comments:

LOCATION: 1450W -- 1500S
CITY/STATE: Woods Cross, UT

QC JOB #: 16760711
DATE: Wed, Sep 18 2024

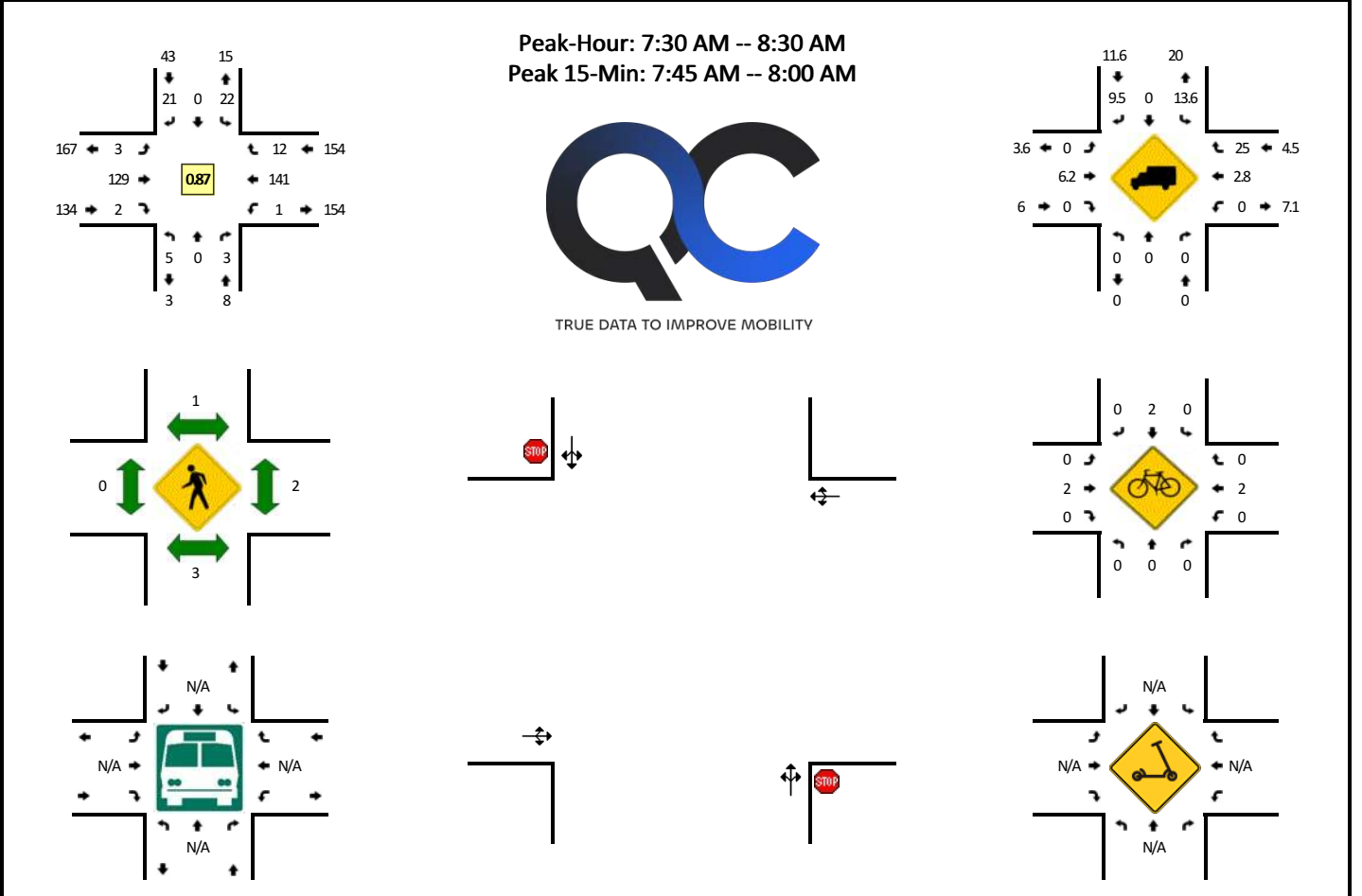

15-Min Count Period Beginning At	1450W (Northbound)				1450W (Southbound)				1500S (Eastbound)				1500S (Westbound)				Total	Hourly Totals
	Left	Thru	Right	U	Left	Thru	Right	U	Left	Thru	Right	U	Left	Thru	Right	U		
7:00 AM	1	0	0	0	4	0	1	0	0	21	0	0	0	19	1	0	47	
7:15 AM	0	0	0	0	5	0	7	0	2	10	0	0	0	30	1	0	55	
7:30 AM	0	0	1	0	7	0	9	0	0	29	0	0	0	47	2	0	95	
7:45 AM	3	0	0	0	4	0	5	0	2	34	2	0	0	45	2	0	97	294
8:00 AM	1	0	2	0	6	0	1	0	1	31	0	0	1	28	3	0	74	321
8:15 AM	1	0	0	0	5	0	6	0	0	35	0	0	0	21	5	0	73	339
8:30 AM	1	0	2	0	6	0	1	0	1	33	1	0	0	33	0	0	78	322
8:45 AM	2	0	1	0	2	0	1	0	0	47	0	0	2	37	4	0	96	321
Peak 15-Min Flowrates	Northbound				Southbound				Eastbound				Westbound				Total	
	Left	Thru	Right	U	Left	Thru	Right	U	Left	Thru	Right	U	Left	Thru	Right	U		
All Vehicles	12	0	0	0	16	0	20	0	8	136	8	0	0	180	8	0	388	
Heavy Trucks	0	0	0		0	0	0		0	8	0		0	4	0		12	
Buses																		
Pedestrians		0				4				0				4			8	
Bicycles	0	0	0		0	0	0		0	0	0		0	0	0		0	
Scooters																		

Comments:

LOCATION: 1450W -- 1500S
CITY/STATE: Woods Cross, UT

QC JOB #: 16760712
DATE: Wed, Sep 18 2024

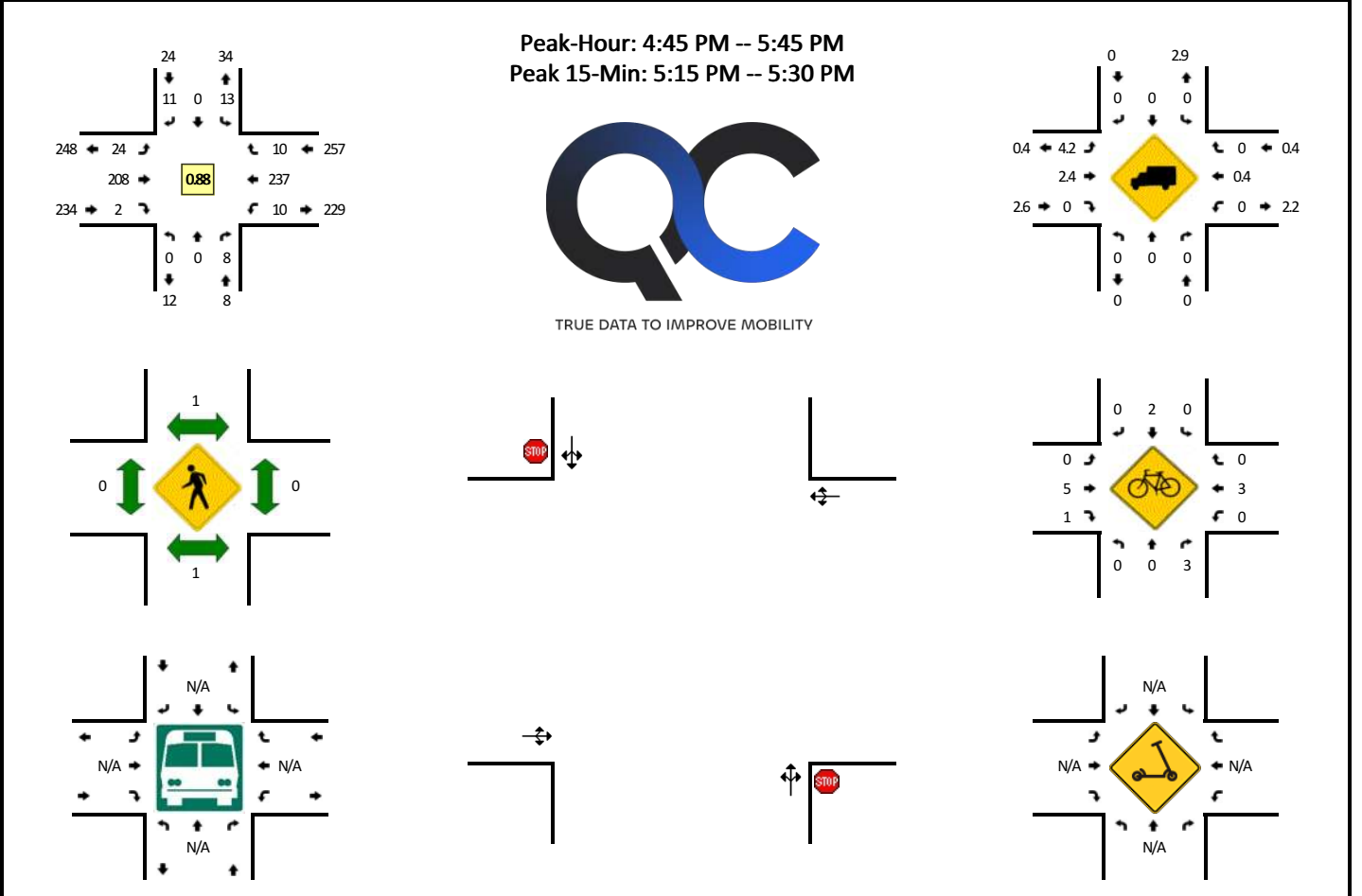

15-Min Count Period Beginning At	1450W (Northbound)				1450W (Southbound)				1500S (Eastbound)				1500S (Westbound)				Total	Hourly Totals
	Left	Thru	Right	U	Left	Thru	Right	U	Left	Thru	Right	U	Left	Thru	Right	U		
4:00 PM	0	0	2	0	5	0	1	0	5	66	0	0	1	41	3	0	124	
4:15 PM	0	0	1	0	4	0	3	0	3	49	1	0	0	45	3	0	109	
4:30 PM	1	0	1	0	4	0	8	0	5	56	0	0	2	36	3	0	116	
4:45 PM	0	0	1	0	4	0	4	0	5	48	1	0	4	55	4	0	126	475
5:00 PM	0	0	1	0	5	0	5	0	10	42	1	0	3	58	0	0	125	476
5:15 PM	0	0	5	0	3	0	1	0	5	63	0	0	0	69	2	0	148	515
5:30 PM	0	0	1	0	1	0	1	0	4	55	0	0	3	55	4	0	124	523
5:45 PM	0	0	0	0	2	0	5	0	5	53	0	0	0	45	7	0	117	514

Peak 15-Min Flowrates	Northbound				Southbound				Eastbound				Westbound				Total
	Left	Thru	Right	U	Left	Thru	Right	U	Left	Thru	Right	U	Left	Thru	Right	U	
All Vehicles	0	0	20	0	12	0	4	0	20	252	0	0	0	276	8	0	592
Heavy Trucks	0	0	0		0	0	0		0	12	0		0	0	0		12
Buses																	0
Pedestrians		0				0				0				0			0
Bicycles	0	0	0		0	0	0		0	0	0		0	0	0		0
Scoters																	0

Comments:

LOCATION: 1600 W -- 1500 S
CITY/STATE: Woods Cross, UT

QC JOB #: 16760713
DATE: Wed, Sep 18 2024

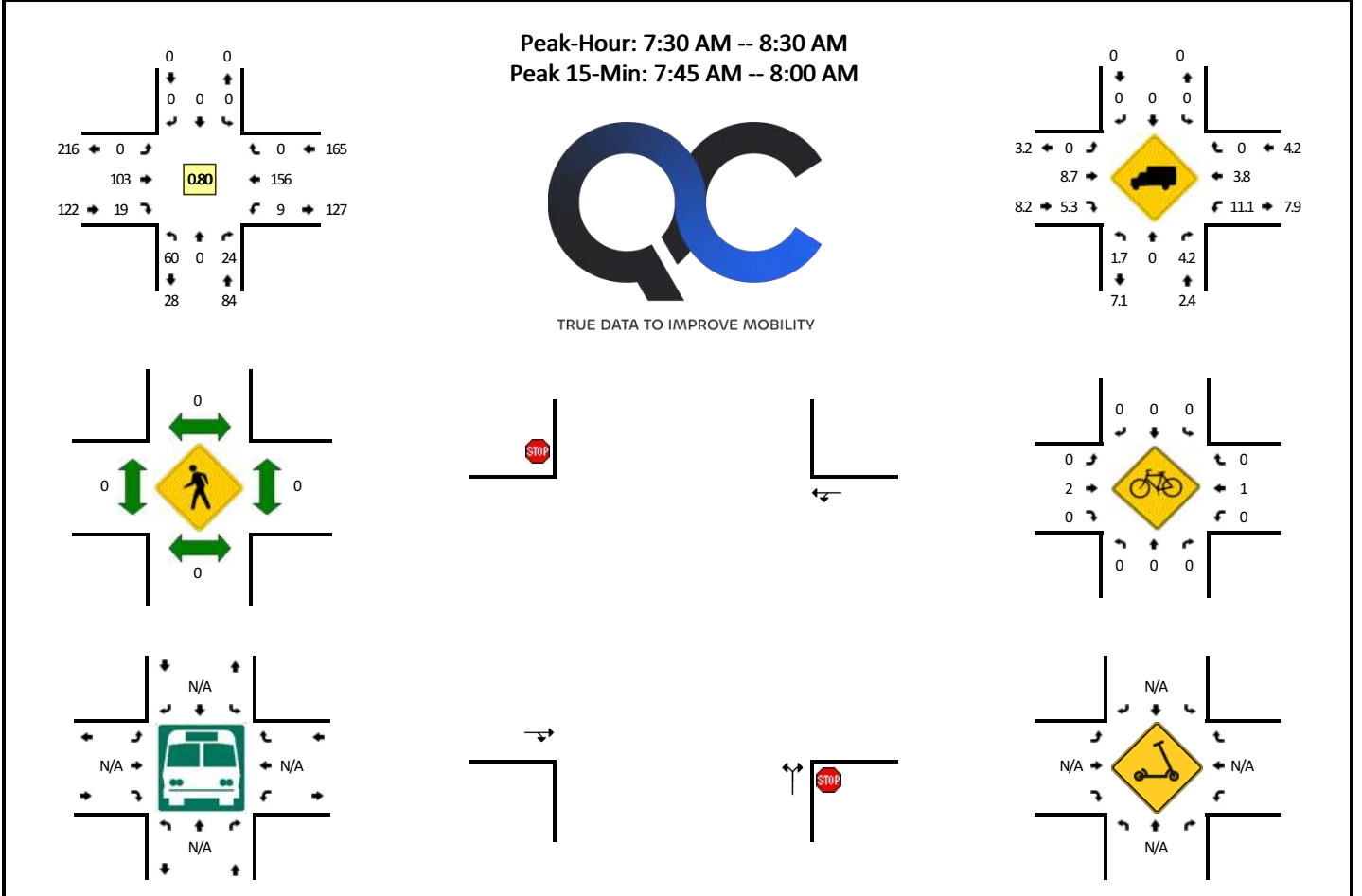

15-Min Count Period Beginning At	1600 W (Northbound)				1600 W (Southbound)				1500 S (Eastbound)				1500 S (Westbound)				Total	Hourly Totals
	Left	Thru	Right	U	Left	Thru	Right	U	Left	Thru	Right	U	Left	Thru	Right	U		
7:00 AM	9	0	4	0	0	0	0	0	0	12	3	0	1	23	0	0	52	
7:15 AM	10	0	1	0	0	0	0	0	0	11	0	0	1	34	0	0	57	
7:30 AM	16	0	5	0	0	0	0	0	0	17	4	0	2	53	0	0	97	
7:45 AM	23	0	7	0	0	0	0	0	0	32	5	0	3	46	0	0	116	322
8:00 AM	11	0	5	0	0	0	0	0	0	26	6	0	3	32	0	0	83	353
8:15 AM	10	0	7	0	0	0	0	0	0	28	4	0	1	25	0	0	75	371
8:30 AM	12	0	6	0	0	0	0	0	0	24	3	0	2	36	0	0	83	357
8:45 AM	12	0	2	0	0	0	0	0	0	46	5	0	2	34	0	0	101	342
Peak 15-Min Flowrates	Northbound				Southbound				Eastbound				Westbound				Total	
	Left	Thru	Right	U	Left	Thru	Right	U	Left	Thru	Right	U	Left	Thru	Right	U		
All Vehicles	92	0	28	0	0	0	0	0	0	128	20	0	12	184	0	0	464	
Heavy Trucks	0	0	0		0	0	0		0	8	0		0	4	0		12	
Buses																		
Pedestrians		0				0				0				0			0	
Bicycles	0	0	0		0	0	0		0	0	0		0	0	0		0	
Scoters																		

Comments:

LOCATION: 1600 W -- 1500 S
CITY/STATE: Woods Cross, UT

QC JOB #: 16760714
DATE: Wed, Sep 18 2024

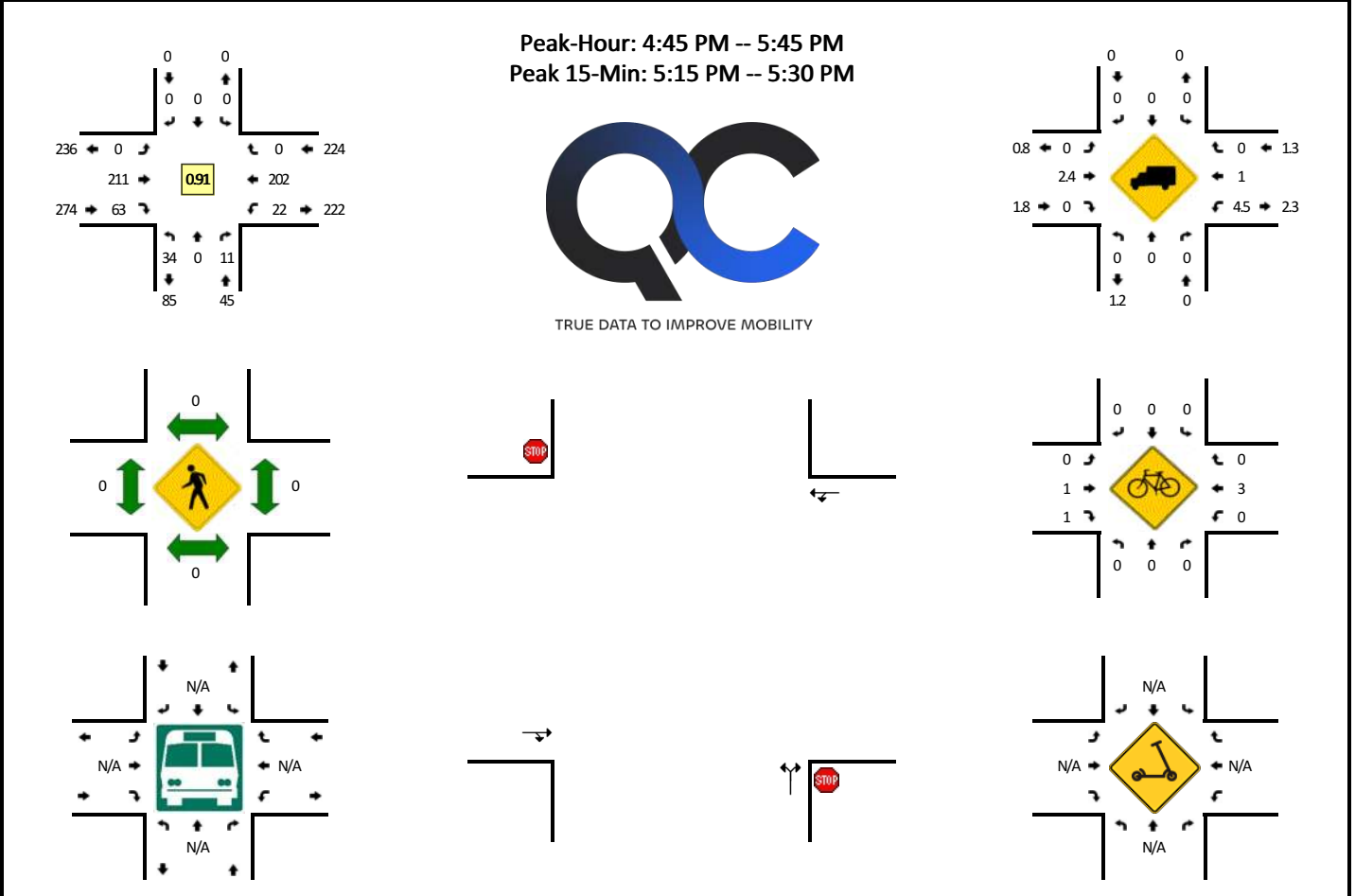

15-Min Count Period Beginning At	1600 W (Northbound)				1600 W (Southbound)				1500 S (Eastbound)				1500 S (Westbound)				Total	Hourly Totals
	Left	Thru	Right	U	Left	Thru	Right	U	Left	Thru	Right	U	Left	Thru	Right	U		
4:00 PM	10	0	7	0	0	0	0	0	0	69	14	0	7	28	0	0	135	
4:15 PM	11	0	2	0	0	0	0	0	0	39	19	0	1	49	0	0	121	
4:30 PM	11	0	5	0	0	0	0	0	0	55	13	0	6	34	0	0	124	
4:45 PM	8	0	3	0	0	0	0	0	0	45	15	0	9	45	0	0	125	505
5:00 PM	10	0	5	0	0	0	0	0	0	48	12	0	5	52	0	0	132	502
5:15 PM	9	0	0	0	0	0	0	0	0	62	16	0	3	60	0	0	150	531
5:30 PM	7	0	3	0	0	0	0	0	0	56	20	0	5	45	0	0	136	543
5:45 PM	4	0	5	0	0	0	0	0	0	52	11	0	7	40	0	0	119	537
Peak 15-Min Flowrates	Northbound				Southbound				Eastbound				Westbound				Total	
	Left	Thru	Right	U	Left	Thru	Right	U	Left	Thru	Right	U	Left	Thru	Right	U		
All Vehicles	36	0	0	0	0	0	0	0	0	248	64	0	12	240	0	0	600	
Heavy Trucks	0	0	0	0	0	0	0	0	0	8	0	0	0	4	0	0	12	
Buses																		
Pedestrians		0				0				0				0			0	
Bicycles	0	0	0		0	0	0			0	0	0	0	4	0		4	
Scoters																		

Comments:

LOCATION: 1955 W -- 1950
CITY/STATE: Woods Cross, UT

QC JOB #: 16760715
DATE: Wed, Sep 18 2024

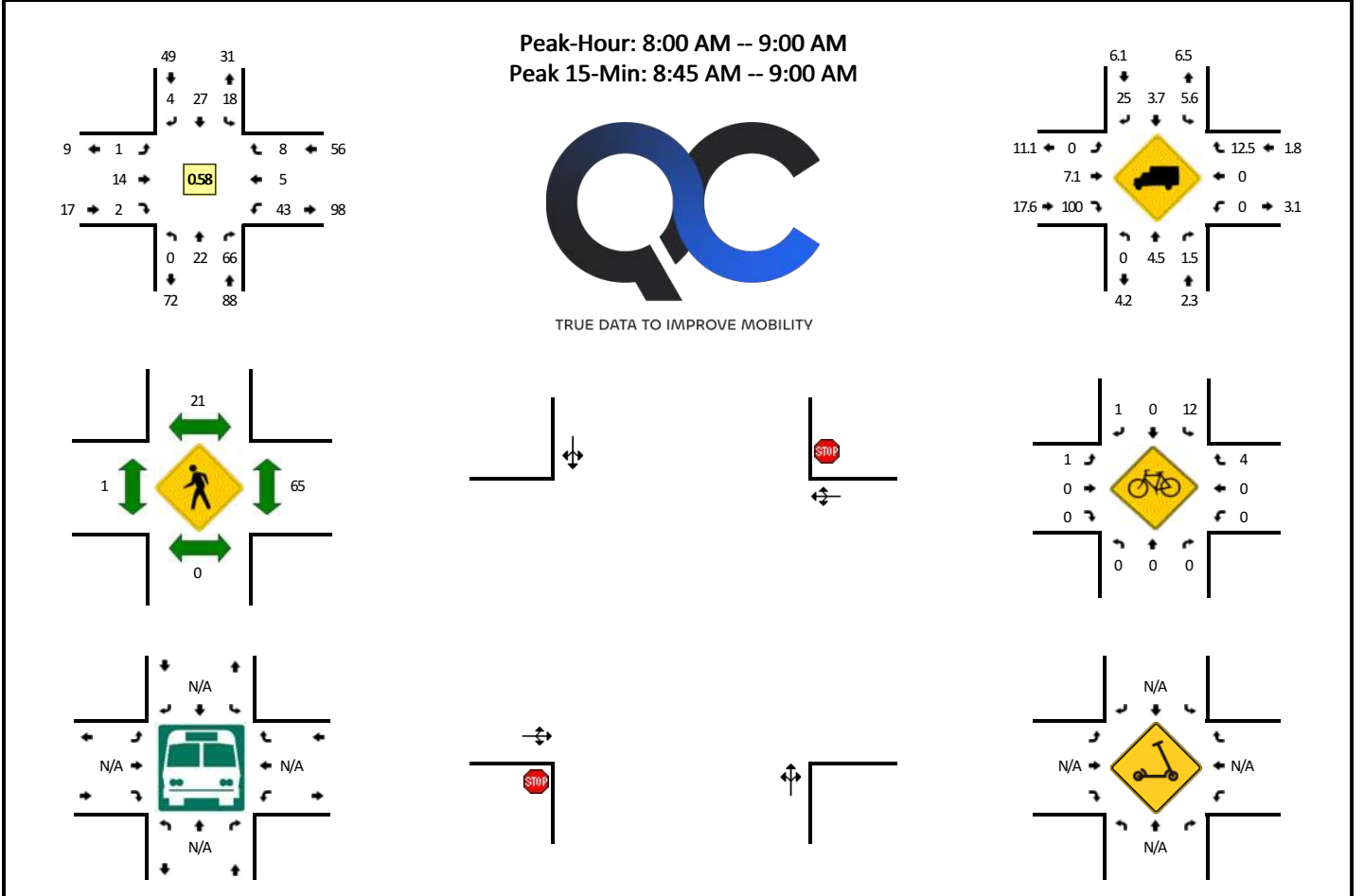

15-Min Count Period Beginning At	1955 W (Northbound)				1955 W (Southbound)				1950 (Eastbound)				1950 (Westbound)				Total	Hourly Totals
	Left	Thru	Right	U	Left	Thru	Right	U	Left	Thru	Right	U	Left	Thru	Right	U		
7:00 AM	0	0	4	0	4	0	0	0	0	2	0	0	1	1	1	0	13	
7:15 AM	0	0	0	0	5	1	1	0	0	1	0	0	1	0	1	0	10	
7:30 AM	0	0	4	0	5	0	0	0	0	4	0	0	6	4	1	0	24	
7:45 AM	0	0	1	0	3	0	0	0	0	3	0	0	9	0	0	0	16	63
8:00 AM	0	0	7	0	4	0	1	0	0	2	0	0	8	2	2	0	26	76
8:15 AM	0	2	3	0	4	2	2	0	0	3	0	0	11	1	2	0	30	96
8:30 AM	0	8	19	0	6	11	1	0	0	4	2	0	10	0	2	0	63	135
8:45 AM	0	12	37	0	4	14	0	0	1	5	0	0	14	2	2	0	91	210
Peak 15-Min Flowrates	Northbound				Southbound				Eastbound				Westbound				Total	
	Left	Thru	Right	U	Left	Thru	Right	U	Left	Thru	Right	U	Left	Thru	Right	U		
All Vehicles	0	48	148	0	16	56	0	0	4	20	0	0	56	8	8	0	364	
Heavy Trucks	0	0	0		0	0	0		0	0	0		0	0	0		0	
Buses																		
Pedestrians		0				28				0				112			140	
Bicycles	0	0	0		24	0	4		0	0	0		0	0	12		40	
Scooters																		

Comments:

LOCATION: 1955 W -- 1950
CITY/STATE: Woods Cross, UT

QC JOB #: 16760716
DATE: Wed, Sep 18 2024

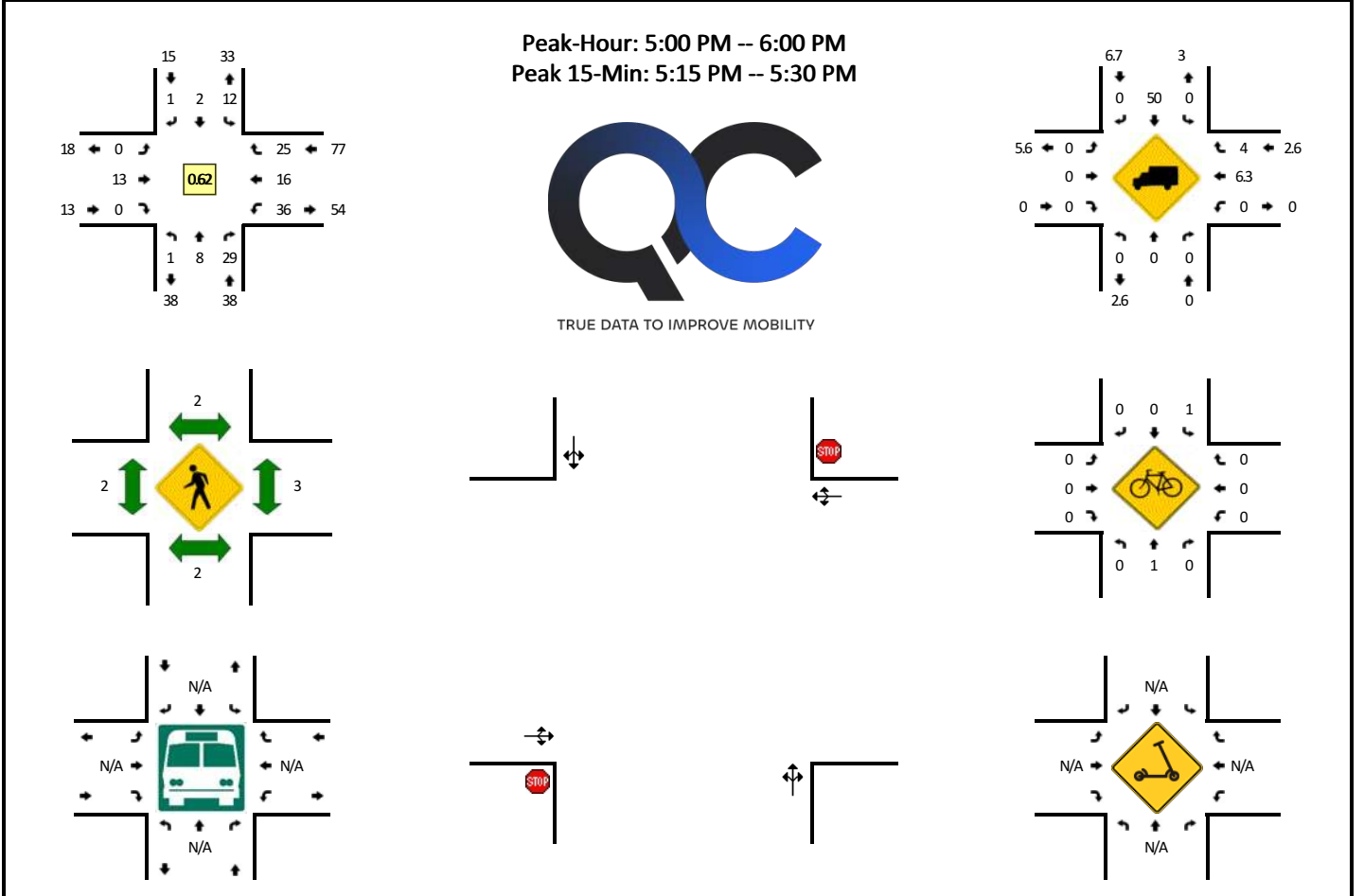

15-Min Count Period Beginning At	1955 W (Northbound)				1955 W (Southbound)				1950 (Eastbound)				1950 (Westbound)				Total	Hourly Totals
	Left	Thru	Right	U	Left	Thru	Right	U	Left	Thru	Right	U	Left	Thru	Right	U		
4:00 PM	0	3	12	0	6	1	0	0	0	4	0	0	2	3	4	0	35	
4:15 PM	1	1	9	0	5	0	0	0	0	2	0	0	2	5	6	0	31	
4:30 PM	0	0	3	0	4	0	0	0	1	1	1	0	1	2	4	0	17	
4:45 PM	0	2	4	0	5	0	0	0	0	2	0	0	2	2	6	0	23	106
5:00 PM	0	0	4	0	2	1	0	0	0	2	0	0	5	3	8	0	25	96
5:15 PM	0	4	15	0	6	1	0	0	0	3	0	0	17	7	5	0	58	123
5:30 PM	1	2	4	0	2	0	0	0	0	3	0	0	8	5	9	0	34	140
5:45 PM	0	2	6	0	2	0	1	0	0	5	0	0	6	1	3	0	26	143

Peak 15-Min Flowrates	Northbound				Southbound				Eastbound				Westbound				Total
	Left	Thru	Right	U	Left	Thru	Right	U	Left	Thru	Right	U	Left	Thru	Right	U	
All Vehicles	0	16	60	0	24	4	0	0	0	12	0	0	68	28	20	0	232
Heavy Trucks	0	0	0		0	4	0		0	0	0		0	4	4		12
Buses																	
Pedestrians		0				0				0				4			4
Bicycles	0	4	0		4	0	0		0	0	0		0	0	0		8
Scoters																	

Comments:

LOCATION: 625 W (Wildcat Way) -- 1950 S
CITY/STATE: Woods Cross, UT

QC JOB #: 16760717
DATE: Wed, Sep 18 2024

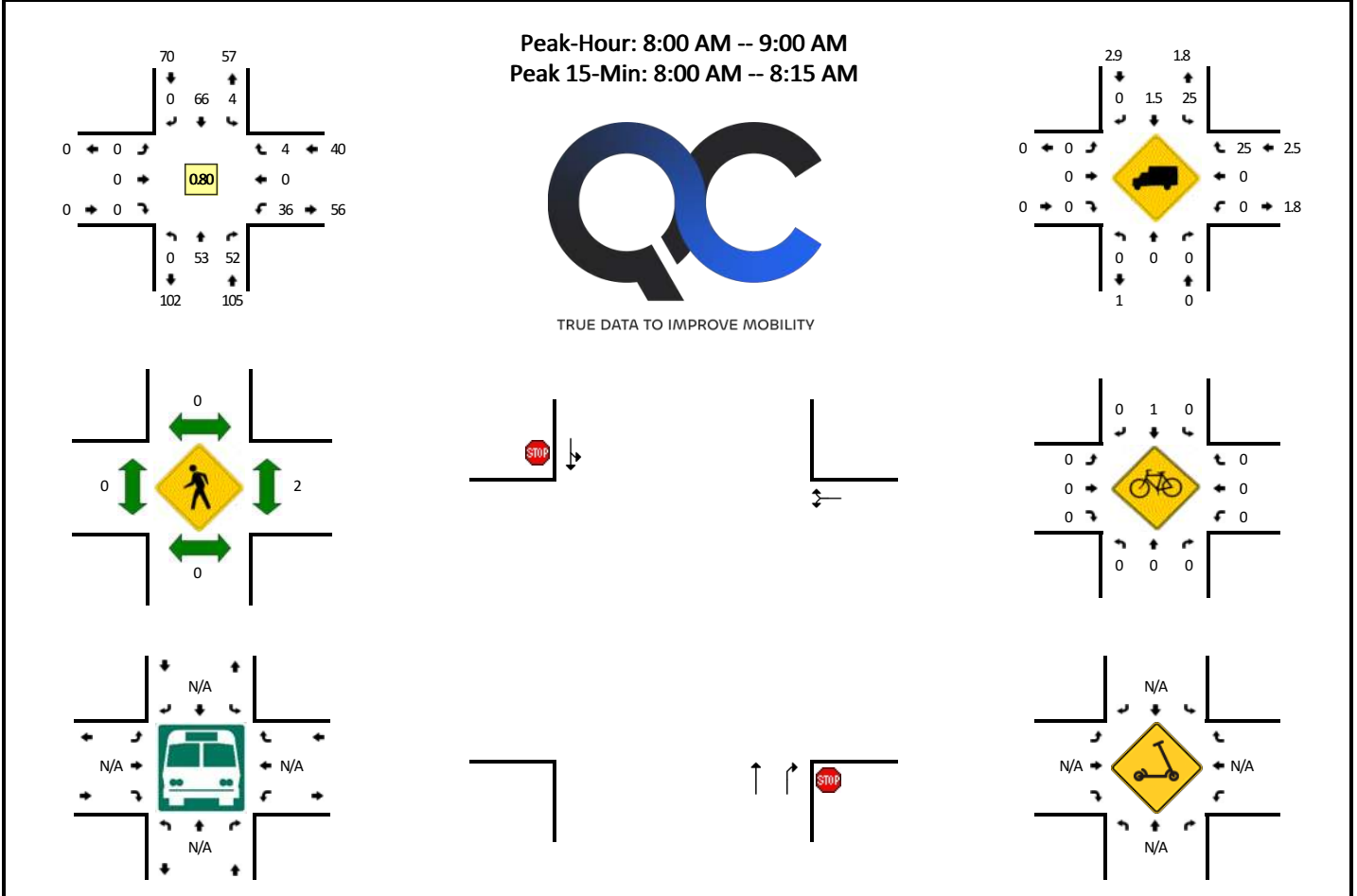

15-Min Count Period Beginning At	625 W (Wildcat Way) (Northbound)				625 W (Wildcat Way) (Southbound)				1950 S (Eastbound)				1950 S (Westbound)				Total	Hourly Totals
	Left	Thru	Right	U	Left	Thru	Right	U	Left	Thru	Right	U	Left	Thru	Right	U		
7:00 AM	0	4	3	0	0	19	0	0	0	0	0	0	18	0	0	0	44	
7:15 AM	0	2	3	0	1	10	0	0	0	0	0	0	8	0	0	0	24	
7:30 AM	0	4	4	0	0	7	0	0	0	0	0	0	5	0	0	0	20	
7:45 AM	0	15	9	0	0	14	0	0	0	0	0	0	5	0	0	0	43	131
8:00 AM	0	17	18	0	0	17	0	0	0	0	0	0	13	0	2	0	67	154
8:15 AM	0	14	14	0	1	18	0	0	0	0	0	0	6	0	0	0	53	183
8:30 AM	0	9	12	0	0	6	0	0	0	0	0	0	4	0	0	0	31	194
8:45 AM	0	13	8	0	3	25	0	0	0	0	0	0	13	0	2	0	64	215
Peak 15-Min Flowrates	Northbound				Southbound				Eastbound				Westbound				Total	
	Left	Thru	Right	U	Left	Thru	Right	U	Left	Thru	Right	U	Left	Thru	Right	U		
All Vehicles	0	68	72	0	0	68	0	0	0	0	0	0	52	0	8	0	268	
Heavy Trucks	0	0	0	0	0	4	0	0	0	0	0	0	0	0	0	0	4	
Buses																		
Pedestrians		0				0				0				0			0	
Bicycles	0	0	0		0	0	0		0	0	0		0	0	0		0	
Scoters																		

Comments: SB Stop Only

LOCATION: 625 W (Wildcat Way) -- 1950 S
CITY/STATE: Woods Cross, UT

QC JOB #: 16760718
DATE: Wed, Sep 18 2024

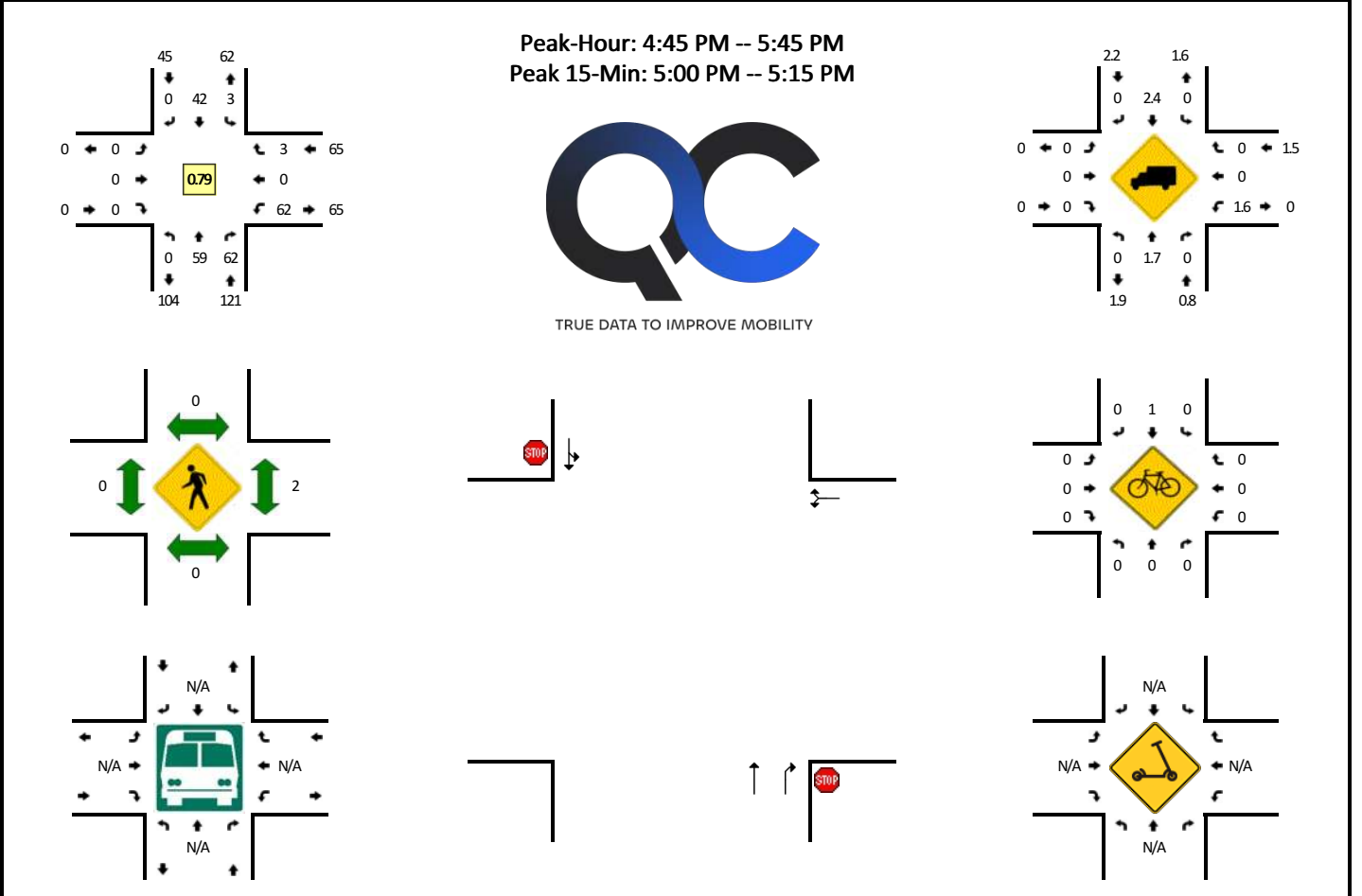

15-Min Count Period Beginning At	625 W (Wildcat Way) (Northbound)				625 W (Wildcat Way) (Southbound)				1950 S (Eastbound)				1950 S (Westbound)				Total	Hourly Totals
	Left	Thru	Right	U	Left	Thru	Right	U	Left	Thru	Right	U	Left	Thru	Right	U		
4:00 PM	0	16	13	0	1	5	0	0	0	0	0	0	14	0	1	0	50	
4:15 PM	0	17	14	0	0	4	0	0	0	0	0	0	13	0	4	0	52	
4:30 PM	0	12	12	0	1	6	0	0	0	0	0	0	6	0	0	0	37	
4:45 PM	0	16	16	0	0	11	0	0	0	0	0	0	20	0	0	0	63	202
5:00 PM	0	20	23	0	1	12	0	0	0	0	0	0	17	0	0	0	73	225
5:15 PM	0	14	14	0	0	6	0	0	0	0	0	0	14	0	2	0	50	223
5:30 PM	0	9	9	0	2	13	0	0	0	0	0	0	11	0	1	0	45	231
5:45 PM	0	22	11	0	0	10	0	0	0	0	0	0	10	0	0	0	53	221
Peak 15-Min Flowrates	Northbound				Southbound				Eastbound				Westbound				Total	
	Left	Thru	Right	U	Left	Thru	Right	U	Left	Thru	Right	U	Left	Thru	Right	U		
All Vehicles	0	80	92	0	4	48	0	0	0	0	0	0	68	0	0	0	292	
Heavy Trucks	0	0	0		0	0	0		0	0	0		0	0	0		0	
Buses																	0	
Pedestrians		0				0				0				0			0	
Bicycles	0	0	0		0	4	0		0	0	0		0	0	0		4	
Scoters																		

Comments: SB Stop Only

L2 Data Collection

L2DataCollection.com
Idaho (208) 860-7554 Utah (801) 413-2993

Study: JUB0101
Intersection: 800 West / 1500 South
City, State: Woods Cross, Utah
Control: All Stop

File Name : 800 West & 1500 South
Site Code : 00000000
Start Date : 11/8/2022
Page No : 1

Groups Printed- General Traffic - 3+ Axle Heavy Trucks

Start Time	800 West From North					1500 South From East					800 West From South					1500 South From West					Int. Total
	Right	Thru	Left	Peds	App. Total	Right	Thru	Left	Peds	App. Total	Right	Thru	Left	Peds	App. Total	Right	Thru	Left	Peds	App. Total	
06:00 AM	5	4	4	0	13	3	10	6	0	19	6	3	0	0	9	5	22	5	1	33	74
06:15 AM	4	11	2	0	17	1	15	6	0	22	7	2	1	1	11	10	17	1	0	28	78
06:30 AM	2	6	1	0	9	4	10	3	0	17	2	11	2	0	15	10	11	2	1	24	65
06:45 AM	7	7	3	1	18	4	21	9	1	35	6	6	1	1	14	10	30	5	0	45	112
Total	18	28	10	1	57	12	56	24	1	93	21	22	4	2	49	35	80	13	2	130	329
07:00 AM	5	11	13	0	29	9	22	14	1	46	18	5	3	4	30	13	66	3	0	82	187
07:15 AM	5	4	17	0	26	5	34	13	0	52	19	3	4	1	27	15	102	4	1	122	227
07:30 AM	11	10	8	0	29	11	59	10	0	80	18	6	7	0	31	21	59	7	0	87	227
07:45 AM	11	15	16	0	42	9	75	9	1	94	24	13	10	0	47	15	92	9	1	117	300
Total	32	40	54	0	126	34	190	46	2	272	79	27	24	5	135	64	319	23	2	408	941
08:00 AM	6	7	10	1	24	17	61	13	0	91	10	13	7	0	30	12	50	5	1	68	213
08:15 AM	7	12	8	0	27	7	25	9	4	45	10	20	9	1	40	9	46	11	0	66	178
08:30 AM	27	21	10	0	58	17	35	5	2	59	9	49	3	2	63	18	38	43	0	99	279
08:45 AM	16	38	16	0	70	14	29	10	0	53	22	12	4	2	40	7	53	7	2	69	232
Total	56	78	44	1	179	55	150	37	6	248	51	94	23	5	173	46	187	66	3	302	902
09:00 AM	14	11	9	0	34	6	29	6	0	41	10	11	11	1	33	15	44	6	1	66	174
09:15 AM	7	12	4	0	23	5	29	7	0	41	7	7	13	0	27	11	37	6	0	54	145
09:30 AM	2	6	7	0	15	2	29	12	1	44	8	6	4	0	18	6	38	4	0	48	125
09:45 AM	5	3	6	0	14	3	27	9	1	40	13	6	7	2	28	4	33	6	1	44	126
Total	28	32	26	0	86	16	114	34	2	166	38	30	35	3	106	36	152	22	2	212	570
10:00 AM	4	6	4	0	14	8	24	7	0	39	6	5	6	1	18	12	28	2	0	42	113
10:15 AM	5	6	9	0	20	4	32	7	1	44	6	7	14	0	27	13	34	3	0	50	141
10:30 AM	4	4	5	0	13	1	29	10	1	41	7	7	4	0	18	7	37	5	1	50	122
10:45 AM	4	6	6	0	16	3	42	7	0	52	13	7	9	0	29	8	39	2	0	49	146
Total	17	22	24	0	63	16	127	31	2	176	32	26	33	1	92	40	138	12	1	191	522
11:00 AM	3	4	6	0	13	3	35	7	0	45	5	7	10	1	23	8	39	6	0	53	134
11:15 AM	6	7	7	0	20	10	34	15	0	59	12	12	13	2	39	7	36	13	1	57	175
11:30 AM	15	16	13	0	44	8	29	8	0	45	12	7	12	1	32	12	42	3	2	59	180
11:45 AM	3	2	5	0	10	8	43	12	2	65	12	11	10	0	33	11	43	6	0	60	168
Total	27	29	31	0	87	29	141	42	2	214	41	37	45	4	127	38	160	28	3	229	657
12:00 PM	5	11	0	0	16	11	63	11	0	85	18	3	4	0	25	12	54	5	0	71	197
12:15 PM	7	12	7	1	27	10	47	5	1	63	11	14	7	0	32	9	49	4	0	62	184
12:30 PM	4	2	9	0	15	13	36	15	0	64	16	10	8	0	34	11	45	9	0	65	178
12:45 PM	15	11	6	0	32	4	53	13	2	72	13	12	12	1	38	7	40	7	2	56	198
Total	31	36	22	1	90	38	199	44	3	284	58	39	31	1	129	39	188	25	2	254	757
01:00 PM	2	8	3	0	13	5	44	12	2	63	6	7	14	4	31	10	42	2	0	54	161
01:15 PM	3	8	9	1	21	4	37	14	0	55	10	8	6	0	24	4	29	6	2	41	141
01:30 PM	4	8	4	0	16	12	38	10	0	60	16	7	12	0	35	12	23	2	2	39	150
01:45 PM	6	4	8	0	18	4	32	11	0	47	13	9	9	1	32	7	43	4	0	54	151
Total	15	28	24	1	68	25	151	47	2	225	45	31	41	5	122	33	137	14	4	188	603

L2 Data Collection

L2DataCollection.com
Idaho (208) 860-7554 Utah (801) 413-2993

Study: JUB0101
Intersection: 800 West / 1500 South
City, State: Woods Cross, Utah
Control: All Stop

File Name : 800 West & 1500 South
Site Code : 00000000
Start Date : 11/8/2022
Page No : 2

Groups Printed- General Traffic - 3+ Axle Heavy Trucks

Start Time	800 West From North					1500 South From East					800 West From South					1500 South From West					Int. Total
	Right	Thru	Left	Peds	App. Total	Right	Thru	Left	Peds	App. Total	Right	Thru	Left	Peds	App. Total	Right	Thru	Left	Peds	App. Total	
02:00 PM	1	5	7	0	13	5	33	9	0	47	14	6	8	0	28	10	39	1	0	50	138
02:15 PM	6	6	11	0	23	14	68	19	1	102	14	9	14	1	38	7	46	4	0	57	220
02:30 PM	9	9	3	0	21	12	102	18	0	132	12	13	8	3	36	12	50	4	0	66	255
02:45 PM	7	14	16	1	38	6	82	10	2	100	24	15	7	2	48	6	54	6	3	69	255
Total	23	34	37	1	95	37	285	56	3	381	64	43	37	6	150	35	189	15	3	242	868
03:00 PM	5	10	14	1	30	16	81	21	1	119	17	23	13	0	53	15	78	12	0	105	307
03:15 PM	4	17	8	3	32	21	49	21	0	91	24	27	9	1	61	6	56	17	1	80	264
03:30 PM	38	37	16	2	93	8	63	21	6	98	15	16	9	7	47	9	35	12	0	56	294
03:45 PM	9	12	17	0	38	7	46	15	1	69	31	16	13	0	60	14	64	11	0	89	256
Total	56	76	55	6	193	52	239	78	8	377	87	82	44	8	221	44	233	52	1	330	1121
04:00 PM	9	13	10	0	32	10	51	17	1	79	23	13	14	1	51	15	61	7	1	84	246
04:15 PM	12	12	19	0	43	12	51	18	0	81	15	16	16	0	47	13	48	5	2	68	239
04:30 PM	13	13	11	0	37	17	46	20	0	83	13	16	23	0	52	14	67	14	0	95	267
04:45 PM	8	18	17	0	43	12	52	16	1	81	19	12	19	0	50	22	53	7	1	83	257
Total	42	56	57	0	155	51	200	71	2	324	70	57	72	1	200	64	229	33	4	330	1009
05:00 PM	7	16	10	0	33	17	64	26	0	107	19	21	20	0	60	16	59	9	0	84	284
05:15 PM	9	13	13	0	35	13	69	17	1	100	15	14	16	1	46	14	84	10	1	109	290
05:30 PM	8	10	13	0	31	14	72	14	0	100	22	17	25	0	64	25	57	6	1	89	284
05:45 PM	10	10	9	0	29	15	49	12	0	76	18	11	30	3	62	18	54	4	0	76	243
Total	34	49	45	0	128	59	254	69	1	383	74	63	91	4	232	73	254	29	2	358	1101
06:00 PM	8	12	9	0	29	7	63	19	0	89	13	9	18	1	41	9	48	6	0	63	222
06:15 PM	6	7	8	0	21	8	60	16	0	84	10	17	21	0	48	16	52	2	1	71	224
06:30 PM	3	6	7	0	16	4	53	12	0	69	13	13	14	0	40	16	51	4	0	71	196
06:45 PM	4	6	12	1	23	7	41	24	4	76	21	10	19	2	52	13	56	6	1	76	227
Total	21	31	36	1	89	26	217	71	4	318	57	49	72	3	181	54	207	18	2	281	869
07:00 PM	6	6	5	0	17	8	45	18	0	71	8	14	13	0	35	9	37	4	0	50	173
07:15 PM	5	11	6	0	22	4	37	11	1	53	14	5	9	0	28	13	28	4	0	45	148
07:30 PM	4	3	3	0	10	6	36	17	0	59	5	12	10	0	27	4	36	3	0	43	139
07:45 PM	3	1	3	0	7	5	43	9	0	57	9	4	11	0	24	9	22	1	0	32	120
Total	18	21	17	0	56	23	161	55	1	240	36	35	43	0	114	35	123	12	0	170	580
Grand Total	418	560	482	12	1472	473	2484	705	39	3701	753	635	595	48	2031	636	2596	362	31	3625	10829
Apprch %	28.4	38	32.7	0.8		12.8	67.1	19	1.1		37.1	31.3	29.3	2.4		17.5	71.6	10	0.9		
Total %	3.9	5.2	4.5	0.1	13.6	4.4	22.9	6.5	0.4	34.2	7	5.9	5.5	0.4	18.8	5.9	24	3.3	0.3	33.5	
General Traffic	415	555	480	12	1462	469	2459	702	39	3669	751	631	591	48	2021	631	2572	357	31	3591	10743
% General Traffic	99.3	99.1	99.6	100	99.3	99.2	99	99.6	100	99.1	99.7	99.4	99.3	100	99.5	99.2	99.1	98.6	100	99.1	99.2
3+ Axle Heavy Trucks	3	5	2	0	10	4	25	3	0	32	2	4	4	0	10	5	24	5	0	34	86
% 3+ Axle Heavy Trucks	0.7	0.9	0.4	0	0.7	0.8	1	0.4	0	0.9	0.3	0.6	0.7	0	0.5	0.8	0.9	1.4	0	0.9	0.8

L2 Data Collection

L2DataCollection.com
 Idaho (208) 860-7554 Utah (801) 413-2993

Study: JUB0101
 Intersection: 800 West / 1500 South
 City, State: Woods Cross, Utah
 Control: All Stop

File Name : 800 West & 1500 South
 Site Code : 00000000
 Start Date : 11/8/2022
 Page No : 3

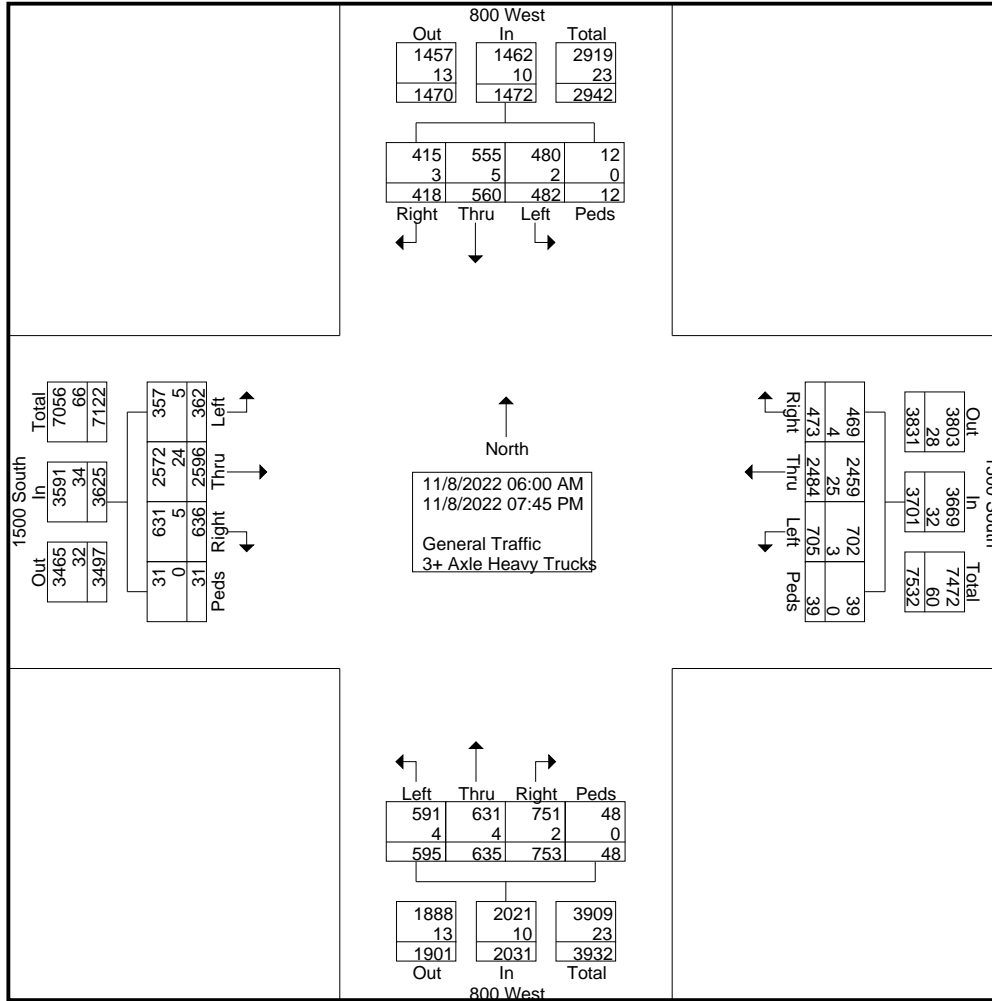

L2 Data Collection

L2DataCollection.com
 Idaho (208) 860-7554 Utah (801) 413-2993

Study: JUB0101
 Intersection: 800 West / 1500 South
 City, State: Woods Cross, Utah
 Control: All Stop

File Name : 800 West & 1500 South
 Site Code : 00000000
 Start Date : 11/8/2022
 Page No : 4

Start Time	800 West From North					1500 South From East					800 West From South					1500 South From West					Int. Total
	Right	Thru	Left	Peds	App. Total	Right	Thru	Left	Peds	App. Total	Right	Thru	Left	Peds	App. Total	Right	Thru	Left	Peds	App. Total	

Peak Hour Analysis From 06:00 AM to 11:45 AM - Peak 1 of 1
Peak Hour for Entire Intersection Begins at 07:45 AM

07:45 AM	11	15	16	0	42	9	75	9	1	94	24	13	10	0	47	15	92	9	1	117	300
08:00 AM	6	7	10	1	24	17	61	13	0	91	10	13	7	0	30	12	50	5	1	68	213
08:15 AM	7	12	8	0	27	7	25	9	4	45	10	20	9	1	40	9	46	11	0	66	178
08:30 AM	27	21	10	0	58	17	35	5	2	59	9	49	3	2	63	18	38	43	0	99	279
Total Volume	51	55	44	1	151	50	196	36	7	289	53	95	29	3	180	54	226	68	2	350	970
% App. Total	33.8	36.4	29.1	0.7		17.3	67.8	12.5	2.4		29.4	52.8	16.1	1.7		15.4	64.6	19.4	0.6		
PHF	.472	.655	.688	.250	.651	.735	.653	.692	.438	.769	.552	.485	.725	.375	.714	.750	.614	.395	.500	.748	.808
General Traffic	51	53	44	1	149	49	191	35	7	282	53	93	29	3	178	52	224	67	2	345	954
% General Traffic	100	96.4	100	100	98.7	98.0	97.4	97.2	100	97.6	100	97.9	100	100	98.9	96.3	99.1	98.5	100	98.6	98.4
3+ Axle Heavy Trucks	0	2	0	0	2	1	5	1	0	7	0	2	0	0	2	2	2	1	0	5	16
% 3+ Axle Heavy Trucks	0	3.6	0	0	1.3	2.0	2.6	2.8	0	2.4	0	2.1	0	0	1.1	3.7	0.9	1.5	0	1.4	1.6

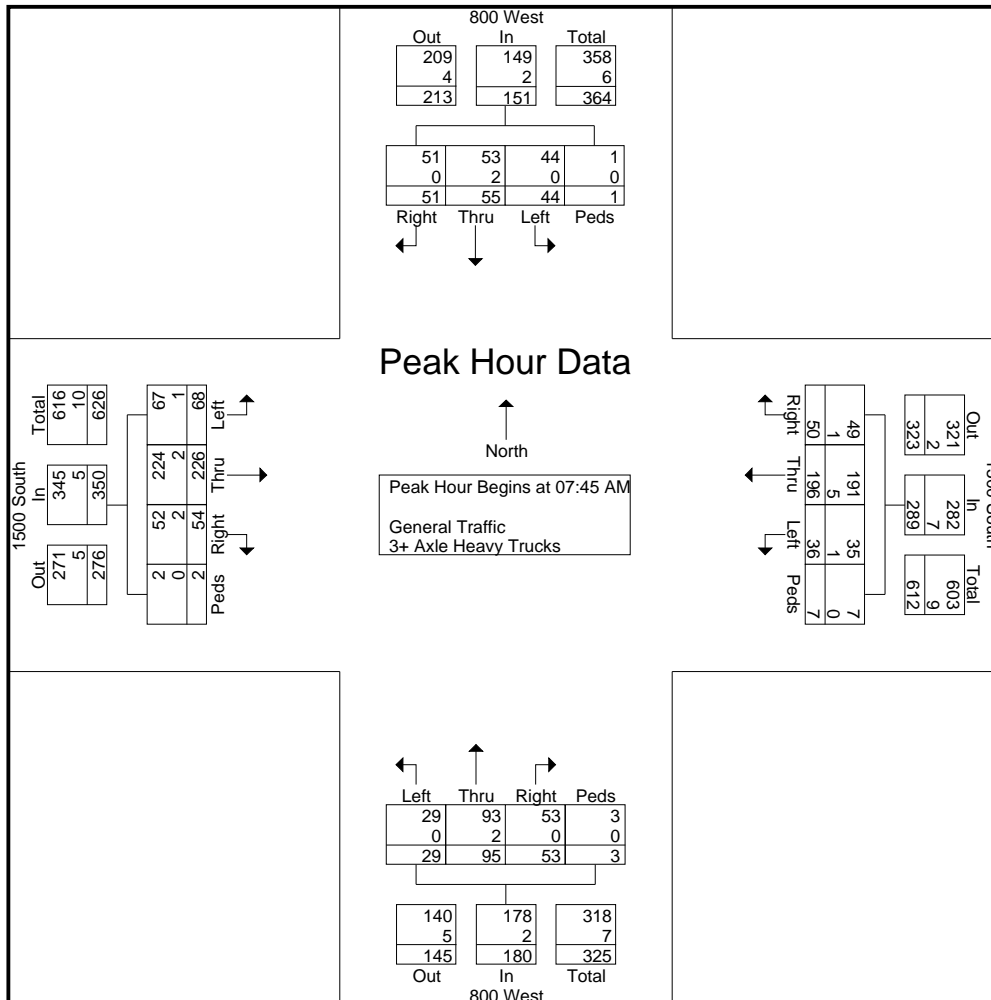

L2 Data Collection

L2DataCollection.com
Idaho (208) 860-7554 Utah (801) 413-2993

Study: JUB0101
Intersection: 800 West / 1500 South
City, State: Woods Cross, Utah
Control: All Stop

File Name : 800 West & 1500 South
Site Code : 00000000
Start Date : 11/8/2022
Page No : 5

Start Time	800 West From North					1500 South From East					800 West From South					1500 South From West					Int. Total
	Right	Thru	Left	Peds	App. Total	Right	Thru	Left	Peds	App. Total	Right	Thru	Left	Peds	App. Total	Right	Thru	Left	Peds	App. Total	

Peak Hour Analysis From 06:00 AM to 11:45 AM - Peak 1 of 1
Peak Hour for Each Approach Begins at:

	08:15 AM					07:15 AM					07:45 AM					07:00 AM				
+0 mins.	7	12	8	0	27	5	34	13	0	52	24	13	10	0	47	13	66	3	0	82
+15 mins.	27	21	10	0	58	11	59	10	0	80	10	13	7	0	30	15	102	4	1	122
+30 mins.	16	38	16	0	70	9	75	9	1	94	10	20	9	1	40	21	59	7	0	87
+45 mins.	14	11	9	0	34	17	61	13	0	91	9	49	3	2	63	15	92	9	1	117
Total Volume	64	82	43	0	189	42	229	45	1	317	53	95	29	3	180	64	319	23	2	408
% App. Total	33.9	43.4	22.8	0		13.2	72.2	14.2	0.3		29.4	52.8	16.1	1.7		15.7	78.2	5.6	0.5	
PHF	.593	.539	.672	.000	.675	.618	.763	.865	.250	.843	.552	.485	.725	.375	.714	.762	.782	.639	.500	.836
General Traffic	64	80	43	0	187	42	225	42	1	310	53	93	29	3	178	63	317	22	2	404
% General Traffic	100	97.6	100	0	98.9	100	98.3	93.3	100	97.8	100	97.9	100	100	98.9	98.4	99.4	95.7	100	99
3+ Axle Heavy Trucks	0	2	0	0	2	0	4	3	0	7	0	2	0	0	2	1	2	1	0	4
% 3+ Axle Heavy Trucks	0	2.4	0	0	1.1	0	1.7	6.7	0	2.2	0	2.1	0	0	1.1	1.6	0.6	4.3	0	1

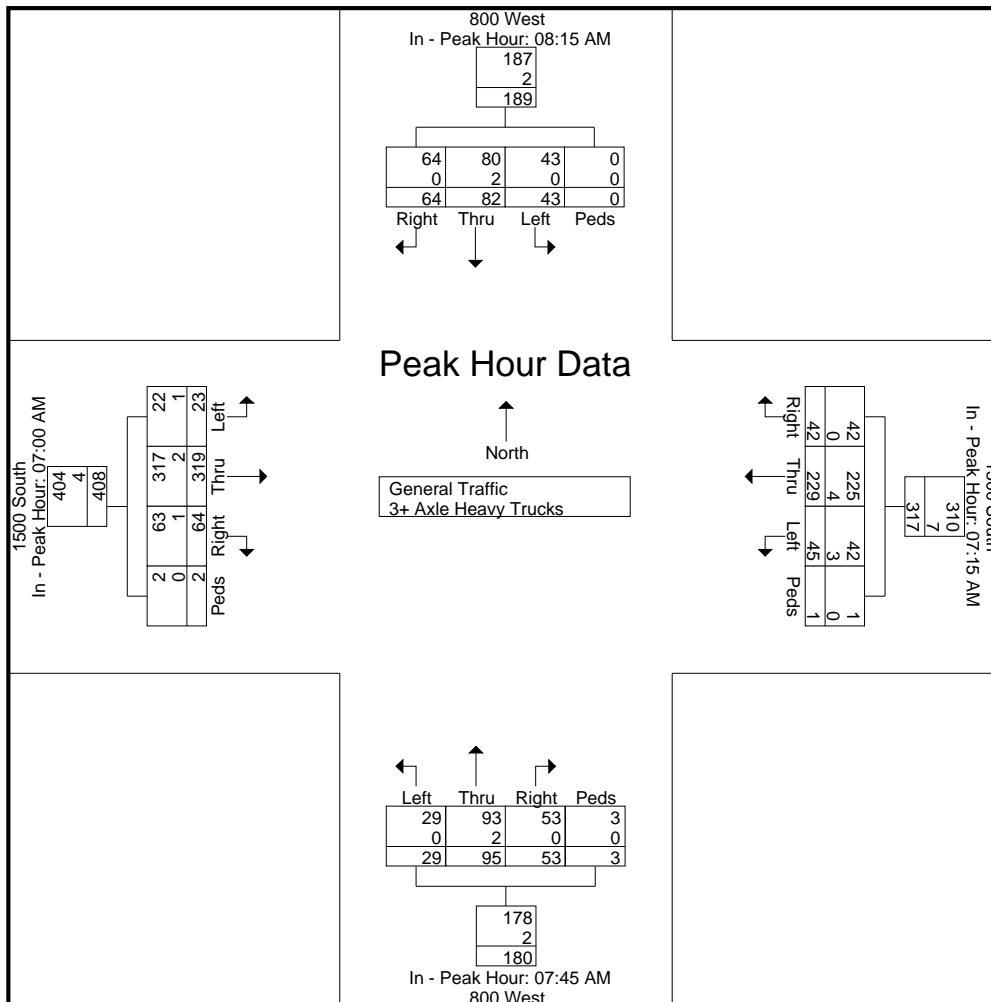

L2 Data Collection

L2DataCollection.com
Idaho (208) 860-7554 Utah (801) 413-2993

Study: JUB0101
Intersection: 800 West / 1500 South
City, State: Woods Cross, Utah
Control: All Stop

File Name : 800 West & 1500 South
Site Code : 00000000
Start Date : 11/8/2022
Page No : 6

Start Time	800 West From North					1500 South From East					800 West From South					1500 South From West					Int. Total
	Right	Thru	Left	Peds	App. Total	Right	Thru	Left	Peds	App. Total	Right	Thru	Left	Peds	App. Total	Right	Thru	Left	Peds	App. Total	
Peak Hour Analysis From 12:00 PM to 07:45 PM - Peak 1 of 1																					
Peak Hour for Entire Intersection Begins at 03:00 PM																					
03:00 PM	5	10	14	1	30	16	81	21	1	119	17	23	13	0	53	15	78	12	0	105	307
03:15 PM	4	17	8	3	32	21	49	21	0	91	24	27	9	1	61	6	56	17	1	80	264
03:30 PM	38	37	16	2	93	8	63	21	6	98	15	16	9	7	47	9	35	12	0	56	294
03:45 PM	9	12	17	0	38	7	46	15	1	69	31	16	13	0	60	14	64	11	0	89	256
Total Volume	56	76	55	6	193	52	239	78	8	377	87	82	44	8	221	44	233	52	1	330	1121
% App. Total	29	39.4	28.5	3.1		13.8	63.4	20.7	2.1		39.4	37.1	19.9	3.6		13.3	70.6	15.8	0.3		
PHF	.368	.514	.809	.500	.519	.619	.738	.929	.333	.792	.702	.759	.846	.286	.906	.733	.747	.765	.250	.786	.913
General Traffic	54	76	55	6	191	51	235	78	8	372	86	82	43	8	219	44	231	52	1	328	1110
% General Traffic	96.4	100	100	100	99.0	98.1	98.3	100	100	98.7	98.9	100	97.7	100	99.1	100	99.1	100	100	99.4	99.0
3+ Axle Heavy Trucks	2	0	0	0	2	1	4	0	0	5	1	0	1	0	2	0	2	0	0	2	11
% 3+ Axle Heavy Trucks	3.6	0	0	0	1.0	1.9	1.7	0	0	1.3	1.1	0	2.3	0	0.9	0	0.9	0	0	0.6	1.0

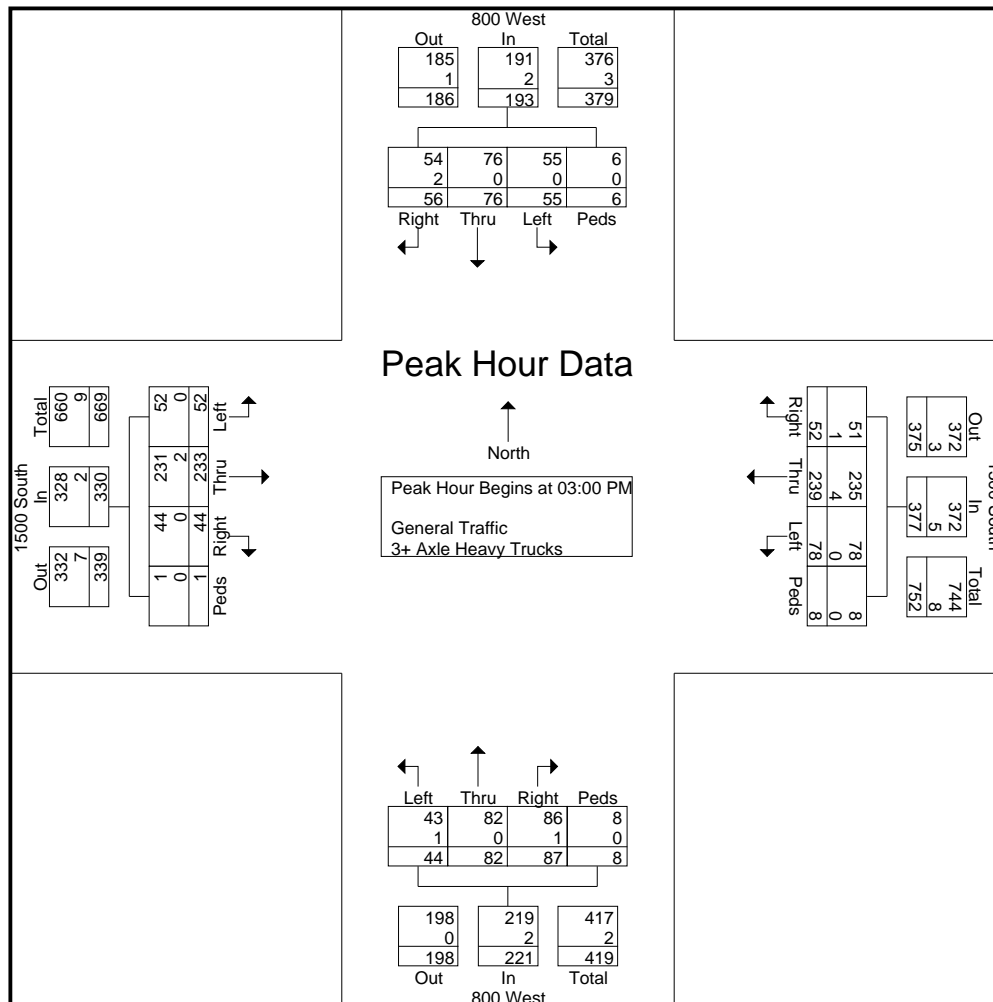

L2 Data Collection

L2DataCollection.com
Idaho (208) 860-7554 Utah (801) 413-2993

Study: JUB0101
Intersection: 800 West / 1500 South
City, State: Woods Cross, Utah
Control: All Stop

File Name : 800 West & 1500 South
Site Code : 00000000
Start Date : 11/8/2022
Page No : 7

Start Time	800 West From North					1500 South From East					800 West From South					1500 South From West					Int. Total
	Right	Thru	Left	Peds	App. Total	Right	Thru	Left	Peds	App. Total	Right	Thru	Left	Peds	App. Total	Right	Thru	Left	Peds	App. Total	
Peak Hour Analysis From 12:00 PM to 07:45 PM - Peak 1 of 1																					
Peak Hour for Each Approach Begins at:																					
	03:30 PM					02:15 PM					05:00 PM					04:30 PM					
+0 mins.	38	37	16	2	93	14	68	19	1	102	19	21	20	0	60	14	67	14	0	95	
+15 mins.	9	12	17	0	38	12	102	18	0	132	15	14	16	1	46	22	53	7	1	83	
+30 mins.	9	13	10	0	32	6	82	10	2	100	22	17	25	0	64	16	59	9	0	84	
+45 mins.	12	12	19	0	43	16	81	21	1	119	18	11	30	3	62	14	84	10	1	109	
Total Volume	68	74	62	2	206	48	333	68	4	453	74	63	91	4	232	66	263	40	2	371	
% App. Total	33	35.9	30.1	1		10.6	73.5	15	0.9		31.9	27.2	39.2	1.7		17.8	70.9	10.8	0.5		
PHF	.447	.500	.816	.250	.554	.750	.816	.810	.500	.858	.841	.750	.758	.333	.906	.750	.783	.714	.500	.851	
General Traffic	67	74	61	2	204	47	329	68	4	448	74	63	91	4	232	66	263	40	2	371	
% General Traffic	98.	100	98.	100	99	97.	98.	100	100	98.9	100	100	100	100	100	100	100	100	100	100	
3+ Axle Heavy Trucks	5	4	0	0	9	8	0	0	0	8	0	0	0	0	0	0	0	0	0	0	
% 3+ Axle Heavy Trucks	1.5	0	1.6	0	1	2.1	1.2	0	0	1.1	0	0	0	0	0	0	0	0	0	0	

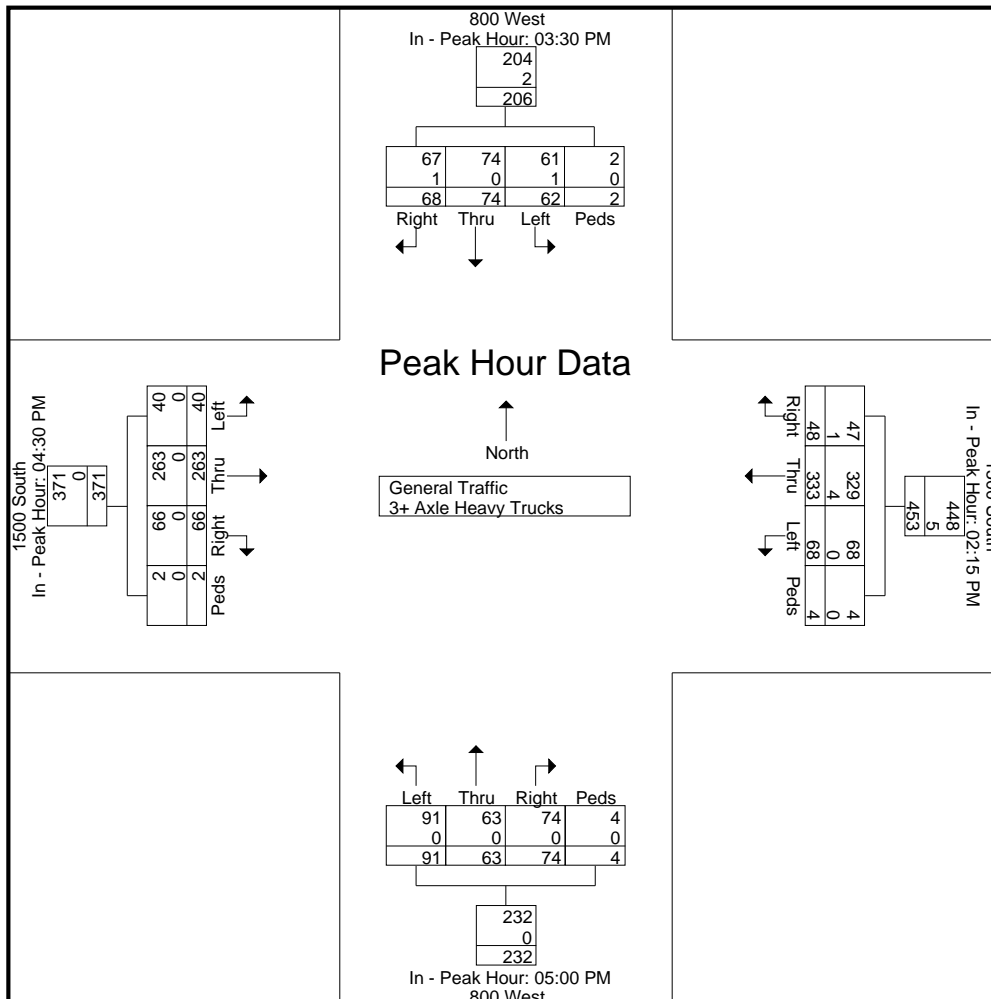

INTERSECTION: 1970 S @ 1100 W
 DATE OF TMC: Thursday, September 12, 2024
 TIME: 6:00:00 AM
 AGENCY:



AM Hour		SOUTHBOUND							NORTHBOUND							WESTBOUND							EASTBOUND							GRAND
Start	End	EB Ped	WB Ped	Left	Thru	Right	Total	EB Ped	WB Ped	Left	Thru	Right	Total	SB Ped	NB Ped	Left	Thru	Right	Total	SB Ped	NB Ped	Left	Thru	Right	Total	TOTAL				
6:00 AM	6:15 AM	0	0	1	23	5	29	0	0	0	6	0	6	0	0	0	0	0	0	1	0	1	0	1	2	37				
6:15 AM	6:30 AM	0	0	0	20	10	30	1	0	9	7	0	16	0	0	0	0	0	0	0	0	1	1	0	2	48				
6:30 AM	6:45 AM	0	0	2	27	10	39	0	0	3	3	2	8	0	0	0	0	0	0	1	0	12	0	7	19	66				
6:45 AM	7:00 AM	1	0	1	28	13	42	1	0	1	11	7	19	1	0	1	0	0	1	0	0	1	0	1	2	64				
7:00 AM	7:15 AM	0	0	0	27	7	34	4	0	0	8	0	8	1	0	0	0	0	0	0	0	2	0	0	2	44				
7:15 AM	7:30 AM	0	0	1	43	23	67	1	0	5	10	0	15	0	0	0	0	0	0	1	0	3	0	0	3	85				
7:30 AM	7:45 AM	0	0	0	48	79	127	0	0	25	14	0	39	0	0	0	0	0	0	0	0	26	0	28	54	220				
7:45 AM	8:00 AM	0	0	0	40	101	141	0	0	21	10	0	31	1	0	0	0	0	0	1	0	77	0	57	134	306				
8:00 AM	8:15 AM	1	0	0	34	11	45	0	0	0	20	2	22	0	0	0	0	0	0	1	0	38	0	7	45	112				
8:15 AM	8:30 AM	0	0	0	29	7	36	1	0	2	9	0	11	4	0	0	0	0	0	0	0	5	0	1	6	53				
8:30 AM	8:45 AM	0	0	0	23	6	29	2	0	3	14	0	17	2	0	1	0	0	1	0	0	5	0	1	6	53				
8:45 AM	9:00 AM	0	0	0	37	10	47	2	0	4	15	0	19	0	0	0	0	0	0	2	0	6	0	2	8	74				
TOTAL		2	0	5	379	282	666	12	0	73	127	11	211	9	0	2	0	0	2	7	0	177	1	105	283	1162				

INTERSECTION: 1970 S @ 1100 W
 DATE OF TMC: Thursday, September 12, 2024
 TIME: 6:00:00 AM
 AGENCY:



AM Peak Hour		SOUTHBOUND							NORTHBOUND							WESTBOUND							EASTBOUND							GRAND
Start	End	EB Ped	WB Ped	Left	Thru	Right	Total	EB Ped	WB Ped	Left	Thru	Right	Total	SB Ped	NB Ped	Left	Thru	Right	Total	SB Ped	NB Ped	Left	Thru	Right	Total	TOTAL				
7:15 AM	7:30 AM	0	0	1	43	23	67	1	0	5	10	0	15	0	0	0	0	0	0	1	0	3	0	0	3	85				
7:30 AM	7:45 AM	0	0	0	48	79	127	0	0	25	14	0	39	0	0	0	0	0	0	0	0	26	0	28	54	220				
7:45 AM	8:00 AM	0	0	0	40	101	141	0	0	21	10	0	31	1	0	0	0	0	0	1	0	77	0	57	134	306				
8:00 AM	8:15 AM	1	0	0	34	11	45	0	0	0	20	2	22	0	0	0	0	0	0	1	0	38	0	7	45	112				
TOTAL		1	0	1	165	214	380	1	0	51	54	2	107	1	0	0	0	0	0	3	0	144	0	92	236	723				
PHF								0.67							0.69							0.00							0.44	0.59
%HGV								2.0%							4.7%							50.0%							0.7%	2.2%

1970 S @ 1100 W

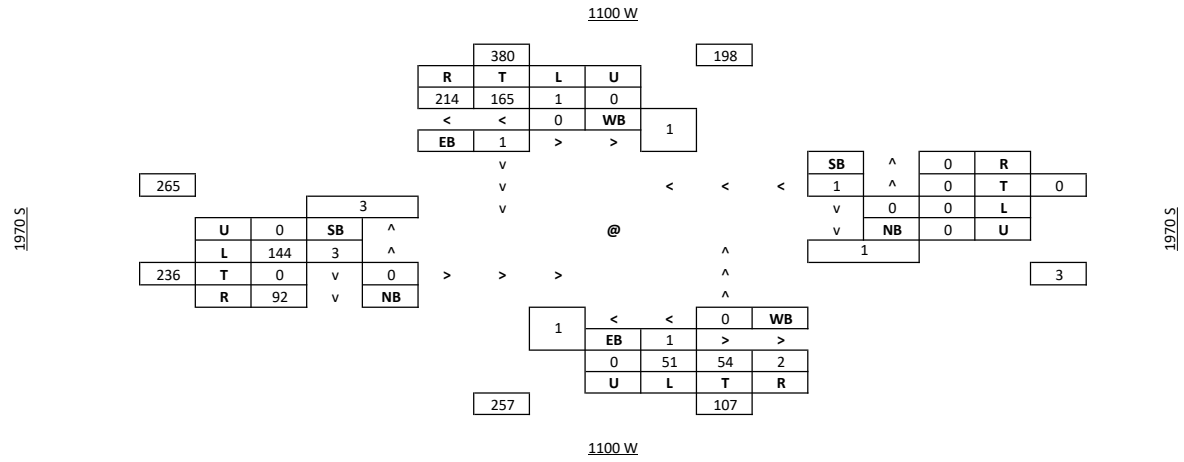

INTERSECTION: 1970 S @ 1100 W
 DATE OF TMC: Tuesday, September 10, 2024
 TIME: 12:00:00 PM
 AGENCY:



PM Hour		SOUTHBOUND							NORTHBOUND							WESTBOUND							EASTBOUND							GRAND
Start	End	EB Ped	WB Ped	Left	Thru	Right	Total	EB Ped	WB Ped	Left	Thru	Right	Total	SB Ped	NB Ped	Left	Thru	Right	Total	SB Ped	NB Ped	Left	Thru	Right	Total	TOTAL				
3:00 PM	3:15 PM	1	0	0	0	0	0	3	0	0	0	0	0	1	0	0	0	0	0	0	0	0	0	0	0	0				
3:15 PM	3:30 PM	3	0	0	0	0	0	14	0	0	0	0	0	3	0	0	0	0	0	1	0	0	0	0	0	0				
3:30 PM	3:45 PM	2	0	0	0	0	0	10	0	0	0	0	0	2	0	0	0	0	0	0	0	0	0	0	0	0				
3:45 PM	4:00 PM	0	0	0	0	0	0	12	0	0	0	0	0	0	0	0	0	0	0	0	0	0	0	0	0	0				
4:00 PM	4:15 PM	0	0	0	14	6	20	7	0	1	42	0	43	1	0	0	0	0	0	1	0	14	0	4	18	81				
4:15 PM	4:30 PM	0	0	0	13	4	17	8	0	0	39	0	39	7	0	0	0	0	0	2	0	19	1	2	22	78				
4:30 PM	4:45 PM	0	0	0	20	7	27	7	0	4	39	0	43	0	0	0	0	0	0	0	0	26	0	4	30	100				
4:45 PM	5:00 PM	0	0	0	15	9	24	9	0	3	52	0	55	1	0	0	0	0	0	1	0	12	0	5	17	96				
5:00 PM	5:15 PM	0	0	0	22	1	23	6	0	0	57	0	57	0	0	0	0	0	0	0	0	10	0	2	12	92				
5:15 PM	5:30 PM	0	0	0	30	9	39	9	0	1	50	0	51	0	0	0	0	0	0	1	0	11	0	4	15	105				
5:30 PM	5:45 PM	0	0	0	19	6	25	13	0	1	58	0	59	0	0	0	0	0	0	1	0	21	0	4	25	109				
5:45 PM	6:00 PM	0	0	0	28	6	34	15	0	0	35	0	35	0	0	1	0	0	1	0	0	10	0	1	11	81				
TOTAL		6	0	0	161	48	209	113	0	10	372	0	382	15	0	1	0	0	1	7	0	123	1	26	150	742				

INTERSECTION: 1970 S @ 1100 W
 DATE OF TMC: Tuesday, September 10, 2024
 TIME: 12:00:00 PM
 AGENCY:



PM Peak Hour		SOUTHBOUND							NORTHBOUND							WESTBOUND							EASTBOUND							GRAND
Start	End	EB Ped	WB Ped	Left	Thru	Right	Total	EB Ped	WB Ped	Left	Thru	Right	Total	SB Ped	NB Ped	Left	Thru	Right	Total	SB Ped	NB Ped	Left	Thru	Right	Total	TOTAL				
4:45 PM	5:00 PM	0	0	0	15	9	24	9	0	3	52	0	55	1	0	0	0	0	0	1	0	12	0	5	17	96				
5:00 PM	5:15 PM	0	0	0	22	1	23	6	0	0	57	0	57	0	0	0	0	0	0	0	0	10	0	2	12	92				
5:15 PM	5:30 PM	0	0	0	30	9	39	9	0	1	50	0	51	0	0	0	0	0	0	1	0	11	0	4	15	105				
5:30 PM	5:45 PM	0	0	0	19	6	25	13	0	1	58	0	59	0	0	0	0	0	0	1	0	21	0	4	25	109				
TOTAL		0	0	0	86	25	111	37	0	5	217	0	222	1	0	0	0	0	0	3	0	54	0	15	69	402				
PHF								0.71							0.94							0.00							0.69	0.92
%HGV								0.5%							0.8%							0.0%							0.7%	0.7%

1970 S @ 1100 W

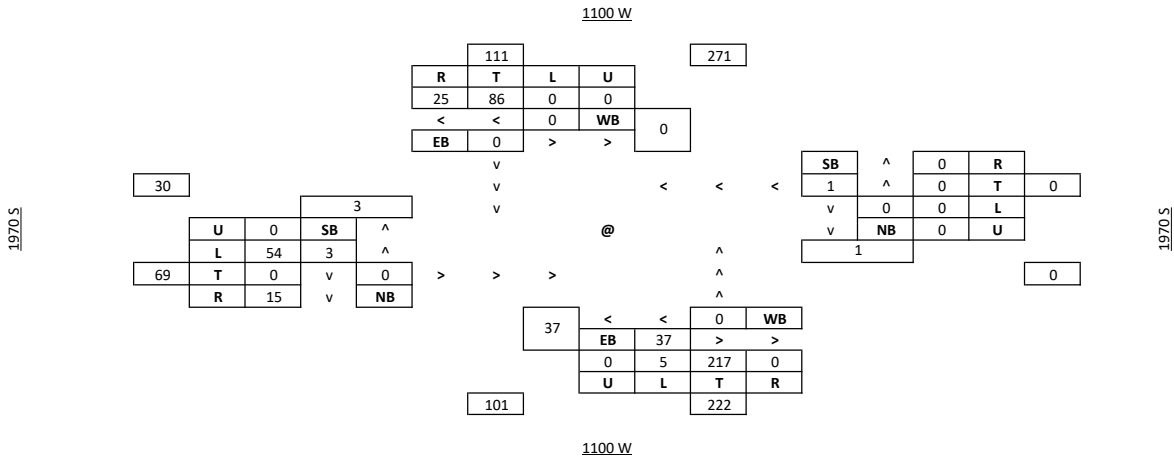

Existing Condition

Intersection		Movement	Existing Condition AM					Existing Condition PM				
			Volume	Delay (sec)	LOS	Queue Length (Ft)	V/C Ratio	Volume	Delay (sec)	LOS	Queue Length (Ft)	V/C Ratio
800 W / 1100 S (TWSC)	1100 S	WBL	11	12.9	B	17.5	0.18	10	10.5	B	2.5	0.05
		WBR	24					14				
	800 W	NBT	93	-	-	-	-	158	-	-	-	-
		NBR	175					11				
	800 W	SBL	49	8.3	A	7.5	0.08	13	7.7	A	0.0	0.01
		SBT	165					177				
Mountain View / 1500 S (Roundabout)	1500 S	EBL	0	3.2	A	0.0	0.03	2	3.3	A	0.0	0.03
		EBT	25					22				
		EBR	5					2				
	1500 S	WBL	20	3.0	A	0.0	0.04	47	4.0	A	25.0	0.17
		WBT	10					35				
		WBR	11					105				
	Mountain View	NBL	4	3.4	A	0.0	0.06	0	3.3	A	0.0	0.05
		NBT	1					0				
		NBR	35					40				
	Mountain View	SBL	21	3.2	A	0.0	0.03	20	3.5	A	0.0	0.05
		SBT	6					2				
		SBR	0					1				
			Overall		3.2	A			3.8	A		
1600 W / 1500 S (TWSC)	1500 S	EBT	103	-	-	-	-	211	-	-	-	-
		EBR	19					63				
	1500 S	WBL	9	7.6	A	0.0	0.01	22	8.0	A	2.5	0.02
		WBT	156					202				
	1600 W	NBL	60	11.4	B	15.0	0.18	34	12.6	B	10.0	0.11
		NBR	24					11				
1450 W / 1500 S (TWSC)	1500 S	EBL	3	7.6	A	0.0	0.00	24	0.0	A	-	-
		EBT	129					208				
		EBR	2					2				
	1500 S	WBL	1	7.5	A	0.0	0.00	10	7.7	A	0.0	0.01
		WBT	141					237				
		WBR	12					10				
	1450 W	NBL	5	10.4	B	2.5	0.02	0	9.6	A	2.5	0.03
		NBT	0					0				
		NBR	3					8				
	1450 W	SBL	22	10.8	B	7.5	0.09	13	12.6	B	7.5	0.08
		SBT	0					0				
SBR		21	11									

Existing Condition

Intersection	Movement	Existing Condition AM					Existing Condition PM						
		Volume	Delay (sec)	LOS	Queue Length (Ft)	V/C Ratio	Volume	Delay (sec)	LOS	Queue Length (Ft)	V/C Ratio		
1100 W / 1500 S (AWSC)	1500 S	EBL	23	15.7	C	47.5	0.40	31	19.6	C	87.5	0.57	
		EBT	124					177					
		EBR	33					27					
	1500 S	WBL	119	22.4	C	115.0	0.65	81	39.7	E	237.5	0.86	
		WBT	113					227					
		WBR	20					50					
	1100 W	NBL	18	26.3	D	157.5	0.74	25	21.2	C	105.0	0.62	
		NBT	129					183					
		NBR	118					78					
	1100 W	SBL	17	20.8	C	107.5	0.63	37	17.3	C	65.0	0.49	
		SBT	155					93					
		SBR	17					67					
800 W / 1500 S (Signalized)	1500 S	EBL	68	8.2	A	12.5	0.17	52	9.1	A	10.0	0.14	
		EBT	226	6.9	A	37.5	0.54	233	7.2	A	42.5	0.50	
		EBR	54					44					
	1500 S	WBL	36	8.3	A	7.5	0.09	78	9.2	A	15.0	0.20	
		WBT	196	6.5	A	30.0	0.47	239	7.3	A	45.0	0.54	
		WBR	50					52					
	800 W	NBL	29	8.6	A	5.0	0.08	43	9.9	A	7.5	0.10	
		NBT	95	8.3	A	27.5	0.44	82	8.1	A	27.5	0.36	
		NBR	53					86					
	800 W	SBL	44	9.4	A	10.0	0.14	55	9.6	A	17.5	0.21	
		SBT	55	8.0	A	20.0	0.36	76	8.8	A	37.5	0.49	
		SBR	51					56					
	Overall			7.5	A				8.1	A			
	1955 W / 1950 S (TWSC)	1950 S	EBL	1	11.0	B	2.5	0.04	0	9.9	A	2.5	0.03
			EBT	14					13				
EBR			2	0									
1950 S		WBL	43	10.6	B	7.5	0.10	36	9.8	A	12.5	0.13	
		WBT	5					16					
		WBR	8					25					
1955 W		NBL	0	0.0	A	0.0	-	1	7.2	A	0.0	0.00	
		NBT	22					8					
		NBR	66					29					
1955 W		SBL	18	7.7	A	2.5	0.02	12	7.4	A	0.0	0.01	
		SBT	27					2					
		SBR	4					1					

Existing Condition

Intersection		Movement	Existing Condition AM					Existing Condition PM				
			Volume	Delay (sec)	LOS	Queue Length (Ft)	V/C Ratio	Volume	Delay (sec)	LOS	Queue Length (Ft)	V/C Ratio
1425 W / 1900 S (AWSC)	1900 S	EBL	0	7.3	A	2.5	0.03	2	7.3	A	5.0	0.06
		EBT	16					25				
		EBR	3					12				
	1900 S	WBL	25	7.7	A	7.5	0.09	40	7.7	A	10.0	0.12
		WBT	14					30				
		WBR	4					11				
	1425 W	NBL	13	7.2	A	7.5	0.10	10	7.2	A	5.0	0.08
		NBT	0					4				
		NBR	50					49				
	1425 W	SBL	6	7.4	A	0.0	0.01	7	7.5	A	2.5	0.03
		SBT	1					3				
		SBR	0					2				
1100 W / 1970 S (TWSC)	1970 S	EBL	144	16.1	C	35.0	0.33	54	11.7	B	7.5	0.10
		EBT	0	10.6	B	12.5	0.13	0	8.9	A	2.5	0.02
		EBR	92					15				
	Approach X	WBL	0	0.0	A	-	-	0	0.0	A	-	-
		WBT	0					0				
		WBR	0					0				
	1100 W	NBL	51	8.3	A	5.0	0.05	5	7.5	A	0.0	0.00
		NBT	54					217				
		NBR	2					0				
	1100 W	SBL	1	7.3	A	0.0	0.00	0	0.0	A	0.0	-
		SBT	165					86				
		SBR	214					25				
625 W / 1950 S (TWSC)	1950 S	SEL	4	9.2	A	10.0	0.11	3	9.1	A	5.0	0.06
		SER	66					42				
	625 W	NEL	53	7.4	A	2.5	0.05	59	7.5	A	5.0	0.06
		NET	52					62				
	625 W	SWT	36	-	-	-	-	62	-	-	-	-
		SWR	4	-	-	-	-	3	-	-	-	-
Mountain View / 2260 S (Yield Control)	2260 S	EBL	5	7.7	A	-	-	6	7.2	A	-	-
		EBT	6					6				
		EBR	0					0				
	2260 S	WBL	2	7.1	A	-	-	6	7.0	A	-	-
		WBT	1					12				
		WBR	7					13				
	Mountain View	NBL	0	7.0	A	-	-	0	6.9	A	-	-
		NBT	5					6				
		NBR	5					5				
	Mountain View	SBL	7	7.5	A	-	-	7	7.2	A	-	-
		SBT	3					4				
		SBR	3					1				

2050 No Build Condition

Intersection		Movement	2050 No Build Condition AM					2050 No Build Condition PM				
			Volume	Delay (sec)	LOS	Queue Length (Ft)	V/C Ratio	Volume	Delay (sec)	LOS	Queue Length (Ft)	V/C Ratio
800 W / 1100 S (TWSC)	1100 S	WBL	12	15.8	C	25.0	0.26	11	11.1	B	5.0	0.06
		WBR	27					16				
	800 W	NBT	105	-	-	-	-	179	7.8	A	0.0	0.02
		NBR	198					12				
	800 W	SBL	69	8.6	A	10.0	0.11	18	-	-	-	-
		SBT	233					250				
Mountain View / 1500 S (Roundabout)	1500 S	EBL	0	3.3	A	0.0	0.04	2	3.4	A	0.0	0.03
		EBT	28					25				
		EBR	6					2				
	1500 S	WBL	23	3.1	A	0.0	0.04	53	4.2	A	25.0	0.19
		WBT	11					40				
		WBR	12					119				
	Mountain View	NBL	5	3.5	A	0.0	0.07	0	3.4	A	0.0	0.05
		NBT	1					0				
		NBR	40					45				
	Mountain View	SBL	24	3.2	A	0.0	0.03	23	3.6	A	0.0	0.06
		SBT	7					2				
		SBR	0					1				
			Overall		3.3	A			3.9	A		
1600 W / 1500 S (TWSC)	1500 S	EBT	116	-	-	-	-	238	-	-	-	-
		EBR	21					71				
	1500 S	WBL	10	7.7	A	0.0	0.01	25	8.1	A	2.5	0.02
		WBT	176					228				
	1600 W	NBL	68	12.0	B	20.0	0.21	38	13.6	B	12.5	0.14
NBR		27	12									
1450 W / 1500 S (TWSC)	1500 S	EBL	4	8.0	A	0.0	0.00	34	8.6	A	2.5	0.04
		EBT	185					298				
		EBR	3					3				
	1500 S	WBL	2	7.6	A	0.0	0.00	18	8.0	A	0.0	0.02
		WBT	258					434				
		WBR	22					18				
	1450 W	NBL	6	12.7	B	2.5	0.03	0	10.3	B	2.5	0.03
		NBT	0					0				
		NBR	3					9				
	1450 W	SBL	45	14.4	B	27.5	0.27	13	17.0	C	15.0	0.17
		SBT	0					0				
SBR		47	23									

2050 No Build Condition

Intersection	Movement	2050 No Build Condition AM					2050 No Build Condition PM						
		Volume	Delay (sec)	LOS	Queue Length (Ft)	V/C Ratio	Volume	Delay (sec)	LOS	Queue Length (Ft)	V/C Ratio		
1100 W / 1500 S (AWSC)	1500 S	EBL	37	63.4	F	155.0	1.30	50	134.6	F	312.5	1.76	
		EBT	200					286					
		EBR	53					44					
	1500 S	WBL	185	190.6	F	435.0	1.82	126	383.0	F	855.0	2.33	
		WBT	175					352					
		WBR	31					78					
	1100 W	NBL	48	765.0	F	1987.5	2.78	67	487.7	F	1177.5	2.44	
		NBT	344					488					
		NBR	315					208					
	1100 W	SBL	19	83.6	F	212.5	1.47	42	50.5	F	115.0	1.18	
		SBT	175					105					
		SBR	19					76					
800 W / 1500 S (Signalized)	1500 S	EBL	83	10.6	B	22.5	0.25	64	12.5	B	20.0	0.21	
		EBT	278	7.2	A	62.5	0.57	286	7.6	A	67.5	0.53	
		EBR	66					54					
	1500 S	WBL	53	9.6	A	12.5	0.15	116	11.2	B	35.0	0.31	
		WBT	291	7.4	A	67.5	0.59	355	8.7	A	97.5	0.68	
		WBR	74					77					
	800 W	NBL	33	11.1	B	10.0	0.10	49	13.0	B	15.0	0.14	
		NBT	107	10.5	B	47.5	0.49	93	10.2	B	45.0	0.40	
		NBR	60					97					
	800 W	SBL	50	12.3	B	17.5	0.19	62	12.6	B	30.0	0.27	
		SBT	62	10.0	B	37.5	0.40	86	11.1	B	65.0	0.54	
		SBR	58					63					
	Overall			8.7	A				9.7	A			
	1955 W / 1950 S (TWSC)	1950 S	EBL	1	11.3	B	2.5	0.05	0	10.0	B	2.5	0.03
			EBT	16					15				
EBR			2	0									
1950 S		WBL	49	11.0	B	10.0	0.12	41	10.0	A	12.5	0.15	
		WBT	6					18					
		WBR	9					28					
1955 W		NBL	0	0.0	A	0.0	-	1	7.2	A	0.0	0.00	
		NBT	25					9					
		NBR	75					33					
1955 W		SBL	20	7.8	A	2.5	0.02	14	7.4	A	2.5	0.02	
		SBT	31					2					
		SBR	5					1					

2050 No Build Condition

Intersection		Movement	2050 No Build Condition AM					2050 No Build Condition PM				
			Volume	Delay (sec)	LOS	Queue Length (Ft)	V/C Ratio	Volume	Delay (sec)	LOS	Queue Length (Ft)	V/C Ratio
1425 W / 1900 S (AWSC)	1900 S	EBL	0	7.4	A	2.5	0.03	2	7.4	A	5.0	0.07
		EBT	18					28				
		EBR	3					14				
	1900 S	WBL	28	7.8	A	7.5	0.10	45	7.9	A	12.5	0.14
		WBT	16					34				
		WBR	5					12				
	1425 W	NBL	15	7.3	A	10.0	0.11	11	7.3	A	7.5	0.09
		NBT	0					5				
		NBR	57					55				
	1425 W	SBL	7	7.5	A	0.0	0.01	7	7.5	A	2.5	0.03
		SBT	1					3				
		SBR	0					2				
1100 W / 1970 S (TWSC)	1970 S	EBL	197	67.6	F	175.0	0.85	74	17.0	C	20.0	0.21
		EBT	0	13.4	B	22.5	0.24	0	9.3	A	2.5	0.03
		EBR	126					21				
	Approach X	WBL	0	0.0	A	-	-	0	0.0	A	-	-
		WBT	0					0				
		WBR	0					0				
	1100 W	NBL	96	9.6	A	10.0	0.12	9	7.7	A	0.0	0.01
		NBT	101					407				
		NBR	4					0				
	1100 W	SBL	2	7.4	A	0.0	0.00	0	0.0	A	0.0	-
		SBT	285					149				
		SBR	370					43				
625 W / 1950 S (TWSC)	1950 S	SEL	5	9.3	A	12.5	0.13	3	9.2	A	5.0	0.07
		SER	75					47				
	625 W	NEL	60	7.5	A	5.0	0.05	67	7.6	A	5.0	0.06
		NET	59					70				
	625 W	SWT	41	-	-	-	-	70	-	-	-	-
		SWR	5	-	-	-	-	3	-	-	-	-
Mountain View / 2260 S (Yield Control)	2260 S	EBL	6	7.8	A	-	-	7	7.3	A	-	-
		EBT	7					7				
		EBR	0					0				
	2260 S	WBL	2	7.1	A	-	-	7	7.0	A	-	-
		WBT	1					14				
		WBR	8					15				
	Mountain View	NBL	0	7.0	A	-	-	0	6.9	A	-	-
		NBT	6					7				
		NBR	6					6				
	Mountain View	SBL	8	7.5	A	-	-	8	7.3	A	-	-
		SBT	3					5				
		SBR	3					1				

2050 Build Condition

Intersection		Movement	2050 Build Condition AM					2050 Build Condition PM				
			Volume	Delay (sec)	LOS	Queue Length (Ft)	V/C Ratio	Volume	Delay (sec)	LOS	Queue Length (Ft)	V/C Ratio
800 W / 1100 S (TWSC)	1100 S	WBL	12	15.8	C	25.0	0.26	11	11.1	B	5.0	0.06
		WBR	27					16				
	800 W	NBT	105	-	-	-	-	179	7.8	A	0.0	0.02
		NBR	198					12				
	800 W	SBL	69	8.6	A	10.0	0.11	18	-	-	-	-
		SBT	233					250				
Mountain View / 1500 S (Roundabout)	1500 S	EBL	0	3.3	A	0.0	0.04	2	3.4	A	0.0	0.03
		EBT	28					25				
		EBR	6					2				
	1500 S	WBL	23	3.1	A	0.0	0.04	53	4.2	A	25.0	0.19
		WBT	11					40				
		WBR	12					119				
	Mountain View	NBL	5	3.5	A	0.0	0.07	0	3.4	A	0.0	0.05
		NBT	1					0				
		NBR	40					45				
	Mountain View	SBL	24	3.2	A	0.0	0.03	23	3.6	A	0.0	0.06
		SBT	7					2				
		SBR	0					1				
	Overall				3.3	A			3.9	A		
	1600 W / 1500 S (TWSC)	1500 S	EBT	116	-	-	-	-	238	-	-	-
EBR			21	71								
1500 S		WBL	10	7.7	A	0.0	0.01	25	8.1	A	2.5	0.02
		WBT	176					228				
1600 W		NBL	68	12.0	B	20.0	0.21	38	13.6	B	12.5	0.14
		NBR	27					12				
1450 W / 1500 S (TWSC)	1500 S	EBL	4	8.0	A	0.0	0.00	34	8.6	A	2.5	0.04
		EBT	185					298				
		EBR	3					3				
	1500 S	WBL	2	7.6	A	0.0	0.00	18	8.0	A	0.0	0.02
		WBT	258					434				
		WBR	22					18				
	1450 W	NBL	6	12.7	B	2.5	0.03	0	10.3	B	2.5	0.03
		NBT	0					0				
		NBR	3					9				
	1450 W	SBL	45	14.4	B	27.5	0.27	13	17.0	C	15.0	0.17
		SBT	0					0				
		SBR	47					23				

2050 Build Condition

Intersection	Movement	2050 Build Condition AM					2050 Build Condition PM					
		Volume	Delay (sec)	LOS	Queue Length (Ft)	V/C Ratio	Volume	Delay (sec)	LOS	Queue Length (Ft)	V/C Ratio	
1100 W / 1500 S (Signalized)	1500 S	EBL	37	12.0	B	12.5	0.09	50	16.9	B	22.5	0.20
		EBT	200	10.0	B	70.0	0.38	286	10.1	B	102.5	0.52
		EBR	53					44				
	1500 S	WBL	185	15.5	B	90.0	0.51	126	15.3	B	60.0	0.39
		WBT	175	10.0	B	70.0	0.38	352	12.4	B	170.0	0.72
		WBR	31					78				
	1100 W	NBL	48	13.0	B	22.5	0.17	67	12.3	B	22.5	0.15
		NBT	344	12.1	B	157.5	0.69	488	15.1	B	190.0	0.76
		NBR	315	13.5	B	155.0	0.75	208	10.7	B	62.5	0.39
	1100 W	SBL	19	16.4	B	12.5	0.13	42	18.8	B	20.0	0.20
		SBT	175	10.1	B	87.5	0.45	105	10.3	B	57.5	0.34
		SBR	19					76				
		Overall		12.1	B				12.7	B		
800 W / 1500 S (Signalized)	1500 S	EBL	83	10.6	B	22.5	0.25	64	12.5	B	20.0	0.21
		EBT	278	7.2	A	62.5	0.57	286	7.6	A	67.5	0.53
		EBR	66					54				
	1500 S	WBL	53	9.6	A	12.5	0.15	116	11.2	B	35.0	0.31
		WBT	291	7.4	A	67.5	0.59	355	8.7	A	97.5	0.68
		WBR	74					77				
	800 W	NBL	33	11.1	B	10.0	0.10	49	13.0	B	15.0	0.14
		NBT	107	10.5	B	47.5	0.49	93	10.2	B	45.0	0.40
		NBR	60					97				
	800 W	SBL	50	12.3	B	17.5	0.19	62	12.6	B	30.0	0.27
		SBT	62	10.0	B	37.5	0.40	86	11.1	B	65.0	0.54
		SBR	58					63				
		Overall		8.7	A				9.7	A		
1955 W / 1950 S (TWSC)	1950 S	EBL	1	11.3	B	2.5	0.05	0	10.0	B	2.5	0.03
		EBT	16					15				
		EBR	2					0				
	1950 S	WBL	49	11.0	B	10.0	0.12	41	10.0	A	12.5	0.15
		WBT	6					18				
		WBR	9					28				
	1955 W	NBL	0	0.0	A	0.0	-	1	7.2	A	0.0	0.00
		NBT	25					9				
		NBR	75					33				
	1955 W	SBL	20	7.8	A	2.5	0.02	14	7.4	A	2.5	0.02
SBT		31	2									
SBR		5	1									

2050 Build Condition

Intersection		Movement	2050 Build Condition AM					2050 Build Condition PM				
			Volume	Delay (sec)	LOS	Queue Length (Ft)	V/C Ratio	Volume	Delay (sec)	LOS	Queue Length (Ft)	V/C Ratio
1425 W / 1900 S (AWSC)	1900 S	EBL	0	7.4	A	2.5	0.03	2	7.4	A	5.0	0.07
		EBT	18					28				
		EBR	3					14				
	1900 S	WBL	28	7.8	A	7.5	0.10	45	7.9	A	12.5	0.14
		WBT	16					34				
		WBR	5					12				
	1425 W	NBL	15	7.3	A	10.0	0.11	11	7.3	A	7.5	0.09
		NBT	0					5				
		NBR	57					55				
	1425 W	SBL	7	7.5	A	0.0	0.01	7	7.5	A	2.5	0.03
		SBT	1					3				
		SBR	0					2				
1100 W / 1970 S (TWSC)	1970 S	EBL	197	31.5	D	100.0	0.63	74	16.5	C	20.0	0.20
		EBT	0	11.1	B	17.5	0.19	0	9.2	A	2.5	0.03
		EBR	126					21				
	Approach X	WBL	0	0.0	A	-	-	0	0.0	A	-	-
		WBT	0					0				
		WBR	0					0				
	1100 W	NBL	96	9.6	A	10.0	0.12	9	7.7	A	0.0	0.01
		NBT	101					407				
		NBR	4					0				
	1100 W	SBL	2	7.4	A	0.0	0.00	0	0.0	A	0.0	-
		SBT	285	0.0	A	-	-	149	-	-	-	-
		SBR	370					43				
625 W / 1950 S (TWSC)	1950 S	SEL	5	9.3	A	12.5	0.13	3	9.2	A	5.0	0.07
		SER	75					47				
	625 W	NEL	60	7.5	A	5.0	0.05	67	7.6	A	5.0	0.06
		NET	59					70				
	625 W	SWT	41	-	-	-	-	70	-	-	-	-
		SWR	5	-	-	-	-	3	-	-	-	-
Mountain View / 2260 S (Yield Control)	2260 S	EBL	6	7.8	A	-	-	7	7.3	A	-	-
		EBT	7					7				
		EBR	0					0				
	2260 S	WBL	2	7.1	A	-	-	7	7.0	A	-	-
		WBT	1					14				
		WBR	8					15				
	Mountain View	NBL	0	7.0	A	-	-	0	6.9	A	-	-
		NBT	6					7				
		NBR	6					6				
	Mountain View	SBL	8	7.5	A	-	-	8	7.3	A	-	-
		SBT	3					5				
		SBR	3					1				

Existing Condition - AM

Intersection						
Int Delay, s/veh	2.3					
Movement	WBL	WBR	NBT	NBR	SBL	SBT
Lane Configurations	Y		B			A
Traffic Vol, veh/h	11	24	93	175	49	165
Future Vol, veh/h	11	24	93	175	49	165
Conflicting Peds, #/hr	0	0	0	0	0	0
Sign Control	Stop	Stop	Free	Free	Free	Free
RT Channelized	-	None	-	None	-	None
Storage Length	0	-	-	-	-	-
Veh in Median Storage, #	0	-	0	-	-	0
Grade, %	0	-	0	-	-	0
Peak Hour Factor	34	34	68	68	54	54
Heavy Vehicles, %	0	0	0	2	0	4
Mvmt Flow	32	71	137	257	91	306

Major/Minor	Minor1	Major1	Major2			
Conflicting Flow All	752	265	0	0	394	0
Stage 1	265	-	-	-	-	-
Stage 2	487	-	-	-	-	-
Critical Hdwy	6.4	6.2	-	-	4.1	-
Critical Hdwy Stg 1	5.4	-	-	-	-	-
Critical Hdwy Stg 2	5.4	-	-	-	-	-
Follow-up Hdwy	3.5	3.3	-	-	2.2	-
Pot Cap-1 Maneuver	381	778	-	-	1175	-
Stage 1	784	-	-	-	-	-
Stage 2	622	-	-	-	-	-
Platoon blocked, %			-	-		-
Mov Cap-1 Maneuver	345	778	-	-	1175	-
Mov Cap-2 Maneuver	345	-	-	-	-	-
Stage 1	784	-	-	-	-	-
Stage 2	564	-	-	-	-	-

Approach	WB	NB	SB
HCM Ctrl Dly, s/v	12.9	0	1.9
HCM LOS	B		

Minor Lane/Major Mvmt	NBT	NBRWBLn1	SBL	SBT
Capacity (veh/h)	-	-	558	412
HCM Lane V/C Ratio	-	-	0.184	0.077
HCM Ctrl Dly (s/v)	-	-	12.9	8.3
HCM Lane LOS	-	-	B	A
HCM 95th %tile Q(veh)	-	-	0.7	0.3

Intersection				
Intersection Delay, s/veh	3.2			
Intersection LOS	A			
Approach	EB	WB	NB	SB
Entry Lanes	1	1	1	1
Conflicting Circle Lanes	1	1	1	1
Adj Approach Flow, veh/h	40	49	80	32
Demand Flow Rate, veh/h	42	51	82	35
Vehicles Circulating, veh/h	59	12	62	44
Vehicles Exiting, veh/h	20	132	39	19
Ped Vol Crossing Leg, #/h	0	0	0	0
Ped Cap Adj	1.000	1.000	1.000	1.000
Approach Delay, s/veh	3.2	3.0	3.4	3.2
Approach LOS	A	A	A	A
Lane	Left	Left	Left	Left
Designated Moves	LTR	LTR	LTR	LTR
Assumed Moves	LTR	LTR	LTR	LTR
RT Channelized				
Lane Util	1.000	1.000	1.000	1.000
Follow-Up Headway, s	2.609	2.609	2.609	2.609
Critical Headway, s	4.976	4.976	4.976	4.976
A (Intercept)	1380	1380	1380	1380
B (Slope)	1.02e-3	1.02e-3	1.02e-3	1.02e-3
Entry Flow, veh/h	42	51	82	35
Cap Entry Lane, veh/h	1299	1363	1295	1319
Entry HV Adj Factor	0.945	0.961	0.976	0.914
Flow Entry, veh/h	40	49	80	32
Cap Entry, veh/h	1228	1310	1264	1206
V/C Ratio	0.032	0.037	0.063	0.027
Control Delay, s/veh	3.2	3.0	3.4	3.2
LOS	A	A	A	A
95th %tile Queue, veh	0	0	0	0

Intersection						
Int Delay, s/veh	3					
Movement	EBT	EBR	WBL	WBT	NBL	NBR
Lane Configurations						
Traffic Vol, veh/h	103	19	9	156	60	24
Future Vol, veh/h	103	19	9	156	60	24
Conflicting Peds, #/hr	0	0	0	0	0	0
Sign Control	Free	Free	Free	Free	Stop	Stop
RT Channelized	-	None	-	None	-	None
Storage Length	-	-	-	-	0	-
Veh in Median Storage, #	0	-	-	0	0	-
Grade, %	0	-	-	0	0	-
Peak Hour Factor	82	82	75	75	70	70
Heavy Vehicles, %	9	5	11	4	2	4
Mvmt Flow	126	23	12	208	86	34

Major/Minor	Major1	Major2	Minor1		
Conflicting Flow All	0	0	149	0	369
Stage 1	-	-	-	-	137
Stage 2	-	-	-	-	232
Critical Hdwy	-	-	4.21	-	6.42
Critical Hdwy Stg 1	-	-	-	-	5.42
Critical Hdwy Stg 2	-	-	-	-	5.42
Follow-up Hdwy	-	-	2.299	-	3.518
Pot Cap-1 Maneuver	-	-	1379	-	631
Stage 1	-	-	-	-	889
Stage 2	-	-	-	-	807
Platoon blocked, %	-	-	-	-	-
Mov Cap-1 Maneuver	-	-	1379	-	625
Mov Cap-2 Maneuver	-	-	-	-	625
Stage 1	-	-	-	-	889
Stage 2	-	-	-	-	799

Approach	EB	WB	NB
HCM Ctrl Dly, s/v	0	0.42	11.36
HCM LOS			B

Minor Lane/Major Mvmt	NBLn1	EBT	EBR	WBL	WBT
Capacity (veh/h)	686	-	-	98	-
HCM Lane V/C Ratio	0.175	-	-	0.009	-
HCM Ctrl Dly (s/v)	11.4	-	-	7.6	0
HCM Lane LOS	B	-	-	A	A
HCM 95th %tile Q(veh)	0.6	-	-	0	-

Intersection												
Int Delay, s/veh	2											
Movement	EBL	EBT	EBR	WBL	WBT	WBR	NBL	NBT	NBR	SBL	SBT	SBR
Lane Configurations		↕			↕			↕			↕	
Traffic Vol, veh/h	3	129	2	1	141	12	5	0	3	22	0	21
Future Vol, veh/h	3	129	2	1	141	12	5	0	3	22	0	21
Conflicting Peds, #/hr	0	0	0	0	0	0	0	0	0	0	0	0
Sign Control	Free	Free	Free	Free	Free	Free	Stop	Stop	Stop	Stop	Stop	Stop
RT Channelized	-	-	None	-	-	None	-	-	None	-	-	None
Storage Length	-	-	-	-	-	-	-	-	-	-	-	-
Veh in Median Storage, #	-	0	-	-	0	-	-	0	-	-	0	-
Grade, %	-	0	-	-	0	-	-	0	-	-	0	-
Peak Hour Factor	88	88	88	79	79	79	67	67	67	67	67	67
Heavy Vehicles, %	0	6	0	0	3	25	0	0	0	14	0	10
Mvmt Flow	3	147	2	1	178	15	7	0	4	33	0	31

Major/Minor	Major1			Major2			Minor1			Minor2		
Conflicting Flow All	194	0	0	149	0	0	336	351	148	342	344	186
Stage 1	-	-	-	-	-	-	155	155	-	189	189	-
Stage 2	-	-	-	-	-	-	181	196	-	153	156	-
Critical Hdwy	4.1	-	-	4.1	-	-	7.1	6.5	6.2	7.24	6.5	6.3
Critical Hdwy Stg 1	-	-	-	-	-	-	6.1	5.5	-	6.24	5.5	-
Critical Hdwy Stg 2	-	-	-	-	-	-	6.1	5.5	-	6.24	5.5	-
Follow-up Hdwy	2.2	-	-	2.2	-	-	3.5	4	3.3	3.626	4	3.39
Pot Cap-1 Maneuver	1392	-	-	1445	-	-	622	577	904	590	582	836
Stage 1	-	-	-	-	-	-	853	773	-	786	748	-
Stage 2	-	-	-	-	-	-	825	742	-	821	773	-
Platoon blocked, %		-	-		-	-						
Mov Cap-1 Maneuver	1392	-	-	1445	-	-	596	575	904	585	580	836
Mov Cap-2 Maneuver	-	-	-	-	-	-	596	575	-	585	580	-
Stage 1	-	-	-	-	-	-	850	771	-	785	747	-
Stage 2	-	-	-	-	-	-	794	742	-	815	771	-

Approach	EB			WB			NB			SB		
HCM Ctrl Dly, s/v	0.17			0.05			10.36			10.79		
HCM LOS							B			B		

Minor Lane/Major Mvmt	NBLn1	EBL	EBT	EBR	WBL	WBT	WBR	SBLn1
Capacity (veh/h)	684	40	-	-	12	-	-	685
HCM Lane V/C Ratio	0.017	0.002	-	-	0.001	-	-	0.094
HCM Ctrl Dly (s/v)	10.4	7.6	0	-	7.5	0	-	10.8
HCM Lane LOS	B	A	A	-	A	A	-	B
HCM 95th %tile Q(veh)	0.1	0	-	-	0	-	-	0.3

Intersection	
Intersection Delay, s/veh	22.2
Intersection LOS	C

Movement	EBL	EBT	EBR	WBL	WBT	WBR	NBL	NBT	NBR	SBL	SBT	SBR
Lane Configurations		↕			↕			↕			↕	
Traffic Vol, veh/h	23	124	33	119	113	20	18	129	118	17	155	17
Future Vol, veh/h	23	124	33	119	113	20	18	129	118	17	155	17
Peak Hour Factor	0.94	0.94	0.94	0.76	0.76	0.76	0.66	0.66	0.66	0.57	0.57	0.57
Heavy Vehicles, %	13	2	9	3	3	5	11	2	3	0	0	18
Mvmt Flow	24	132	35	157	149	26	27	195	179	30	272	30
Number of Lanes	0	1	0	0	1	0	0	1	0	0	1	0

Approach	EB	WB	NB	SB
Opposing Approach	WB	EB	SB	NB
Opposing Lanes	1	1	1	1
Conflicting Approach Left	SB	NB	EB	WB
Conflicting Lanes Left	1	1	1	1
Conflicting Approach Right	NB	SB	WB	EB
Conflicting Lanes Right	1	1	1	1
HCM Control Delay, s/veh	15.7	22.4	26.3	20.8
HCM LOS	C	C	D	C

Lane	NBLn1	EBLn1	WBLn1	SBLn1
Vol Left, %	7%	13%	47%	9%
Vol Thru, %	49%	69%	45%	82%
Vol Right, %	45%	18%	8%	9%
Sign Control	Stop	Stop	Stop	Stop
Traffic Vol by Lane	265	180	252	189
LT Vol	18	23	119	17
Through Vol	129	124	113	155
RT Vol	118	33	20	17
Lane Flow Rate	402	191	332	332
Geometry Grp	1	1	1	1
Degree of Util (X)	0.74	0.402	0.65	0.629
Departure Headway (Hd)	6.631	7.555	7.061	6.828
Convergence, Y/N	Yes	Yes	Yes	Yes
Cap	546	475	511	527
Service Time	4.683	5.622	5.117	4.886
HCM Lane V/C Ratio	0.736	0.402	0.65	0.63
HCM Control Delay, s/veh	26.3	15.7	22.4	20.8
HCM Lane LOS	D	C	C	C
HCM 95th-tile Q	6.3	1.9	4.6	4.3

HCM 7th Signalized Intersection Summary

60: 800 West & 1500 South

02/05/2026



Movement	EBL	EBT	EBR	WBL	WBT	WBR	NBL	NBT	NBR	SBL	SBT	SBR
Lane Configurations	↖	↗		↖	↗		↖	↗		↖	↗	
Traffic Volume (veh/h)	68	226	54	36	196	50	29	95	53	44	55	51
Future Volume (veh/h)	68	226	54	36	196	50	29	95	53	44	55	51
Initial Q (Qb), veh	0	0	0	0	0	0	0	0	0	0	0	0
Lane Width Adj.	1.00	1.00	1.00	1.00	1.00	1.00	1.00	1.00	1.00	1.00	1.00	1.00
Ped-Bike Adj(A_pbT)	1.00		1.00	1.00		1.00	1.00		1.00	1.00		1.00
Parking Bus, Adj	1.00	1.00	1.00	1.00	1.00	1.00	1.00	1.00	1.00	1.00	1.00	1.00
Work Zone On Approach		No			No			No			No	
Adj Sat Flow, veh/h/ln	1870	1885	1841	1856	1856	1870	1900	1870	1900	1900	1841	1900
Adj Flow Rate, veh/h	91	301	72	47	255	65	41	134	75	68	85	78
Peak Hour Factor	0.75	0.75	0.75	0.77	0.77	0.77	0.71	0.71	0.71	0.65	0.65	0.65
Percent Heavy Veh, %	2	1	4	3	3	2	0	2	0	0	4	0
Cap, veh/h	538	553	132	499	537	137	522	304	170	487	239	219
Arrive On Green	0.38	0.38	0.38	0.38	0.38	0.38	0.27	0.27	0.27	0.27	0.27	0.27
Sat Flow, veh/h	1060	1470	352	1001	1426	364	1242	1126	630	1191	884	811
Grp Volume(v), veh/h	91	0	373	47	0	320	41	0	209	68	0	163
Grp Sat Flow(s),veh/h/ln1060	0	1822	1001	0	1790	1242	0	1757	1191	0	1695	
Q Serve(g_s), s	1.8	0.0	4.1	1.0	0.0	3.5	0.7	0.0	2.5	1.3	0.0	2.0
Cycle Q Clear(g_c), s	5.3	0.0	4.1	5.1	0.0	3.5	2.7	0.0	2.5	3.8	0.0	2.0
Prop In Lane	1.00		0.19	1.00		0.20	1.00		0.36	1.00		0.48
Lane Grp Cap(c), veh/h	538	0	686	499	0	674	522	0	474	487	0	457
V/C Ratio(X)	0.17	0.00	0.54	0.09	0.00	0.47	0.08	0.00	0.44	0.14	0.00	0.36
Avail Cap(c_a), veh/h	1034	0	1539	968	0	1512	1382	0	1691	1312	0	1632
HCM Platoon Ratio	1.00	1.00	1.00	1.00	1.00	1.00	1.00	1.00	1.00	1.00	1.00	1.00
Upstream Filter(l)	1.00	0.00	1.00	1.00	0.00	1.00	1.00	0.00	1.00	1.00	0.00	1.00
Uniform Delay (d), s/veh	8.0	0.0	6.2	8.2	0.0	6.0	8.6	0.0	7.7	9.3	0.0	7.5
Incr Delay (d2), s/veh	0.1	0.0	0.7	0.1	0.0	0.5	0.1	0.0	0.6	0.1	0.0	0.5
Initial Q Delay(d3), s/veh	0.0	0.0	0.0	0.0	0.0	0.0	0.0	0.0	0.0	0.0	0.0	0.0
%ile BackOfQ(95%),veh/ln0.5	0.0	1.5	0.3	0.0	1.2	0.2	0.0	1.1	0.4	0.0	0.8	
Unsig. Movement Delay, s/veh												
LnGrp Delay(d), s/veh	8.2	0.0	6.9	8.3	0.0	6.5	8.6	0.0	8.3	9.4	0.0	8.0
LnGrp LOS	A		A	A		A	A		A	A		A
Approach Vol, veh/h		464			367			250			231	
Approach Delay, s/veh		7.1			6.8			8.4			8.4	
Approach LOS		A			A			A			A	
Timer - Assigned Phs		2		4		6		8				
Phs Duration (G+Y+Rc), s		11.4		14.1		11.4		14.1				
Change Period (Y+Rc), s		4.5		4.5		4.5		4.5				
Max Green Setting (Gmax), s		24.5		21.5		24.5		21.5				
Max Q Clear Time (g_c+1), s		4.7		7.3		5.8		7.1				
Green Ext Time (p_c), s		1.3		2.3		1.1		1.8				
Intersection Summary												
HCM 7th Control Delay, s/veh				7.5								
HCM 7th LOS				A								

Intersection												
Int Delay, s/veh	3.4											
Movement	EBL	EBT	EBR	WBL	WBT	WBR	NBL	NBT	NBR	SBL	SBT	SBR
Lane Configurations		↕			↕			↕			↕	
Traffic Vol, veh/h	1	14	2	43	5	8	0	22	66	18	27	4
Future Vol, veh/h	1	14	2	43	5	8	0	22	66	18	27	4
Conflicting Peds, #/hr	0	0	0	0	0	0	0	0	0	0	0	0
Sign Control	Stop	Stop	Stop	Stop	Stop	Stop	Free	Free	Free	Free	Free	Free
RT Channelized	-	-	None	-	-	None	-	-	None	-	-	None
Storage Length	-	-	-	-	-	-	-	-	-	-	-	-
Veh in Median Storage, #	-	0	-	-	0	-	-	0	-	-	0	-
Grade, %	-	0	-	-	0	-	-	0	-	-	0	-
Peak Hour Factor	71	71	71	78	78	78	45	45	45	68	68	68
Heavy Vehicles, %	0	7	100	0	0	13	0	5	2	6	4	25
Mvmt Flow	1	20	3	55	6	10	0	49	147	26	40	6

Major/Minor	Minor2		Minor1		Major1			Major2				
Conflicting Flow All	148	291	43	225	221	122	46	0	0	196	0	0
Stage 1	96	96	-	122	122	-	-	-	-	-	-	-
Stage 2	52	196	-	103	99	-	-	-	-	-	-	-
Critical Hdwy	7.1	6.57	7.2	7.1	6.5	6.33	4.1	-	-	4.16	-	-
Critical Hdwy Stg 1	6.1	5.57	-	6.1	5.5	-	-	-	-	-	-	-
Critical Hdwy Stg 2	6.1	5.57	-	6.1	5.5	-	-	-	-	-	-	-
Follow-up Hdwy	3.5	4.063	4.2	3.5	4	3.417	2.2	-	-	2.254	-	-
Pot Cap-1 Maneuver	825	611	807	735	681	900	1575	-	-	1354	-	-
Stage 1	916	806	-	887	799	-	-	-	-	-	-	-
Stage 2	966	730	-	908	817	-	-	-	-	-	-	-
Platoon blocked, %								-	-	-	-	-
Mov Cap-1 Maneuver	792	599	807	695	668	900	1575	-	-	1354	-	-
Mov Cap-2 Maneuver	792	599	-	695	668	-	-	-	-	-	-	-
Stage 1	898	790	-	887	799	-	-	-	-	-	-	-
Stage 2	947	730	-	865	801	-	-	-	-	-	-	-

Approach	EB		WB		NB		SB	
HCM Ctrl Dly, s/v	10.97		10.59		0		2.83	
HCM LOS	B		B					

Minor Lane/Major Mvmt	NBL	NBT	NBR	EBLn1	WBLn1	SBL	SBT	SBR
Capacity (veh/h)	1575	-	-	627	715	645	-	-
HCM Lane V/C Ratio	-	-	-	0.038	0.1	0.02	-	-
HCM Ctrl Dly (s/v)	0	-	-	11	10.6	7.7	0	-
HCM Lane LOS	A	-	-	B	B	A	A	-
HCM 95th %tile Q(veh)	0	-	-	0.1	0.3	0.1	-	-

Intersection	
Intersection Delay, s/veh	7.4
Intersection LOS	A

Movement	EBL	EBT	EBR	WBL	WBT	WBR	NBL	NBT	NBR	SBL	SBT	SBR
Lane Configurations		↕			↕			↕			↕	
Traffic Vol, veh/h	0	16	3	25	14	4	13	0	50	6	1	0
Future Vol, veh/h	0	16	3	25	14	4	13	0	50	6	1	0
Peak Hour Factor	0.79	0.79	0.79	0.60	0.60	0.60	0.68	0.68	0.68	0.88	0.88	0.88
Heavy Vehicles, %	0	6	33	8	0	0	8	0	0	0	0	0
Mvmt Flow	0	20	4	42	23	7	19	0	74	7	1	0
Number of Lanes	0	1	0	0	1	0	0	1	0	0	1	0

Approach	EB	WB	NB	SB
Opposing Approach	WB	EB	SB	NB
Opposing Lanes	1	1	1	1
Conflicting Approach Left	SB	NB	EB	WB
Conflicting Lanes Left	1	1	1	1
Conflicting Approach Right	NB	SB	WB	EB
Conflicting Lanes Right	1	1	1	1
HCM Control Delay, s/veh	7.3	7.7	7.2	7.4
HCM LOS	A	A	A	A

Lane	NBLn1	EBLn1	WBLn1	SBLn1
Vol Left, %	21%	0%	58%	86%
Vol Thru, %	0%	84%	33%	14%
Vol Right, %	79%	16%	9%	0%
Sign Control	Stop	Stop	Stop	Stop
Traffic Vol by Lane	63	19	43	7
LT Vol	13	0	25	6
Through Vol	0	16	14	1
RT Vol	50	3	4	0
Lane Flow Rate	93	24	72	8
Geometry Grp	1	1	1	1
Degree of Util (X)	0.097	0.028	0.085	0.01
Departure Headway (Hd)	3.772	4.137	4.289	4.309
Convergence, Y/N	Yes	Yes	Yes	Yes
Cap	941	859	832	823
Service Time	1.829	2.191	2.331	2.377
HCM Lane V/C Ratio	0.099	0.028	0.087	0.01
HCM Control Delay, s/veh	7.2	7.3	7.7	7.4
HCM Lane LOS	A	A	A	A
HCM 95th-tile Q	0.3	0.1	0.3	0

Intersection												
Int Delay, s/veh	5.1											
Movement	EBL	EBT	EBR	WBL	WBT	WBR	NBL	NBT	NBR	SBL	SBT	SBR
Lane Configurations												
Traffic Vol, veh/h	144	0	92	0	0	0	51	54	2	1	165	214
Future Vol, veh/h	144	0	92	0	0	0	51	54	2	1	165	214
Conflicting Peds, #/hr	0	0	0	0	0	0	0	0	0	0	0	0
Sign Control	Stop	Stop	Stop	Stop	Stop	Stop	Free	Free	Free	Free	Free	Free
RT Channelized	-	-	None	-	-	None	-	-	None	-	-	None
Storage Length	100	-	-	-	-	-	-	-	-	-	-	-
Veh in Median Storage, #	-	0	-	-	0	-	-	0	-	-	0	-
Grade, %	-	0	-	-	0	-	-	0	-	-	0	-
Peak Hour Factor	92	92	92	92	92	92	92	92	92	92	92	92
Heavy Vehicles, %	2	2	2	2	2	2	2	2	2	2	2	2
Mvmt Flow	157	0	100	0	0	0	55	59	2	1	179	233

Major/Minor	Minor2		Minor1		Major1		Major2					
Conflicting Flow All	467	470	296	352	585	60	412	0	0	61	0	0
Stage 1	298	298	-	171	171	-	-	-	-	-	-	-
Stage 2	170	172	-	182	414	-	-	-	-	-	-	-
Critical Hdwy	7.12	6.52	6.22	7.12	6.52	6.22	4.12	-	-	4.12	-	-
Critical Hdwy Stg 1	6.12	5.52	-	6.12	5.52	-	-	-	-	-	-	-
Critical Hdwy Stg 2	6.12	5.52	-	6.12	5.52	-	-	-	-	-	-	-
Follow-up Hdwy	3.518	4.018	3.318	3.518	4.018	3.318	2.218	-	-	2.218	-	-
Pot Cap-1 Maneuver	506	492	744	603	423	1006	1147	-	-	1542	-	-
Stage 1	711	667	-	831	757	-	-	-	-	-	-	-
Stage 2	832	757	-	820	593	-	-	-	-	-	-	-
Platoon blocked, %								-	-	-	-	-
Mov Cap-1 Maneuver	480	467	744	495	401	1006	1147	-	-	1542	-	-
Mov Cap-2 Maneuver	480	467	-	495	401	-	-	-	-	-	-	-
Stage 1	710	666	-	790	720	-	-	-	-	-	-	-
Stage 2	791	719	-	709	592	-	-	-	-	-	-	-

Approach	EB	WB	NB	SB
HCM Ctrl Dly, s/v	13.94	0	3.96	0.02
HCM LOS	B	A		

Minor Lane/Major Mvmt	NBL	NBT	NBR	EBLn1	EBLn2	WBLn1	SBL	SBT	SBR
Capacity (veh/h)	852	-	-	480	744	-	4	-	-
HCM Lane V/C Ratio	0.048	-	-	0.326	0.134	-	0.001	-	-
HCM Ctrl Dly (s/v)	8.3	0	-	16.1	10.6	0	7.3	0	-
HCM Lane LOS	A	A	-	C	B	A	A	A	-
HCM 95th %tile Q(veh)	0.2	-	-	1.4	0.5	-	0	-	-

Intersection						
Int Delay, s/veh	5					
Movement	SEL	SER	NEL	NET	SWT	SWR
Lane Configurations						
Traffic Vol, veh/h	4	66	53	52	36	4
Future Vol, veh/h	4	66	53	52	36	4
Conflicting Peds, #/hr	0	0	0	0	0	0
Sign Control	Stop	Stop	Free	Free	Free	Free
RT Channelized	-	None	-	None	-	None
Storage Length	0	-	0	-	-	-
Veh in Median Storage, #	0	-	-	0	0	-
Grade, %	0	-	-	0	0	-
Peak Hour Factor	63	63	75	75	67	67
Heavy Vehicles, %	25	2	0	0	0	25
Mvmt Flow	6	105	71	69	54	6

Major/Minor	Minor2	Major1	Major2			
Conflicting Flow All	267	57	60	0	-	0
Stage 1	57	-	-	-	-	-
Stage 2	211	-	-	-	-	-
Critical Hdwy	6.65	6.22	4.1	-	-	-
Critical Hdwy Stg 1	5.65	-	-	-	-	-
Critical Hdwy Stg 2	5.65	-	-	-	-	-
Follow-up Hdwy	3.725	3.318	2.2	-	-	-
Pot Cap-1 Maneuver	675	1010	1557	-	-	-
Stage 1	910	-	-	-	-	-
Stage 2	773	-	-	-	-	-
Platoon blocked, %				-	-	-
Mov Cap-1 Maneuver	644	1010	1557	-	-	-
Mov Cap-2 Maneuver	644	-	-	-	-	-
Stage 1	869	-	-	-	-	-
Stage 2	773	-	-	-	-	-

Approach	SE	NE	SW
HCM Ctrl Dly, s/v	9.15	3.75	0
HCM LOS	A		

Minor Lane/Major Mvmt	NEL	NET SELn1	SWT	SWR
Capacity (veh/h)	1557	-	978	-
HCM Lane V/C Ratio	0.045	-	0.114	-
HCM Ctrl Dly (s/v)	7.4	-	9.2	-
HCM Lane LOS	A	-	A	-
HCM 95th %tile Q(veh)	0.1	-	0.4	-

HCM Unsignalized Intersection Capacity Analysis
 110: Mountain View Blvd & 2260 South

02/05/2026

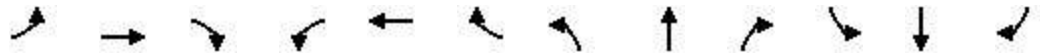

Movement	EBL	EBT	EBR	WBL	WBT	WBR	NBL	NBT	NBR	SBL	SBT	SBR
Lane Configurations		↕			↕			↕			↕	
Sign Control		Yield			Yield			Yield			Yield	
Traffic Volume (vph)	5	6	0	2	1	7	0	5	5	7	3	3
Future Volume (vph)	5	6	0	2	1	7	0	5	5	7	3	3
Peak Hour Factor	0.55	0.55	0.55	0.42	0.42	0.42	0.50	0.50	0.50	0.33	0.33	0.33
Hourly flow rate (vph)	9	11	0	5	2	17	0	10	10	21	9	9

Direction, Lane #	EB 1	WB 1	NB 1	SB 1
Volume Total (vph)	20	24	20	39
Volume Left (vph)	9	5	0	21
Volume Right (vph)	0	17	10	9
Hadj (s)	0.56	-0.04	-0.13	0.23
Departure Headway (s)	4.6	4.0	3.9	4.3
Degree Utilization, x	0.03	0.03	0.02	0.05
Capacity (veh/h)	765	878	896	833
Control Delay (s/veh)	7.7	7.1	7.0	7.5
Approach Delay (s/veh)	7.7	7.1	7.0	7.5
Approach LOS	A	A	A	A

Intersection Summary			
Delay		7.3	
Level of Service		A	
Intersection Capacity Utilization	16.8%		ICU Level of Service A
Analysis Period (min)		15	

Existing Condition - PM

Intersection						
Int Delay, s/veh	1					
Movement	WBL	WBR	NBT	NBR	SBL	SBT
Lane Configurations	W		T			T
Traffic Vol, veh/h	10	14	158	11	13	177
Future Vol, veh/h	10	14	158	11	13	177
Conflicting Peds, #/hr	0	0	0	0	0	0
Sign Control	Stop	Stop	Free	Free	Free	Free
RT Channelized	-	None	-	None	-	None
Storage Length	0	-	-	-	-	-
Veh in Median Storage, #	0	-	0	-	-	0
Grade, %	0	-	0	-	-	0
Peak Hour Factor	75	75	81	81	91	91
Heavy Vehicles, %	10	7	2	0	8	0
Mvmt Flow	13	19	195	14	14	195

Major/Minor	Minor1	Major1	Major2		
Conflicting Flow All	425	202	0	0	209
Stage 1	202	-	-	-	-
Stage 2	223	-	-	-	-
Critical Hdwy	6.5	6.27	-	-	4.18
Critical Hdwy Stg 1	5.5	-	-	-	-
Critical Hdwy Stg 2	5.5	-	-	-	-
Follow-up Hdwy	3.59	3.363	-	-	2.272
Pot Cap-1 Maneuver	571	826	-	-	1327
Stage 1	813	-	-	-	-
Stage 2	795	-	-	-	-
Platoon blocked, %			-	-	-
Mov Cap-1 Maneuver	564	826	-	-	1327
Mov Cap-2 Maneuver	564	-	-	-	-
Stage 1	813	-	-	-	-
Stage 2	786	-	-	-	-

Approach	WB	NB	SB
HCM Ctrl Dly, s/v	10.45	0	0.53
HCM LOS	B		

Minor Lane/Major Mvmt	NBT	NBRWBLn1	SBL	SBT
Capacity (veh/h)	-	-	692	123
HCM Lane V/C Ratio	-	-	0.046	0.011
HCM Ctrl Dly (s/v)	-	-	10.5	7.7
HCM Lane LOS	-	-	B	A
HCM 95th %tile Q(veh)	-	-	0.1	0

Intersection				
Intersection Delay, s/veh	3.8			
Intersection LOS	A			
Approach	EB	WB	NB	SB
Entry Lanes	1	1	1	1
Conflicting Circle Lanes	1	1	1	1
Adj Approach Flow, veh/h	35	228	55	62
Demand Flow Rate, veh/h	36	232	57	65
Vehicles Circulating, veh/h	119	3	90	103
Vehicles Exiting, veh/h	49	144	65	132
Ped Vol Crossing Leg, #/h	0	0	0	0
Ped Cap Adj	1.000	1.000	1.000	1.000
Approach Delay, s/veh	3.3	4.0	3.3	3.5
Approach LOS	A	A	A	A
Lane	Left	Left	Left	Left
Designated Moves	LTR	LTR	LTR	LTR
Assumed Moves	LTR	LTR	LTR	LTR
RT Channelized				
Lane Util	1.000	1.000	1.000	1.000
Follow-Up Headway, s	2.609	2.609	2.609	2.609
Critical Headway, s	4.976	4.976	4.976	4.976
A (Intercept)	1380	1380	1380	1380
B (Slope)	1.02e-3	1.02e-3	1.02e-3	1.02e-3
Entry Flow, veh/h	36	232	57	65
Cap Entry Lane, veh/h	1222	1376	1259	1242
Entry HV Adj Factor	0.960	0.984	0.965	0.954
Flow Entry, veh/h	35	228	55	62
Cap Entry, veh/h	1174	1354	1215	1185
V/C Ratio	0.029	0.169	0.045	0.052
Control Delay, s/veh	3.3	4.0	3.3	3.5
LOS	A	A	A	A
95th %tile Queue, veh	0	1	0	0

Intersection						
Int Delay, s/veh	1.5					
Movement	EBT	EBR	WBL	WBT	NBL	NBR
Lane Configurations						
Traffic Vol, veh/h	211	63	22	202	34	11
Future Vol, veh/h	211	63	22	202	34	11
Conflicting Peds, #/hr	0	0	0	0	0	0
Sign Control	Free	Free	Free	Free	Stop	Stop
RT Channelized	-	None	-	None	-	None
Storage Length	-	-	-	-	0	-
Veh in Median Storage, #	0	-	-	0	0	-
Grade, %	0	-	-	0	0	-
Peak Hour Factor	88	88	89	89	75	75
Heavy Vehicles, %	2	0	5	1	0	0
Mvmt Flow	240	72	25	227	45	15

Major/Minor	Major1	Major2	Minor1		
Conflicting Flow All	0	0	311	0	552 276
Stage 1	-	-	-	-	276 -
Stage 2	-	-	-	-	276 -
Critical Hdwy	-	-	4.15	-	6.4 6.2
Critical Hdwy Stg 1	-	-	-	-	5.4 -
Critical Hdwy Stg 2	-	-	-	-	5.4 -
Follow-up Hdwy	-	-	2.245	-	3.5 3.3
Pot Cap-1 Maneuver	-	-	1232	-	498 768
Stage 1	-	-	-	-	776 -
Stage 2	-	-	-	-	775 -
Platoon blocked, %	-	-	-	-	-
Mov Cap-1 Maneuver	-	-	1232	-	487 768
Mov Cap-2 Maneuver	-	-	-	-	487 -
Stage 1	-	-	-	-	776 -
Stage 2	-	-	-	-	757 -

Approach	EB	WB	NB
HCM Ctrl Dly, s/v	0	0.78	12.58
HCM LOS			B

Minor Lane/Major Mvmt	NBLn1	EBT	EBR	WBL	WBT
Capacity (veh/h)	535	-	-	177	-
HCM Lane V/C Ratio	0.112	-	-	0.02	-
HCM Ctrl Dly (s/v)	12.6	-	-	8	0
HCM Lane LOS	B	-	-	A	A
HCM 95th %tile Q(veh)	0.4	-	-	0.1	-

Intersection												
Int Delay, s/veh	1.6											
Movement	EBL	EBT	EBR	WBL	WBT	WBR	NBL	NBT	NBR	SBL	SBT	SBR
Lane Configurations		↕			↕			↕			↕	
Traffic Vol, veh/h	24	208	2	10	237	10	0	0	8	13	0	11
Future Vol, veh/h	24	208	2	10	237	10	0	0	8	13	0	11
Conflicting Peds, #/hr	0	0	0	0	0	0	0	0	0	0	0	0
Sign Control	Free	Free	Free	Free	Free	Free	Stop	Stop	Stop	Stop	Stop	Stop
RT Channelized	-	-	None	-	-	None	-	-	None	-	-	None
Storage Length	-	-	-	-	-	-	-	-	-	-	-	-
Veh in Median Storage, #	-	0	-	-	0	-	-	0	-	-	0	-
Grade, %	-	0	-	-	0	-	-	0	-	-	0	-
Peak Hour Factor	86	86	86	90	90	90	40	40	40	60	60	60
Heavy Vehicles, %	4	2	0	0	0	0	0	0	0	0	0	0
Mvmt Flow	28	242	2	11	263	11	0	0	20	22	0	18

Major/Minor	Major1			Major2			Minor1			Minor2		
Conflicting Flow All	274	0	0	244	0	0	584	596	243	589	591	269
Stage 1	-	-	-	-	-	-	299	299	-	291	291	-
Stage 2	-	-	-	-	-	-	286	297	-	298	300	-
Critical Hdwy	4.14	-	-	4.1	-	-	7.1	6.5	6.2	7.1	6.5	6.2
Critical Hdwy Stg 1	-	-	-	-	-	-	6.1	5.5	-	6.1	5.5	-
Critical Hdwy Stg 2	-	-	-	-	-	-	6.1	5.5	-	6.1	5.5	-
Follow-up Hdwy	2.236	-	-	2.2	-	-	3.5	4	3.3	3.5	4	3.3
Pot Cap-1 Maneuver	1277	-	-	1334	-	-	426	420	801	423	422	775
Stage 1	-	-	-	-	-	-	714	670	-	721	675	-
Stage 2	-	-	-	-	-	-	726	671	-	715	669	-
Platoon blocked, %		-	-		-	-						
Mov Cap-1 Maneuver	1277	-	-	1334	-	-	401	405	801	398	408	775
Mov Cap-2 Maneuver	-	-	-	-	-	-	401	405	-	398	408	-
Stage 1	-	-	-	-	-	-	696	653	-	714	669	-
Stage 2	-	-	-	-	-	-	702	665	-	680	652	-

Approach	EB			WB			NB			SB		
HCM Ctrl Dly, s/v	0.81			0.3			9.61			12.62		
HCM LOS							A			B		

Minor Lane/Major Mvmt	NBLn1	EBL	EBT	EBR	WBL	WBT	WBR	SBLn1
Capacity (veh/h)	801	184	-	-	69	-	-	512
HCM Lane V/C Ratio	0.025	0.022	-	-	0.008	-	-	0.078
HCM Ctrl Dly (s/v)	9.6	7.9	0	-	7.7	0	-	12.6
HCM Lane LOS	A	A	A	-	A	A	-	B
HCM 95th %tile Q(veh)	0.1	0.1	-	-	0	-	-	0.3

Intersection	
Intersection Delay, s/veh	26.8
Intersection LOS	D

Movement	EBL	EBT	EBR	WBL	WBT	WBR	NBL	NBT	NBR	SBL	SBT	SBR
Lane Configurations		↕			↕			↕			↕	
Traffic Vol, veh/h	31	177	27	81	227	50	25	183	78	37	93	67
Future Vol, veh/h	31	177	27	81	227	50	25	183	78	37	93	67
Peak Hour Factor	0.83	0.83	0.83	0.77	0.77	0.77	0.91	0.91	0.91	0.83	0.83	0.83
Heavy Vehicles, %	7	2	0	3	0	4	0	1	5	3	3	3
Mvmt Flow	37	213	33	105	295	65	27	201	86	45	112	81
Number of Lanes	0	1	0	0	1	0	0	1	0	0	1	0

Approach	EB	WB	NB	SB
Opposing Approach	WB	EB	SB	NB
Opposing Lanes	1	1	1	1
Conflicting Approach Left	SB	NB	EB	WB
Conflicting Lanes Left	1	1	1	1
Conflicting Approach Right	NB	SB	WB	EB
Conflicting Lanes Right	1	1	1	1
HCM Control Delay, s/veh	19.6	39.7	21.2	17.3
HCM LOS	C	E	C	C

Lane	NBLn1	EBLn1	WBLn1	SBLn1
Vol Left, %	9%	13%	23%	19%
Vol Thru, %	64%	75%	63%	47%
Vol Right, %	27%	11%	14%	34%
Sign Control	Stop	Stop	Stop	Stop
Traffic Vol by Lane	286	235	358	197
LT Vol	25	31	81	37
Through Vol	183	177	227	93
RT Vol	78	27	50	67
Lane Flow Rate	314	283	465	237
Geometry Grp	1	1	1	1
Degree of Util (X)	0.62	0.571	0.869	0.487
Departure Headway (Hd)	7.101	7.258	6.726	7.382
Convergence, Y/N	Yes	Yes	Yes	Yes
Cap	506	495	539	487
Service Time	5.172	5.335	4.791	5.461
HCM Lane V/C Ratio	0.621	0.572	0.863	0.487
HCM Control Delay, s/veh	21.2	19.6	39.7	17.3
HCM Lane LOS	C	C	E	C
HCM 95th-tile Q	4.2	3.5	9.5	2.6

HCM 7th Signalized Intersection Summary

60: 800 West & 1500 South

02/05/2026



Movement	EBL	EBT	EBR	WBL	WBT	WBR	NBL	NBT	NBR	SBL	SBT	SBR
Lane Configurations												
Traffic Volume (veh/h)	52	233	44	78	239	52	43	82	86	55	76	56
Future Volume (veh/h)	52	233	44	78	239	52	43	82	86	55	76	56
Initial Q (Qb), veh	0	0	0	0	0	0	0	0	0	0	0	0
Lane Width Adj.	1.00	1.00	1.00	1.00	1.00	1.00	1.00	1.00	1.00	1.00	1.00	1.00
Ped-Bike Adj(A_pbT)	1.00		1.00	1.00		1.00	1.00		1.00	1.00		1.00
Parking Bus, Adj	1.00	1.00	1.00	1.00	1.00	1.00	1.00	1.00	1.00	1.00	1.00	1.00
Work Zone On Approach		No		No		No		No		No		No
Adj Sat Flow, veh/h/ln	1900	1885	1900	1900	1870	1870	1870	1900	1885	1900	1900	1841
Adj Flow Rate, veh/h	66	295	56	99	303	66	47	90	95	106	146	108
Peak Hour Factor	0.79	0.79	0.79	0.79	0.79	0.79	0.91	0.91	0.91	0.52	0.52	0.52
Percent Heavy Veh, %	0	1	0	0	2	2	2	0	1	0	0	4
Cap, veh/h	488	586	111	504	566	123	458	250	264	517	300	222
Arrive On Green	0.38	0.38	0.38	0.38	0.38	0.38	0.30	0.30	0.30	0.30	0.30	0.30
Sat Flow, veh/h	1029	1540	292	1046	1488	324	1126	846	893	1218	1014	750
Grp Volume(v), veh/h	66	0	351	99	0	369	47	0	185	106	0	254
Grp Sat Flow(s),veh/h/ln	1029	0	1833	1046	0	1812	1126	0	1739	1218	0	1765
Q Serve(g_s), s	1.5	0.0	4.1	2.2	0.0	4.4	1.0	0.0	2.3	2.1	0.0	3.3
Cycle Q Clear(g_c), s	5.9	0.0	4.1	6.3	0.0	4.4	4.3	0.0	2.3	4.4	0.0	3.3
Prop In Lane	1.00		0.16	1.00		0.18	1.00		0.51	1.00		0.43
Lane Grp Cap(c), veh/h	488	0	697	504	0	689	458	0	514	517	0	521
V/C Ratio(X)	0.14	0.00	0.50	0.20	0.00	0.54	0.10	0.00	0.36	0.21	0.00	0.49
Avail Cap(c_a), veh/h	894	0	1420	917	0	1404	1120	0	1536	1233	0	1558
HCM Platoon Ratio	1.00	1.00	1.00	1.00	1.00	1.00	1.00	1.00	1.00	1.00	1.00	1.00
Upstream Filter(l)	1.00	0.00	1.00	1.00	0.00	1.00	1.00	0.00	1.00	1.00	0.00	1.00
Uniform Delay (d), s/veh	9.0	0.0	6.6	9.0	0.0	6.7	9.8	0.0	7.7	9.5	0.0	8.0
Incr Delay (d2), s/veh	0.1	0.0	0.6	0.2	0.0	0.6	0.1	0.0	0.4	0.2	0.0	0.7
Initial Q Delay(d3), s/veh	0.0	0.0	0.0	0.0	0.0	0.0	0.0	0.0	0.0	0.0	0.0	0.0
%ile BackOfQ(95%),veh/ln	0.4	0.0	1.7	0.6	0.0	1.8	0.3	0.0	1.1	0.7	0.0	1.5
Unsig. Movement Delay, s/veh												
LnGrp Delay(d), s/veh	9.1	0.0	7.2	9.2	0.0	7.3	9.9	0.0	8.1	9.6	0.0	8.8
LnGrp LOS	A		A	A		A	A		A	A		A
Approach Vol, veh/h		417			468			232			360	
Approach Delay, s/veh		7.5			7.7			8.5			9.0	
Approach LOS		A			A			A			A	
Timer - Assigned Phs		2		4		6		8				
Phs Duration (G+Y+Rc), s		12.7		15.1		12.7		15.1				
Change Period (Y+Rc), s		4.5		4.5		4.5		4.5				
Max Green Setting (Gmax), s		24.5		21.5		24.5		21.5				
Max Q Clear Time (g_c+1), s		6.3		7.9		6.4		8.3				
Green Ext Time (p_c), s		1.1		2.0		1.8		2.3				
Intersection Summary												
HCM 7th Control Delay, s/veh			8.1									
HCM 7th LOS			A									

Intersection												
Int Delay, s/veh	6.3											
Movement	EBL	EBT	EBR	WBL	WBT	WBR	NBL	NBT	NBR	SBL	SBT	SBR
Lane Configurations		↕			↕			↕			↕	
Traffic Vol, veh/h	0	13	0	36	16	25	1	8	29	12	2	1
Future Vol, veh/h	0	13	0	36	16	25	1	8	29	12	2	1
Conflicting Peds, #/hr	0	0	0	0	0	0	0	0	0	0	0	0
Sign Control	Stop	Stop	Stop	Stop	Stop	Stop	Free	Free	Free	Free	Free	Free
RT Channelized	-	-	None	-	-	None	-	-	None	-	-	None
Storage Length	-	-	-	-	-	-	-	-	-	-	-	-
Veh in Median Storage, #	-	0	-	-	0	-	-	0	-	-	0	-
Grade, %	-	0	-	-	0	-	-	0	-	-	0	-
Peak Hour Factor	65	65	65	66	66	66	50	50	50	54	54	54
Heavy Vehicles, %	0	0	0	0	6	4	0	0	0	0	50	0
Mvmt Flow	0	20	0	55	24	38	2	16	58	22	4	2

Major/Minor	Minor2		Minor1		Major1			Major2				
Conflicting Flow All	81	127	5	107	99	45	6	0	0	74	0	0
Stage 1	49	49	-	49	49	-	-	-	-	-	-	-
Stage 2	32	78	-	58	50	-	-	-	-	-	-	-
Critical Hdwy	7.1	6.5	6.2	7.1	6.56	6.24	4.1	-	-	4.1	-	-
Critical Hdwy Stg 1	6.1	5.5	-	6.1	5.56	-	-	-	-	-	-	-
Critical Hdwy Stg 2	6.1	5.5	-	6.1	5.56	-	-	-	-	-	-	-
Follow-up Hdwy	3.5	4	3.3	3.5	4.054	3.336	2.2	-	-	2.2	-	-
Pot Cap-1 Maneuver	911	767	1085	877	784	1019	1629	-	-	1538	-	-
Stage 1	969	858	-	969	846	-	-	-	-	-	-	-
Stage 2	989	834	-	959	845	-	-	-	-	-	-	-
Platoon blocked, %								-	-	-	-	-
Mov Cap-1 Maneuver	837	755	1085	840	771	1019	1629	-	-	1538	-	-
Mov Cap-2 Maneuver	837	755	-	840	771	-	-	-	-	-	-	-
Stage 1	955	846	-	968	845	-	-	-	-	-	-	-
Stage 2	924	833	-	922	833	-	-	-	-	-	-	-

Approach	EB		WB		NB		SB	
HCM Ctrl Dly, s/v	9.9		9.75		0.19		5.9	
HCM LOS	A		A					

Minor Lane/Major Mvmt	NBL	NBT	NBR	EBLn1	WBLn1	SBL	SBT	SBR
Capacity (veh/h)	41	-	-	755	874	1350	-	-
HCM Lane V/C Ratio	0.001	-	-	0.026	0.134	0.014	-	-
HCM Ctrl Dly (s/v)	7.2	0	-	9.9	9.8	7.4	0	-
HCM Lane LOS	A	A	-	A	A	A	A	-
HCM 95th %tile Q(veh)	0	-	-	0.1	0.5	0	-	-

Intersection	
Intersection Delay, s/veh	7.5
Intersection LOS	A

Movement	EBL	EBT	EBR	WBL	WBT	WBR	NBL	NBT	NBR	SBL	SBT	SBR
Lane Configurations		↕			↕			↕			↕	
Traffic Vol, veh/h	2	25	12	40	30	11	10	4	49	7	3	2
Future Vol, veh/h	2	25	12	40	30	11	10	4	49	7	3	2
Peak Hour Factor	0.70	0.70	0.70	0.78	0.78	0.78	0.88	0.88	0.88	0.43	0.43	0.43
Heavy Vehicles, %	0	0	0	0	3	0	0	0	0	0	0	0
Mvmt Flow	3	36	17	51	38	14	11	5	56	16	7	5
Number of Lanes	0	1	0	0	1	0	0	1	0	0	1	0

Approach	EB	WB	NB	SB
Opposing Approach	WB	EB	SB	NB
Opposing Lanes	1	1	1	1
Conflicting Approach Left	SB	NB	EB	WB
Conflicting Lanes Left	1	1	1	1
Conflicting Approach Right	NB	SB	WB	EB
Conflicting Lanes Right	1	1	1	1
HCM Control Delay, s/veh	7.3	7.7	7.2	7.5
HCM LOS	A	A	A	A

Lane	NBLn1	EBLn1	WBLn1	SBLn1
Vol Left, %	16%	5%	49%	58%
Vol Thru, %	6%	64%	37%	25%
Vol Right, %	78%	31%	14%	17%
Sign Control	Stop	Stop	Stop	Stop
Traffic Vol by Lane	63	39	81	12
LT Vol	10	2	40	7
Through Vol	4	25	30	3
RT Vol	49	12	11	2
Lane Flow Rate	72	56	104	28
Geometry Grp	1	1	1	1
Degree of Util (X)	0.075	0.062	0.119	0.033
Departure Headway (Hd)	3.762	3.979	4.134	4.249
Convergence, Y/N	Yes	Yes	Yes	Yes
Cap	938	892	862	831
Service Time	1.844	2.04	2.182	2.335
HCM Lane V/C Ratio	0.077	0.063	0.121	0.034
HCM Control Delay, s/veh	7.2	7.3	7.7	7.5
HCM Lane LOS	A	A	A	A
HCM 95th-tile Q	0.2	0.2	0.4	0.1

Intersection												
Int Delay, s/veh	2											
Movement	EBL	EBT	EBR	WBL	WBT	WBR	NBL	NBT	NBR	SBL	SBT	SBR
Lane Configurations												
Traffic Vol, veh/h	54	0	15	0	0	0	5	217	0	0	86	25
Future Vol, veh/h	54	0	15	0	0	0	5	217	0	0	86	25
Conflicting Peds, #/hr	0	0	0	0	0	0	0	0	0	0	0	0
Sign Control	Stop	Stop	Stop	Stop	Stop	Stop	Free	Free	Free	Free	Free	Free
RT Channelized	-	-	None	-	-	None	-	-	None	-	-	None
Storage Length	100	-	-	-	-	-	-	-	-	-	-	-
Veh in Median Storage, #	-	0	-	-	0	-	-	0	-	-	0	-
Grade, %	-	0	-	-	0	-	-	0	-	-	0	-
Peak Hour Factor	92	92	92	92	92	92	92	92	92	92	92	92
Heavy Vehicles, %	2	2	2	2	2	2	2	2	2	2	2	2
Mvmt Flow	59	0	16	0	0	0	5	236	0	0	93	27

Major/Minor	Minor2		Minor1			Major1		Major2				
Conflicting Flow All	354	354	107	340	367	236	121	0	0	236	0	0
Stage 1	107	107	-	247	247	-	-	-	-	-	-	-
Stage 2	247	247	-	93	121	-	-	-	-	-	-	-
Critical Hdwy	7.12	6.52	6.22	7.12	6.52	6.22	4.12	-	-	4.12	-	-
Critical Hdwy Stg 1	6.12	5.52	-	6.12	5.52	-	-	-	-	-	-	-
Critical Hdwy Stg 2	6.12	5.52	-	6.12	5.52	-	-	-	-	-	-	-
Follow-up Hdwy	3.518	4.018	3.318	3.518	4.018	3.318	2.218	-	-	2.218	-	-
Pot Cap-1 Maneuver	601	571	947	614	561	803	1467	-	-	1331	-	-
Stage 1	898	807	-	757	702	-	-	-	-	-	-	-
Stage 2	757	702	-	913	796	-	-	-	-	-	-	-
Platoon blocked, %								-	-	-	-	-
Mov Cap-1 Maneuver	599	569	947	601	559	803	1467	-	-	1331	-	-
Mov Cap-2 Maneuver	599	569	-	601	559	-	-	-	-	-	-	-
Stage 1	898	807	-	754	699	-	-	-	-	-	-	-
Stage 2	754	699	-	898	796	-	-	-	-	-	-	-

Approach	EB	WB	NB	SB
HCM Ctrl Dly, s/v	11.06	0	0.17	0
HCM LOS	B	A		

Minor Lane/Major Mvmt	NBL	NBT	NBR	EBLn1	EBLn2	WBLn1	SBL	SBT	SBR
Capacity (veh/h)	41	-	-	599	947	-	1331	-	-
HCM Lane V/C Ratio	0.004	-	-	0.098	0.017	-	-	-	-
HCM Ctrl Dly (s/v)	7.5	0	-	11.7	8.9	0	0	-	-
HCM Lane LOS	A	A	-	B	A	A	A	-	-
HCM 95th %tile Q(veh)	0	-	-	0.3	0.1	-	0	-	-

Intersection						
Int Delay, s/veh	3.8					
Movement	SEL	SER	NEL	NET	SWT	SWR
Lane Configurations						
Traffic Vol, veh/h	3	42	59	62	62	3
Future Vol, veh/h	3	42	59	62	62	3
Conflicting Peds, #/hr	0	0	0	0	0	0
Sign Control	Stop	Stop	Free	Free	Free	Free
RT Channelized	-	None	-	None	-	None
Storage Length	0	-	0	-	-	-
Veh in Median Storage, #	0	-	-	0	0	-
Grade, %	0	-	-	0	0	-
Peak Hour Factor	75	75	70	70	81	81
Heavy Vehicles, %	0	2	2	0	2	0
Mvmt Flow	4	56	84	89	77	4

Major/Minor	Minor2	Major1		Major2	
Conflicting Flow All	336	78	80	0	0
Stage 1	78	-	-	-	-
Stage 2	257	-	-	-	-
Critical Hdwy	6.4	6.22	4.12	-	-
Critical Hdwy Stg 1	5.4	-	-	-	-
Critical Hdwy Stg 2	5.4	-	-	-	-
Follow-up Hdwy	3.5	3.318	2.218	-	-
Pot Cap-1 Maneuver	664	982	1518	-	-
Stage 1	950	-	-	-	-
Stage 2	790	-	-	-	-
Platoon blocked, %				-	-
Mov Cap-1 Maneuver	627	982	1518	-	-
Mov Cap-2 Maneuver	627	-	-	-	-
Stage 1	897	-	-	-	-
Stage 2	790	-	-	-	-

Approach	SE	NE	SW
HCM Ctrl Dly, s/v	9.06	3.66	0
HCM LOS	A		

Minor Lane/Major Mvmt	NEL	NET SELn1	SWT	SWR
Capacity (veh/h)	1518	-	946	-
HCM Lane V/C Ratio	0.056	-	0.063	-
HCM Ctrl Dly (s/v)	7.5	-	9.1	-
HCM Lane LOS	A	-	A	-
HCM 95th %tile Q(veh)	0.2	-	0.2	-

HCM Unsignalized Intersection Capacity Analysis

110: Mountain View Blvd & 2260 South

02/05/2026



Movement	EBL	EBT	EBR	WBL	WBT	WBR	NBL	NBT	NBR	SBL	SBT	SBR
Lane Configurations		↕			↕			↕			↕	
Sign Control		Yield			Yield			Yield			Yield	
Traffic Volume (vph)	6	6	0	6	12	13	0	6	5	7	4	1
Future Volume (vph)	6	6	0	6	12	13	0	6	5	7	4	1
Peak Hour Factor	0.60	0.60	0.60	0.86	0.86	0.86	0.69	0.69	0.69	0.75	0.75	0.75
Hourly flow rate (vph)	10	10	0	7	14	15	0	9	7	9	5	1

Direction, Lane #	EB 1	WB 1	NB 1	SB 1
Volume Total (vph)	20	36	16	15
Volume Left (vph)	10	7	0	9
Volume Right (vph)	0	15	7	1
Hadj (s)	0.13	-0.18	-0.23	0.11
Departure Headway (s)	4.1	3.8	3.8	4.1
Degree Utilization, x	0.02	0.04	0.02	0.02
Capacity (veh/h)	857	932	920	852
Control Delay (s/veh)	7.2	7.0	6.9	7.2
Approach Delay (s/veh)	7.2	7.0	6.9	7.2
Approach LOS	A	A	A	A

Intersection Summary			
Delay		7.0	
Level of Service		A	
Intersection Capacity Utilization	16.6%	ICU Level of Service	A
Analysis Period (min)	15		

2050 No Build Condition - AM

Intersection						
Int Delay, s/veh	2.6					
Movement	WBL	WBR	NBT	NBR	SBL	SBT
Lane Configurations	Y		B			A
Traffic Vol, veh/h	12	27	105	198	69	233
Future Vol, veh/h	12	27	105	198	69	233
Conflicting Peds, #/hr	0	0	0	0	0	0
Sign Control	Stop	Stop	Free	Free	Free	Free
RT Channelized	-	None	-	None	-	None
Storage Length	0	-	-	-	-	-
Veh in Median Storage, #	0	-	0	-	-	0
Grade, %	0	-	0	-	-	0
Peak Hour Factor	34	34	68	68	54	54
Heavy Vehicles, %	0	0	0	2	0	4
Mvmt Flow	35	79	154	291	128	431

Major/Minor	Minor1	Major1	Major2		
Conflicting Flow All	987	300	0	0	446
Stage 1	300	-	-	-	-
Stage 2	687	-	-	-	-
Critical Hdwy	6.4	6.2	-	-	4.1
Critical Hdwy Stg 1	5.4	-	-	-	-
Critical Hdwy Stg 2	5.4	-	-	-	-
Follow-up Hdwy	3.5	3.3	-	-	2.2
Pot Cap-1 Maneuver	277	744	-	-	1125
Stage 1	756	-	-	-	-
Stage 2	503	-	-	-	-
Platoon blocked, %			-	-	-
Mov Cap-1 Maneuver	235	744	-	-	1125
Mov Cap-2 Maneuver	235	-	-	-	-
Stage 1	756	-	-	-	-
Stage 2	428	-	-	-	-

Approach	WB	NB	SB
HCM Ctrl Dly, s/v	15.81	0	1.97
HCM LOS	C		

Minor Lane/Major Mvmt	NBT	NBRWBLn1	SBL	SBT
Capacity (veh/h)	-	-	447	411
HCM Lane V/C Ratio	-	-	0.257	0.114
HCM Ctrl Dly (s/v)	-	-	15.8	8.6
HCM Lane LOS	-	-	C	A
HCM 95th %tile Q(veh)	-	-	1	0.4

Intersection				
Intersection Delay, s/veh	3.3			
Intersection LOS	A			
Approach	EB	WB	NB	SB
Entry Lanes	1	1	1	1
Conflicting Circle Lanes	1	1	1	1
Adj Approach Flow, veh/h	45	54	92	37
Demand Flow Rate, veh/h	48	57	94	40
Vehicles Circulating, veh/h	67	14	70	50
Vehicles Exiting, veh/h	23	150	45	21
Ped Vol Crossing Leg, #/h	0	0	0	0
Ped Cap Adj	1.000	1.000	1.000	1.000
Approach Delay, s/veh	3.3	3.1	3.5	3.2
Approach LOS	A	A	A	A
Lane	Left	Left	Left	Left
Designated Moves	LTR	LTR	LTR	LTR
Assumed Moves	LTR	LTR	LTR	LTR
RT Channelized				
Lane Util	1.000	1.000	1.000	1.000
Follow-Up Headway, s	2.609	2.609	2.609	2.609
Critical Headway, s	4.976	4.976	4.976	4.976
A (Intercept)	1380	1380	1380	1380
B (Slope)	1.02e-3	1.02e-3	1.02e-3	1.02e-3
Entry Flow, veh/h	48	57	94	40
Cap Entry Lane, veh/h	1289	1360	1285	1311
Entry HV Adj Factor	0.928	0.947	0.979	0.925
Flow Entry, veh/h	45	54	92	37
Cap Entry, veh/h	1196	1289	1257	1213
V/C Ratio	0.037	0.042	0.073	0.031
Control Delay, s/veh	3.3	3.1	3.5	3.2
LOS	A	A	A	A
95th %tile Queue, veh	0	0	0	0

Intersection						
Int Delay, s/veh	3.1					
Movement	EBT	EBR	WBL	WBT	NBL	NBR
Lane Configurations						
Traffic Vol, veh/h	116	21	10	176	68	27
Future Vol, veh/h	116	21	10	176	68	27
Conflicting Peds, #/hr	0	0	0	0	0	0
Sign Control	Free	Free	Free	Free	Stop	Stop
RT Channelized	-	None	-	None	-	None
Storage Length	-	-	-	-	0	-
Veh in Median Storage, #	0	-	-	0	0	-
Grade, %	0	-	-	0	0	-
Peak Hour Factor	82	82	75	75	70	70
Heavy Vehicles, %	9	5	11	4	2	4
Mvmt Flow	141	26	13	235	97	39

Major/Minor	Major1	Major2	Minor1		
Conflicting Flow All	0	0	167	0	416 154
Stage 1	-	-	-	-	154 -
Stage 2	-	-	-	-	261 -
Critical Hdwy	-	-	4.21	-	6.42 6.24
Critical Hdwy Stg 1	-	-	-	-	5.42 -
Critical Hdwy Stg 2	-	-	-	-	5.42 -
Follow-up Hdwy	-	-	2.299	-	3.518 3.336
Pot Cap-1 Maneuver	-	-	1358	-	593 886
Stage 1	-	-	-	-	874 -
Stage 2	-	-	-	-	782 -
Platoon blocked, %	-	-	-	-	-
Mov Cap-1 Maneuver	-	-	1358	-	587 886
Mov Cap-2 Maneuver	-	-	-	-	587 -
Stage 1	-	-	-	-	874 -
Stage 2	-	-	-	-	774 -

Approach	EB	WB	NB
HCM Ctrl Dly, s/v	0	0.41	12.01
HCM LOS			B

Minor Lane/Major Mvmt	NBLn1	EBT	EBR	WBL	WBT
Capacity (veh/h)	649	-	-	97	-
HCM Lane V/C Ratio	0.209	-	-	0.01	-
HCM Ctrl Dly (s/v)	12	-	-	7.7	0
HCM Lane LOS	B	-	-	A	A
HCM 95th %tile Q(veh)	0.8	-	-	0	-

Intersection												
Int Delay, s/veh	3											
Movement	EBL	EBT	EBR	WBL	WBT	WBR	NBL	NBT	NBR	SBL	SBT	SBR
Lane Configurations		↕			↕			↕			↕	
Traffic Vol, veh/h	4	185	3	2	258	22	6	0	3	45	0	47
Future Vol, veh/h	4	185	3	2	258	22	6	0	3	45	0	47
Conflicting Peds, #/hr	0	0	0	0	0	0	0	0	0	0	0	0
Sign Control	Free	Free	Free	Free	Free	Free	Stop	Stop	Stop	Stop	Stop	Stop
RT Channelized	-	-	None	-	-	None	-	-	None	-	-	None
Storage Length	-	-	-	-	-	-	-	-	-	-	-	-
Veh in Median Storage, #	-	0	-	-	0	-	-	0	-	-	0	-
Grade, %	-	0	-	-	0	-	-	0	-	-	0	-
Peak Hour Factor	88	88	88	79	79	79	67	67	67	67	67	67
Heavy Vehicles, %	0	6	0	0	3	25	0	0	0	14	0	10
Mvmt Flow	5	210	3	3	327	28	9	0	4	67	0	70

Major/Minor	Major1			Major2			Minor1			Minor2		
Conflicting Flow All	354	0	0	214	0	0	553	581	212	565	568	341
Stage 1	-	-	-	-	-	-	221	221	-	346	346	-
Stage 2	-	-	-	-	-	-	332	359	-	219	223	-
Critical Hdwy	4.1	-	-	4.1	-	-	7.1	6.5	6.2	7.24	6.5	6.3
Critical Hdwy Stg 1	-	-	-	-	-	-	6.1	5.5	-	6.24	5.5	-
Critical Hdwy Stg 2	-	-	-	-	-	-	6.1	5.5	-	6.24	5.5	-
Follow-up Hdwy	2.2	-	-	2.2	-	-	3.5	4	3.3	3.626	4	3.39
Pot Cap-1 Maneuver	1216	-	-	1369	-	-	447	428	833	418	435	684
Stage 1	-	-	-	-	-	-	786	724	-	646	639	-
Stage 2	-	-	-	-	-	-	686	630	-	757	723	-
Platoon blocked, %		-	-		-	-						
Mov Cap-1 Maneuver	1216	-	-	1369	-	-	399	425	833	413	432	684
Mov Cap-2 Maneuver	-	-	-	-	-	-	399	425	-	413	432	-
Stage 1	-	-	-	-	-	-	783	721	-	644	638	-
Stage 2	-	-	-	-	-	-	614	629	-	749	720	-

Approach	EB			WB			NB			SB		
HCM Ctrl Dly, s/v	0.17			0.05			12.68			14.44		
HCM LOS							B			B		

Minor Lane/Major Mvmt	NBLn1	EBL	EBT	EBR	WBL	WBT	WBR	SBLn1
Capacity (veh/h)	482	37	-	-	13	-	-	518
HCM Lane V/C Ratio	0.028	0.004	-	-	0.002	-	-	0.265
HCM Ctrl Dly (s/v)	12.7	8	0	-	7.6	0	-	14.4
HCM Lane LOS	B	A	A	-	A	A	-	B
HCM 95th %tile Q(veh)	0.1	0	-	-	0	-	-	1.1

Intersection	
Intersection Delay, s/veh	427
Intersection LOS	F

Movement	EBL	EBT	EBR	WBL	WBT	WBR	NBL	NBT	NBR	SBL	SBT	SBR
Lane Configurations		↕			↕			↕			↕	
Traffic Vol, veh/h	37	200	53	185	175	31	48	344	315	19	175	19
Future Vol, veh/h	37	200	53	185	175	31	48	344	315	19	175	19
Peak Hour Factor	0.94	0.94	0.94	0.76	0.76	0.76	0.66	0.66	0.66	0.57	0.57	0.57
Heavy Vehicles, %	13	2	9	3	3	5	11	2	3	0	0	18
Mvmt Flow	39	213	56	243	230	41	73	521	477	33	307	33
Number of Lanes	0	1	0	0	1	0	0	1	0	0	1	0

Approach	EB	WB	NB	SB
Opposing Approach	WB	EB	SB	NB
Opposing Lanes	1	1	1	1
Conflicting Approach Left	SB	NB	EB	WB
Conflicting Lanes Left	1	1	1	1
Conflicting Approach Right	NB	SB	WB	EB
Conflicting Lanes Right	1	1	1	1
HCM Control Delay, s/veh	63.4	190.6	765	83.6
HCM LOS	F	F	F	F

Lane	NBLn1	EBLn1	WBLn1	SBLn1
Vol Left, %	7%	13%	47%	9%
Vol Thru, %	49%	69%	45%	82%
Vol Right, %	45%	18%	8%	9%
Sign Control	Stop	Stop	Stop	Stop
Traffic Vol by Lane	707	290	391	213
LT Vol	48	37	185	19
Through Vol	344	200	175	175
RT Vol	315	53	31	19
Lane Flow Rate	1071	309	514	374
Geometry Grp	1	1	1	1
Degree of Util (X)	2.637	0.818	1.29	0.94
Departure Headway (Hd)	9.829	15.49	13.2	14.547
Convergence, Y/N	Yes	Yes	Yes	Yes
Cap	386	238	283	254
Service Time	7.829	13.49	11.2	12.547
HCM Lane V/C Ratio	2.775	1.298	1.816	1.472
HCM Control Delay, s/veh	765	63.4	190.6	83.6
HCM Lane LOS	F	F	F	F
HCM 95th-tile Q	79.5	6.2	17.4	8.5

HCM 7th Signalized Intersection Summary

60: 800 West & 1500 South

02/05/2026



Movement	EBL	EBT	EBR	WBL	WBT	WBR	NBL	NBT	NBR	SBL	SBT	SBR
Lane Configurations	↖	↗		↖	↗		↖	↗		↖	↗	
Traffic Volume (veh/h)	83	278	66	53	291	74	33	107	60	50	62	58
Future Volume (veh/h)	83	278	66	53	291	74	33	107	60	50	62	58
Initial Q (Qb), veh	0	0	0	0	0	0	0	0	0	0	0	0
Lane Width Adj.	1.00	1.00	1.00	1.00	1.00	1.00	1.00	1.00	1.00	1.00	1.00	1.00
Ped-Bike Adj(A_pbT)	1.00		1.00	1.00		1.00	1.00		1.00	1.00		1.00
Parking Bus, Adj	1.00	1.00	1.00	1.00	1.00	1.00	1.00	1.00	1.00	1.00	1.00	1.00
Work Zone On Approach		No		No		No		No		No		No
Adj Sat Flow, veh/h/ln	1870	1885	1841	1856	1856	1870	1900	1870	1900	1900	1841	1900
Adj Flow Rate, veh/h	111	371	88	69	378	96	46	151	85	77	95	89
Peak Hour Factor	0.75	0.75	0.75	0.77	0.77	0.77	0.71	0.71	0.71	0.65	0.65	0.65
Percent Heavy Veh, %	2	1	4	3	3	2	0	2	0	0	4	0
Cap, veh/h	451	656	156	464	636	161	450	307	173	412	239	224
Arrive On Green	0.45	0.45	0.45	0.45	0.45	0.45	0.27	0.27	0.27	0.27	0.27	0.27
Sat Flow, veh/h	920	1473	349	925	1428	363	1219	1124	633	1162	874	819
Grp Volume(v), veh/h	111	0	459	69	0	474	46	0	236	77	0	184
Grp Sat Flow(s),veh/h/ln	920	0	1822	925	0	1790	1219	0	1756	1162	0	1693
Q Serve(g_s), s	3.3	0.0	6.0	1.9	0.0	6.4	1.0	0.0	3.6	1.9	0.0	2.8
Cycle Q Clear(g_c), s	9.7	0.0	6.0	7.9	0.0	6.4	3.9	0.0	3.6	5.5	0.0	2.8
Prop In Lane	1.00		0.19	1.00		0.20	1.00		0.36	1.00		0.48
Lane Grp Cap(c), veh/h	451	0	811	464	0	797	450	0	480	412	0	462
V/C Ratio(X)	0.25	0.00	0.57	0.15	0.00	0.59	0.10	0.00	0.49	0.19	0.00	0.40
Avail Cap(c_a), veh/h	661	0	1226	675	0	1205	1052	0	1347	986	0	1299
HCM Platoon Ratio	1.00	1.00	1.00	1.00	1.00	1.00	1.00	1.00	1.00	1.00	1.00	1.00
Upstream Filter(I)	1.00	0.00	1.00	1.00	0.00	1.00	1.00	0.00	1.00	1.00	0.00	1.00
Uniform Delay (d), s/veh	10.3	0.0	6.6	9.5	0.0	6.7	11.0	0.0	9.8	12.1	0.0	9.5
Incr Delay (d2), s/veh	0.3	0.0	0.6	0.1	0.0	0.7	0.1	0.0	0.8	0.2	0.0	0.6
Initial Q Delay(d3), s/veh	0.0	0.0	0.0	0.0	0.0	0.0	0.0	0.0	0.0	0.0	0.0	0.0
%ile BackOfQ(95%),veh/ln	0.9	0.0	2.5	0.5	0.0	2.7	0.4	0.0	1.9	0.7	0.0	1.5
Unsig. Movement Delay, s/veh												
LnGrp Delay(d), s/veh	10.6	0.0	7.2	9.6	0.0	7.4	11.1	0.0	10.5	12.3	0.0	10.0
LnGrp LOS	B		A	A		A	B		B	B		B
Approach Vol, veh/h		570			543			282			261	
Approach Delay, s/veh		7.9			7.7			10.6			10.7	
Approach LOS		A			A			B			B	
Timer - Assigned Phs		2		4		6		8				
Phs Duration (G+Y+Rc), s		13.2		18.7		13.2		18.7				
Change Period (Y+Rc), s		4.5		4.5		4.5		4.5				
Max Green Setting (Gmax), s		24.5		21.5		24.5		21.5				
Max Q Clear Time (g_c+I1), s		5.9		11.7		7.5		9.9				
Green Ext Time (p_c), s		1.4		2.5		1.2		2.7				
Intersection Summary												
HCM 7th Control Delay, s/veh			8.7									
HCM 7th LOS			A									

Intersection												
Int Delay, s/veh	3.5											
Movement	EBL	EBT	EBR	WBL	WBT	WBR	NBL	NBT	NBR	SBL	SBT	SBR
Lane Configurations		↕			↕			↕			↕	
Traffic Vol, veh/h	1	16	2	49	6	9	0	25	75	20	31	5
Future Vol, veh/h	1	16	2	49	6	9	0	25	75	20	31	5
Conflicting Peds, #/hr	0	0	0	0	0	0	0	0	0	0	0	0
Sign Control	Stop	Stop	Stop	Stop	Stop	Stop	Free	Free	Free	Free	Free	Free
RT Channelized	-	-	None	-	-	None	-	-	None	-	-	None
Storage Length	-	-	-	-	-	-	-	-	-	-	-	-
Veh in Median Storage, #	-	0	-	-	0	-	-	0	-	-	0	-
Grade, %	-	0	-	-	0	-	-	0	-	-	0	-
Peak Hour Factor	71	71	71	78	78	78	45	45	45	68	68	68
Heavy Vehicles, %	0	7	100	0	0	13	0	5	2	6	4	25
Mvmt Flow	1	23	3	63	8	12	0	56	167	29	46	7

Major/Minor	Minor2		Minor1		Major1			Major2				
Conflicting Flow All	167	330	49	255	251	139	53	0	0	222	0	0
Stage 1	108	108	-	139	139	-	-	-	-	-	-	-
Stage 2	59	222	-	116	112	-	-	-	-	-	-	-
Critical Hdwy	7.1	6.57	7.2	7.1	6.5	6.33	4.1	-	-	4.16	-	-
Critical Hdwy Stg 1	6.1	5.57	-	6.1	5.5	-	-	-	-	-	-	-
Critical Hdwy Stg 2	6.1	5.57	-	6.1	5.5	-	-	-	-	-	-	-
Follow-up Hdwy	3.5	4.063	4.2	3.5	4	3.417	2.2	-	-	2.254	-	-
Pot Cap-1 Maneuver	801	581	799	703	656	881	1566	-	-	1323	-	-
Stage 1	902	796	-	869	786	-	-	-	-	-	-	-
Stage 2	957	710	-	894	807	-	-	-	-	-	-	-
Platoon blocked, %								-	-	-	-	-
Mov Cap-1 Maneuver	763	568	799	658	641	881	1566	-	-	1323	-	-
Mov Cap-2 Maneuver	763	568	-	658	641	-	-	-	-	-	-	-
Stage 1	882	778	-	869	786	-	-	-	-	-	-	-
Stage 2	935	710	-	845	788	-	-	-	-	-	-	-

Approach	EB		WB		NB		SB	
HCM Ctrl Dly, s/v	11.35		11.02		0		2.78	
HCM LOS	B		B					

Minor Lane/Major Mvmt	NBL	NBT	NBR	EBLn1	WBLn1	SBL	SBT	SBR
Capacity (veh/h)	1566	-	-	594	680	625	-	-
HCM Lane V/C Ratio	-	-	-	0.045	0.121	0.022	-	-
HCM Ctrl Dly (s/v)	0	-	-	11.3	11	7.8	0	-
HCM Lane LOS	A	-	-	B	B	A	A	-
HCM 95th %tile Q(veh)	0	-	-	0.1	0.4	0.1	-	-

Intersection	
Intersection Delay, s/veh	7.5
Intersection LOS	A

Movement	EBL	EBT	EBR	WBL	WBT	WBR	NBL	NBT	NBR	SBL	SBT	SBR
Lane Configurations		↕			↕			↕			↕	
Traffic Vol, veh/h	0	18	3	28	16	5	15	0	57	7	1	0
Future Vol, veh/h	0	18	3	28	16	5	15	0	57	7	1	0
Peak Hour Factor	0.79	0.79	0.79	0.60	0.60	0.60	0.68	0.68	0.68	0.88	0.88	0.88
Heavy Vehicles, %	0	6	33	8	0	0	8	0	0	0	0	0
Mvmt Flow	0	23	4	47	27	8	22	0	84	8	1	0
Number of Lanes	0	1	0	0	1	0	0	1	0	0	1	0

Approach	EB	WB	NB	SB
Opposing Approach	WB	EB	SB	NB
Opposing Lanes	1	1	1	1
Conflicting Approach Left	SB	NB	EB	WB
Conflicting Lanes Left	1	1	1	1
Conflicting Approach Right	NB	SB	WB	EB
Conflicting Lanes Right	1	1	1	1
HCM Control Delay, s/veh	7.4	7.8	7.3	7.5
HCM LOS	A	A	A	A

Lane	NBLn1	EBLn1	WBLn1	SBLn1
Vol Left, %	21%	0%	57%	88%
Vol Thru, %	0%	86%	33%	13%
Vol Right, %	79%	14%	10%	0%
Sign Control	Stop	Stop	Stop	Stop
Traffic Vol by Lane	72	21	49	8
LT Vol	15	0	28	7
Through Vol	0	18	16	1
RT Vol	57	3	5	0
Lane Flow Rate	106	27	82	9
Geometry Grp	1	1	1	1
Degree of Util (X)	0.112	0.031	0.098	0.011
Departure Headway (Hd)	3.798	4.18	4.31	4.347
Convergence, Y/N	Yes	Yes	Yes	Yes
Cap	934	849	827	814
Service Time	1.863	2.244	2.357	2.426
HCM Lane V/C Ratio	0.113	0.032	0.099	0.011
HCM Control Delay, s/veh	7.3	7.4	7.8	7.5
HCM Lane LOS	A	A	A	A
HCM 95th-tile Q	0.4	0.1	0.3	0

Intersection												
Int Delay, s/veh	13.5											
Movement	EBL	EBT	EBR	WBL	WBT	WBR	NBL	NBT	NBR	SBL	SBT	SBR
Lane Configurations												
Traffic Vol, veh/h	197	0	126	0	0	0	96	101	4	2	285	370
Future Vol, veh/h	197	0	126	0	0	0	96	101	4	2	285	370
Conflicting Peds, #/hr	0	0	0	0	0	0	0	0	0	0	0	0
Sign Control	Stop	Stop	Stop	Stop	Stop	Stop	Free	Free	Free	Free	Free	Free
RT Channelized	-	-	None	-	-	None	-	-	None	-	-	None
Storage Length	100	-	-	-	-	-	-	-	-	-	-	-
Veh in Median Storage, #	-	0	-	-	0	-	-	0	-	-	0	-
Grade, %	-	0	-	-	0	-	-	0	-	-	0	-
Peak Hour Factor	92	92	92	92	92	92	92	92	92	92	92	92
Heavy Vehicles, %	2	2	2	2	2	2	2	2	2	2	2	2
Mvmt Flow	214	0	137	0	0	0	104	110	4	2	310	402

Major/Minor	Minor2		Minor1			Major1		Major2				
Conflicting Flow All	834	838	511	635	1037	112	712	0	0	114	0	0
Stage 1	515	515	-	321	321	-	-	-	-	-	-	-
Stage 2	318	323	-	314	716	-	-	-	-	-	-	-
Critical Hdwy	7.12	6.52	6.22	7.12	6.52	6.22	4.12	-	-	4.12	-	-
Critical Hdwy Stg 1	6.12	5.52	-	6.12	5.52	-	-	-	-	-	-	-
Critical Hdwy Stg 2	6.12	5.52	-	6.12	5.52	-	-	-	-	-	-	-
Follow-up Hdwy	3.518	4.018	3.318	3.518	4.018	3.318	2.218	-	-	2.218	-	-
Pot Cap-1 Maneuver	288	302	563	391	231	941	888	-	-	1475	-	-
Stage 1	542	535	-	691	652	-	-	-	-	-	-	-
Stage 2	693	650	-	697	434	-	-	-	-	-	-	-
Platoon blocked, %								-	-	-	-	-
Mov Cap-1 Maneuver	251	264	563	258	202	941	888	-	-	1475	-	-
Mov Cap-2 Maneuver	251	264	-	258	202	-	-	-	-	-	-	-
Stage 1	541	533	-	604	570	-	-	-	-	-	-	-
Stage 2	606	569	-	526	433	-	-	-	-	-	-	-

Approach	EB		WB		NB		SB	
HCM Ctrl Dly, s/v	46.49		0		4.58		0.02	
HCM LOS	E		A					

Minor Lane/Major Mvmt	NBL	NBT	NBR	EBLn1	EBLn2	WBLn1	SBL	SBT	SBR
Capacity (veh/h)	831	-	-	251	563	-	5	-	-
HCM Lane V/C Ratio	0.118	-	-	0.854	0.243	-	0.001	-	-
HCM Ctrl Dly (s/v)	9.6	0	-	67.6	13.4	0	7.4	0	-
HCM Lane LOS	A	A	-	F	B	A	A	A	-
HCM 95th %tile Q(veh)	0.4	-	-	7	0.9	-	0	-	-

Intersection						
Int Delay, s/veh	5					
Movement	SEL	SER	NEL	NET	SWT	SWR
Lane Configurations						
Traffic Vol, veh/h	5	75	60	59	41	5
Future Vol, veh/h	5	75	60	59	41	5
Conflicting Peds, #/hr	0	0	0	0	0	0
Sign Control	Stop	Stop	Free	Free	Free	Free
RT Channelized	-	None	-	None	-	None
Storage Length	0	-	0	-	-	-
Veh in Median Storage, #	0	-	-	0	0	-
Grade, %	0	-	-	0	0	-
Peak Hour Factor	63	63	75	75	67	67
Heavy Vehicles, %	25	2	0	0	0	25
Mvmt Flow	8	119	80	79	61	7

Major/Minor	Minor2	Major1		Major2	
Conflicting Flow All	304	65	69	0	0
Stage 1	65	-	-	-	-
Stage 2	239	-	-	-	-
Critical Hdwy	6.65	6.22	4.1	-	-
Critical Hdwy Stg 1	5.65	-	-	-	-
Critical Hdwy Stg 2	5.65	-	-	-	-
Follow-up Hdwy	3.725	3.318	2.2	-	-
Pot Cap-1 Maneuver	643	999	1545	-	-
Stage 1	902	-	-	-	-
Stage 2	750	-	-	-	-
Platoon blocked, %				-	-
Mov Cap-1 Maneuver	609	999	1545	-	-
Mov Cap-2 Maneuver	609	-	-	-	-
Stage 1	856	-	-	-	-
Stage 2	750	-	-	-	-

Approach	SE	NE	SW
HCM Ctrl Dly, s/v	9.32	3.76	0
HCM LOS	A		

Minor Lane/Major Mvmt	NEL	NET SELn1	SWT	SWR
Capacity (veh/h)	1545	-	961	-
HCM Lane V/C Ratio	0.052	-	0.132	-
HCM Ctrl Dly (s/v)	7.5	-	9.3	-
HCM Lane LOS	A	-	A	-
HCM 95th %tile Q(veh)	0.2	-	0.5	-

HCM Unsignalized Intersection Capacity Analysis
 110: Mountain View Blvd & 2260 South

02/05/2026

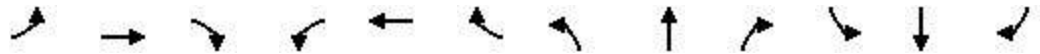

Movement	EBL	EBT	EBR	WBL	WBT	WBR	NBL	NBT	NBR	SBL	SBT	SBR
Lane Configurations		↕			↕			↕			↕	
Sign Control		Yield			Yield			Yield			Yield	
Traffic Volume (vph)	6	7	0	2	1	8	0	6	6	8	3	3
Future Volume (vph)	6	7	0	2	1	8	0	6	6	8	3	3
Peak Hour Factor	0.55	0.55	0.55	0.42	0.42	0.42	0.50	0.50	0.50	0.33	0.33	0.33
Hourly flow rate (vph)	11	13	0	5	2	19	0	12	12	24	9	9

Direction, Lane #	EB 1	WB 1	NB 1	SB 1
Volume Total (vph)	24	26	24	42
Volume Left (vph)	11	5	0	24
Volume Right (vph)	0	19	12	9
Hadj (s)	0.55	-0.06	-0.13	0.23
Departure Headway (s)	4.6	4.0	3.9	4.3
Degree Utilization, x	0.03	0.03	0.03	0.05
Capacity (veh/h)	762	878	891	829
Control Delay (s/veh)	7.8	7.1	7.0	7.5
Approach Delay (s/veh)	7.8	7.1	7.0	7.5
Approach LOS	A	A	A	A

Intersection Summary

Delay	7.4
Level of Service	A
Intersection Capacity Utilization	17.5%
ICU Level of Service	A
Analysis Period (min)	15

2050 No Build Condition - PM

Intersection						
Int Delay, s/veh	1					
Movement	WBL	WBR	NBT	NBR	SBL	SBT
Lane Configurations	W		T			T
Traffic Vol, veh/h	11	16	179	12	18	250
Future Vol, veh/h	11	16	179	12	18	250
Conflicting Peds, #/hr	0	0	0	0	0	0
Sign Control	Stop	Stop	Free	Free	Free	Free
RT Channelized	-	None	-	None	-	None
Storage Length	0	-	-	-	-	-
Veh in Median Storage, #	0	-	0	-	-	0
Grade, %	0	-	0	-	-	0
Peak Hour Factor	75	75	81	81	91	91
Heavy Vehicles, %	10	7	2	0	8	0
Mvmt Flow	15	21	221	15	20	275

Major/Minor	Minor1	Major1	Major2		
Conflicting Flow All	543	228	0	0	236
Stage 1	228	-	-	-	-
Stage 2	314	-	-	-	-
Critical Hdwy	6.5	6.27	-	-	4.18
Critical Hdwy Stg 1	5.5	-	-	-	-
Critical Hdwy Stg 2	5.5	-	-	-	-
Follow-up Hdwy	3.59	3.363	-	-	2.272
Pot Cap-1 Maneuver	487	799	-	-	1297
Stage 1	791	-	-	-	-
Stage 2	723	-	-	-	-
Platoon blocked, %			-	-	-
Mov Cap-1 Maneuver	479	799	-	-	1297
Mov Cap-2 Maneuver	479	-	-	-	-
Stage 1	791	-	-	-	-
Stage 2	710	-	-	-	-

Approach	WB	NB	SB
HCM Ctrl Dly, s/v	11.08	0	0.53
HCM LOS	B		

Minor Lane/Major Mvmt	NBT	NBRWBLn1	SBL	SBT
Capacity (veh/h)	-	-	628	121
HCM Lane V/C Ratio	-	-	0.057	0.015
HCM Ctrl Dly (s/v)	-	-	11.1	7.8
HCM Lane LOS	-	-	B	A
HCM 95th %tile Q(veh)	-	-	0.2	0

Intersection				
Intersection Delay, s/veh	3.9			
Intersection LOS	A			
Approach	EB	WB	NB	SB
Entry Lanes	1	1	1	1
Conflicting Circle Lanes	1	1	1	1
Adj Approach Flow, veh/h	39	259	62	70
Demand Flow Rate, veh/h	41	263	64	73
Vehicles Circulating, veh/h	135	3	103	117
Vehicles Exiting, veh/h	55	164	73	149
Ped Vol Crossing Leg, #/h	0	0	0	0
Ped Cap Adj	1.000	1.000	1.000	1.000
Approach Delay, s/veh	3.4	4.2	3.4	3.6
Approach LOS	A	A	A	A
Lane	Left	Left	Left	Left
Designated Moves	LTR	LTR	LTR	LTR
Assumed Moves	LTR	LTR	LTR	LTR
RT Channelized				
Lane Util	1.000	1.000	1.000	1.000
Follow-Up Headway, s	2.609	2.609	2.609	2.609
Critical Headway, s	4.976	4.976	4.976	4.976
A (Intercept)	1380	1380	1380	1380
B (Slope)	1.02e-3	1.02e-3	1.02e-3	1.02e-3
Entry Flow, veh/h	41	263	64	73
Cap Entry Lane, veh/h	1202	1376	1242	1225
Entry HV Adj Factor	0.959	0.985	0.969	0.959
Flow Entry, veh/h	39	259	62	70
Cap Entry, veh/h	1153	1355	1203	1174
V/C Ratio	0.034	0.191	0.052	0.060
Control Delay, s/veh	3.4	4.2	3.4	3.6
LOS	A	A	A	A
95th %tile Queue, veh	0	1	0	0

Intersection						
Int Delay, s/veh	1.6					
Movement	EBT	EBR	WBL	WBT	NBL	NBR
Lane Configurations						
Traffic Vol, veh/h	238	71	25	228	38	12
Future Vol, veh/h	238	71	25	228	38	12
Conflicting Peds, #/hr	0	0	0	0	0	0
Sign Control	Free	Free	Free	Free	Stop	Stop
RT Channelized	-	None	-	None	-	None
Storage Length	-	-	-	-	0	-
Veh in Median Storage, #	0	-	-	0	0	-
Grade, %	0	-	-	0	0	-
Peak Hour Factor	88	88	89	89	75	75
Heavy Vehicles, %	2	0	5	1	0	0
Mvmt Flow	270	81	28	256	51	16

Major/Minor	Major1	Major2	Minor1		
Conflicting Flow All	0	0	351	0	623 311
Stage 1	-	-	-	-	311 -
Stage 2	-	-	-	-	312 -
Critical Hdwy	-	-	4.15	-	6.4 6.2
Critical Hdwy Stg 1	-	-	-	-	5.4 -
Critical Hdwy Stg 2	-	-	-	-	5.4 -
Follow-up Hdwy	-	-	2.245	-	3.5 3.3
Pot Cap-1 Maneuver	-	-	1191	-	453 734
Stage 1	-	-	-	-	748 -
Stage 2	-	-	-	-	746 -
Platoon blocked, %	-	-	-	-	-
Mov Cap-1 Maneuver	-	-	1191	-	440 734
Mov Cap-2 Maneuver	-	-	-	-	440 -
Stage 1	-	-	-	-	748 -
Stage 2	-	-	-	-	726 -

Approach	EB	WB	NB
HCM Ctrl Dly, s/v	0	0.8	13.56
HCM LOS			B

Minor Lane/Major Mvmt	NBLn1	EBT	EBR	WBL	WBT
Capacity (veh/h)	487	-	-	178	-
HCM Lane V/C Ratio	0.137	-	-	0.024	-
HCM Ctrl Dly (s/v)	13.6	-	-	8.1	0
HCM Lane LOS	B	-	-	A	A
HCM 95th %tile Q(veh)	0.5	-	-	0.1	-

Intersection												
Int Delay, s/veh	1.8											
Movement	EBL	EBT	EBR	WBL	WBT	WBR	NBL	NBT	NBR	SBL	SBT	SBR
Lane Configurations		↕			↕			↕			↕	
Traffic Vol, veh/h	34	298	3	18	434	18	0	0	9	13	0	23
Future Vol, veh/h	34	298	3	18	434	18	0	0	9	13	0	23
Conflicting Peds, #/hr	0	0	0	0	0	0	0	0	0	0	0	0
Sign Control	Free	Free	Free	Free	Free	Free	Stop	Stop	Stop	Stop	Stop	Stop
RT Channelized	-	-	None	-	-	None	-	-	None	-	-	None
Storage Length	-	-	-	-	-	-	-	-	-	-	-	-
Veh in Median Storage, #	-	0	-	-	0	-	-	0	-	-	0	-
Grade, %	-	0	-	-	0	-	-	0	-	-	0	-
Peak Hour Factor	86	86	86	90	90	90	40	40	40	60	60	60
Heavy Vehicles, %	4	2	0	0	0	0	0	0	0	0	0	0
Mvmt Flow	40	347	3	20	482	20	0	0	23	22	0	38

Major/Minor	Major1			Major2			Minor1			Minor2		
Conflicting Flow All	502	0	0	350	0	0	950	970	348	958	961	492
Stage 1	-	-	-	-	-	-	427	427	-	532	532	-
Stage 2	-	-	-	-	-	-	522	542	-	426	429	-
Critical Hdwy	4.14	-	-	4.1	-	-	7.1	6.5	6.2	7.1	6.5	6.2
Critical Hdwy Stg 1	-	-	-	-	-	-	6.1	5.5	-	6.1	5.5	-
Critical Hdwy Stg 2	-	-	-	-	-	-	6.1	5.5	-	6.1	5.5	-
Follow-up Hdwy	2.236	-	-	2.2	-	-	3.5	4	3.3	3.5	4	3.3
Pot Cap-1 Maneuver	1052	-	-	1220	-	-	242	255	700	239	258	581
Stage 1	-	-	-	-	-	-	609	588	-	535	529	-
Stage 2	-	-	-	-	-	-	541	523	-	611	587	-
Platoon blocked, %	-	-	-	-	-	-	-	-	-	-	-	-
Mov Cap-1 Maneuver	1052	-	-	1220	-	-	211	238	700	216	241	581
Mov Cap-2 Maneuver	-	-	-	-	-	-	211	238	-	216	241	-
Stage 1	-	-	-	-	-	-	581	561	-	522	517	-
Stage 2	-	-	-	-	-	-	494	511	-	563	560	-

Approach	EB			WB			NB			SB		
HCM Ctrl Dly, s/v	0.87			0.31			10.32			16.98		
HCM LOS							B			C		

Minor Lane/Major Mvmt	NBLn1	EBL	EBT	EBR	WBL	WBT	WBR	SBLn1
Capacity (veh/h)	700	182	-	-	68	-	-	360
HCM Lane V/C Ratio	0.032	0.038	-	-	0.016	-	-	0.167
HCM Ctrl Dly (s/v)	10.3	8.6	0	-	8	0	-	17
HCM Lane LOS	B	A	A	-	A	A	-	C
HCM 95th %tile Q(veh)	0.1	0.1	-	-	0	-	-	0.6

Intersection	
Intersection Delay, s/veh	332.6
Intersection LOS	F

Movement	EBL	EBT	EBR	WBL	WBT	WBR	NBL	NBT	NBR	SBL	SBT	SBR
Lane Configurations		↕			↕			↕			↕	
Traffic Vol, veh/h	50	286	44	126	352	78	67	488	208	42	105	76
Future Vol, veh/h	50	286	44	126	352	78	67	488	208	42	105	76
Peak Hour Factor	0.83	0.83	0.83	0.77	0.77	0.77	0.91	0.91	0.91	0.83	0.83	0.83
Heavy Vehicles, %	7	2	0	3	0	4	0	1	5	3	3	3
Mvmt Flow	60	345	53	164	457	101	74	536	229	51	127	92
Number of Lanes	0	1	0	0	1	0	0	1	0	0	1	0

Approach	EB	WB	NB	SB
Opposing Approach	WB	EB	SB	NB
Opposing Lanes	1	1	1	1
Conflicting Approach Left	SB	NB	EB	WB
Conflicting Lanes Left	1	1	1	1
Conflicting Approach Right	NB	SB	WB	EB
Conflicting Lanes Right	1	1	1	1
HCM Control Delay, s/veh	134.6	383	487.7	50.5
HCM LOS	F	F	F	F

Lane	NBLn1	EBLn1	WBLn1	SBLn1
Vol Left, %	9%	13%	23%	19%
Vol Thru, %	64%	75%	63%	47%
Vol Right, %	27%	12%	14%	34%
Sign Control	Stop	Stop	Stop	Stop
Traffic Vol by Lane	763	380	556	223
LT Vol	67	50	126	42
Through Vol	488	286	352	105
RT Vol	208	44	78	76
Lane Flow Rate	838	458	722	269
Geometry Grp	1	1	1	1
Degree of Util (X)	2.007	1.124	1.76	0.708
Departure Headway (Hd)	10.852	14.263	12.048	16.053
Convergence, Y/N	Yes	Yes	Yes	Yes
Cap	344	261	310	228
Service Time	8.852	12.263	10.048	14.053
HCM Lane V/C Ratio	2.436	1.755	2.329	1.18
HCM Control Delay, s/veh	487.7	134.6	383	50.5
HCM Lane LOS	F	F	F	F
HCM 95th-tile Q	47.1	12.5	34.2	4.6

HCM 7th Signalized Intersection Summary

60: 800 West & 1500 South

02/05/2026



Movement	EBL	EBT	EBR	WBL	WBT	WBR	NBL	NBT	NBR	SBL	SBT	SBR
Lane Configurations	↖	↗		↖	↗		↖	↗		↖	↗	
Traffic Volume (veh/h)	64	286	54	116	355	77	49	93	97	62	86	63
Future Volume (veh/h)	64	286	54	116	355	77	49	93	97	62	86	63
Initial Q (Qb), veh	0	0	0	0	0	0	0	0	0	0	0	0
Lane Width Adj.	1.00	1.00	1.00	1.00	1.00	1.00	1.00	1.00	1.00	1.00	1.00	1.00
Ped-Bike Adj(A_pbT)	1.00		1.00	1.00		1.00	1.00		1.00	1.00		1.00
Parking Bus, Adj	1.00	1.00	1.00	1.00	1.00	1.00	1.00	1.00	1.00	1.00	1.00	1.00
Work Zone On Approach		No		No		No		No		No		No
Adj Sat Flow, veh/h/ln	1900	1885	1900	1900	1870	1870	1870	1900	1885	1900	1900	1841
Adj Flow Rate, veh/h	81	362	68	147	449	97	54	102	107	119	165	121
Peak Hour Factor	0.79	0.79	0.79	0.79	0.79	0.79	0.91	0.91	0.91	0.52	0.52	0.52
Percent Heavy Veh, %	0	1	0	0	2	2	2	0	1	0	0	4
Cap, veh/h	384	684	128	472	660	143	385	253	266	448	304	223
Arrive On Green	0.44	0.44	0.44	0.44	0.44	0.44	0.30	0.30	0.30	0.30	0.30	0.30
Sat Flow, veh/h	874	1543	290	973	1490	322	1093	849	891	1191	1019	747
Grp Volume(v), veh/h	81	0	430	147	0	546	54	0	209	119	0	286
Grp Sat Flow(s),veh/h/ln	874	0	1833	973	0	1812	1093	0	1740	1191	0	1766
Q Serve(g_s), s	2.8	0.0	5.9	4.5	0.0	8.4	1.5	0.0	3.3	3.1	0.0	4.7
Cycle Q Clear(g_c), s	11.2	0.0	5.9	10.4	0.0	8.4	6.2	0.0	3.3	6.4	0.0	4.7
Prop In Lane	1.00		0.16	1.00		0.18	1.00		0.51	1.00		0.42
Lane Grp Cap(c), veh/h	384	0	812	472	0	803	385	0	519	448	0	527
V/C Ratio(X)	0.21	0.00	0.53	0.31	0.00	0.68	0.14	0.00	0.40	0.27	0.00	0.54
Avail Cap(c_a), veh/h	537	0	1132	642	0	1120	828	0	1225	932	0	1243
HCM Platoon Ratio	1.00	1.00	1.00	1.00	1.00	1.00	1.00	1.00	1.00	1.00	1.00	1.00
Upstream Filter(l)	1.00	0.00	1.00	1.00	0.00	1.00	1.00	0.00	1.00	1.00	0.00	1.00
Uniform Delay (d), s/veh	12.2	0.0	7.1	10.9	0.0	7.7	12.8	0.0	9.7	12.3	0.0	10.2
Incr Delay (d2), s/veh	0.3	0.0	0.5	0.4	0.0	1.0	0.2	0.0	0.5	0.3	0.0	0.9
Initial Q Delay(d3), s/veh	0.0	0.0	0.0	0.0	0.0	0.0	0.0	0.0	0.0	0.0	0.0	0.0
%ile BackOfQ(95%),veh/ln	0.8	0.0	2.7	1.4	0.0	3.9	0.6	0.0	1.8	1.2	0.0	2.6
Unsig. Movement Delay, s/veh												
LnGrp Delay(d), s/veh	12.5	0.0	7.6	11.2	0.0	8.7	13.0	0.0	10.2	12.6	0.0	11.1
LnGrp LOS	B		A	B		A	B		B	B		B
Approach Vol, veh/h		511			693			263			405	
Approach Delay, s/veh		8.4			9.3			10.8			11.5	
Approach LOS		A			A			B			B	
Timer - Assigned Phs		2		4		6		8				
Phs Duration (G+Y+Rc), s		14.9		19.9		14.9		19.9				
Change Period (Y+Rc), s		4.5		4.5		4.5		4.5				
Max Green Setting (Gmax), s		24.5		21.5		24.5		21.5				
Max Q Clear Time (g_c+1), s		8.2		13.2		8.4		12.4				
Green Ext Time (p_c), s		1.3		2.0		2.0		3.0				
Intersection Summary												
HCM 7th Control Delay, s/veh			9.7									
HCM 7th LOS			A									

Intersection												
Int Delay, s/veh	6.4											
Movement	EBL	EBT	EBR	WBL	WBT	WBR	NBL	NBT	NBR	SBL	SBT	SBR
Lane Configurations		↕			↕			↕			↕	
Traffic Vol, veh/h	0	15	0	41	18	28	1	9	33	14	2	1
Future Vol, veh/h	0	15	0	41	18	28	1	9	33	14	2	1
Conflicting Peds, #/hr	0	0	0	0	0	0	0	0	0	0	0	0
Sign Control	Stop	Stop	Stop	Stop	Stop	Stop	Free	Free	Free	Free	Free	Free
RT Channelized	-	-	None	-	-	None	-	-	None	-	-	None
Storage Length	-	-	-	-	-	-	-	-	-	-	-	-
Veh in Median Storage, #	-	0	-	-	0	-	-	0	-	-	0	-
Grade, %	-	0	-	-	0	-	-	0	-	-	0	-
Peak Hour Factor	65	65	65	66	66	66	50	50	50	54	54	54
Heavy Vehicles, %	0	0	0	0	6	4	0	0	0	0	50	0
Mvmt Flow	0	23	0	62	27	42	2	18	66	26	4	2

Major/Minor	Minor2		Minor1			Major1			Major2			
Conflicting Flow All	92	144	5	122	112	51	6	0	0	84	0	0
Stage 1	56	56	-	55	55	-	-	-	-	-	-	-
Stage 2	36	88	-	67	57	-	-	-	-	-	-	-
Critical Hdwy	7.1	6.5	6.2	7.1	6.56	6.24	4.1	-	-	4.1	-	-
Critical Hdwy Stg 1	6.1	5.5	-	6.1	5.56	-	-	-	-	-	-	-
Critical Hdwy Stg 2	6.1	5.5	-	6.1	5.56	-	-	-	-	-	-	-
Follow-up Hdwy	3.5	4	3.3	3.5	4.054	3.336	2.2	-	-	2.2	-	-
Pot Cap-1 Maneuver	897	750	1085	857	770	1011	1629	-	-	1526	-	-
Stage 1	961	852	-	962	841	-	-	-	-	-	-	-
Stage 2	985	826	-	948	839	-	-	-	-	-	-	-
Platoon blocked, %								-	-	-	-	-
Mov Cap-1 Maneuver	813	737	1085	816	756	1011	1629	-	-	1526	-	-
Mov Cap-2 Maneuver	813	737	-	816	756	-	-	-	-	-	-	-
Stage 1	944	837	-	961	840	-	-	-	-	-	-	-
Stage 2	912	825	-	906	825	-	-	-	-	-	-	-

Approach	EB		WB			NB			SB		
HCM Ctrl Dly, s/v	10.04		9.98			0.17			6.09		
HCM LOS	B		A								

Minor Lane/Major Mvmt	NBL	NBT	NBR	EBLn1	WBLn1	SBL	SBT	SBR
Capacity (veh/h)	36	-	-	737	855	1390	-	-
HCM Lane V/C Ratio	0.001	-	-	0.031	0.154	0.017	-	-
HCM Ctrl Dly (s/v)	7.2	0	-	10	10	7.4	0	-
HCM Lane LOS	A	A	-	B	A	A	A	-
HCM 95th %tile Q(veh)	0	-	-	0.1	0.5	0.1	-	-

Intersection	
Intersection Delay, s/veh	7.6
Intersection LOS	A

Movement	EBL	EBT	EBR	WBL	WBT	WBR	NBL	NBT	NBR	SBL	SBT	SBR
Lane Configurations		↕			↕			↕			↕	
Traffic Vol, veh/h	2	28	14	45	34	12	11	5	55	7	3	2
Future Vol, veh/h	2	28	14	45	34	12	11	5	55	7	3	2
Peak Hour Factor	0.70	0.70	0.70	0.78	0.78	0.78	0.88	0.88	0.88	0.43	0.43	0.43
Heavy Vehicles, %	0	0	0	0	3	0	0	0	0	0	0	0
Mvmt Flow	3	40	20	58	44	15	13	6	63	16	7	5
Number of Lanes	0	1	0	0	1	0	0	1	0	0	1	0

Approach	EB	WB	NB	SB
Opposing Approach	WB	EB	SB	NB
Opposing Lanes	1	1	1	1
Conflicting Approach Left	SB	NB	EB	WB
Conflicting Lanes Left	1	1	1	1
Conflicting Approach Right	NB	SB	WB	EB
Conflicting Lanes Right	1	1	1	1
HCM Control Delay, s/veh	7.4	7.9	7.3	7.5
HCM LOS	A	A	A	A

Lane	NBLn1	EBLn1	WBLn1	SBLn1
Vol Left, %	15%	5%	49%	58%
Vol Thru, %	7%	64%	37%	25%
Vol Right, %	77%	32%	13%	17%
Sign Control	Stop	Stop	Stop	Stop
Traffic Vol by Lane	71	44	91	12
LT Vol	11	2	45	7
Through Vol	5	28	34	3
RT Vol	55	14	12	2
Lane Flow Rate	81	63	117	28
Geometry Grp	1	1	1	1
Degree of Util (X)	0.085	0.07	0.135	0.033
Departure Headway (Hd)	3.797	3.998	4.158	4.292
Convergence, Y/N	Yes	Yes	Yes	Yes
Cap	926	886	856	820
Service Time	1.891	2.067	2.211	2.391
HCM Lane V/C Ratio	0.087	0.071	0.137	0.034
HCM Control Delay, s/veh	7.3	7.4	7.9	7.5
HCM Lane LOS	A	A	A	A
HCM 95th-tile Q	0.3	0.2	0.5	0.1

Intersection												
Int Delay, s/veh	2.2											
Movement	EBL	EBT	EBR	WBL	WBT	WBR	NBL	NBT	NBR	SBL	SBT	SBR
Lane Configurations												
Traffic Vol, veh/h	74	0	21	0	0	0	9	407	0	0	149	43
Future Vol, veh/h	74	0	21	0	0	0	9	407	0	0	149	43
Conflicting Peds, #/hr	0	0	0	0	0	0	0	0	0	0	0	0
Sign Control	Stop	Stop	Stop	Stop	Stop	Stop	Free	Free	Free	Free	Free	Free
RT Channelized	-	-	None	-	-	None	-	-	None	-	-	None
Storage Length	100	-	-	-	-	-	-	-	-	-	-	-
Veh in Median Storage, #	-	0	-	-	0	-	-	0	-	-	0	-
Grade, %	-	0	-	-	0	-	-	0	-	-	0	-
Peak Hour Factor	92	92	92	92	92	92	92	92	92	92	92	92
Heavy Vehicles, %	2	2	2	2	2	2	2	2	2	2	2	2
Mvmt Flow	80	0	23	0	0	0	10	442	0	0	162	47

Major/Minor	Minor2		Minor1		Major1		Major2					
Conflicting Flow All	647	647	185	624	671	442	209	0	0	442	0	0
Stage 1	185	185	-	462	462	-	-	-	-	-	-	-
Stage 2	462	462	-	162	209	-	-	-	-	-	-	-
Critical Hdwy	7.12	6.52	6.22	7.12	6.52	6.22	4.12	-	-	4.12	-	-
Critical Hdwy Stg 1	6.12	5.52	-	6.12	5.52	-	-	-	-	-	-	-
Critical Hdwy Stg 2	6.12	5.52	-	6.12	5.52	-	-	-	-	-	-	-
Follow-up Hdwy	3.518	4.018	3.318	3.518	4.018	3.318	2.218	-	-	2.218	-	-
Pot Cap-1 Maneuver	384	390	857	398	378	615	1362	-	-	1118	-	-
Stage 1	816	746	-	580	565	-	-	-	-	-	-	-
Stage 2	580	565	-	840	729	-	-	-	-	-	-	-
Platoon blocked, %								-	-	-	-	-
Mov Cap-1 Maneuver	380	386	857	384	374	615	1362	-	-	1118	-	-
Mov Cap-2 Maneuver	380	386	-	384	374	-	-	-	-	-	-	-
Stage 1	816	746	-	574	559	-	-	-	-	-	-	-
Stage 2	574	559	-	818	729	-	-	-	-	-	-	-

Approach	EB	WB	NB	SB
HCM Ctrl Dly, s/v	15.29	0	0.17	0
HCM LOS	C	A		

Minor Lane/Major Mvmt	NBL	NBT	NBR	EBLn1	EBLn2	WBLn1	SBL	SBT	SBR
Capacity (veh/h)	39	-	-	380	857	-	1118	-	-
HCM Lane V/C Ratio	0.007	-	-	0.212	0.027	-	-	-	-
HCM Ctrl Dly (s/v)	7.7	0	-	17	9.3	0	0	-	-
HCM Lane LOS	A	A	-	C	A	A	A	-	-
HCM 95th %tile Q(veh)	0	-	-	0.8	0.1	-	0	-	-

Intersection						
Int Delay, s/veh	3.8					
Movement	SEL	SER	NEL	NET	SWT	SWR
Lane Configurations						
Traffic Vol, veh/h	3	47	67	70	70	3
Future Vol, veh/h	3	47	67	70	70	3
Conflicting Peds, #/hr	0	0	0	0	0	0
Sign Control	Stop	Stop	Free	Free	Free	Free
RT Channelized	-	None	-	None	-	None
Storage Length	0	-	0	-	-	-
Veh in Median Storage, #	0	-	-	0	0	-
Grade, %	0	-	-	0	0	-
Peak Hour Factor	75	75	70	70	81	81
Heavy Vehicles, %	0	2	2	0	2	0
Mvmt Flow	4	63	96	100	86	4

Major/Minor	Minor2	Major1		Major2	
Conflicting Flow All	380	88	90	0	0
Stage 1	88	-	-	-	-
Stage 2	291	-	-	-	-
Critical Hdwy	6.4	6.22	4.12	-	-
Critical Hdwy Stg 1	5.4	-	-	-	-
Critical Hdwy Stg 2	5.4	-	-	-	-
Follow-up Hdwy	3.5	3.318	2.218	-	-
Pot Cap-1 Maneuver	626	970	1505	-	-
Stage 1	940	-	-	-	-
Stage 2	763	-	-	-	-
Platoon blocked, %				-	-
Mov Cap-1 Maneuver	586	970	1505	-	-
Mov Cap-2 Maneuver	586	-	-	-	-
Stage 1	880	-	-	-	-
Stage 2	763	-	-	-	-

Approach	SE	NE	SW
HCM Ctrl Dly, s/v	9.15	3.69	0
HCM LOS	A		

Minor Lane/Major Mvmt	NEL	NET SELn1	SWT	SWR
Capacity (veh/h)	1505	- 933	-	-
HCM Lane V/C Ratio	0.064	- 0.071	-	-
HCM Ctrl Dly (s/v)	7.6	- 9.2	-	-
HCM Lane LOS	A	- A	-	-
HCM 95th %tile Q(veh)	0.2	- 0.2	-	-

HCM Unsignalized Intersection Capacity Analysis

110: Mountain View Blvd & 2260 South

02/05/2026

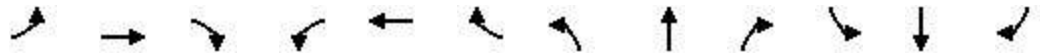

Movement	EBL	EBT	EBR	WBL	WBT	WBR	NBL	NBT	NBR	SBL	SBT	SBR
Lane Configurations		↕			↕			↕			↕	
Sign Control		Yield			Yield			Yield			Yield	
Traffic Volume (vph)	7	7	0	7	14	15	0	7	6	8	5	1
Future Volume (vph)	7	7	0	7	14	15	0	7	6	8	5	1
Peak Hour Factor	0.60	0.60	0.60	0.86	0.86	0.86	0.69	0.69	0.69	0.75	0.75	0.75
Hourly flow rate (vph)	12	12	0	8	16	17	0	10	9	11	7	1

Direction, Lane #	EB 1	WB 1	NB 1	SB 1
Volume Total (vph)	24	41	19	19
Volume Left (vph)	12	8	0	11
Volume Right (vph)	0	17	9	1
Hadj (s)	0.13	-0.18	-0.25	0.12
Departure Headway (s)	4.2	3.8	3.8	4.2
Degree Utilization, x	0.03	0.04	0.02	0.02
Capacity (veh/h)	852	925	917	845
Control Delay (s/veh)	7.3	7.0	6.9	7.3
Approach Delay (s/veh)	7.3	7.0	6.9	7.3
Approach LOS	A	A	A	A

Intersection Summary			
Delay		7.1	
Level of Service		A	
Intersection Capacity Utilization		17.4%	ICU Level of Service A
Analysis Period (min)		15	

2050 Build Condition - AM

Intersection						
Int Delay, s/veh	2.6					
Movement	WBL	WBR	NBT	NBR	SBL	SBT
Lane Configurations	Y		B			A
Traffic Vol, veh/h	12	27	105	198	69	233
Future Vol, veh/h	12	27	105	198	69	233
Conflicting Peds, #/hr	0	0	0	0	0	0
Sign Control	Stop	Stop	Free	Free	Free	Free
RT Channelized	-	None	-	None	-	None
Storage Length	0	-	-	-	-	-
Veh in Median Storage, #	0	-	0	-	-	0
Grade, %	0	-	0	-	-	0
Peak Hour Factor	34	34	68	68	54	54
Heavy Vehicles, %	0	0	0	2	0	4
Mvmt Flow	35	79	154	291	128	431

Major/Minor	Minor1	Major1	Major2		
Conflicting Flow All	987	300	0	0	446
Stage 1	300	-	-	-	-
Stage 2	687	-	-	-	-
Critical Hdwy	6.4	6.2	-	-	4.1
Critical Hdwy Stg 1	5.4	-	-	-	-
Critical Hdwy Stg 2	5.4	-	-	-	-
Follow-up Hdwy	3.5	3.3	-	-	2.2
Pot Cap-1 Maneuver	277	744	-	-	1125
Stage 1	756	-	-	-	-
Stage 2	503	-	-	-	-
Platoon blocked, %			-	-	-
Mov Cap-1 Maneuver	235	744	-	-	1125
Mov Cap-2 Maneuver	235	-	-	-	-
Stage 1	756	-	-	-	-
Stage 2	428	-	-	-	-

Approach	WB	NB	SB
HCM Ctrl Dly, s/v	15.81	0	1.97
HCM LOS	C		

Minor Lane/Major Mvmt	NBT	NBRWBLn1	SBL	SBT
Capacity (veh/h)	-	-	447	411
HCM Lane V/C Ratio	-	-	0.257	0.114
HCM Ctrl Dly (s/v)	-	-	15.8	8.6
HCM Lane LOS	-	-	C	A
HCM 95th %tile Q(veh)	-	-	1	0.4

Intersection				
Intersection Delay, s/veh	3.3			
Intersection LOS	A			
Approach	EB	WB	NB	SB
Entry Lanes	1	1	1	1
Conflicting Circle Lanes	1	1	1	1
Adj Approach Flow, veh/h	45	54	92	37
Demand Flow Rate, veh/h	48	57	94	40
Vehicles Circulating, veh/h	67	14	70	50
Vehicles Exiting, veh/h	23	150	45	21
Ped Vol Crossing Leg, #/h	0	0	0	0
Ped Cap Adj	1.000	1.000	1.000	1.000
Approach Delay, s/veh	3.3	3.1	3.5	3.2
Approach LOS	A	A	A	A
Lane	Left	Left	Left	Left
Designated Moves	LTR	LTR	LTR	LTR
Assumed Moves	LTR	LTR	LTR	LTR
RT Channelized				
Lane Util	1.000	1.000	1.000	1.000
Follow-Up Headway, s	2.609	2.609	2.609	2.609
Critical Headway, s	4.976	4.976	4.976	4.976
A (Intercept)	1380	1380	1380	1380
B (Slope)	1.02e-3	1.02e-3	1.02e-3	1.02e-3
Entry Flow, veh/h	48	57	94	40
Cap Entry Lane, veh/h	1289	1360	1285	1311
Entry HV Adj Factor	0.928	0.947	0.979	0.925
Flow Entry, veh/h	45	54	92	37
Cap Entry, veh/h	1196	1289	1257	1213
V/C Ratio	0.037	0.042	0.073	0.031
Control Delay, s/veh	3.3	3.1	3.5	3.2
LOS	A	A	A	A
95th %tile Queue, veh	0	0	0	0

Intersection						
Int Delay, s/veh	3.1					
Movement	EBT	EBR	WBL	WBT	NBL	NBR
Lane Configurations						
Traffic Vol, veh/h	116	21	10	176	68	27
Future Vol, veh/h	116	21	10	176	68	27
Conflicting Peds, #/hr	0	0	0	0	0	0
Sign Control	Free	Free	Free	Free	Stop	Stop
RT Channelized	-	None	-	None	-	None
Storage Length	-	-	-	-	0	-
Veh in Median Storage, #	0	-	-	0	0	-
Grade, %	0	-	-	0	0	-
Peak Hour Factor	82	82	75	75	70	70
Heavy Vehicles, %	9	5	11	4	2	4
Mvmt Flow	141	26	13	235	97	39

Major/Minor	Major1	Major2	Minor1		
Conflicting Flow All	0	0	167	0	416 154
Stage 1	-	-	-	-	154 -
Stage 2	-	-	-	-	261 -
Critical Hdwy	-	-	4.21	-	6.42 6.24
Critical Hdwy Stg 1	-	-	-	-	5.42 -
Critical Hdwy Stg 2	-	-	-	-	5.42 -
Follow-up Hdwy	-	-	2.299	-	3.518 3.336
Pot Cap-1 Maneuver	-	-	1358	-	593 886
Stage 1	-	-	-	-	874 -
Stage 2	-	-	-	-	782 -
Platoon blocked, %	-	-	-	-	-
Mov Cap-1 Maneuver	-	-	1358	-	587 886
Mov Cap-2 Maneuver	-	-	-	-	587 -
Stage 1	-	-	-	-	874 -
Stage 2	-	-	-	-	774 -

Approach	EB	WB	NB
HCM Ctrl Dly, s/v	0	0.41	12.01
HCM LOS			B

Minor Lane/Major Mvmt	NBLn1	EBT	EBR	WBL	WBT
Capacity (veh/h)	649	-	-	97	-
HCM Lane V/C Ratio	0.209	-	-	0.01	-
HCM Ctrl Dly (s/v)	12	-	-	7.7	0
HCM Lane LOS	B	-	-	A	A
HCM 95th %tile Q(veh)	0.8	-	-	0	-

Intersection												
Int Delay, s/veh	3											
Movement	EBL	EBT	EBR	WBL	WBT	WBR	NBL	NBT	NBR	SBL	SBT	SBR
Lane Configurations		↕			↕			↕			↕	
Traffic Vol, veh/h	4	185	3	2	258	22	6	0	3	45	0	47
Future Vol, veh/h	4	185	3	2	258	22	6	0	3	45	0	47
Conflicting Peds, #/hr	0	0	0	0	0	0	0	0	0	0	0	0
Sign Control	Free	Free	Free	Free	Free	Free	Stop	Stop	Stop	Stop	Stop	Stop
RT Channelized	-	-	None	-	-	None	-	-	None	-	-	None
Storage Length	-	-	-	-	-	-	-	-	-	-	-	-
Veh in Median Storage, #	-	0	-	-	0	-	-	0	-	-	0	-
Grade, %	-	0	-	-	0	-	-	0	-	-	0	-
Peak Hour Factor	88	88	88	79	79	79	67	67	67	67	67	67
Heavy Vehicles, %	0	6	0	0	3	25	0	0	0	14	0	10
Mvmt Flow	5	210	3	3	327	28	9	0	4	67	0	70

Major/Minor	Major1			Major2			Minor1			Minor2		
Conflicting Flow All	354	0	0	214	0	0	553	581	212	565	568	341
Stage 1	-	-	-	-	-	-	221	221	-	346	346	-
Stage 2	-	-	-	-	-	-	332	359	-	219	223	-
Critical Hdwy	4.1	-	-	4.1	-	-	7.1	6.5	6.2	7.24	6.5	6.3
Critical Hdwy Stg 1	-	-	-	-	-	-	6.1	5.5	-	6.24	5.5	-
Critical Hdwy Stg 2	-	-	-	-	-	-	6.1	5.5	-	6.24	5.5	-
Follow-up Hdwy	2.2	-	-	2.2	-	-	3.5	4	3.3	3.626	4	3.39
Pot Cap-1 Maneuver	1216	-	-	1369	-	-	447	428	833	418	435	684
Stage 1	-	-	-	-	-	-	786	724	-	646	639	-
Stage 2	-	-	-	-	-	-	686	630	-	757	723	-
Platoon blocked, %		-	-		-	-						
Mov Cap-1 Maneuver	1216	-	-	1369	-	-	399	425	833	413	432	684
Mov Cap-2 Maneuver	-	-	-	-	-	-	399	425	-	413	432	-
Stage 1	-	-	-	-	-	-	783	721	-	644	638	-
Stage 2	-	-	-	-	-	-	614	629	-	749	720	-

Approach	EB			WB			NB			SB		
HCM Ctrl Dly, s/v	0.17			0.05			12.68			14.44		
HCM LOS							B			B		

Minor Lane/Major Mvmt	NBLn1	EBL	EBT	EBR	WBL	WBT	WBR	SBLn1
Capacity (veh/h)	482	37	-	-	13	-	-	518
HCM Lane V/C Ratio	0.028	0.004	-	-	0.002	-	-	0.265
HCM Ctrl Dly (s/v)	12.7	8	0	-	7.6	0	-	14.4
HCM Lane LOS	B	A	A	-	A	A	-	B
HCM 95th %tile Q(veh)	0.1	0	-	-	0	-	-	1.1

HCM 7th Signalized Intersection Summary

50: 1100 West & 1500 South

02/05/2026

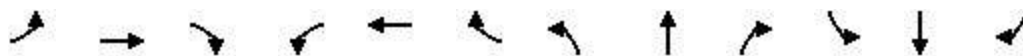

Movement	EBL	EBT	EBR	WBL	WBT	WBR	NBL	NBT	NBR	SBL	SBT	SBR
Lane Configurations	↖	↗		↖	↗		↖	↑	↗	↖	↗	
Traffic Volume (veh/h)	37	200	53	185	175	31	48	344	315	19	175	19
Future Volume (veh/h)	37	200	53	185	175	31	48	344	315	19	175	19
Initial Q (Qb), veh	0	0	0	0	0	0	0	0	0	0	0	0
Lane Width Adj.	1.00	1.00	1.00	1.00	1.00	1.00	1.00	1.00	1.00	1.00	1.00	1.00
Ped-Bike Adj(A_pbT)	1.00		1.00	1.00		1.00	1.00		1.00	1.00		1.00
Parking Bus, Adj	1.00	1.00	1.00	1.00	1.00	1.00	1.00	1.00	1.00	1.00	1.00	1.00
Work Zone On Approach		No			No			No			No	
Adj Sat Flow, veh/h/ln	1707	1870	1767	1856	1856	1826	1737	1870	1856	1900	1900	1633
Adj Flow Rate, veh/h	39	213	56	243	230	41	73	521	477	33	307	33
Peak Hour Factor	0.94	0.94	0.94	0.76	0.76	0.76	0.66	0.66	0.66	0.57	0.57	0.57
Percent Heavy Veh, %	13	2	9	3	3	5	11	2	3	0	0	18
Cap, veh/h	450	562	148	477	604	108	425	759	638	261	684	74
Arrive On Green	0.39	0.39	0.39	0.39	0.39	0.39	0.41	0.41	0.41	0.41	0.41	0.41
Sat Flow, veh/h	1012	1427	375	1101	1533	273	966	1870	1572	573	1686	181
Grp Volume(v), veh/h	39	0	269	243	0	271	73	521	477	33	0	340
Grp Sat Flow(s),veh/h/ln	1012	0	1803	1101	0	1806	966	1870	1572	573	0	1867
Q Serve(g_s), s	1.3	0.0	4.8	9.1	0.0	4.8	2.7	10.3	11.6	2.3	0.0	5.9
Cycle Q Clear(g_c), s	6.1	0.0	4.8	13.8	0.0	4.8	8.6	10.3	11.6	12.6	0.0	5.9
Prop In Lane	1.00		0.21	1.00		0.15	1.00		1.00	1.00		0.10
Lane Grp Cap(c), veh/h	450	0	710	477	0	711	425	759	638	261	0	758
V/C Ratio(X)	0.09	0.00	0.38	0.51	0.00	0.38	0.17	0.69	0.75	0.13	0.00	0.45
Avail Cap(c_a), veh/h	615	0	1003	656	0	1005	592	1082	910	360	0	1081
HCM Platoon Ratio	1.00	1.00	1.00	1.00	1.00	1.00	1.00	1.00	1.00	1.00	1.00	1.00
Upstream Filter(I)	1.00	0.00	1.00	1.00	0.00	1.00	1.00	1.00	1.00	1.00	0.00	1.00
Uniform Delay (d), s/veh	11.9	0.0	9.7	14.6	0.0	9.7	12.8	11.0	11.4	16.2	0.0	9.7
Incr Delay (d2), s/veh	0.1	0.0	0.3	0.8	0.0	0.3	0.2	1.1	2.1	0.2	0.0	0.4
Initial Q Delay(d3), s/veh	0.0	0.0	0.0	0.0	0.0	0.0	0.0	0.0	0.0	0.0	0.0	0.0
%ile BackOfQ(95%),veh/ln	0.5	0.0	2.8	3.6	0.0	2.8	0.9	6.3	6.2	0.5	0.0	3.5
Unsig. Movement Delay, s/veh												
LnGrp Delay(d), s/veh	12.0	0.0	10.0	15.5	0.0	10.0	13.0	12.1	13.5	16.4	0.0	10.1
LnGrp LOS	B		B	B		B	B	B	B	B		B
Approach Vol, veh/h		308			514			1071			373	
Approach Delay, s/veh		10.3			12.6			12.8			10.7	
Approach LOS		B			B			B			B	
Timer - Assigned Phs		2		4		6		8				
Phs Duration (G+Y+Rc), s		22.7		22.2		22.7		22.2				
Change Period (Y+Rc), s		4.5		4.5		4.5		4.5				
Max Green Setting (Gmax), s		26.0		25.0		26.0		25.0				
Max Q Clear Time (g_c+I1), s		13.6		8.1		14.6		15.8				
Green Ext Time (p_c), s		4.6		1.6		1.8		1.9				
Intersection Summary												
HCM 7th Control Delay, s/veh				12.1								
HCM 7th LOS				B								

HCM 7th Signalized Intersection Summary

60: 800 West & 1500 South

02/05/2026



Movement	EBL	EBT	EBR	WBL	WBT	WBR	NBL	NBT	NBR	SBL	SBT	SBR
Lane Configurations	↖	↗		↖	↗		↖	↗		↖	↗	
Traffic Volume (veh/h)	83	278	66	53	291	74	33	107	60	50	62	58
Future Volume (veh/h)	83	278	66	53	291	74	33	107	60	50	62	58
Initial Q (Qb), veh	0	0	0	0	0	0	0	0	0	0	0	0
Lane Width Adj.	1.00	1.00	1.00	1.00	1.00	1.00	1.00	1.00	1.00	1.00	1.00	1.00
Ped-Bike Adj(A_pbT)	1.00		1.00	1.00		1.00	1.00		1.00	1.00		1.00
Parking Bus, Adj	1.00	1.00	1.00	1.00	1.00	1.00	1.00	1.00	1.00	1.00	1.00	1.00
Work Zone On Approach		No		No		No		No		No		No
Adj Sat Flow, veh/h/ln	1870	1885	1841	1856	1856	1870	1900	1870	1900	1900	1841	1900
Adj Flow Rate, veh/h	111	371	88	69	378	96	46	151	85	77	95	89
Peak Hour Factor	0.75	0.75	0.75	0.77	0.77	0.77	0.71	0.71	0.71	0.65	0.65	0.65
Percent Heavy Veh, %	2	1	4	3	3	2	0	2	0	0	4	0
Cap, veh/h	451	656	156	464	636	161	450	307	173	412	239	224
Arrive On Green	0.45	0.45	0.45	0.45	0.45	0.45	0.27	0.27	0.27	0.27	0.27	0.27
Sat Flow, veh/h	920	1473	349	925	1428	363	1219	1124	633	1162	874	819
Grp Volume(v), veh/h	111	0	459	69	0	474	46	0	236	77	0	184
Grp Sat Flow(s),veh/h/ln	920	0	1822	925	0	1790	1219	0	1756	1162	0	1693
Q Serve(g_s), s	3.3	0.0	6.0	1.9	0.0	6.4	1.0	0.0	3.6	1.9	0.0	2.8
Cycle Q Clear(g_c), s	9.7	0.0	6.0	7.9	0.0	6.4	3.9	0.0	3.6	5.5	0.0	2.8
Prop In Lane	1.00		0.19	1.00		0.20	1.00		0.36	1.00		0.48
Lane Grp Cap(c), veh/h	451	0	811	464	0	797	450	0	480	412	0	462
V/C Ratio(X)	0.25	0.00	0.57	0.15	0.00	0.59	0.10	0.00	0.49	0.19	0.00	0.40
Avail Cap(c_a), veh/h	661	0	1226	675	0	1205	1052	0	1347	986	0	1299
HCM Platoon Ratio	1.00	1.00	1.00	1.00	1.00	1.00	1.00	1.00	1.00	1.00	1.00	1.00
Upstream Filter(l)	1.00	0.00	1.00	1.00	0.00	1.00	1.00	0.00	1.00	1.00	0.00	1.00
Uniform Delay (d), s/veh	10.3	0.0	6.6	9.5	0.0	6.7	11.0	0.0	9.8	12.1	0.0	9.5
Incr Delay (d2), s/veh	0.3	0.0	0.6	0.1	0.0	0.7	0.1	0.0	0.8	0.2	0.0	0.6
Initial Q Delay(d3), s/veh	0.0	0.0	0.0	0.0	0.0	0.0	0.0	0.0	0.0	0.0	0.0	0.0
%ile BackOfQ(95%),veh/lr0.9	0.0	2.5	0.5	0.0	2.7	0.4	0.0	1.9	0.7	0.0	1.5	
Unsig. Movement Delay, s/veh												
LnGrp Delay(d), s/veh	10.6	0.0	7.2	9.6	0.0	7.4	11.1	0.0	10.5	12.3	0.0	10.0
LnGrp LOS	B		A	A		A	B		B	B		B
Approach Vol, veh/h		570			543			282			261	
Approach Delay, s/veh		7.9			7.7			10.6			10.7	
Approach LOS		A			A			B			B	
Timer - Assigned Phs		2		4		6		8				
Phs Duration (G+Y+Rc), s		13.2		18.7		13.2		18.7				
Change Period (Y+Rc), s		4.5		4.5		4.5		4.5				
Max Green Setting (Gmax), s		24.5		21.5		24.5		21.5				
Max Q Clear Time (g_c+1), s		5.9		11.7		7.5		9.9				
Green Ext Time (p_c), s		1.4		2.5		1.2		2.7				
Intersection Summary												
HCM 7th Control Delay, s/veh			8.7									
HCM 7th LOS			A									

Intersection												
Int Delay, s/veh	3.5											
Movement	EBL	EBT	EBR	WBL	WBT	WBR	NBL	NBT	NBR	SBL	SBT	SBR
Lane Configurations		↕			↕			↕			↕	
Traffic Vol, veh/h	1	16	2	49	6	9	0	25	75	20	31	5
Future Vol, veh/h	1	16	2	49	6	9	0	25	75	20	31	5
Conflicting Peds, #/hr	0	0	0	0	0	0	0	0	0	0	0	0
Sign Control	Stop	Stop	Stop	Stop	Stop	Stop	Free	Free	Free	Free	Free	Free
RT Channelized	-	-	None	-	-	None	-	-	None	-	-	None
Storage Length	-	-	-	-	-	-	-	-	-	-	-	-
Veh in Median Storage, #	-	0	-	-	0	-	-	0	-	-	0	-
Grade, %	-	0	-	-	0	-	-	0	-	-	0	-
Peak Hour Factor	71	71	71	78	78	78	45	45	45	68	68	68
Heavy Vehicles, %	0	7	100	0	0	13	0	5	2	6	4	25
Mvmt Flow	1	23	3	63	8	12	0	56	167	29	46	7

Major/Minor	Minor2		Minor1		Major1			Major2				
Conflicting Flow All	167	330	49	255	251	139	53	0	0	222	0	0
Stage 1	108	108	-	139	139	-	-	-	-	-	-	-
Stage 2	59	222	-	116	112	-	-	-	-	-	-	-
Critical Hdwy	7.1	6.57	7.2	7.1	6.5	6.33	4.1	-	-	4.16	-	-
Critical Hdwy Stg 1	6.1	5.57	-	6.1	5.5	-	-	-	-	-	-	-
Critical Hdwy Stg 2	6.1	5.57	-	6.1	5.5	-	-	-	-	-	-	-
Follow-up Hdwy	3.5	4.063	4.2	3.5	4	3.417	2.2	-	-	2.254	-	-
Pot Cap-1 Maneuver	801	581	799	703	656	881	1566	-	-	1323	-	-
Stage 1	902	796	-	869	786	-	-	-	-	-	-	-
Stage 2	957	710	-	894	807	-	-	-	-	-	-	-
Platoon blocked, %								-	-	-	-	-
Mov Cap-1 Maneuver	763	568	799	658	641	881	1566	-	-	1323	-	-
Mov Cap-2 Maneuver	763	568	-	658	641	-	-	-	-	-	-	-
Stage 1	882	778	-	869	786	-	-	-	-	-	-	-
Stage 2	935	710	-	845	788	-	-	-	-	-	-	-

Approach	EB		WB		NB		SB	
HCM Ctrl Dly, s/v	11.35		11.02		0		2.78	
HCM LOS	B		B					

Minor Lane/Major Mvmt	NBL	NBT	NBR	EBLn1	WBLn1	SBL	SBT	SBR
Capacity (veh/h)	1566	-	-	594	680	625	-	-
HCM Lane V/C Ratio	-	-	-	0.045	0.121	0.022	-	-
HCM Ctrl Dly (s/v)	0	-	-	11.3	11	7.8	0	-
HCM Lane LOS	A	-	-	B	B	A	A	-
HCM 95th %tile Q(veh)	0	-	-	0.1	0.4	0.1	-	-

Intersection	
Intersection Delay, s/veh	7.5
Intersection LOS	A

Movement	EBL	EBT	EBR	WBL	WBT	WBR	NBL	NBT	NBR	SBL	SBT	SBR
Lane Configurations		↕			↕			↕			↕	
Traffic Vol, veh/h	0	18	3	28	16	5	15	0	57	7	1	0
Future Vol, veh/h	0	18	3	28	16	5	15	0	57	7	1	0
Peak Hour Factor	0.79	0.79	0.79	0.60	0.60	0.60	0.68	0.68	0.68	0.88	0.88	0.88
Heavy Vehicles, %	0	6	33	8	0	0	8	0	0	0	0	0
Mvmt Flow	0	23	4	47	27	8	22	0	84	8	1	0
Number of Lanes	0	1	0	0	1	0	0	1	0	0	1	0

Approach	EB	WB	NB	SB
Opposing Approach	WB	EB	SB	NB
Opposing Lanes	1	1	1	1
Conflicting Approach Left	SB	NB	EB	WB
Conflicting Lanes Left	1	1	1	1
Conflicting Approach Right	NB	SB	WB	EB
Conflicting Lanes Right	1	1	1	1
HCM Control Delay, s/veh	7.4	7.8	7.3	7.5
HCM LOS	A	A	A	A

Lane	NBLn1	EBLn1	WBLn1	SBLn1
Vol Left, %	21%	0%	57%	88%
Vol Thru, %	0%	86%	33%	13%
Vol Right, %	79%	14%	10%	0%
Sign Control	Stop	Stop	Stop	Stop
Traffic Vol by Lane	72	21	49	8
LT Vol	15	0	28	7
Through Vol	0	18	16	1
RT Vol	57	3	5	0
Lane Flow Rate	106	27	82	9
Geometry Grp	1	1	1	1
Degree of Util (X)	0.112	0.031	0.098	0.011
Departure Headway (Hd)	3.798	4.18	4.31	4.347
Convergence, Y/N	Yes	Yes	Yes	Yes
Cap	934	849	827	814
Service Time	1.863	2.244	2.357	2.426
HCM Lane V/C Ratio	0.113	0.032	0.099	0.011
HCM Control Delay, s/veh	7.3	7.4	7.8	7.5
HCM Lane LOS	A	A	A	A
HCM 95th-tile Q	0.4	0.1	0.3	0

Intersection												
Int Delay, s/veh	7.2											
Movement	EBL	EBT	EBR	WBL	WBT	WBR	NBL	NBT	NBR	SBL	SBT	SBR
Lane Configurations												
Traffic Vol, veh/h	197	0	126	0	0	0	96	101	4	2	285	370
Future Vol, veh/h	197	0	126	0	0	0	96	101	4	2	285	370
Conflicting Peds, #/hr	0	0	0	0	0	0	0	0	0	0	0	0
Sign Control	Stop	Stop	Stop	Stop	Stop	Stop	Free	Free	Free	Free	Free	Free
RT Channelized	-	-	None	-	-	None	-	-	None	-	-	None
Storage Length	100	-	-	-	-	-	-	-	-	-	-	100
Veh in Median Storage, #	-	0	-	-	0	-	-	0	-	-	0	-
Grade, %	-	0	-	-	0	-	-	0	-	-	0	-
Peak Hour Factor	92	92	92	92	92	92	92	92	92	92	92	92
Heavy Vehicles, %	2	2	2	2	2	2	2	2	2	2	2	2
Mvmt Flow	214	0	137	0	0	0	104	110	4	2	310	402

Major/Minor	Minor2		Minor1		Major1		Major2					
Conflicting Flow All	633	637	310	635	1037	112	712	0	0	114	0	0
Stage 1	314	314	-	321	321	-	-	-	-	-	-	-
Stage 2	318	323	-	314	716	-	-	-	-	-	-	-
Critical Hdwy	7.12	6.52	6.22	7.12	6.52	6.22	4.12	-	-	4.12	-	-
Critical Hdwy Stg 1	6.12	5.52	-	6.12	5.52	-	-	-	-	-	-	-
Critical Hdwy Stg 2	6.12	5.52	-	6.12	5.52	-	-	-	-	-	-	-
Follow-up Hdwy	3.518	4.018	3.318	3.518	4.018	3.318	2.218	-	-	2.218	-	-
Pot Cap-1 Maneuver	393	395	730	391	231	941	888	-	-	1475	-	-
Stage 1	697	656	-	691	652	-	-	-	-	-	-	-
Stage 2	693	650	-	697	434	-	-	-	-	-	-	-
Platoon blocked, %								-	-	-	-	-
Mov Cap-1 Maneuver	342	344	730	277	202	941	888	-	-	1475	-	-
Mov Cap-2 Maneuver	342	344	-	277	202	-	-	-	-	-	-	-
Stage 1	695	654	-	604	570	-	-	-	-	-	-	-
Stage 2	606	569	-	565	433	-	-	-	-	-	-	-

Approach	EB		WB		NB		SB	
HCM Ctrl Dly, s/v	23.55		0		4.58		0.02	
HCM LOS	C		A					

Minor Lane/Major Mvmt	NBL	NBT	NBR	EBLn1	EBLn2	WBLn1	SBL	SBT	SBR
Capacity (veh/h)	831	-	-	342	730	-	13	-	-
HCM Lane V/C Ratio	0.118	-	-	0.625	0.188	-	0.001	-	-
HCM Ctrl Dly (s/v)	9.6	0	-	31.5	11.1	0	7.4	0	-
HCM Lane LOS	A	A	-	D	B	A	A	A	-
HCM 95th %tile Q(veh)	0.4	-	-	4	0.7	-	0	-	-

Intersection						
Int Delay, s/veh	5					
Movement	SEL	SER	NEL	NET	SWT	SWR
Lane Configurations						
Traffic Vol, veh/h	5	75	60	59	41	5
Future Vol, veh/h	5	75	60	59	41	5
Conflicting Peds, #/hr	0	0	0	0	0	0
Sign Control	Stop	Stop	Free	Free	Free	Free
RT Channelized	-	None	-	None	-	None
Storage Length	0	-	0	-	-	-
Veh in Median Storage, #	0	-	-	0	0	-
Grade, %	0	-	-	0	0	-
Peak Hour Factor	63	63	75	75	67	67
Heavy Vehicles, %	25	2	0	0	0	25
Mvmt Flow	8	119	80	79	61	7

Major/Minor	Minor2	Major1		Major2	
Conflicting Flow All	304	65	69	0	0
Stage 1	65	-	-	-	-
Stage 2	239	-	-	-	-
Critical Hdwy	6.65	6.22	4.1	-	-
Critical Hdwy Stg 1	5.65	-	-	-	-
Critical Hdwy Stg 2	5.65	-	-	-	-
Follow-up Hdwy	3.725	3.318	2.2	-	-
Pot Cap-1 Maneuver	643	999	1545	-	-
Stage 1	902	-	-	-	-
Stage 2	750	-	-	-	-
Platoon blocked, %				-	-
Mov Cap-1 Maneuver	609	999	1545	-	-
Mov Cap-2 Maneuver	609	-	-	-	-
Stage 1	856	-	-	-	-
Stage 2	750	-	-	-	-

Approach	SE	NE	SW
HCM Ctrl Dly, s/v	9.32	3.76	0
HCM LOS	A		

Minor Lane/Major Mvmt	NEL	NET SELn1	SWT	SWR
Capacity (veh/h)	1545	-	961	-
HCM Lane V/C Ratio	0.052	-	0.132	-
HCM Ctrl Dly (s/v)	7.5	-	9.3	-
HCM Lane LOS	A	-	A	-
HCM 95th %tile Q(veh)	0.2	-	0.5	-

HCM Unsignalized Intersection Capacity Analysis
 110: Mountain View Blvd & 2260 South

02/05/2026

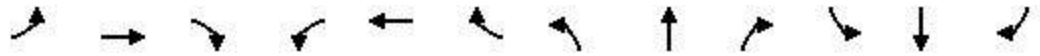

Movement	EBL	EBT	EBR	WBL	WBT	WBR	NBL	NBT	NBR	SBL	SBT	SBR
Lane Configurations		↕			↕			↕			↕	
Sign Control		Yield			Yield			Yield			Yield	
Traffic Volume (vph)	6	7	0	2	1	8	0	6	6	8	3	3
Future Volume (vph)	6	7	0	2	1	8	0	6	6	8	3	3
Peak Hour Factor	0.55	0.55	0.55	0.42	0.42	0.42	0.50	0.50	0.50	0.33	0.33	0.33
Hourly flow rate (vph)	11	13	0	5	2	19	0	12	12	24	9	9

Direction, Lane #	EB 1	WB 1	NB 1	SB 1
Volume Total (vph)	24	26	24	42
Volume Left (vph)	11	5	0	24
Volume Right (vph)	0	19	12	9
Hadj (s)	0.55	-0.06	-0.13	0.23
Departure Headway (s)	4.6	4.0	3.9	4.3
Degree Utilization, x	0.03	0.03	0.03	0.05
Capacity (veh/h)	762	878	891	829
Control Delay (s/veh)	7.8	7.1	7.0	7.5
Approach Delay (s/veh)	7.8	7.1	7.0	7.5
Approach LOS	A	A	A	A

Intersection Summary

Delay	7.4
Level of Service	A
Intersection Capacity Utilization	17.5%
ICU Level of Service	A
Analysis Period (min)	15

2050 Build Condition - PM

Intersection						
Int Delay, s/veh	1					
Movement	WBL	WBR	NBT	NBR	SBL	SBT
Lane Configurations	Y		B			A
Traffic Vol, veh/h	11	16	179	12	18	250
Future Vol, veh/h	11	16	179	12	18	250
Conflicting Peds, #/hr	0	0	0	0	0	0
Sign Control	Stop	Stop	Free	Free	Free	Free
RT Channelized	-	None	-	None	-	None
Storage Length	0	-	-	-	-	-
Veh in Median Storage, #	0	-	0	-	-	0
Grade, %	0	-	0	-	-	0
Peak Hour Factor	75	75	81	81	91	91
Heavy Vehicles, %	10	7	2	0	8	0
Mvmt Flow	15	21	221	15	20	275

Major/Minor	Minor1	Major1	Major2		
Conflicting Flow All	543	228	0	0	236
Stage 1	228	-	-	-	-
Stage 2	314	-	-	-	-
Critical Hdwy	6.5	6.27	-	-	4.18
Critical Hdwy Stg 1	5.5	-	-	-	-
Critical Hdwy Stg 2	5.5	-	-	-	-
Follow-up Hdwy	3.59	3.363	-	-	2.272
Pot Cap-1 Maneuver	487	799	-	-	1297
Stage 1	791	-	-	-	-
Stage 2	723	-	-	-	-
Platoon blocked, %			-	-	-
Mov Cap-1 Maneuver	479	799	-	-	1297
Mov Cap-2 Maneuver	479	-	-	-	-
Stage 1	791	-	-	-	-
Stage 2	710	-	-	-	-

Approach	WB	NB	SB
HCM Ctrl Dly, s/v	11.08	0	0.53
HCM LOS	B		

Minor Lane/Major Mvmt	NBT	NBRWBLn1	SBL	SBT
Capacity (veh/h)	-	-	628	121
HCM Lane V/C Ratio	-	-	0.057	0.015
HCM Ctrl Dly (s/v)	-	-	11.1	7.8
HCM Lane LOS	-	-	B	A
HCM 95th %tile Q(veh)	-	-	0.2	0

Intersection				
Intersection Delay, s/veh	3.9			
Intersection LOS	A			
Approach	EB	WB	NB	SB
Entry Lanes	1	1	1	1
Conflicting Circle Lanes	1	1	1	1
Adj Approach Flow, veh/h	39	259	62	70
Demand Flow Rate, veh/h	41	263	64	73
Vehicles Circulating, veh/h	135	3	103	117
Vehicles Exiting, veh/h	55	164	73	149
Ped Vol Crossing Leg, #/h	0	0	0	0
Ped Cap Adj	1.000	1.000	1.000	1.000
Approach Delay, s/veh	3.4	4.2	3.4	3.6
Approach LOS	A	A	A	A
Lane	Left	Left	Left	Left
Designated Moves	LTR	LTR	LTR	LTR
Assumed Moves	LTR	LTR	LTR	LTR
RT Channelized				
Lane Util	1.000	1.000	1.000	1.000
Follow-Up Headway, s	2.609	2.609	2.609	2.609
Critical Headway, s	4.976	4.976	4.976	4.976
A (Intercept)	1380	1380	1380	1380
B (Slope)	1.02e-3	1.02e-3	1.02e-3	1.02e-3
Entry Flow, veh/h	41	263	64	73
Cap Entry Lane, veh/h	1202	1376	1242	1225
Entry HV Adj Factor	0.959	0.985	0.969	0.959
Flow Entry, veh/h	39	259	62	70
Cap Entry, veh/h	1153	1355	1203	1174
V/C Ratio	0.034	0.191	0.052	0.060
Control Delay, s/veh	3.4	4.2	3.4	3.6
LOS	A	A	A	A
95th %tile Queue, veh	0	1	0	0

Intersection						
Int Delay, s/veh	1.6					
Movement	EBT	EBR	WBL	WBT	NBL	NBR
Lane Configurations						
Traffic Vol, veh/h	238	71	25	228	38	12
Future Vol, veh/h	238	71	25	228	38	12
Conflicting Peds, #/hr	0	0	0	0	0	0
Sign Control	Free	Free	Free	Free	Stop	Stop
RT Channelized	-	None	-	None	-	None
Storage Length	-	-	-	-	0	-
Veh in Median Storage, #	0	-	-	0	0	-
Grade, %	0	-	-	0	0	-
Peak Hour Factor	88	88	89	89	75	75
Heavy Vehicles, %	2	0	5	1	0	0
Mvmt Flow	270	81	28	256	51	16

Major/Minor	Major1	Major2	Minor1		
Conflicting Flow All	0	0	351	0	623 311
Stage 1	-	-	-	-	311 -
Stage 2	-	-	-	-	312 -
Critical Hdwy	-	-	4.15	-	6.4 6.2
Critical Hdwy Stg 1	-	-	-	-	5.4 -
Critical Hdwy Stg 2	-	-	-	-	5.4 -
Follow-up Hdwy	-	-	2.245	-	3.5 3.3
Pot Cap-1 Maneuver	-	-	1191	-	453 734
Stage 1	-	-	-	-	748 -
Stage 2	-	-	-	-	746 -
Platoon blocked, %	-	-	-	-	-
Mov Cap-1 Maneuver	-	-	1191	-	440 734
Mov Cap-2 Maneuver	-	-	-	-	440 -
Stage 1	-	-	-	-	748 -
Stage 2	-	-	-	-	726 -

Approach	EB	WB	NB
HCM Ctrl Dly, s/v	0	0.8	13.56
HCM LOS			B

Minor Lane/Major Mvmt	NBLn1	EBT	EBR	WBL	WBT
Capacity (veh/h)	487	-	-	178	-
HCM Lane V/C Ratio	0.137	-	-	0.024	-
HCM Ctrl Dly (s/v)	13.6	-	-	8.1	0
HCM Lane LOS	B	-	-	A	A
HCM 95th %tile Q(veh)	0.5	-	-	0.1	-

Intersection												
Int Delay, s/veh	1.8											
Movement	EBL	EBT	EBR	WBL	WBT	WBR	NBL	NBT	NBR	SBL	SBT	SBR
Lane Configurations		↕			↕			↕			↕	
Traffic Vol, veh/h	34	298	3	18	434	18	0	0	9	13	0	23
Future Vol, veh/h	34	298	3	18	434	18	0	0	9	13	0	23
Conflicting Peds, #/hr	0	0	0	0	0	0	0	0	0	0	0	0
Sign Control	Free	Free	Free	Free	Free	Free	Stop	Stop	Stop	Stop	Stop	Stop
RT Channelized	-	-	None	-	-	None	-	-	None	-	-	None
Storage Length	-	-	-	-	-	-	-	-	-	-	-	-
Veh in Median Storage, #	-	0	-	-	0	-	-	0	-	-	0	-
Grade, %	-	0	-	-	0	-	-	0	-	-	0	-
Peak Hour Factor	86	86	86	90	90	90	40	40	40	60	60	60
Heavy Vehicles, %	4	2	0	0	0	0	0	0	0	0	0	0
Mvmt Flow	40	347	3	20	482	20	0	0	23	22	0	38

Major/Minor	Major1			Major2			Minor1			Minor2		
Conflicting Flow All	502	0	0	350	0	0	950	970	348	958	961	492
Stage 1	-	-	-	-	-	-	427	427	-	532	532	-
Stage 2	-	-	-	-	-	-	522	542	-	426	429	-
Critical Hdwy	4.14	-	-	4.1	-	-	7.1	6.5	6.2	7.1	6.5	6.2
Critical Hdwy Stg 1	-	-	-	-	-	-	6.1	5.5	-	6.1	5.5	-
Critical Hdwy Stg 2	-	-	-	-	-	-	6.1	5.5	-	6.1	5.5	-
Follow-up Hdwy	2.236	-	-	2.2	-	-	3.5	4	3.3	3.5	4	3.3
Pot Cap-1 Maneuver	1052	-	-	1220	-	-	242	255	700	239	258	581
Stage 1	-	-	-	-	-	-	609	588	-	535	529	-
Stage 2	-	-	-	-	-	-	541	523	-	611	587	-
Platoon blocked, %	-	-	-	-	-	-	-	-	-	-	-	-
Mov Cap-1 Maneuver	1052	-	-	1220	-	-	211	238	700	216	241	581
Mov Cap-2 Maneuver	-	-	-	-	-	-	211	238	-	216	241	-
Stage 1	-	-	-	-	-	-	581	561	-	522	517	-
Stage 2	-	-	-	-	-	-	494	511	-	563	560	-

Approach	EB			WB			NB			SB		
HCM Ctrl Dly, s/v	0.87			0.31			10.32			16.98		
HCM LOS							B			C		

Minor Lane/Major Mvmt	NBLn1	EBL	EBT	EBR	WBL	WBT	WBR	SBLn1
Capacity (veh/h)	700	182	-	-	68	-	-	360
HCM Lane V/C Ratio	0.032	0.038	-	-	0.016	-	-	0.167
HCM Ctrl Dly (s/v)	10.3	8.6	0	-	8	0	-	17
HCM Lane LOS	B	A	A	-	A	A	-	C
HCM 95th %tile Q(veh)	0.1	0.1	-	-	0	-	-	0.6

HCM 7th Signalized Intersection Summary

50: 1100 West & 1500 South

02/05/2026



Movement	EBL	EBT	EBR	WBL	WBT	WBR	NBL	NBT	NBR	SBL	SBT	SBR
Lane Configurations												
Traffic Volume (veh/h)	50	286	44	126	352	78	67	488	208	42	105	76
Future Volume (veh/h)	50	286	44	126	352	78	67	488	208	42	105	76
Initial Q (Qb), veh	0	0	0	0	0	0	0	0	0	0	0	0
Lane Width Adj.	1.00	1.00	1.00	1.00	1.00	1.00	1.00	1.00	1.00	1.00	1.00	1.00
Ped-Bike Adj(A_pbT)	1.00		1.00	1.00		1.00	1.00		1.00	1.00		1.00
Parking Bus, Adj	1.00	1.00	1.00	1.00	1.00	1.00	1.00	1.00	1.00	1.00	1.00	1.00
Work Zone On Approach		No			No			No			No	
Adj Sat Flow, veh/h/ln	1796	1870	1900	1856	1900	1841	1900	1885	1826	1856	1856	1856
Adj Flow Rate, veh/h	60	345	53	164	457	101	74	536	229	51	127	92
Peak Hour Factor	0.83	0.83	0.83	0.77	0.77	0.77	0.91	0.91	0.91	0.83	0.83	0.83
Percent Heavy Veh, %	7	2	0	3	0	4	0	1	5	3	3	3
Cap, veh/h	301	670	103	417	638	141	498	709	582	250	376	273
Arrive On Green	0.42	0.42	0.42	0.42	0.42	0.42	0.38	0.38	0.38	0.38	0.38	0.38
Sat Flow, veh/h	818	1583	243	979	1507	333	1181	1885	1547	697	1000	725
Grp Volume(v), veh/h	60	0	398	164	0	558	74	536	229	51	0	219
Grp Sat Flow(s),veh/h/ln	818	0	1827	979	0	1840	1181	1885	1547	697	0	1725
Q Serve(g_s), s	2.9	0.0	7.2	6.7	0.0	11.3	2.1	11.1	4.9	3.1	0.0	4.1
Cycle Q Clear(g_c), s	14.2	0.0	7.2	13.9	0.0	11.3	6.2	11.1	4.9	14.2	0.0	4.1
Prop In Lane	1.00		0.13	1.00		0.18	1.00		1.00	1.00		0.42
Lane Grp Cap(c), veh/h	301	0	773	417	0	778	498	709	582	250	0	649
V/C Ratio(X)	0.20	0.00	0.52	0.39	0.00	0.72	0.15	0.76	0.39	0.20	0.00	0.34
Avail Cap(c_a), veh/h	411	0	1018	549	0	1026	606	883	725	314	0	808
HCM Platoon Ratio	1.00	1.00	1.00	1.00	1.00	1.00	1.00	1.00	1.00	1.00	1.00	1.00
Upstream Filter(I)	1.00	0.00	1.00	1.00	0.00	1.00	1.00	1.00	1.00	1.00	0.00	1.00
Uniform Delay (d), s/veh	16.6	0.0	9.5	14.7	0.0	10.7	12.2	12.2	10.2	18.4	0.0	10.0
Incr Delay (d2), s/veh	0.3	0.0	0.5	0.6	0.0	1.6	0.1	2.9	0.4	0.4	0.0	0.3
Initial Q Delay(d3), s/veh	0.0	0.0	0.0	0.0	0.0	0.0	0.0	0.0	0.0	0.0	0.0	0.0
%ile BackOfQ(95%),veh/ln	0.9	0.0	4.1	2.4	0.0	6.8	0.9	7.6	2.5	0.8	0.0	2.3
Unsig. Movement Delay, s/veh												
LnGrp Delay(d), s/veh	16.9	0.0	10.1	15.3	0.0	12.4	12.3	15.1	10.7	18.8	0.0	10.3
LnGrp LOS	B		B	B		B	B	B	B	B		B
Approach Vol, veh/h		458			722			839				270
Approach Delay, s/veh		11.0			13.0			13.7				11.9
Approach LOS		B			B			B				B
Timer - Assigned Phs		2		4		6		8				
Phs Duration (G+Y+Rc), s		21.4		23.5		21.4		23.5				
Change Period (Y+Rc), s		4.5		4.5		4.5		4.5				
Max Green Setting (Gmax), s		21.0		25.0		21.0		25.0				
Max Q Clear Time (g_c+11), s		13.1		16.2		16.2		15.9				
Green Ext Time (p_c), s		2.9		1.9		0.7		3.1				
Intersection Summary												
HCM 7th Control Delay, s/veh				12.7								
HCM 7th LOS				B								

HCM 7th Signalized Intersection Summary

60: 800 West & 1500 South

02/05/2026



Movement	EBL	EBT	EBR	WBL	WBT	WBR	NBL	NBT	NBR	SBL	SBT	SBR
Lane Configurations	↖	↗		↖	↗		↖	↗		↖	↗	
Traffic Volume (veh/h)	64	286	54	116	355	77	49	93	97	62	86	63
Future Volume (veh/h)	64	286	54	116	355	77	49	93	97	62	86	63
Initial Q (Qb), veh	0	0	0	0	0	0	0	0	0	0	0	0
Lane Width Adj.	1.00	1.00	1.00	1.00	1.00	1.00	1.00	1.00	1.00	1.00	1.00	1.00
Ped-Bike Adj(A_pbT)	1.00		1.00	1.00		1.00	1.00		1.00	1.00		1.00
Parking Bus, Adj	1.00	1.00	1.00	1.00	1.00	1.00	1.00	1.00	1.00	1.00	1.00	1.00
Work Zone On Approach		No		No		No		No		No		No
Adj Sat Flow, veh/h/ln	1900	1885	1900	1900	1870	1870	1870	1900	1885	1900	1900	1841
Adj Flow Rate, veh/h	81	362	68	147	449	97	54	102	107	119	165	121
Peak Hour Factor	0.79	0.79	0.79	0.79	0.79	0.79	0.91	0.91	0.91	0.52	0.52	0.52
Percent Heavy Veh, %	0	1	0	0	2	2	2	0	1	0	0	4
Cap, veh/h	384	684	128	472	660	143	385	253	266	448	304	223
Arrive On Green	0.44	0.44	0.44	0.44	0.44	0.44	0.30	0.30	0.30	0.30	0.30	0.30
Sat Flow, veh/h	874	1543	290	973	1490	322	1093	849	891	1191	1019	747
Grp Volume(v), veh/h	81	0	430	147	0	546	54	0	209	119	0	286
Grp Sat Flow(s),veh/h/ln	874	0	1833	973	0	1812	1093	0	1740	1191	0	1766
Q Serve(g_s), s	2.8	0.0	5.9	4.5	0.0	8.4	1.5	0.0	3.3	3.1	0.0	4.7
Cycle Q Clear(g_c), s	11.2	0.0	5.9	10.4	0.0	8.4	6.2	0.0	3.3	6.4	0.0	4.7
Prop In Lane	1.00		0.16	1.00		0.18	1.00		0.51	1.00		0.42
Lane Grp Cap(c), veh/h	384	0	812	472	0	803	385	0	519	448	0	527
V/C Ratio(X)	0.21	0.00	0.53	0.31	0.00	0.68	0.14	0.00	0.40	0.27	0.00	0.54
Avail Cap(c_a), veh/h	537	0	1132	642	0	1120	828	0	1225	932	0	1243
HCM Platoon Ratio	1.00	1.00	1.00	1.00	1.00	1.00	1.00	1.00	1.00	1.00	1.00	1.00
Upstream Filter(l)	1.00	0.00	1.00	1.00	0.00	1.00	1.00	0.00	1.00	1.00	0.00	1.00
Uniform Delay (d), s/veh	12.2	0.0	7.1	10.9	0.0	7.7	12.8	0.0	9.7	12.3	0.0	10.2
Incr Delay (d2), s/veh	0.3	0.0	0.5	0.4	0.0	1.0	0.2	0.0	0.5	0.3	0.0	0.9
Initial Q Delay(d3), s/veh	0.0	0.0	0.0	0.0	0.0	0.0	0.0	0.0	0.0	0.0	0.0	0.0
%ile BackOfQ(95%),veh/ln	0.8	0.0	2.7	1.4	0.0	3.9	0.6	0.0	1.8	1.2	0.0	2.6
Unsig. Movement Delay, s/veh												
LnGrp Delay(d), s/veh	12.5	0.0	7.6	11.2	0.0	8.7	13.0	0.0	10.2	12.6	0.0	11.1
LnGrp LOS	B		A	B		A	B		B	B		B
Approach Vol, veh/h		511			693			263			405	
Approach Delay, s/veh		8.4			9.3			10.8			11.5	
Approach LOS		A			A			B			B	
Timer - Assigned Phs		2		4		6		8				
Phs Duration (G+Y+Rc), s		14.9		19.9		14.9		19.9				
Change Period (Y+Rc), s		4.5		4.5		4.5		4.5				
Max Green Setting (Gmax), s		24.5		21.5		24.5		21.5				
Max Q Clear Time (g_c+1), s		8.2		13.2		8.4		12.4				
Green Ext Time (p_c), s		1.3		2.0		2.0		3.0				
Intersection Summary												
HCM 7th Control Delay, s/veh			9.7									
HCM 7th LOS			A									

Intersection												
Int Delay, s/veh	6.4											
Movement	EBL	EBT	EBR	WBL	WBT	WBR	NBL	NBT	NBR	SBL	SBT	SBR
Lane Configurations		↕			↕			↕			↕	
Traffic Vol, veh/h	0	15	0	41	18	28	1	9	33	14	2	1
Future Vol, veh/h	0	15	0	41	18	28	1	9	33	14	2	1
Conflicting Peds, #/hr	0	0	0	0	0	0	0	0	0	0	0	0
Sign Control	Stop	Stop	Stop	Stop	Stop	Stop	Free	Free	Free	Free	Free	Free
RT Channelized	-	-	None	-	-	None	-	-	None	-	-	None
Storage Length	-	-	-	-	-	-	-	-	-	-	-	-
Veh in Median Storage, #	-	0	-	-	0	-	-	0	-	-	0	-
Grade, %	-	0	-	-	0	-	-	0	-	-	0	-
Peak Hour Factor	65	65	65	66	66	66	50	50	50	54	54	54
Heavy Vehicles, %	0	0	0	0	6	4	0	0	0	0	50	0
Mvmt Flow	0	23	0	62	27	42	2	18	66	26	4	2

Major/Minor	Minor2		Minor1			Major1			Major2			
Conflicting Flow All	92	144	5	122	112	51	6	0	0	84	0	0
Stage 1	56	56	-	55	55	-	-	-	-	-	-	-
Stage 2	36	88	-	67	57	-	-	-	-	-	-	-
Critical Hdwy	7.1	6.5	6.2	7.1	6.56	6.24	4.1	-	-	4.1	-	-
Critical Hdwy Stg 1	6.1	5.5	-	6.1	5.56	-	-	-	-	-	-	-
Critical Hdwy Stg 2	6.1	5.5	-	6.1	5.56	-	-	-	-	-	-	-
Follow-up Hdwy	3.5	4	3.3	3.5	4.054	3.336	2.2	-	-	2.2	-	-
Pot Cap-1 Maneuver	897	750	1085	857	770	1011	1629	-	-	1526	-	-
Stage 1	961	852	-	962	841	-	-	-	-	-	-	-
Stage 2	985	826	-	948	839	-	-	-	-	-	-	-
Platoon blocked, %								-	-	-	-	-
Mov Cap-1 Maneuver	813	737	1085	816	756	1011	1629	-	-	1526	-	-
Mov Cap-2 Maneuver	813	737	-	816	756	-	-	-	-	-	-	-
Stage 1	944	837	-	961	840	-	-	-	-	-	-	-
Stage 2	912	825	-	906	825	-	-	-	-	-	-	-

Approach	EB		WB			NB			SB		
HCM Ctrl Dly, s/v	10.04		9.98			0.17			6.09		
HCM LOS	B		A								

Minor Lane/Major Mvmt	NBL	NBT	NBR	EBLn1	WBLn1	SBL	SBT	SBR
Capacity (veh/h)	36	-	-	737	855	1390	-	-
HCM Lane V/C Ratio	0.001	-	-	0.031	0.154	0.017	-	-
HCM Ctrl Dly (s/v)	7.2	0	-	10	10	7.4	0	-
HCM Lane LOS	A	A	-	B	A	A	A	-
HCM 95th %tile Q(veh)	0	-	-	0.1	0.5	0.1	-	-

Intersection	
Intersection Delay, s/veh	7.6
Intersection LOS	A

Movement	EBL	EBT	EBR	WBL	WBT	WBR	NBL	NBT	NBR	SBL	SBT	SBR
Lane Configurations		↕			↕			↕			↕	
Traffic Vol, veh/h	2	28	14	45	34	12	11	5	55	7	3	2
Future Vol, veh/h	2	28	14	45	34	12	11	5	55	7	3	2
Peak Hour Factor	0.70	0.70	0.70	0.78	0.78	0.78	0.88	0.88	0.88	0.43	0.43	0.43
Heavy Vehicles, %	0	0	0	0	3	0	0	0	0	0	0	0
Mvmt Flow	3	40	20	58	44	15	13	6	63	16	7	5
Number of Lanes	0	1	0	0	1	0	0	1	0	0	1	0

Approach	EB	WB	NB	SB
Opposing Approach	WB	EB	SB	NB
Opposing Lanes	1	1	1	1
Conflicting Approach Left	SB	NB	EB	WB
Conflicting Lanes Left	1	1	1	1
Conflicting Approach Right	NB	SB	WB	EB
Conflicting Lanes Right	1	1	1	1
HCM Control Delay, s/veh	7.4	7.9	7.3	7.5
HCM LOS	A	A	A	A

Lane	NBLn1	EBLn1	WBLn1	SBLn1
Vol Left, %	15%	5%	49%	58%
Vol Thru, %	7%	64%	37%	25%
Vol Right, %	77%	32%	13%	17%
Sign Control	Stop	Stop	Stop	Stop
Traffic Vol by Lane	71	44	91	12
LT Vol	11	2	45	7
Through Vol	5	28	34	3
RT Vol	55	14	12	2
Lane Flow Rate	81	63	117	28
Geometry Grp	1	1	1	1
Degree of Util (X)	0.085	0.07	0.135	0.033
Departure Headway (Hd)	3.797	3.998	4.158	4.292
Convergence, Y/N	Yes	Yes	Yes	Yes
Cap	926	886	856	820
Service Time	1.891	2.067	2.211	2.391
HCM Lane V/C Ratio	0.087	0.071	0.137	0.034
HCM Control Delay, s/veh	7.3	7.4	7.9	7.5
HCM Lane LOS	A	A	A	A
HCM 95th-tile Q	0.3	0.2	0.5	0.1

Intersection												
Int Delay, s/veh	2.1											
Movement	EBL	EBT	EBR	WBL	WBT	WBR	NBL	NBT	NBR	SBL	SBT	SBR
Lane Configurations												
Traffic Vol, veh/h	74	0	21	0	0	0	9	407	0	0	149	43
Future Vol, veh/h	74	0	21	0	0	0	9	407	0	0	149	43
Conflicting Peds, #/hr	0	0	0	0	0	0	0	0	0	0	0	0
Sign Control	Stop	Stop	Stop	Stop	Stop	Stop	Free	Free	Free	Free	Free	Free
RT Channelized	-	-	None	-	-	None	-	-	None	-	-	None
Storage Length	100	-	-	-	-	-	-	-	-	-	-	100
Veh in Median Storage, #	-	0	-	-	0	-	-	0	-	-	0	-
Grade, %	-	0	-	-	0	-	-	0	-	-	0	-
Peak Hour Factor	92	92	92	92	92	92	92	92	92	92	92	92
Heavy Vehicles, %	2	2	2	2	2	2	2	2	2	2	2	2
Mvmt Flow	80	0	23	0	0	0	10	442	0	0	162	47

Major/Minor	Minor2		Minor1		Major1			Major2				
Conflicting Flow All	624	624	162	624	671	442	209	0	0	442	0	0
Stage 1	162	162	-	462	462	-	-	-	-	-	-	-
Stage 2	462	462	-	162	209	-	-	-	-	-	-	-
Critical Hdwy	7.12	6.52	6.22	7.12	6.52	6.22	4.12	-	-	4.12	-	-
Critical Hdwy Stg 1	6.12	5.52	-	6.12	5.52	-	-	-	-	-	-	-
Critical Hdwy Stg 2	6.12	5.52	-	6.12	5.52	-	-	-	-	-	-	-
Follow-up Hdwy	3.518	4.018	3.318	3.518	4.018	3.318	2.218	-	-	2.218	-	-
Pot Cap-1 Maneuver	398	402	883	398	378	615	1362	-	-	1118	-	-
Stage 1	840	764	-	580	565	-	-	-	-	-	-	-
Stage 2	580	565	-	840	729	-	-	-	-	-	-	-
Platoon blocked, %								-	-	-	-	-
Mov Cap-1 Maneuver	394	398	883	384	374	615	1362	-	-	1118	-	-
Mov Cap-2 Maneuver	394	398	-	384	374	-	-	-	-	-	-	-
Stage 1	840	764	-	574	559	-	-	-	-	-	-	-
Stage 2	574	559	-	818	729	-	-	-	-	-	-	-

Approach	EB		WB		NB		SB	
HCM Ctrl Dly, s/v	14.85		0		0.17		0	
HCM LOS	B		A					

Minor Lane/Major Mvmt	NBL	NBT	NBR	EBLn1	EBLn2	WBLn1	SBL	SBT	SBR
Capacity (veh/h)	39	-	-	394	883	-	1118	-	-
HCM Lane V/C Ratio	0.007	-	-	0.204	0.026	-	-	-	-
HCM Ctrl Dly (s/v)	7.7	0	-	16.5	9.2	0	0	-	-
HCM Lane LOS	A	A	-	C	A	A	A	-	-
HCM 95th %tile Q(veh)	0	-	-	0.8	0.1	-	0	-	-

Intersection						
Int Delay, s/veh	3.8					
Movement	SEL	SER	NEL	NET	SWT	SWR
Lane Configurations						
Traffic Vol, veh/h	3	47	67	70	70	3
Future Vol, veh/h	3	47	67	70	70	3
Conflicting Peds, #/hr	0	0	0	0	0	0
Sign Control	Stop	Stop	Free	Free	Free	Free
RT Channelized	-	None	-	None	-	None
Storage Length	0	-	0	-	-	-
Veh in Median Storage, #	0	-	-	0	0	-
Grade, %	0	-	-	0	0	-
Peak Hour Factor	75	75	70	70	81	81
Heavy Vehicles, %	0	2	2	0	2	0
Mvmt Flow	4	63	96	100	86	4

Major/Minor	Minor2	Major1		Major2	
Conflicting Flow All	380	88	90	0	0
Stage 1	88	-	-	-	-
Stage 2	291	-	-	-	-
Critical Hdwy	6.4	6.22	4.12	-	-
Critical Hdwy Stg 1	5.4	-	-	-	-
Critical Hdwy Stg 2	5.4	-	-	-	-
Follow-up Hdwy	3.5	3.318	2.218	-	-
Pot Cap-1 Maneuver	626	970	1505	-	-
Stage 1	940	-	-	-	-
Stage 2	763	-	-	-	-
Platoon blocked, %				-	-
Mov Cap-1 Maneuver	586	970	1505	-	-
Mov Cap-2 Maneuver	586	-	-	-	-
Stage 1	880	-	-	-	-
Stage 2	763	-	-	-	-

Approach	SE	NE	SW
HCM Ctrl Dly, s/v	9.15	3.69	0
HCM LOS	A		

Minor Lane/Major Mvmt	NEL	NET SELn1	SWT	SWR
Capacity (veh/h)	1505	-	933	-
HCM Lane V/C Ratio	0.064	-	0.071	-
HCM Ctrl Dly (s/v)	7.6	-	9.2	-
HCM Lane LOS	A	-	A	-
HCM 95th %tile Q(veh)	0.2	-	0.2	-

HCM Unsignalized Intersection Capacity Analysis

110: Mountain View Blvd & 2260 South

02/05/2026

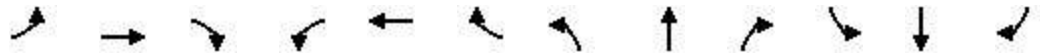

Movement	EBL	EBT	EBR	WBL	WBT	WBR	NBL	NBT	NBR	SBL	SBT	SBR
Lane Configurations		↕			↕			↕			↕	
Sign Control		Yield			Yield			Yield			Yield	
Traffic Volume (vph)	7	7	0	7	14	15	0	7	6	8	5	1
Future Volume (vph)	7	7	0	7	14	15	0	7	6	8	5	1
Peak Hour Factor	0.60	0.60	0.60	0.86	0.86	0.86	0.69	0.69	0.69	0.75	0.75	0.75
Hourly flow rate (vph)	12	12	0	8	16	17	0	10	9	11	7	1

Direction, Lane #	EB 1	WB 1	NB 1	SB 1
Volume Total (vph)	24	41	19	19
Volume Left (vph)	12	8	0	11
Volume Right (vph)	0	17	9	1
Hadj (s)	0.13	-0.18	-0.25	0.12
Departure Headway (s)	4.2	3.8	3.8	4.2
Degree Utilization, x	0.03	0.04	0.02	0.02
Capacity (veh/h)	852	925	917	845
Control Delay (s/veh)	7.3	7.0	6.9	7.3
Approach Delay (s/veh)	7.3	7.0	6.9	7.3
Approach LOS	A	A	A	A

Intersection Summary			
Delay		7.1	
Level of Service		A	
Intersection Capacity Utilization		17.4%	ICU Level of Service A
Analysis Period (min)		15	

APPENDIX B: CRASH ANALYSIS RESULTS

DRAFT

Intersection Crashes (2020 Oct-2025 Oct)

Crash Type	Crash Type Intersections															
	3-Legged				4-leg, TWSC				4-Leg AWSC				4-Leg Yield		RAB-4 Leg	
	UDOT Historic	1100S / 800W	1500S / 1600W	1950S / 625W	UDOT Historic	1500S / 1450W	1950S / 1955W	1970S / 1100W	UDOT Historic	1500S / 1100W	1500S / 800W	1900S / 1425W	UDOT Historic	2260S / Mountain View	UDOT Historic	1500S / Mountain View
Roadway Departure Involved	5 to 7%	0.0%	0.0%	0.0%	4 to 6%	0.0%	0.0%	0.0%	3.0%	0.0%	18.2%	0.0%	-	0.0%	-	0.0%
Pedestrian Involved	1.3 to 2.2%	0.0%	0.0%	0.0%	0 to 2%	0.0%	0.0%	0.0%	-	0.0%	9.1%	0.0%	-	0.0%	-	0.0%
Night Dark Condition	18 to 20%	0.0%	0.0%	0.0%	20 to 24%	0.0%	0.0%	0.0%	17.0%	33.3%	18.2%	50.0%	-	0.0%	-	0.0%
Speed Related	-	0.0%	100.0%	0.0%	-	0.0%	0.0%	0.0%	-	11.1%	9.1%	0.0%	-	0.0%	-	0.0%
Teenage Driver Involved	24 to 31%	100.0%	0.0%	0.0%	30 to 33%	0.0%	100.0%	0.0%	42.0%	22.2%	18.2%	100.0%	-	0.0%	-	0.0%
Older Driver Involved	14 to 18%	0.0%	0.0%	0.0%	17 to 20%	0.0%	0.0%	0.0%	16.0%	44.4%	18.2%	0.0%	-	0.0%	-	100.0%
Motorcycle Involved	-	0.0%	0.0%	0.0%	-	0.0%	0.0%	100.0%	-	0.0%	0.0%	0.0%	-	0.0%	-	0.0%
Commercial Motor Vehicle Involved	8.0%	0.0%	0.0%	0.0%	8 to 13%	0.0%	0.0%	0.0%	8.0%	22.2%	36.4%	0.0%	-	0.0%	-	0.0%
DUI Involved	1 to 2%	0.0%	100.0%	0.0%	1 to 2.5%	0.0%	0.0%	0.0%	1.0%	0.0%	0.0%	0.0%	-	0.0%	-	0.0%
Wild Animal Involved	-	0.0%	0.0%	0.0%	-	0.0%	0.0%	0.0%	-	0.0%	0.0%	0.0%	-	0.0%	-	0.0%
Left Turn Analysis Filter	42 to 46%	100.0%	0.0%	0.0%	28 to 32%	0.0%	0.0%	0.0%	17.0%	11.1%	9.1%	0.0%	-	0.0%	-	0.0%
Disregard Traffic Control Device Involved	3.0%	0.0%	0.0%	0.0%	4 to 10%	0.0%	0.0%	0.0%	23.0%	22.2%	9.1%	0.0%	-	0.0%	-	0.0%
Bicycle Involved	0 to 1.4%	0.0%	0.0%	0.0%	1 to 2%	0.0%	0.0%	0.0%	4.0%	0.0%	0.0%	0.0%	-	0.0%	-	0.0%

Manner of Collision	Crash Manner of Collision															
	3-Legged				4-leg, TWSC				4-Leg AWSC				4-Leg Yield		RAB-4 Leg	
	UDOT Historic	1100S / 800W	1500S / 1600W	1950S / 625W	UDOT Historic	1500S / 1450W	1950S / 1955W	1970S / 1100W	UDOT Historic	1500S / 1100W	1500S / 800W	1900S / 1425W	UDOT Historic	2260S / Mountain View	UDOT Historic	1500S / Mountain View
Front to Rear	31.4%	100.0%	100.0%	0.0%	20.0%	0.0%	0.0%	0.0%	20.4%	44.4%	27.3%	50.0%	-	0.0%	-	0.0%
Angle	46.4%	0.0%	0.0%	0.0%	63.5%	0.0%	100.0%	0.0%	68.4%	33.3%	27.3%	50.0%	-	0.0%	-	100.0%
Not Applicable/Single Vehicle	11.2%	0.0%	0.0%	0.0%	6.1%	0.0%	0.0%	100.0%	3.1%	0.0%	27.3%	0.0%	-	0.0%	-	0.0%
Sideswipe Same Direction	6.2%	0.0%	0.0%	0.0%	7.6%	0.0%	0.0%	0.0%	4.1%	22.2%	18.2%	0.0%	-	0.0%	-	0.0%
Head On (front-to-front)	1.0%	0.0%	0.0%	0.0%	1.1%	0.0%	0.0%	0.0%	1.0%	0.0%	0.0%	0.0%	-	0.0%	-	0.0%
Sideswipe Opposite Direction	3.2%	0.0%	0.0%	0.0%	0.5%	0.0%	0.0%	0.0%	1.0%	0.0%	0.0%	0.0%	-	0.0%	-	0.0%
Parked Vehicle	-	0.0%	0.0%	0.0%	-	0.0%	0.0%	0.0%	-	0.0%	0.0%	0.0%	-	0.0%	-	0.0%
Other Crashes	0.6%	0.0%	0.0%	0.0%	1.2%	0.0%	0.0%	0.0%	2.0%	0.0%	0.0%	0.0%	-	0.0%	-	0.0%
Grand Total	-	1	1	0	-	0	1	1	-	9	11	2	-	0	-	1

Crash Severity	Crash Severity															
	3-Legged				4-leg, TWSC				4-Leg AWSC				4-Leg Yield		RAB-4 Leg	
	UDOT Historic	1100S / 800W	1500S / 1600W	1950S / 625W	UDOT Historic	1500S / 1450W	1950S / 1955W	1970S / 1100W	UDOT Historic	1500S / 1100W	1500S / 800W	1900S / 1425W	UDOT Historic	2260S / Mountain View	UDOT Historic	1500S / Mountain View
Fatal	-	0.00%	0.00%	0.00%	0.21%	0.00%	0.00%	0.00%	1.02%	0.00%	0.00%	0.00%	-	0.00%	-	0.00%
Suspected Serious Injury	1.50%	0.00%	0.00%	0.00%	2.37%	0.00%	0.00%	0.00%	-	0.00%	0.00%	0.00%	-	0.00%	-	0.00%
Suspected Minor Injury	8.73%	0.00%	0.00%	0.00%	13.73%	0.00%	0.00%	100.00%	10.20%	0.00%	9.09%	50.00%	-	0.00%	-	0.00%
Possible Injury	15.46%	0.00%	100.00%	0.00%	17.44%	0.00%	0.00%	17.35%	22.22%	27.27%	0.00%	-	-	0.00%	-	0.00%
No injury/PDO	74.31%	100.00%	0.00%	0.00%	66.25%	0.00%	100.00%	71.43%	77.78%	63.64%	50.00%	-	-	0.00%	-	100.00%
Grand Total	-	1	1	0	-	0	1	1	-	9	11	2	-	0	-	1

First Harmful Event	First Harmful Event											
	3-Legged			4-leg, TWSC				4-Leg AWSC			4-Leg Yield	RAB-4 Leg
	1100S / 800W	1500S / 1600W	1950S / 625W	1500S / 1450W	1950S / 1955W	1970S / 1100W	1500S / 1100W	1500S / 800W	1900S / 1425W	2260S / Mountain View	1500S / Mountain View	
Collision With Other Motor Vehicle in Transport	100.0%	100.0%	0.0%	0.0%	100.0%	0.0%	100.0%	72.7%	100.0%	0.0%	100.0%	
Cub	0.0%	0.0%	0.0%	0.0%	0.0%	0.0%	0.0%	9.1%	0.0%	0.0%	0.0%	
Fell/Jumped From Motor Vehicle	0.0%	0.0%	0.0%	0.0%	0.0%	100.0%	0.0%	0.0%	0.0%	0.0%	0.0%	
Other Fixed Object*	0.0%	0.0%	0.0%	0.0%	0.0%	0.0%	0.0%	9.1%	0.0%	0.0%	0.0%	
Pedestrian	0.0%	0.0%	0.0%	0.0%	0.0%	0.0%	0.0%	9.1%	0.0%	0.0%	0.0%	
Grand Total	1	1	0	0	1	1	9	11	2	0	1	

Time	Time											
	3-Legged			4-leg, TWSC				4-Leg AWSC			4-Leg Yield	RAB-4 Leg
	1100S / 800W	1500S / 1600W	1950S / 625W	1500S / 1450W	1950S / 1955W	1970S / 1100W	1500S / 1100W	1500S / 800W	1900S / 1425W	2260S / Mountain View	1500S / Mountain View	
Peak AM	0.0%	0.0%	0.0%	0.0%	0.0%	0.0%	11.1%	18.2%	0.0%	0.0%	0.0%	
Peak PM	100.0%	0.0%	0.0%	0.0%	0.0%	0.0%	11.1%	9.1%	100.0%	0.0%	0.0%	
Off Peak Day	0.0%	100.0%	0.0%	0.0%	100.0%	0.0%	55.6%	45.5%	0.0%	0.0%	100.0%	
Off Peak Night	0.0%	0.0%	0.0%	0.0%	0.0%	100.0%	22.2%	27.3%	0.0%	0.0%	0.0%	
Grand Total	1	1	0	0	1	1	9	11	2	0	1	

Intersections	AADT	Total Crashes	Crash Rate (per MEV)
1100S / 800W	5170	1	0.11
1500S / MountainView	2760	1	0.20
1500S / 1600W	5430	1	0.10
1500S / 1450W	5230	0	0.00
1500S / 1100W	10760	9	0.46
1500S / 800W	10960	11	0.55
1950S / 1955W	2100	1	0.26
1900S / 1425W	1950	2	0.56
1970S / 1100W	7230	1	0.08
1950S / 625W	2310	0	0.00
2260S / MountainView	660	0	0.00

Segment Crashes (2020 Oct-2025 Oct)

Segments	Segment Number	Segment Length (miles)	AADT (2023)	Total Crashes	Crash Rate (per 100)
800W/500S to 800W/1100S	1	0.52	4700	10	224
800W/1100S to 800W/1500S	2	0.26	4700	1	45
800W/1500S to 800W/2250S	3	0.58	6900	5	68
1100W/500S to 1100W/1500S	4	0.65	5000	2	34
1100W/1500S to 1100W/1970S	5	0.32	5000	5	171
1100W/1970S to 1100W/2600S	6	0.59	5000	5	93
1500S/2095W to 1500S/MountainView	7	0.1	620	0	0
1500S/MountainView to 1500S/1600W	8	0.48	3000	3	114
1500S/1600W to 1500S/1450W	9	0.23	3000	0	0
1500S/1450W to 1500S/1100W	10	0.44	3000	0	0
1500S/1100W to 1500S/SpurLine	11	0.06	3000	0	0
1500S/SpurLine to 1500S/MainLine	12	0.26	3000	2	141
1500S/MainLine to 1500S/800W	13	0.19	3000	3	288
1500S/800W to 1500S/US-89	14	0.7	14000	11	62

Crash Type	Segments														
	UDOT Historic (Urban Arterials)	1	2	3	4	5	6	7	8	9	10	11	12	13	14
Roadway Departure Involved	9-16%	30.0%	0.0%	20.0%	0.0%	20.0%	40.0%	0.0%	66.7%	0.0%	0.0%	0.0%	0.0%	33.3%	27.3%
Pedestrian Involved	0.5-1.4%	10.0%	0.0%	0.0%	0.0%	0.0%	0.0%	0.0%	0.0%	0.0%	0.0%	0.0%	0.0%	0.0%	0.0%
Night Dark Condition	22-28%	40.0%	0.0%	20.0%	50.0%	60.0%	40.0%	0.0%	66.7%	0.0%	0.0%	0.0%	0.0%	33.3%	9.1%
Speed Related	6-16%	20.0%	0.0%	0.0%	0.0%	0.0%	0.0%	0.0%	33.3%	0.0%	0.0%	0.0%	0.0%	0.0%	0.0%
Teenage Driver Involved	16-24%	50.0%	100.0%	20.0%	50.0%	0.0%	0.0%	0.0%	66.7%	0.0%	0.0%	0.0%	50.0%	33.3%	18.2%
Older Driver Involved	11-17%	0.0%	0.0%	20.0%	0.0%	0.0%	20.0%	0.0%	0.0%	0.0%	0.0%	0.0%	0.0%	33.3%	18.2%
Motorcycle Involved	1-3%	0.0%	0.0%	0.0%	0.0%	20.0%	0.0%	0.0%	0.0%	0.0%	0.0%	0.0%	0.0%	0.0%	0.0%
Commercial Motor Vehicle Involved	4-6%	0.0%	0.0%	0.0%	0.0%	20.0%	20.0%	0.0%	0.0%	0.0%	0.0%	0.0%	0.0%	33.3%	0.0%
DUI Involved	3-5%	0.0%	0.0%	0.0%	0.0%	40.0%	0.0%	0.0%	0.0%	0.0%	0.0%	0.0%	0.0%	0.0%	0.0%
Wild Animal Involved	2-9%	0.0%	0.0%	0.0%	0.0%	0.0%	0.0%	0.0%	0.0%	0.0%	0.0%	0.0%	0.0%	0.0%	0.0%
Left Turn Analysis Filter	NA	50.0%	100.0%	20.0%	0.0%	0.0%	0.0%	0.0%	0.0%	0.0%	0.0%	0.0%	0.0%	0.0%	18.2%
Disregard Traffic Control Device Involved	NA	0.0%	0.0%	0.0%	0.0%	0.0%	0.0%	0.0%	0.0%	0.0%	0.0%	0.0%	0.0%	0.0%	27.3%
Bicycle Involved	NA	0.0%	0.0%	0.0%	0.0%	0.0%	0.0%	0.0%	0.0%	0.0%	0.0%	0.0%	0.0%	0.0%	0.0%

Manner of Collision	Crash Manner of Collision														
	UDOT Historic	1	2	3	4	5	6	7	8	9	10	11	12	13	14
Front to Rear	38-45%	10.0%	0.0%	20.0%	0.0%	0.0%	0.0%	0.0%	0.0%	0.0%	0.0%	0.0%	50.0%	33.3%	27.3%
Angle	12-15%	20.0%	100.0%	40.0%	0.0%	0.0%	0.0%	0.0%	0.0%	0.0%	0.0%	0.0%	0.0%	0.0%	18.2%
Not Applicable/Single Vehicle	15-29%	40.0%	0.0%	40.0%	0.0%	60.0%	80.0%	0.0%	33.3%	0.0%	0.0%	0.0%	0.0%	33.3%	45.5%
Sideswipe Same Direction	12-20%	20.0%	0.0%	0.0%	0.0%	0.0%	0.0%	0.0%	0.0%	0.0%	0.0%	0.0%	50.0%	33.3%	0.0%
Head On (front-to-front)		0.0%	0.0%	0.0%	0.0%	0.0%	0.0%	0.0%	0.0%	0.0%	0.0%	0.0%	0.0%	0.0%	0.0%
Sideswipe Opposite Direction	2-3%	10.0%	0.0%	0.0%	0.0%	0.0%	0.0%	0.0%	0.0%	0.0%	0.0%	0.0%	0.0%	0.0%	0.0%
Parked Vehicle	2-3%	0.0%	0.0%	0.0%	50.0%	20.0%	0.0%	0.0%	66.7%	0.0%	0.0%	0.0%	0.0%	0.0%	9.1%
Rear to Side	NA	0.0%	0.0%	0.0%	0.0%	20.0%	0.0%	0.0%	0.0%	0.0%	0.0%	0.0%	0.0%	0.0%	0.0%
Other Crashes	1-2%	0.0%	0.0%	0.0%	0.0%	0.0%	0.0%	0.0%	0.0%	0.0%	0.0%	0.0%	0.0%	0.0%	0.0%
Grand Total		10	1	5	2	5	5	0	3	0	0	0	2	3	11

Crash Severity	Crash Severity 2020-2025														
	UDOT Historic Urban 2-Lane	1	2	3	4	5	6	7	8	9	10	11	12	13	14
Fatal	0.83%	0.0%	0.0%	0.0%	0.0%	0.0%	0.0%	0.0%	0.0%	0.0%	0.0%	0.0%	0.0%	0.0%	0.0%
Suspected Serious Injury	2.45%	0.0%	0.0%	0.0%	0.0%	0.0%	0.0%	0.0%	33.3%	0.0%	0.0%	0.0%	0.0%	0.0%	0.0%
Suspected Minor Injury	10.17%	10.0%	0.0%	40.0%	0.0%	80.0%	20.0%	0.0%	33.3%	0.0%	0.0%	0.0%	0.0%	0.0%	9.1%
Possible Injury	15.47%	20.0%	0.0%	20.0%	0.0%	0.0%	20.0%	0.0%	33.3%	0.0%	0.0%	0.0%	0.0%	0.0%	0.0%
No injury/PDO	71.09%	70.0%	100.0%	40.0%	100.0%	20.0%	60.0%	0.0%	0.0%	0.0%	0.0%	0.0%	100.0%	100.0%	90.9%
Grand Total		10	1	5	2	5	5	0	3	0	0	0	2	3	11

First Harmful Event	First Harmful Event													
	1	2	3	4	5	6	7	8	9	10	11	12	13	14
Collision With Other Motor Vehicle in Transport	60.0%	100.0%	60.0%	100.0%	40.0%	20.0%	0.0%	66.7%	0.0%	0.0%	0.0%	100.0%	66.7%	54.5%
Cub	10.0%	0.0%	0.0%	0.0%	0.0%	0.0%	0.0%	0.0%	0.0%	0.0%	0.0%	0.0%	0.0%	0.0%
Fell/Jumped From Motor Vehicle	0.0%	0.0%	0.0%	0.0%	20.0%	0.0%	0.0%	0.0%	0.0%	0.0%	0.0%	0.0%	0.0%	0.0%
Other Fixed Object*	10.0%	0.0%	0.0%	0.0%	0.0%	20.0%	0.0%	0.0%	0.0%	0.0%	0.0%	0.0%	0.0%	0.0%
Pedestrian	10.0%	0.0%	0.0%	0.0%	0.0%	0.0%	0.0%	0.0%	0.0%	0.0%	0.0%	0.0%	0.0%	0.0%
Other Non-Fixed Object*	0.0%	0.0%	0.0%	0.0%	20.0%	20.0%	0.0%	0.0%	0.0%	0.0%	0.0%	0.0%	0.0%	0.0%
Other Non-Collision*	0.0%	0.0%	20.0%	0.0%	20.0%	0.0%	0.0%	0.0%	0.0%	0.0%	0.0%	0.0%	0.0%	0.0%
Utility Pole/Light Support	10.0%	0.0%	20.0%	0.0%	0.0%	20.0%	0.0%	0.0%	0.0%	0.0%	0.0%	0.0%	0.0%	9.1%
Other Post, Pole or Support	0.0%	0.0%	0.0%	0.0%	0.0%	20.0%	0.0%	0.0%	0.0%	0.0%	0.0%	0.0%	0.0%	0.0%
Animal - Domestic	0.0%	0.0%	0.0%	0.0%	0.0%	0.0%	0.0%	0.0%	0.0%	0.0%	0.0%	0.0%	0.0%	18.2%
Ditch	0.0%	0.0%	0.0%	0.0%	0.0%	0.0%	0.0%	0.0%	0.0%	0.0%	0.0%	0.0%	0.0%	9.1%
Traffic Sign Support	0.0%	0.0%	0.0%	0.0%	0.0%	0.0%	0.0%	0.0%	0.0%	0.0%	0.0%	0.0%	33.3%	9.1%
Fence	0.0%	0.0%	0.0%	0.0%	0.0%	0.0%	0.0%	33.3%	0.0%	0.0%	0.0%	0.0%	0.0%	0.0%
Grand Total	10	1	5	2	5	5	0	3	0	0	0	2	3	11

Time	Time													
	1	2	3	4	5	6	7	8	9	10	11	12	13	14
Peak AM	10.0%	100.0%	0.0%	0.0%	0.0%	0.0%	0.0%	0.0%	0.0%	0.0%	0.0%	0.0%	0.0%	0.0%
Peak PM	0.0%	0.0%	20.0%	0.0%	0.0%	0.0%	0.0%	0.0%	0.0%	0.0%	0.0%	0.0%	0.0%	18.2%
Off Peak Day	40.0%	0.0%	20.0%	50.0%	20.0%	60.0%	0.0%	33.3%	0.0%	0.0%	100.0%	66.7%	54.5%	
Off Peak Night	50.0%	0.0%	60.0%	50.0%	80.0%	40.0%	0.0%	66.7%	0.0%	0.0%	0.0%	0.0%	33.3%	27.3%
Grand Total	10	1	5	2	5	5	0	3	0	0	0	2	3	11

Rail Road Crashes (2020 Oct-2025 Oct)

Crash Type	Crash Type						
	Main Line / 500S		Spur Line / 500S		Intersections		
	Main Line / 500S	Spur Line / 500S	Main Line / 1500S	Spur Line / 1500S	Spur Line / 1100W	Main Line / 2600S	Spur Line / 2600S
Roadway Departure Involved	21.4%	0.0%	0.0%	0.0%	100.0%	0.0%	33.3%
Pedestrian Involved	0.0%	0.0%	0.0%	0.0%	0.0%	0.0%	0.0%
Night Dark Condition	28.6%	0.0%	0.0%	100.0%	100.0%	16.7%	0.0%
Speed Related	7.1%	0.0%	25.0%	0.0%	0.0%	0.0%	0.0%
Teenage Driver Involved	21.4%	0.0%	75.0%	0.0%	0.0%	33.3%	0.0%
Older Driver Involved	21.4%	0.0%	0.0%	0.0%	0.0%	0.0%	33.3%
Motorcycle Involved	7.1%	0.0%	0.0%	0.0%	0.0%	16.7%	0.0%
Commercial Motor Vehicle Involved	14.3%	0.0%	25.0%	0.0%	0.0%	16.7%	0.0%
DUI Involved	7.1%	0.0%	0.0%	0.0%	0.0%	0.0%	0.0%
Wild Animal Involved	0.0%	0.0%	0.0%	0.0%	0.0%	0.0%	0.0%
Left Turn Analysis Filter	0.0%	0.0%	0.0%	0.0%	0.0%	0.0%	0.0%
Disregard Traffic Control Device Involved	7.1%	0.0%	0.0%	100.0%	0.0%	0.0%	0.0%
Bicycle Involved	0.0%	0.0%	0.0%	0.0%	0.0%	0.0%	0.0%

Manner of Collision	Crash Manner of Collision						
	Main Line / 500S		Spur Line / 500S		Intersections		
	Main Line / 500S	Spur Line / 500S	Main Line / 1500S	Spur Line / 1500S	Spur Line / 1100W	Main Line / 2600S	Spur Line / 2600S
Front to Rear	42.9%	0.0%	100.0%	100.0%	0.0%	66.7%	33.3%
Angle	0.0%	0.0%	0.0%	0.0%	0.0%	0.0%	0.0%
Not Applicable/Single Vehicle	42.9%	0.0%	0.0%	0.0%	100.0%	0.0%	33.3%
Sideswipe Same Direction	7.1%	0.0%	0.0%	0.0%	0.0%	33.3%	33.3%
Head On (front-to-front)	0.0%	0.0%	0.0%	0.0%	0.0%	0.0%	0.0%
Sideswipe Opposite Direction	0.0%	0.0%	0.0%	0.0%	0.0%	0.0%	0.0%
Parked Vehicle	7.1%	0.0%	0.0%	0.0%	0.0%	0.0%	0.0%
Other Crashes	0.0%	0.0%	0.0%	0.0%	0.0%	0.0%	0.0%
Grand Total	14	0	4	1	1	6	3

Crash Severity	Crash Severity						
	Main Line / 500S		Spur Line / 500S		Intersections		
	Main Line / 500S	Spur Line / 500S	Main Line / 1500S	Spur Line / 1500S	Spur Line / 1100W	Main Line / 2600S	Spur Line / 2600S
Fatal	0.0%	0.0%	0.0%	0.0%	0.0%	0.0%	0.0%
Suspected Serious Injury	14.3%	0.0%	0.0%	0.0%	0.0%	0.0%	0.0%
Suspected Minor Injury	7.1%	0.0%	25.0%	0.0%	100.0%	0.0%	0.0%
Possible Injury	0.0%	0.0%	0.0%	0.0%	0.0%	33.3%	66.7%
No injury/PDO	78.6%	0.0%	75.0%	100.0%	0.0%	66.7%	33.3%
Grand Total	14	0	4	1	1	6	3

First Harmful Event	First Harmful Event						
	Main Line / 500S		Spur Line / 500S		Intersections		
	Main Line / 500S	Spur Line / 500S	Main Line / 1500S	Spur Line / 1500S	Spur Line / 1100W	Main Line / 2600S	Spur Line / 2600S
Collision With Other Motor Vehicle in Transport	57.1%	0.0%	100.0%	100.0%	0.0%	100.0%	66.7%
Fell/Jumped From Motor Vehicle	7.1%	0.0%	0.0%	0.0%	0.0%	0.0%	0.0%
Other Fixed Object*	7.1%	0.0%	0.0%	0.0%	0.0%	0.0%	33.3%
Animal- Domestic	14.3%	0.0%	0.0%	0.0%	0.0%	0.0%	0.0%
Other Post, Pole or Support	14.3%	0.0%	0.0%	0.0%	100.0%	0.0%	0.0%
Traffic Signal Support	0.0%	0.0%	0.0%	0.0%	0.0%	0.0%	0.0%
Utility Pole/Light Support	0.0%	0.0%	0.0%	0.0%	0.0%	0.0%	0.0%
Concrete Barrier	0.0%	0.0%	0.0%	0.0%	0.0%	0.0%	0.0%
Grand Total	14	0	4	1	1	6	3

Time	Time						
	Main Line / 500S		Spur Line / 500S		Intersections		
	Main Line / 500S	Spur Line / 500S	Main Line / 1500S	Spur Line / 1500S	Spur Line / 1100W	Main Line / 2600S	Spur Line / 2600S
Peak AM	7.1%	0.0%	50.0%	0.0%	0.0%	0.0%	0.0%
Peak PM	14.3%	0.0%	0.0%	0.0%	0.0%	0.0%	33.3%
Off Peak Day	35.7%	0.0%	50.0%	0.0%	0.0%	83.3%	0.0%
Off Peak Night	42.9%	0.0%	0.0%	100.0%	100.0%	16.7%	66.7%
Grand Total	14	0	4	1	1	6	3

APPENDIX C: TRAFFIC ANALYSIS ZONE INPUTS

DRAFT

Traffic Analysis Zone Inputs						
TAZ ID Number	2023			2050		
	Population	Households	Employment	Population	Households	Employment
820	43	13	38	491	173	138
821	190	66	223	851	326	215
859	0	0	0	0	0	0
860	460	145	70	2185	831	197
861	151	48	61	1893	702	573
862	1977	620	293	6439	2450	814
863	852	256	199	987	355	265
864	1207	375	816	1394	525	812
865	471	185	2359	507	226	2417
866	1427	462	527	1864	686	551
867	5	3	725	4	3	742
868	2727	831	0	2485	900	0
869	41	14	256	65	25	254
870	1063	324	299	1001	356	439
871	1100	335	341	1129	398	342
872	314	116	1407	892	357	1634
873	798	294	70	771	333	81
3547	0	0	566	0	0	612
Total	12826	4087	8250	22958	8646	10086

APPENDIX D: ARTERIAL AND COLLECTOR TYPICAL SECTIONS

DRAFT

WOODS CROSS CITY - PRINCIPAL ARTERIAL

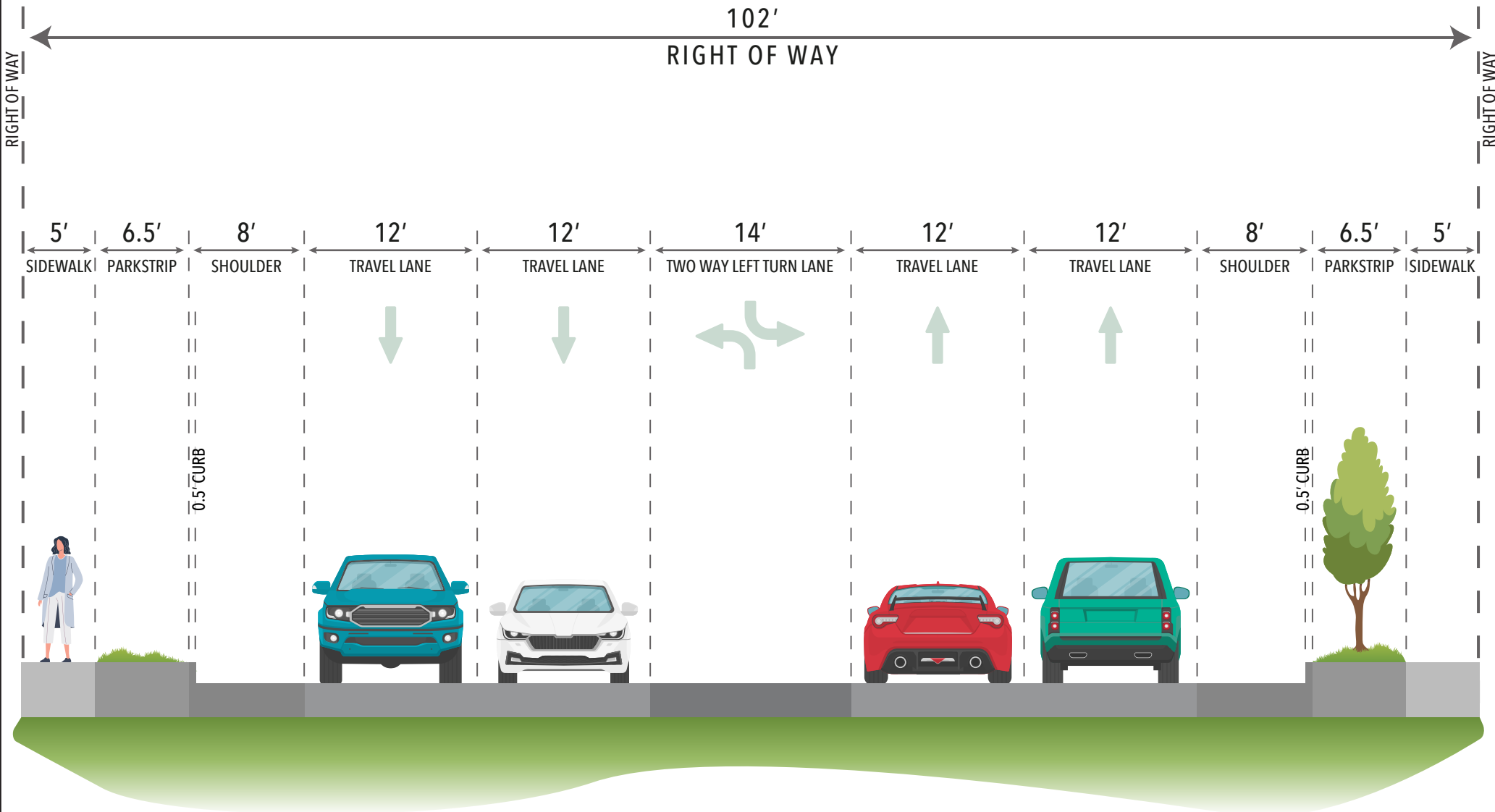

WOODS CROSS CITY - MINOR ARTERIAL

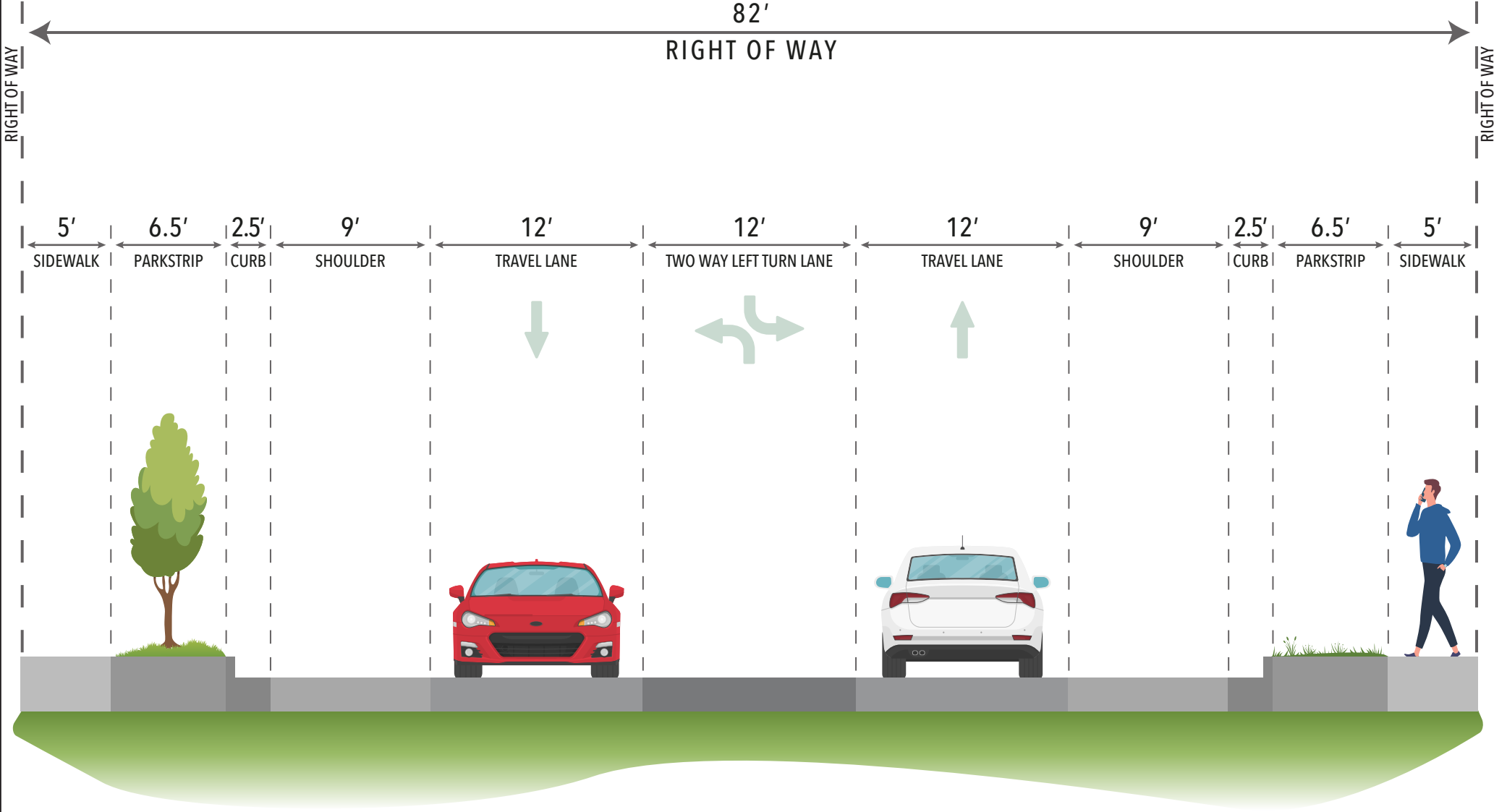

WOODS CROSS CITY - MAJOR COLLECTOR

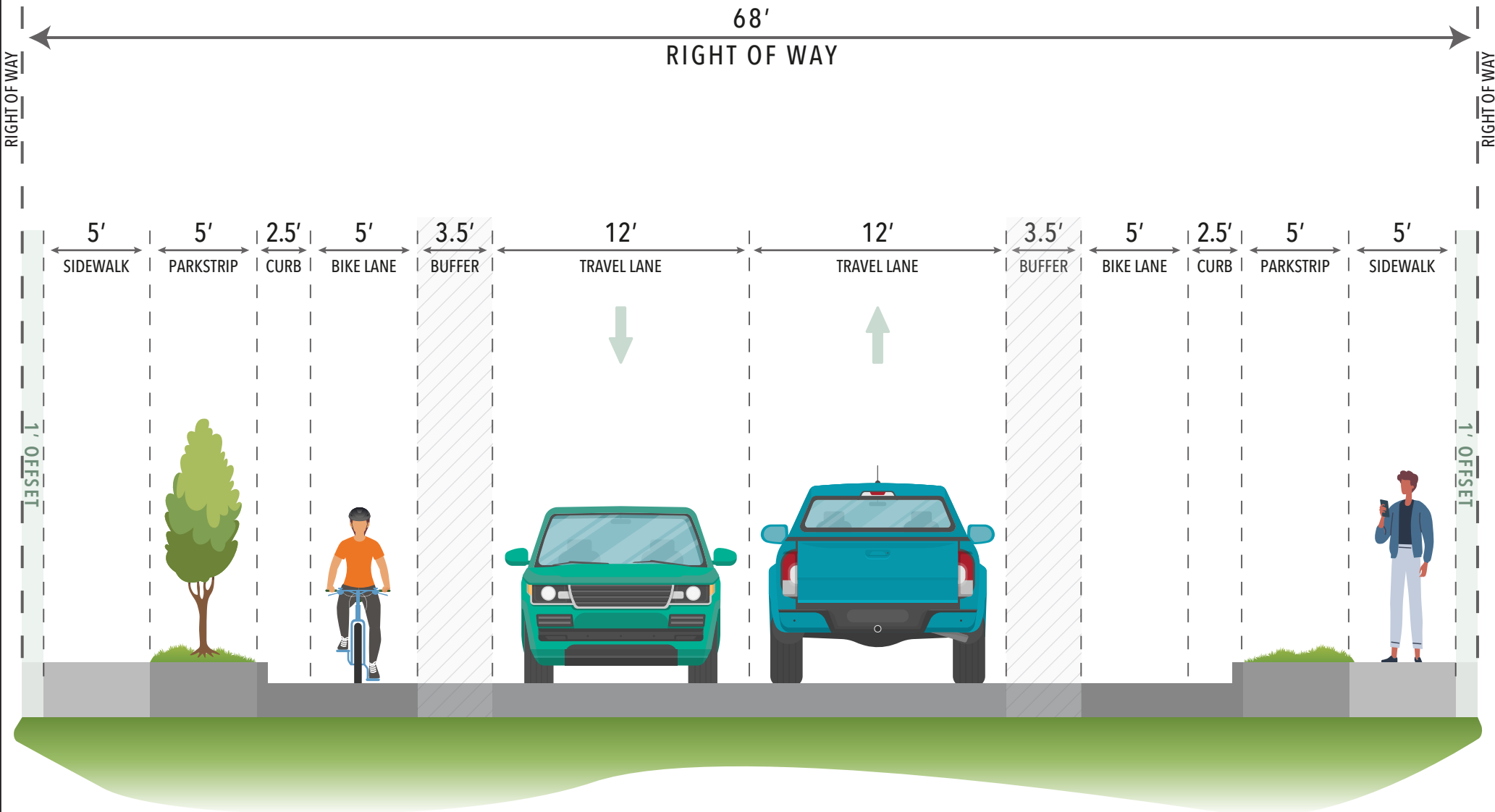

WOODS CROSS CITY - MINOR COLLECTOR

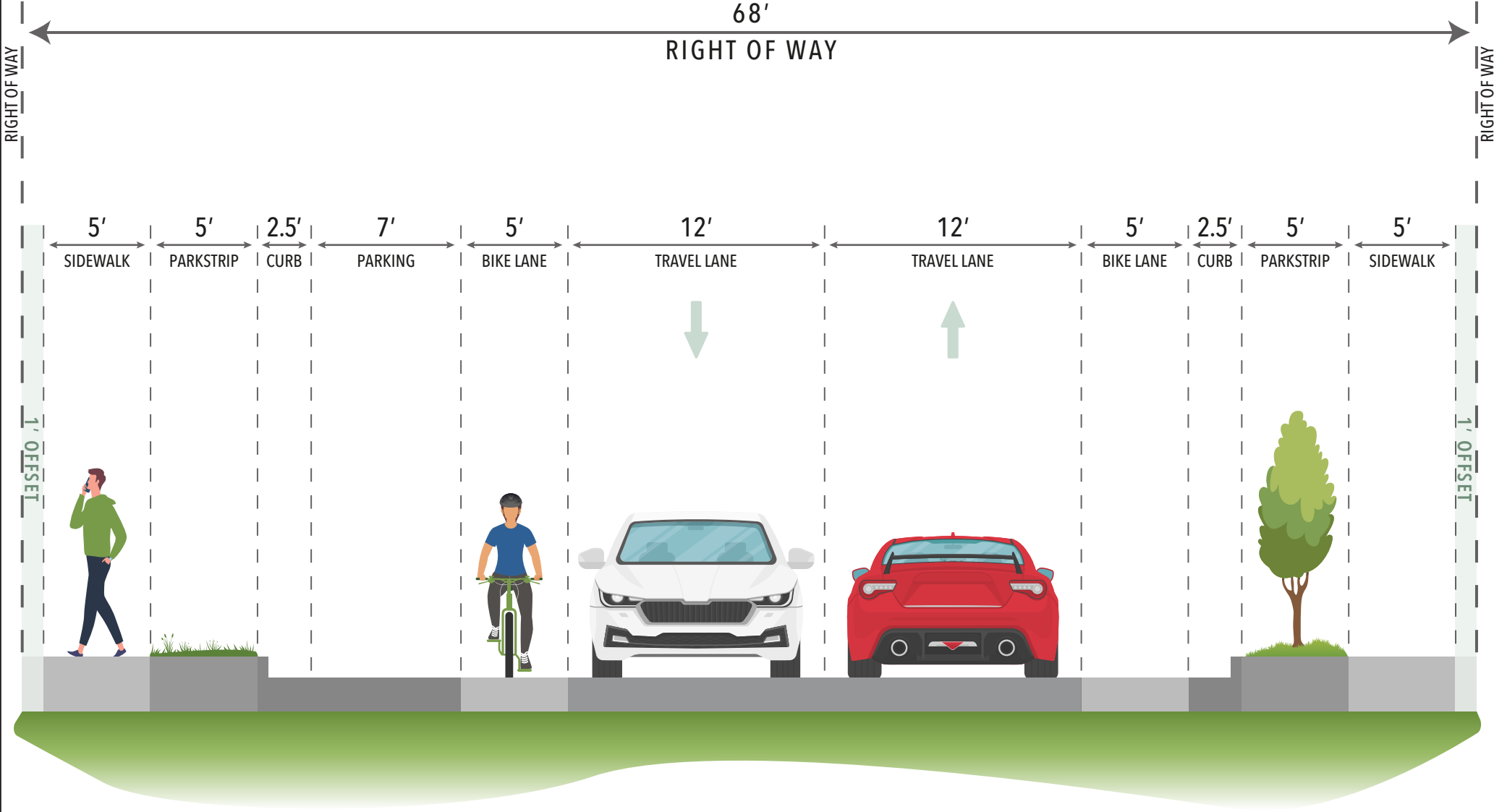

WOODS CROSS CITY - MAJOR COLLECTOR

(Share Use Path)

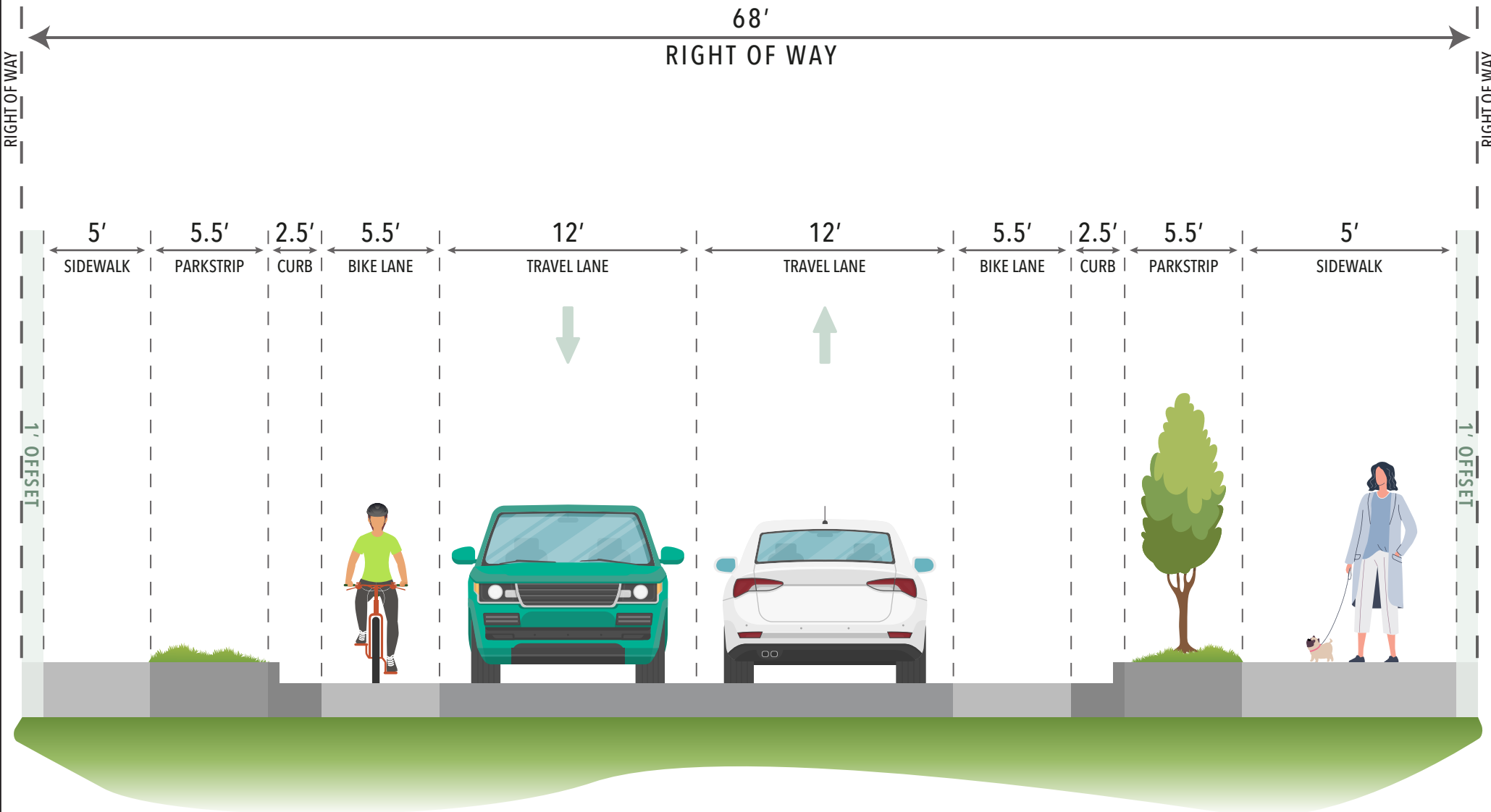

WOODS CROSS CITY - LOCAL

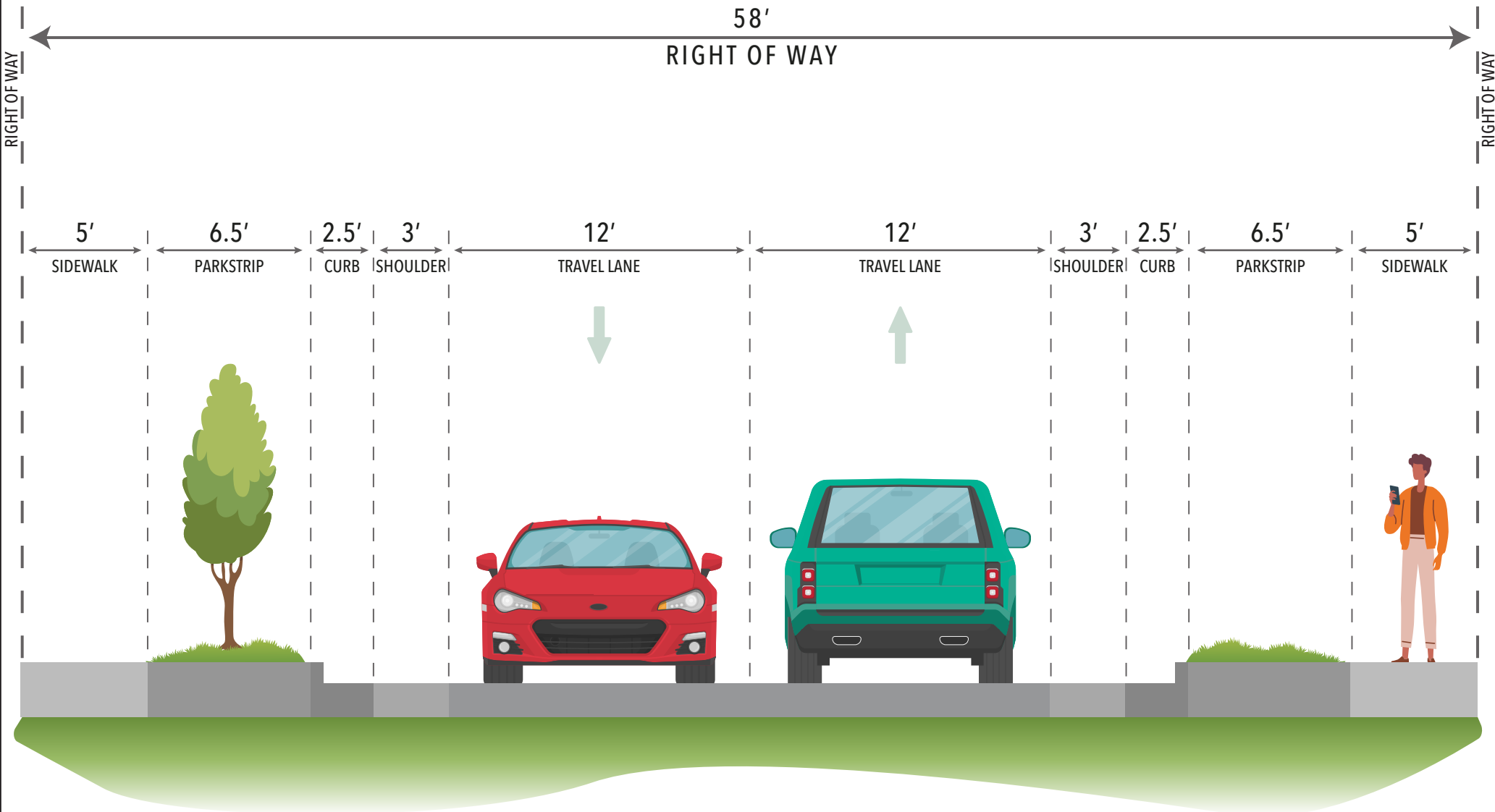

APPENDIX E: COMMUNITY ENGAGEMENT

DRAFT

Community Engagement

WOODS CROSS TRANSPORTATION MASTER PLAN

BACKGROUND

Woods Cross City is in the process of updating its Transportation Master Plan to reflect current community needs, local conditions, and long-term transportation goals. This effort is informed by the community's vision for a safe, efficient, and connected transportation system that serves all users from drivers, pedestrians, cyclists, and transit riders.

To help guide this planning process, Woods Cross City conducted early public engagement activities to gather community input on transportation priorities and values. This input was collected through an online comment mapping activity designed to identify transportation challenges and opportunities throughout the city and an in person open houses for comment gathering. These engagement activities were held both virtually and in person to ensure broad accessibility.

The online mapping was open from October 2024 to December 2024. Promotion of the comment mapping and engagement activities included city social media platforms, the Woods Cross City website, direct email notifications, and city newsletters.

This **Woods Cross City Transportation Master Plan – Community Engagement Summary Report** includes three key sections:

1. **Who We Heard From** – detailing participant demographics and outreach reach.

2. **What We Heard** – summarizing the key themes and community priorities that emerged.
3. **Appendices** – community comments and sign-in sheets.

Who We Heard From

A total of 13 online comments come through the online comment mapping. 41 documented in-person attendees went to the in-person open house that was held on November 20, 2024, and a total of seven comment cards were collected from that event. While demographic information was not collected for in-person participants or online participants, these events focused on reaching people who specifically lived in Woods Cross. Of the 41 documented attendees for the open house, 39 were Woods Cross residents, and two were from elsewhere. Of the online comments, ten comments were made by Woods Cross residents, and three were made anonymously.

What We Heard

This section summarizes community priorities for the city's transportation master plan and feedback on existing conditions.

Online and in-person participants were asked to express areas that they felt could be improved and their vision for how Woods Cross streets and transportation should feel and look in the future. Online comments are location specific and can be seen in appendix A & B. In-person comments can be seen in appendix D. The following key themes emerged as potential inspirations for the transportation master plan.

1. **Bicycle & Pedestrian:** Pedestrian and cyclist safety is a recurring concern, particularly near schools and high-traffic corridors. Maintenance and infrastructure upgrades (e.g., sidewalks, crossings, bike lanes) are needed to improve accessibility and safety.
 - Requests for safer crossings (e.g., hawk lights near schools/Hogan Park).

- Poor sidewalk conditions (dirt, weeds, thorns) and lack of sidewalks in some areas.
 - Suggestions for striping improvements (center/edge lines, bike lanes) on major roads (1500 South, 800 West).
1. **Traffic:** Traffic flow and road quality are critical. Intersection redesigns (e.g., signals), pavement repairs, and better traffic management could address these issues.
 - Complaints about confusing intersections (e.g., 2600 S between 1100 W–500 W) and requests for stoplights.
 - Poor road conditions (cracking, steep slopes) on 800 West.
 - Frustration with inefficient 4-way stops causing congestion.
 1. **Safety:** Need for pedestrian safety measures near schools, including infrastructure changes (bulb-outs) and visibility improvements.
 - High risk for pedestrians (especially children) at school crossings; requests for bulb-outs to improve visibility.
 - Visibility obstructions (power poles, mailboxes) near crosswalks.
 1. **Landscaping/Aesthetics:** Aesthetic upkeep and consistent landscaping standards (for public/private properties) are needed to enhance community appeal.
 - Complaints about unkempt public spaces (e.g., UTA field, overgrown weeds).
 - Unattractive city entrances and poor landscaping enforcement for businesses.
 - Awkward pavement repairs in neighborhoods (e.g., Cloverdale entrance).
 1. **Transit:** Transit gaps (lack of routes) and rail-crossing hazards highlight the need for expanded service and infrastructure (e.g., overpasses).
 - Need for a direct bus route to downtown.

- Safety concerns due to blocked roads when trains stop on tracks; requests for an overpass.

Appendices

Appendix A: Comment Map



Appendix B: Online Comments

Comment Category	Comment
Traffic	Need a stoplight. Multiple travel lanes in east/west directions that doesn't work as a 4-way stop. Have to force your way through going North/South as east/west drivers constantly act like it is their turn.

Traffic	I avoid 2600 from 1100 W to 500 W at all costs. There are always too many cars and too much confusion.
Transit	There is no way west when long trains come through and especially when they stop on the tracks. There needs to be a way for us to safely leave the area, especially if there is an emergency. We cannot all go north to 400 N. It would be chaos and unsafe. We need an overpass.
Landscaping/Aesthetics	The entrance to the Cloverdale neighborhood had a broken sign and dead plants forever. We're thankful that it was taken out, but the pavement that was put in is awkward. It would be nice to have something beautiful there again or at least for the road to be smoothed out and even where the new pavement is.

Bicycle & Pedestrian	A hawk light here would make this crossing much safer for children coming and going from school and pedestrians using Hogan Park.
Landscaping/Aesthetics	This entrance to our city is unwelcoming, untidy, and ugly. Do city ordinances for landscaping and aesthetics apply to businesses as well? Additionally, the UTA field is often wild and only mowed down a few times in the summer. This brings weeds into neighborhoods and makes our city look uncared for.
Safety	I am writing to request a bulb-out at this intersection. It is quite dangerous with a large amount of children walking to school and crossing this street. I have spoken to several of the crossing guards both from this year and last and they all report daily near-misses for car accidents and car-pedestrian accidents. We are hoping a bulb out may be the solution to make this a safer walkway for our children as well as others.

Bicycle & Pedestrian	Much of the sidewalk along 1500 South is poorly maintained (dirt on the sidewalk and goat heads thorns growing onto the sidewalk). Would love to see wider sidewalks along 1500 South that would be more inviting to pedestrians along this major collector. The area that I have the most concern with is from 1100 West to the I-15.
Traffic	The pavement along 800 West from 1500 South to 2600 South could use a full depth reconstruction. The pavement is in bad shape (cracking and settled trenches) and has steep cross slopes.
Safety	During non-school crossing guard hours there is a poor visibility of pedestrians waiting to cross on the west side of this cross walk. A power pole and brick mailbox make it difficult to see pedestrians.
Bicycle & Pedestrian	Would love to see striping improvements along 1500 South and 800 West

Appendix D: Comment Cards

COMMENT CARD

**WOODS CROSS
TRANSPORTATION MASTER PLAN
OPEN HOUSE**



Name _____
Address _____ City _____ Zip _____
Email _____ Phone _____

Comments It would be very beneficial to have a
sidewalk on 1250 West from 2600 So to the
Legacy Schools. Kids walking to 2600 So do not have
a safe path to get there. Need a sidewalk on the
west side to the corner.

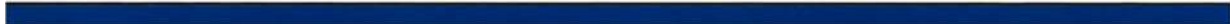

COMMENT CARD

**WOODS CROSS
TRANSPORTATION MASTER PLAN
OPEN HOUSE**



Name _____
Address _____ City _____ Zip _____
Email _____ Phone _____

Comments IDEAS FOR BETTER ACCOMMODATING TRAFFIC FROM
NORTHBOUND 700 W TO WESTBOUND 500 S?

COMMENT CARD

**WOODS CROSS
TRANSPORTATION MASTER PLAN
OPEN HOUSE**



Name _____
Address _____ City _____ Zip _____
Email _____ Phone _____

Comments Need crossing on 1500 So.
There is only one on 1450 W, Redwood Rd & 1100 W.

COMMENT CARD

WOODS CROSS TRANSPORTATION MASTER PLAN OPEN HOUSE



Name _____
Address _____ City _____ Zip _____
Email _____ Phone _____

Comments
Bikelanes for the community is a big safety issue to address.
Bike lanes are getting more & more in our area and drivers need to be educated around bikers with appropriate ~~to~~ bike lanes, etc.



WELCOME

TRANSPORTATION MASTER PLAN OPEN HOUSE



PURPOSE

- Connectivity
- Reducing congestion
- Increasing safety
- Supporting growth
- Planning for the city infrastructure and network
- Plan and promote active transportation



TIMELINE

PHASE AND TASK		2024				2025													
		Aug	Sept	Oct	Nov	Dec	Jan	Feb	Mar	Apr	May	June	July	Aug	Sept	Oct	Nov	Dec	
1	Project Initiation and Data collection	Active																	
2	Assessment and Analysis					Active													
3	Plan Refinement and Finalization										Active								
4	Project Closeout													Active					

PROCESS

1

- Kick-off Project
- Review of data
- Public engagement
- Initial data collection
- Collect and analyze data
- Field visits
- Draft goals and objectives

2

- Conduct traffic analysis
- Assess infrastructure
- Identify deficiencies
- Evaluate transportation options and forecast
- Analyze trends
- Assess environmental and social impacts
- Gather public feedback
- Incorporate public input
- Develop transportation alternatives
- Evaluate alternatives
- Analyze cost-effectiveness
- Develop recommendations and identify potential projects

3

- Present draft plans
- gather feedback
- refine implementation
- present plans for adoption.
- Finalize planning reports and deliver plans

4

- Prepare final report
- Deliver final report and archive data
- Closeout

TRAFFIC AND SAFETY

Improvements

- Road Capacity Upgrades
- Intersection modifications
- Active transportation plan
- Traffic calming measures
- Public transit



PUBLIC INVOLVEMENT

- Identifies Community Needs and Priorities
 - Local Knowledge: Residents often have valuable insights about travel patterns, dangerous intersections, or gaps in accessibility.
 - Priority alignment: Public input helps prioritize improvements that align with what matters most to the community.
- Plan Quality and Effectiveness
 - Diverse Perspectives: Public input often reveals the diverse ways people use and experience transportation.

PUBLIC INVOLVEMENT

- Increases Safety and Usability
 - Identifies Safety: Residents can identify areas where they feel unsafe, leading to safety-focused adjustments that benefit the community.
 - Accessibility Improvements: Feedback from a range of users, including elderly individuals, people with disabilities, and parents with young children, can lead to a more accessible transportation network for everyone.
- Building Trust
 - Open Communication: The city values resident input and is committed to addressing their needs.

HOW TO STAY INVOLVED

- Follow Woods Cross socials
- Leave comments online or through comment card
- Look out for City Newsletters
- Email project team
 - WoodCrossTMP@TLGInfo.com



PLEASE SIGN IN

WOODS CROSS TRANSPORTATION MASTER PLAN OPEN HOUSE

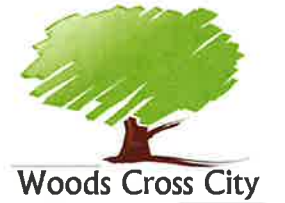

NAME	ADDRESS	EMAIL	PHONE
Anne Blankenship	1918 S. 580 W ⁿ , WX	amblankenship@prodigy.net	801-589-9676 cell 801-554 801-292-1695 home
Hall Blankenship	1918 S 580w WX	hblankenship@prodigy.net	Home 801 292-1695 Cell 801 554-2651
Kaylene & Tony Titcomb	220 W. 1100 S WX	tonyandkaylene@gmail.com	801 243 7915 801 940 1111
MARK & JULIE ADAMSON	780 W. 2250 S. WX	markadamson@juno.com	801-530-9416
Daylene Riley	1613 Sorrento Dr	rilymcb@msn.com	801-643-8962
Todd Riley	1613 Sorrento DR	hathqny9100@gmail.com	801-643-8693
Trina McConkie	730 W 2125 S WX	trina.mcconkie@gmail.com	801-292-9745

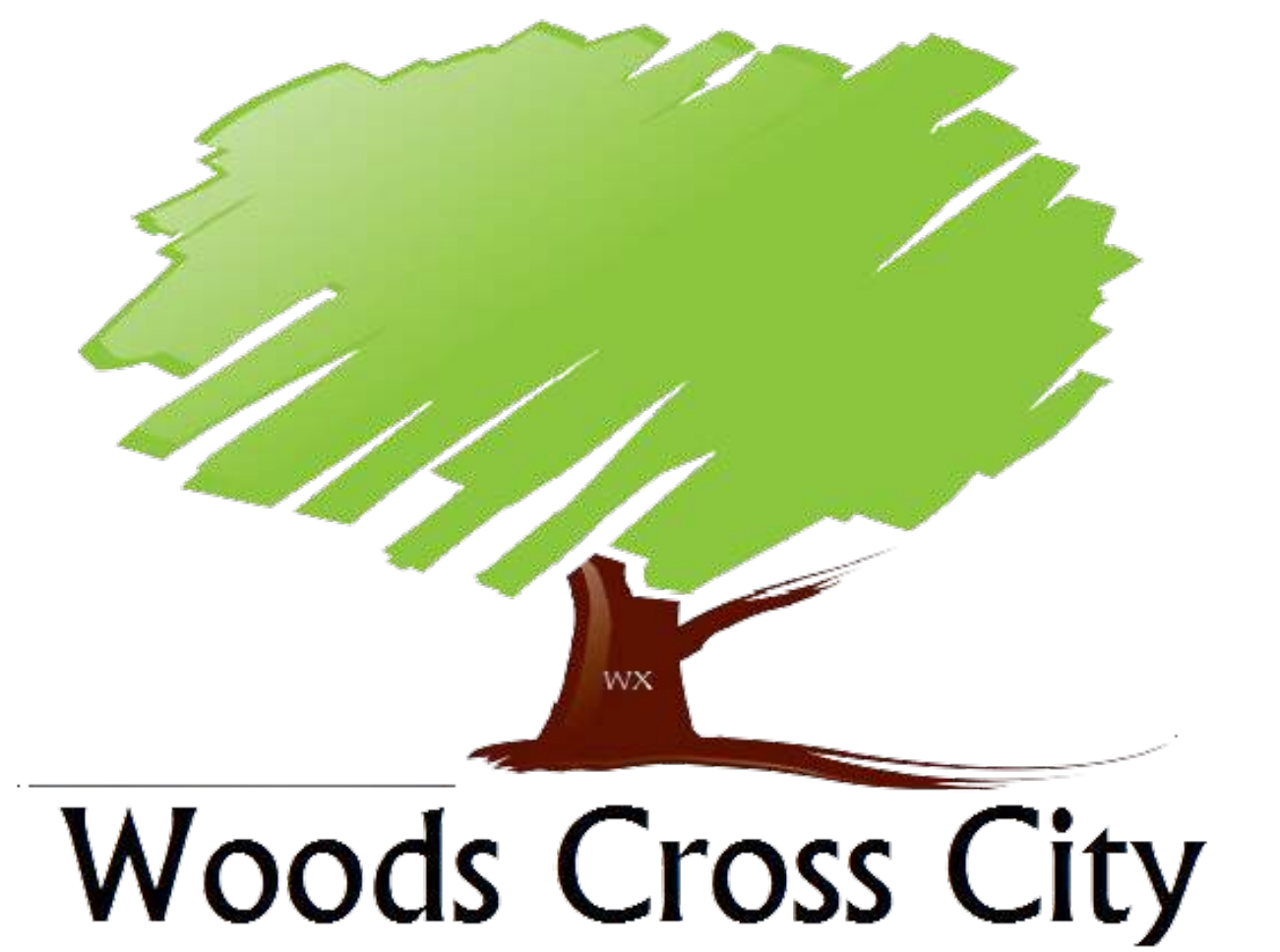

WELCOME

TRANSPORTATION MASTER PLAN OPEN HOUSE



January 21, 2026

Existing Road Classifications

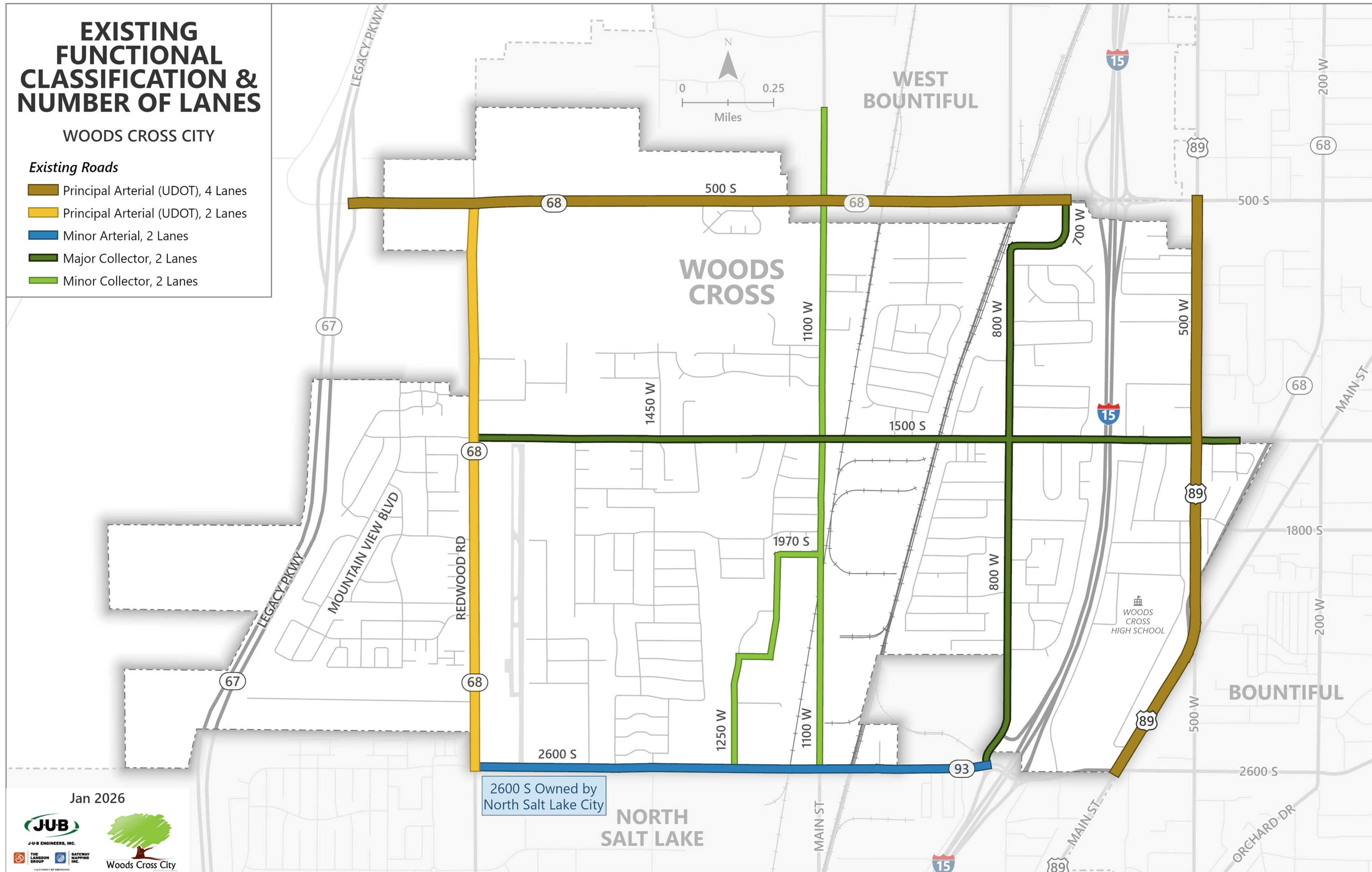

Annual Average Daily Traffic

EXISTING AVERAGE ANNUAL DAILY TRAFFIC & LEVEL OF SERVICE

WOODS CROSS CITY

Colored numbers indicate AADT volume

- Existing Roads
- █ LOS A, B, C
 - █ LOS D
 - █ LOS E, F

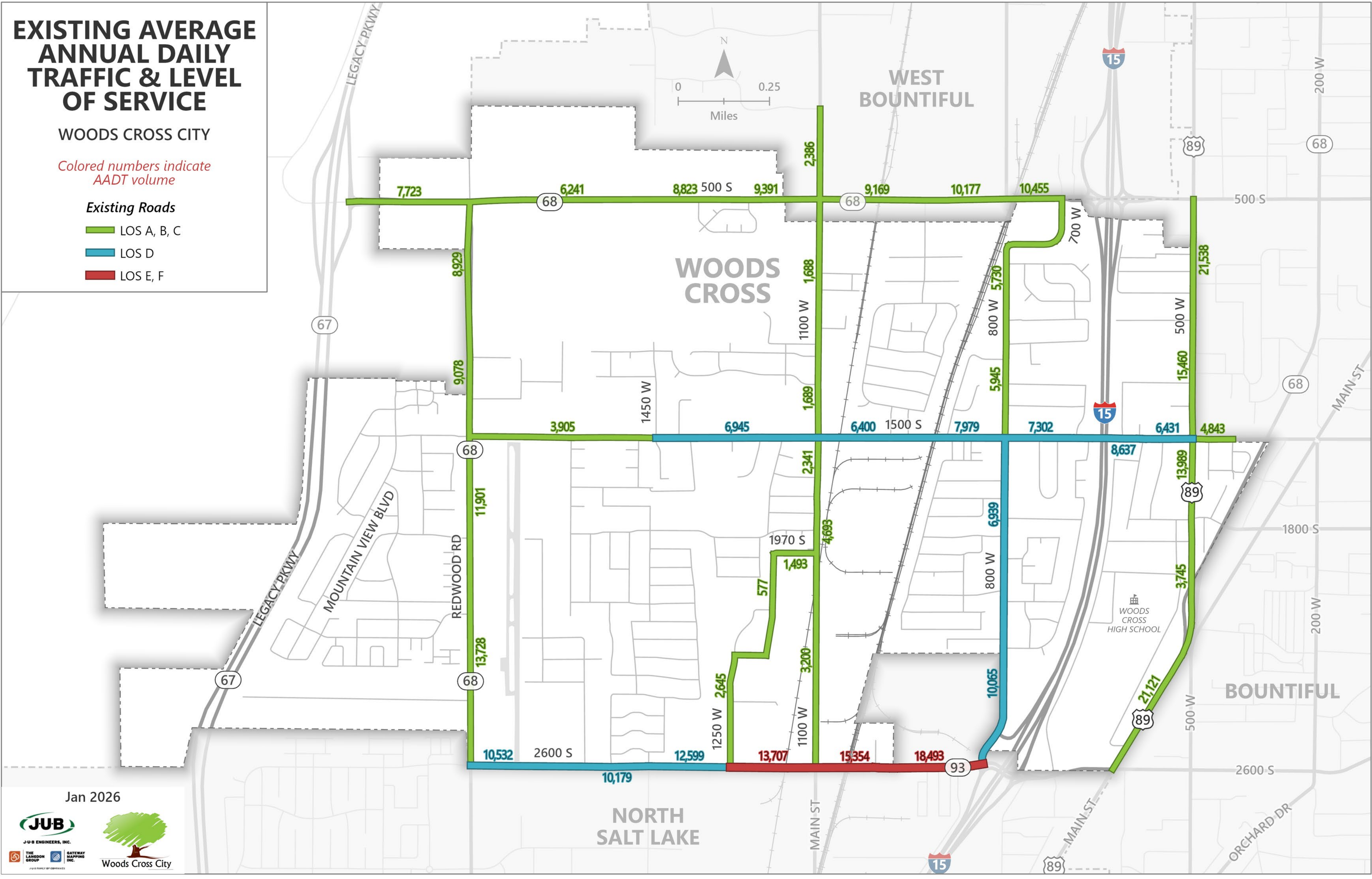

Jan 2026



2050 Build Functional Classifications

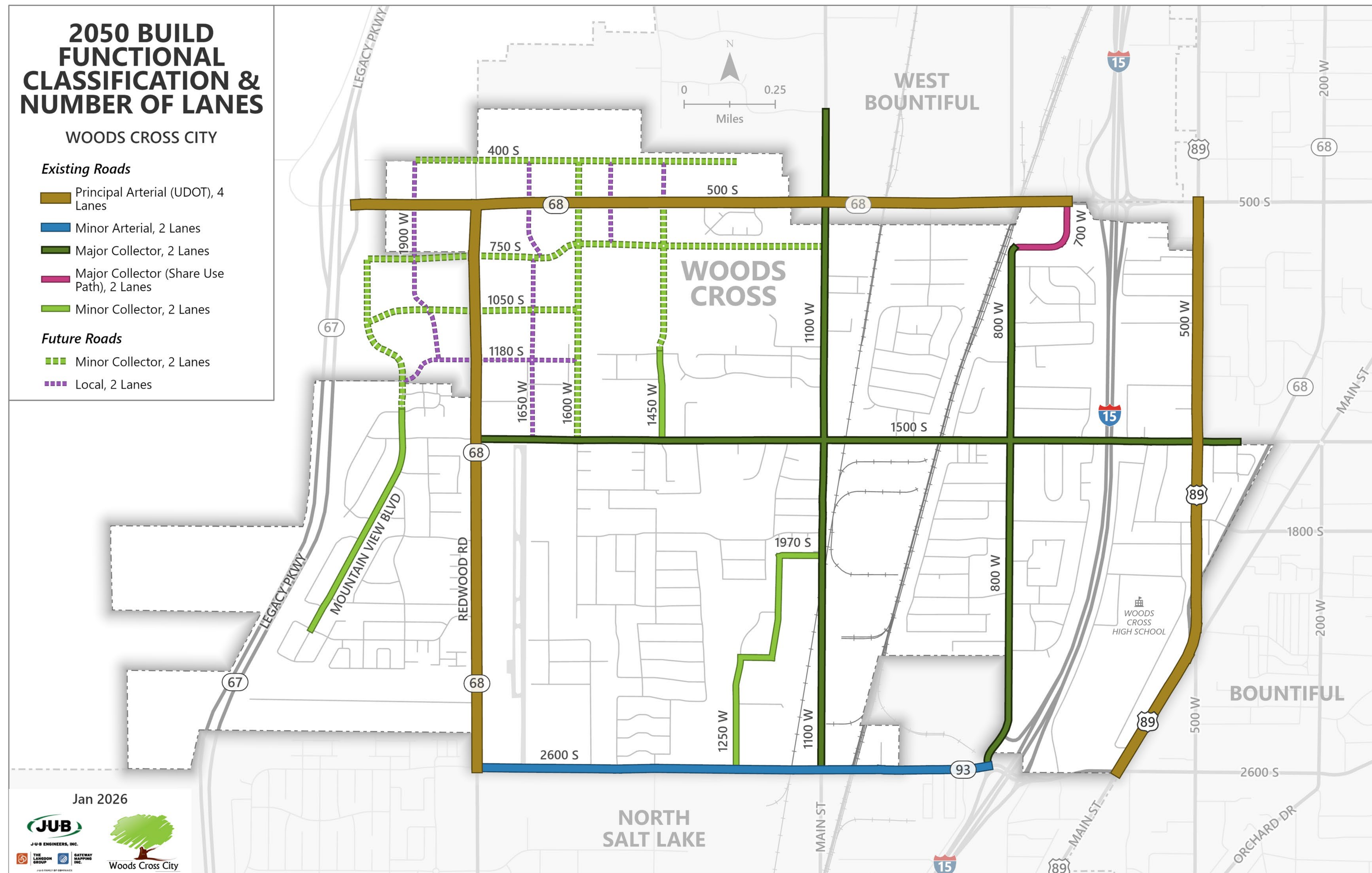

Senate Bill - 195 Projects

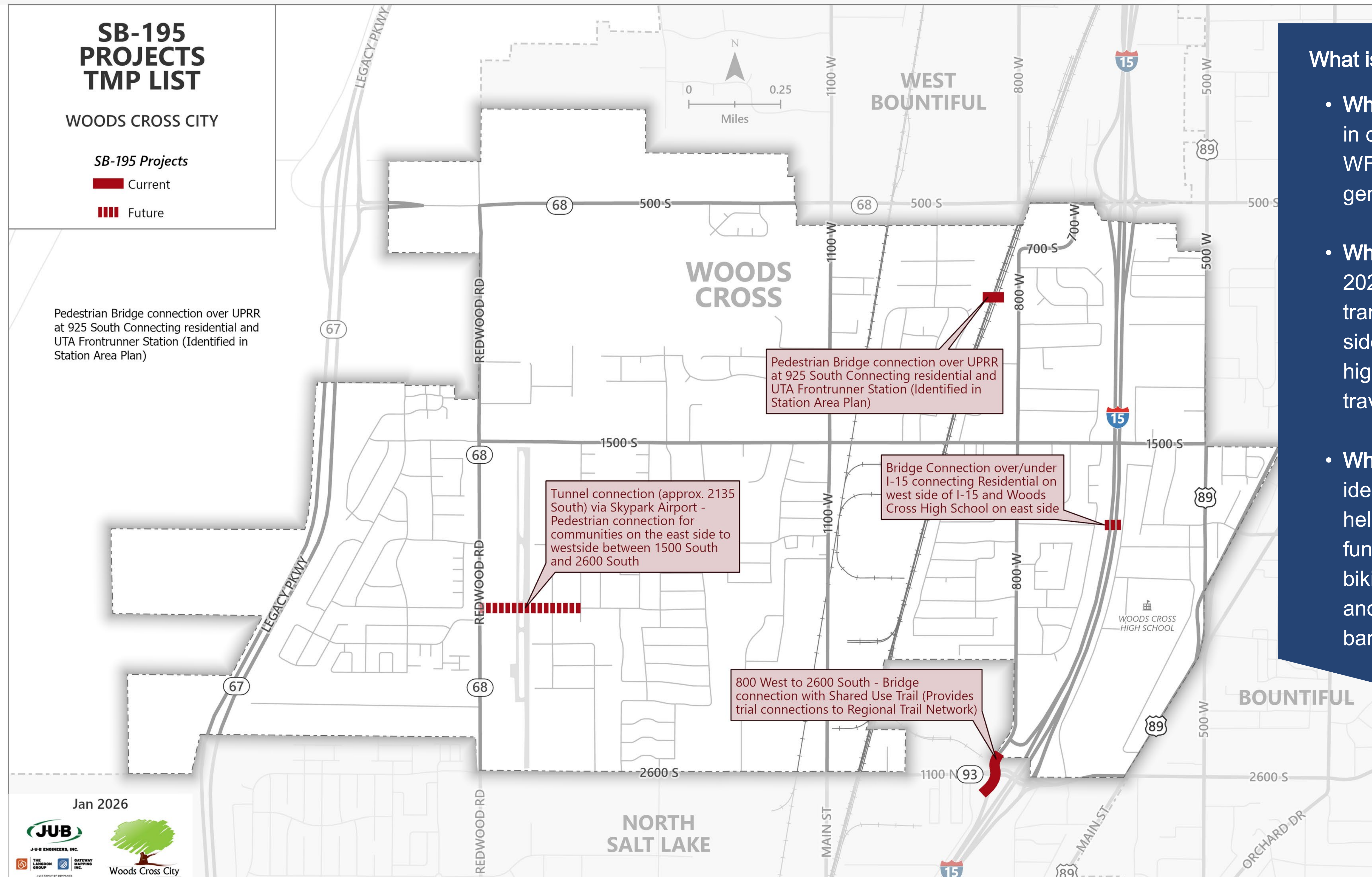















What is SB - 195 & Why It Matters

- **What it is:** A new rule that cities in certain metro areas (like WFRC) must update their general plans.
- **What it requires :** By July 1, 2027, cities must revise their transportation plans (streets, sidewalks, bike paths, transit) to highlight the most important travel routes.
- **Why it matters:** These identified “priority connections” help guide which projects get funding, especially for walking, biking, and transit, from UDOT and regional infrastructure banks.

Active Transportation Plan

ACTIVE TRANSPORTATION MASTER PLAN

WOODS CROSS CITY

-  Pedestrian Bridge
-  Trailhead
- Trails**
-  Existing Trail
-  Future Trail
-  Existing Bikeway
-  Future Bikeway
-  Existing Sidewalk Connector
-  Future Sidewalk Connector
-  School
-  Intersection Improvements
- Crash Severity**
-  Fatal (1)
-  Suspected Minor Injury (3)
-  Possible Injury; Possible Minor Injury (14)
-  No Injury (5)

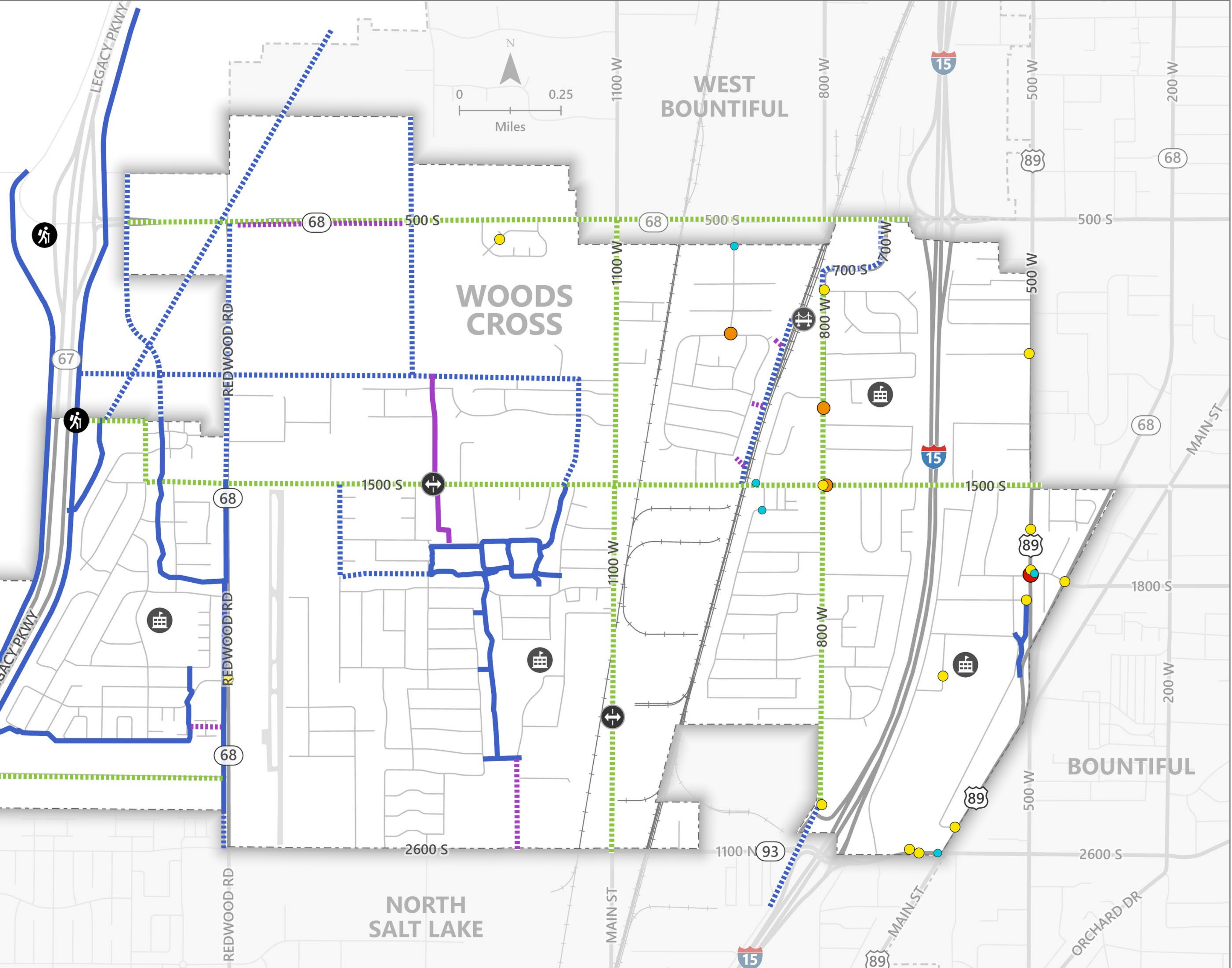

Jan 2026





HOW TO STAY INVOLVED

- Follow Woods Cross socials
- Watch for City Newsletters
- Email project team
 - WoodCrossTMP@TLGInfo.com

APPENDIX F: PROJECT COST ESTIMATES

DRAFT

 ENGINEER'S OPINION OF PROBABLE COST					
PROJECT NAME:				DATE: 2/4/2026	
Woods Cross TMP					
PROJECT DESCRIPTION:					
Roadway Cost					
CLIENT:					
City of Woods Cross					
J-U-B PROJ. NO.: 07-24-094					
No.	ITEM	QUANTITY	UNIT	UNIT COST	TOTAL COST
1250 W - 1780 Feet					
1950 S to 2275 S					
1	Mobilization - 10%	1	LS	\$282,068.51	\$282,068.51
2	Storm Water Pollution Prevention	1	LS	\$17,800.00	\$17,800.00
3	Traffic Control - 10%	1	LS	\$282,068.51	\$282,068.51
4	Clear and Grub	1	LS	\$14,240.00	\$14,240.00
5	Dust Control & Watering	1	LS	\$6,230.00	\$6,230.00
6	Survey - 3%	1	LS	\$84,620.55	\$84,620.55
7	Drainage Pipes and System	1	LS	\$427,200.00	\$427,200.00
8	Relocate Street Light	7	EA	\$1,500.00	\$10,500.00
9	Roadway Excavation (Plan Quantity)	44,577	CY	\$25.00	\$1,114,422.84
10	Remove Asphalt Pavement	8,307	SY	\$6.50	\$53,993.33
11	Relocate Sign	13	EA	\$200.00	\$2,600.00
12	Concrete Curb and Gutter	8,900	LF	\$28.00	\$249,200.00
13	HMA 6"	2,700	TON	\$150.00	\$405,039.00
14	Untreated Based Course 10"	3,077	CY	\$32.00	\$98,449.38
15	Granular Sub Base 12"	3,033	CY	\$28.00	\$84,912.59
16	Concrete Driveway	1,500	SF	\$20.00	\$30,000.00
17	Concrete Sidewalk	17,800	SF	\$15.00	\$267,000.00
18	Concrete Curb Ramp	4	EA	\$3,500.00	\$14,000.00
19	4" Paint Line	7,120	LF	\$1.00	\$7,120.00
20	Sod	21,360	SF	\$1.30	\$27,768.00
21	Topsoil-6 inch thick	2,373	SY	\$12.00	\$28,480.00
				SUBTOTAL	\$3,507,712.73
				ROW Acquisition	\$0.00
				Contingency - 35%	\$1,227,699.46
				Design Engineering - 10%	\$350,771.27
				Construction Engineering - 10%	\$350,771.27
				Miscellaneous Item - 5%	\$175,385.64
				Total:	\$5,612,400.00

 ENGINEER'S OPINION OF PROBABLE COST					
PROJECT NAME:					DATE:
Woods Cross TMP					2/4/2026
PROJECT DESCRIPTION:					
Roadway Cost					
CLIENT:					
City of Woods Cross					
J-U-B PROJ. NO.: 07-24-094					
No.	ITEM	QUANTITY	UNIT	UNIT COST	TOTAL COST
1250 W - 1590 Feet					
2275 S to 2600 S					
22	Mobilization - 10%	1	LS	\$251,179.57	\$251,179.57
23	Storm Water Pollution Prevention	1	LS	\$15,900.00	\$15,900.00
24	Traffic Control - 10%	1	LS	\$251,179.57	\$251,179.57
25	Clear and Grub	1	LS	\$12,720.00	\$12,720.00
26	Dust Control & Watering	1	LS	\$5,565.00	\$5,565.00
27	Survey - 3%	1	LS	\$75,353.87	\$75,353.87
28	Drainage Pipes and System	1	LS	\$381,600.00	\$381,600.00
29	Roadway Excavation (Plan Quantity)	39,819	CY	\$25.00	\$995,467.59
30	Remove Asphalt Pavement	7,420	SY	\$6.50	\$48,230.00
31	Relocate Sign	6	EA	\$200.00	\$1,200.00
32	Concrete Curb and Gutter	7,950	LF	\$28.00	\$222,600.00
33	HMA 6"	2,412	TON	\$150.00	\$361,804.50
34	Untreated Based Course 10"	2,748	CY	\$32.00	\$87,940.74
35	Granular Sub Base 12"	2,709	CY	\$28.00	\$75,848.89
36	Concrete Driveway	1,750	SF	\$20.00	\$35,000.00
37	Concrete Sidewalk	15,900	SF	\$15.00	\$238,500.00
38	Concrete Curb Ramp	2	EA	\$3,500.00	\$7,000.00
39	4" Paint Line	6,360	LF	\$1.00	\$6,360.00
40	Sod	19,080	SF	\$1.30	\$24,804.00
41	Topsoil-6 inch thick	2,120	SY	\$12.00	\$25,440.00
				SUBTOTAL	\$3,123,693.74
				ROW Acquisition	\$0.00
				Contingency - 35%	\$1,093,292.81
				Design Engineering - 10%	\$312,369.37
				Construction Engineering - 10%	\$312,369.37
				Miscellaneous Item - 5%	\$156,184.69
Total:					\$4,998,000.00

 ENGINEER'S OPINION OF PROBABLE COST					
PROJECT NAME: Woods Cross TMP		DATE: 2/4/2026			
PROJECT DESCRIPTION: Roadway Cost					
CLIENT: City of Woods Cross					
J-U-B PROJ. NO.: 07-24-094					
No.	ITEM	QUANTITY	UNIT	UNIT COST	TOTAL COST
1100 W - 1780 Feet					
50 S to 500 S					
1	Mobilization - 10%	1	LS	\$292,958.33	\$292,958.33
2	Storm Water Pollution Prevention	1	LS	\$17,800.00	\$17,800.00
3	Traffic Control - 10%	1	LS	\$292,958.33	\$292,958.33
4	Clear and Grub	1	LS	\$14,240.00	\$14,240.00
5	Dust Control & Watering	1	LS	\$6,230.00	\$6,230.00
6	Survey - 3%	1	LS	\$87,887.50	\$87,887.50
7	Utilities (Contingency)	1	LS	\$146,479.16	\$146,479.16
8	Drainage Pipes and System	1	LS	\$427,200.00	\$427,200.00
9	Relocate Street Light	7	EA	\$1,500.00	\$10,500.00
10	Roadway Excavation (Plan Quantity)	47,610	CY	\$25.00	\$1,190,237.65
11	Remove Asphalt Pavement	6,329	SY	\$6.50	\$41,137.78
12	Relocate Sign	1	EA	\$200.00	\$200.00
13	Concrete Curb and Gutter	8,900	LF	\$28.00	\$249,200.00
14	HMA 6"	2,898	TON	\$150.00	\$434,676.00
15	Untreated Based Course 10"	3,241	CY	\$32.00	\$103,723.46
16	Granular Sub Base 12"	3,230	CY	\$28.00	\$90,450.37
17	Concrete Driveway	1,500	SF	\$20.00	\$30,000.00
18	Concrete Sidewalk	17,800	SF	\$15.00	\$267,000.00
19	Concrete Curb Ramp	6	EA	\$3,500.00	\$21,000.00
20	4" Paint Line	8,010	LF	\$1.00	\$8,010.00
21	Sod	21,360	SF	\$1.30	\$27,768.00
22	Topsoil-6 inch thick	2,373	SY	\$12.00	\$28,480.00
				SUBTOTAL	\$3,788,136.57
				ROW Acquisition	\$0.00
				Contingency - 35%	\$1,325,847.80
				Design Engineering - 10%	\$378,813.66
				Construction Engineering - 10%	\$378,813.66
				Miscellaneous Item - 5%	\$189,406.83
				Total:	\$6,061,100.00

 ENGINEER'S OPINION OF PROBABLE COST						
PROJECT NAME:					DATE:	2/4/2026
Woods Cross TMP						
PROJECT DESCRIPTION:						
Roadway Cost						
CLIENT:						
City of Woods Cross						
J-U-B PROJ. NO.: 07-24-094						
No.	ITEM	QUANTITY	UNIT	UNIT COST	TOTAL COST	
1100 W - 790 Feet						
500 S to 750 S						
23	Mobilization - 10%	1	LS	\$131,108.35	\$131,108.35	
24	Storm Water Pollution Prevention	1	LS	\$7,900.00	\$7,900.00	
25	Traffic Control - 10%	1	LS	\$131,108.35	\$131,108.35	
26	Clear and Grub	1	LS	\$6,320.00	\$6,320.00	
27	Dust Control & Watering	1	LS	\$2,765.00	\$2,765.00	
28	Survey - 3%	1	LS	\$39,332.50	\$39,332.50	
29	Drainage Pipes and System	1	LS	\$189,600.00	\$189,600.00	
30	Roadway Excavation (Plan Quantity)	21,130	CY	\$25.00	\$528,251.54	
31	Remove Asphalt Pavement	2,633	SY	\$6.50	\$17,116.67	
32	Relocate Sign	2	EA	\$200.00	\$400.00	
33	Concrete Curb and Gutter	3,950	LF	\$28.00	\$110,600.00	
34	HMA 6"	1,286	TON	\$150.00	\$192,918.00	
35	Untreated Based Course 10"	1,439	CY	\$32.00	\$46,034.57	
36	Granular Sub Base 12"	1,434	CY	\$28.00	\$40,143.70	
37	Concrete Driveway	1,250	SF	\$20.00	\$25,000.00	
38	Concrete Sidewalk	7,900	SF	\$15.00	\$118,500.00	
39	Concrete Curb Ramp	4	EA	\$3,500.00	\$14,000.00	
40	4" Paint Line	3,555	LF	\$1.00	\$3,555.00	
41	Sod	9,480	SF	\$1.30	\$12,324.00	
42	Topsoil-6 inch thick	1,053	SY	\$12.00	\$12,640.00	
				SUBTOTAL	\$1,629,617.68	
				ROW Acquisition	\$0.00	
				Contingency - 35%	\$570,366.19	
				Design Engineering - 10%	\$162,961.77	
				Construction Engineering - 10%	\$162,961.77	
				Miscellaneous Item - 5%	\$81,480.88	
Total:					\$2,607,400.00	

ENGINEER'S OPINION OF PROBABLE COST					
					
J-U-B ENGINEERS, INC.					
PROJECT NAME: Woods Cross TMP				DATE: 2/4/2026	
PROJECT DESCRIPTION: Roadway Cost					
CLIENT: City of Woods Cross					
J-U-B PROJ. NO.: 07-24-094					
No.	ITEM	QUANTITY	UNIT	UNIT COST	TOTAL COST
1100 W - 1360 Feet					
750 S to 1125 S					
43	Mobilization - 10%	1	LS	\$219,748.73	\$219,748.73
44	Storm Water Pollution Prevention	1	LS	\$13,600.00	\$13,600.00
45	Traffic Control - 10%	1	LS	\$219,748.73	\$219,748.73
46	Clear and Grub	1	LS	\$10,880.00	\$10,880.00
47	Dust Control & Watering	1	LS	\$4,760.00	\$4,760.00
48	Survey - 3%	1	LS	\$65,924.62	\$65,924.62
49	Drainage Pipes and System	1	LS	\$326,400.00	\$326,400.00
50	Relocate Street Light	1	EA	\$1,500.00	\$1,500.00
51	Roadway Excavation (Plan Quantity)	36,376	CY	\$25.00	\$909,395.06
52	Remove Asphalt Pavement	3,173	SY	\$6.50	\$20,626.67
53	Relocate Sign	3	EA	\$200.00	\$600.00
54	Concrete Curb and Gutter	6,800	LF	\$28.00	\$190,400.00
55	HMA 6"	2,214	TON	\$150.00	\$332,112.00
56	Untreated Based Course 10"	2,477	CY	\$32.00	\$79,249.38
57	Granular Sub Base 12"	2,468	CY	\$28.00	\$69,108.15
58	Concrete Driveway	750	SF	\$20.00	\$15,000.00
59	Concrete Sidewalk	13,600	SF	\$15.00	\$204,000.00
60	4" Paint Line	6,120	LF	\$1.00	\$6,120.00
61	Sod	16,320	SF	\$1.30	\$21,216.00
62	Topsoil-6 inch thick	1,813	SY	\$12.00	\$21,760.00
				SUBTOTAL	\$2,732,149.33
				ROW Acquisition	\$0.00
				Contingency - 35%	\$956,252.27
				Design Engineering - 10%	\$273,214.93
				Construction Engineering - 10%	\$273,214.93
				Miscellaneous Item - 5%	\$136,607.47
				Total:	\$4,371,500.00

ENGINEER'S OPINION OF PROBABLE COST					
					
J-U-B ENGINEERS, INC.					
PROJECT NAME: Woods Cross TMP				DATE: 2/4/2026	
PROJECT DESCRIPTION: Roadway Cost					
CLIENT: City of Woods Cross					
J-U-B PROJ. NO.: 07-24-094					
No.	ITEM	QUANTITY	UNIT	UNIT COST	TOTAL COST
1100 W - 1360 Feet					
1125 S to 1500 S					
63	Mobilization - 10%	1	LS	\$233,844.95	\$233,844.95
64	Storm Water Pollution Prevention	1	LS	\$13,600.00	\$13,600.00
65	Traffic Control - 10%	1	LS	\$233,844.95	\$233,844.95
66	Clear and Grub	1	LS	\$10,880.00	\$10,880.00
67	Dust Control & Watering	1	LS	\$4,760.00	\$4,760.00
68	Survey - 3%	1	LS	\$70,153.48	\$70,153.48
69	Utilities (Contingency)	1	LS	\$116,922.47	\$116,922.47
70	Drainage Pipes and System	1	LS	\$326,400.00	\$326,400.00
71	Relocate Street Light	4	EA	\$1,500.00	\$6,000.00
72	Roadway Excavation (Plan Quantity)	36,376	CY	\$25.00	\$909,395.06
73	Remove Asphalt Pavement	6,044	SY	\$6.50	\$39,288.89
74	Relocate Sign	7	EA	\$200.00	\$1,400.00
75	Concrete Curb and Gutter	6,800	LF	\$28.00	\$190,400.00
76	HMA 6"	2,214	TON	\$150.00	\$332,112.00
77	Untreated Based Course 10"	2,477	CY	\$32.00	\$79,249.38
78	Granular Sub Base 12"	2,468	CY	\$28.00	\$69,108.15
79	Concrete Driveway	6,250	SF	\$20.00	\$125,000.00
80	Concrete Sidewalk	13,600	SF	\$15.00	\$204,000.00
81	Concrete Curb Ramp	2	EA	\$3,500.00	\$7,000.00
82	4" Paint Line	6,120	LF	\$1.00	\$6,120.00
83	Sod	16,320	SF	\$1.30	\$21,216.00
84	Topsoil-6 inch thick	1,813	SY	\$12.00	\$21,760.00
				SUBTOTAL	\$3,022,455.34
				ROW Acquisition	\$0.00
				Contingency - 35%	\$1,057,859.37
				Design Engineering - 10%	\$302,245.53
				Construction Engineering - 10%	\$302,245.53
				Miscellaneous Item - 5%	\$151,122.77
				Total:	\$4,836,000.00

 ENGINEER'S OPINION OF PROBABLE COST						
PROJECT NAME:					DATE:	2/4/2026
Woods Cross TMP						
PROJECT DESCRIPTION:						
Roadway Cost						
CLIENT:						
City of Woods Cross						
J-U-B PROJ. NO.: 07-24-094						
No.	ITEM	QUANTITY	UNIT	UNIT COST	TOTAL COST	
1100 W - 1060 Feet						
1500 S to 1850 S						
85	Mobilization - 10%	1	LS	\$181,552.73	\$181,552.73	
86	Storm Water Pollution Prevention	1	LS	\$10,600.00	\$10,600.00	
87	Traffic Control - 10%	1	LS	\$181,552.73	\$181,552.73	
88	Clear and Grub	1	LS	\$8,480.00	\$8,480.00	
89	Dust Control & Watering	1	LS	\$3,710.00	\$3,710.00	
90	Survey - 3%	1	LS	\$54,465.82	\$54,465.82	
91	Utilities (Contingency)	1	LS	\$90,776.36	\$90,776.36	
92	Drainage Pipes and System	1	LS	\$254,400.00	\$254,400.00	
93	Relocate Street Light	2	EA	\$1,500.00	\$3,000.00	
94	Roadway Excavation (Plan Quantity)	28,352	CY	\$25.00	\$708,793.21	
95	Remove Asphalt Pavement	5,182	SY	\$6.50	\$33,684.44	
96	Relocate Sign	5	EA	\$200.00	\$1,000.00	
97	Concrete Curb and Gutter	5,300	LF	\$28.00	\$148,400.00	
98	HMA 6"	1,726	TON	\$150.00	\$258,852.00	
99	Untreated Based Course 10"	1,930	CY	\$32.00	\$61,767.90	
100	Granular Sub Base 12"	1,924	CY	\$28.00	\$53,863.70	
101	Concrete Driveway	3,500	SF	\$20.00	\$70,000.00	
102	Concrete Sidewalk	10,600	SF	\$15.00	\$159,000.00	
103	Concrete Curb Ramp	7	EA	\$3,500.00	\$24,500.00	
104	4" Paint Line	4,770	LF	\$1.00	\$4,770.00	
105	Sod	12,720	SF	\$1.30	\$16,536.00	
106	Topsoil-6 inch thick	1,413	SY	\$12.00	\$16,960.00	
SUBTOTAL					\$2,346,664.89	
ROW Acquisition					\$0.00	
Contingency - 35%					\$821,332.71	
Design Engineering - 10%					\$234,666.49	
Construction Engineering - 10%					\$234,666.49	
Miscellaneous Item - 5%					\$117,333.24	
Total:					\$3,754,700.00	

ENGINEER'S OPINION OF PROBABLE COST					
					
J-U-B ENGINEERS, INC.					
PROJECT NAME: Woods Cross TMP				DATE: 2/4/2026	
PROJECT DESCRIPTION: Roadway Cost					
CLIENT: City of Woods Cross					
J-U-B PROJ. NO.: 07-24-094					
No.	ITEM	QUANTITY	UNIT	UNIT COST	TOTAL COST
1100 W - 520 Feet					
1850 S to 1970 S					
107	Mobilization - 10%	1	LS	\$85,971.53	\$85,971.53
108	Storm Water Pollution Prevention	1	LS	\$5,200.00	\$5,200.00
109	Traffic Control - 10%	1	LS	\$85,971.53	\$85,971.53
110	Clear and Grub	1	LS	\$4,160.00	\$4,160.00
111	Dust Control & Watering	1	LS	\$1,820.00	\$1,820.00
112	Survey - 3%	1	LS	\$25,791.46	\$25,791.46
113	Utilities (Contingency)	1	LS	\$42,985.76	\$42,985.76
114	Drainage Pipes and System	1	LS	\$124,800.00	\$124,800.00
115	Relocate Street Light	1	EA	\$1,500.00	\$1,500.00
116	Roadway Excavation (Plan Quantity)	13,908	CY	\$25.00	\$347,709.88
117	Remove Asphalt Pavement	2,542	SY	\$6.50	\$16,524.44
118	Relocate Sign	2	EA	\$200.00	\$400.00
119	Concrete Curb and Gutter	2,600	LF	\$28.00	\$72,800.00
120	HMA 6"	847	TON	\$150.00	\$126,984.00
121	Untreated Based Course 10"	947	CY	\$32.00	\$30,301.23
122	Granular Sub Base 12"	944	CY	\$28.00	\$26,423.70
123	Concrete Driveway	250	SF	\$20.00	\$5,000.00
124	Concrete Sidewalk	5,200	SF	\$15.00	\$78,000.00
125	Concrete Curb Ramp	3	EA	\$3,500.00	\$10,500.00
126	4" Paint Line	2,340	LF	\$1.00	\$2,340.00
127	Sod	6,240	SF	\$1.30	\$8,112.00
128	Topsoil-6 inch thick	693	SY	\$12.00	\$8,320.00
				SUBTOTAL	\$1,111,615.53
				ROW Acquisition	\$0.00
				Contingency - 35%	\$389,065.44
				Design Engineering - 10%	\$111,161.55
				Construction Engineering - 10%	\$111,161.55
				Miscellaneous Item - 5%	\$55,580.78
				Total:	\$1,778,600.00

ENGINEER'S OPINION OF PROBABLE COST					
					
J-U-B ENGINEERS, INC.					
PROJECT NAME: Woods Cross TMP				DATE: 2/4/2026	
PROJECT DESCRIPTION: Roadway Cost					
CLIENT: City of Woods Cross					
J-U-B PROJ. NO.: 07-24-094					
No.	ITEM	QUANTITY	UNIT	UNIT COST	TOTAL COST
1100 W - 3040 Feet					
1970 S to 2600 S					
129	Mobilization - 10%	1	LS	\$493,816.68	\$493,816.68
130	Storm Water Pollution Prevention	1	LS	\$30,400.00	\$30,400.00
131	Traffic Control - 10%	1	LS	\$493,816.68	\$493,816.68
132	Clear and Grub	1	LS	\$24,320.00	\$24,320.00
133	Dust Control & Watering	1	LS	\$10,640.00	\$10,640.00
134	Survey - 3%	1	LS	\$148,145.00	\$148,145.00
135	Utilities (Contingency)	1	LS	\$246,908.34	\$246,908.34
136	Drainage Pipes and System	1	LS	\$729,600.00	\$729,600.00
137	Relocate Street Light	4	EA	\$1,500.00	\$6,000.00
138	Roadway Excavation (Plan Quantity)	81,311	CY	\$25.00	\$2,032,765.43
139	Remove Asphalt Pavement	10,133	SY	\$6.50	\$65,866.67
140	Relocate Sign	8	EA	\$200.00	\$1,600.00
141	Concrete Curb and Gutter	15,200	LF	\$28.00	\$425,600.00
142	HMA 6"	4,949	TON	\$150.00	\$742,368.00
143	Untreated Based Course 10"	5,536	CY	\$32.00	\$177,145.68
144	Granular Sub Base 12"	5,517	CY	\$28.00	\$154,477.04
145	Concrete Driveway	1,500	SF	\$20.00	\$30,000.00
146	Concrete Sidewalk	30,400	SF	\$15.00	\$456,000.00
147	Concrete Curb Ramp	2	EA	\$3,500.00	\$7,000.00
148	4" Paint Line	13,680	LF	\$1.00	\$13,680.00
149	Sod	36,480	SF	\$1.30	\$47,424.00
150	Topsoil-6 inch thick	4,053	SY	\$12.00	\$48,640.00
				SUBTOTAL	\$6,386,213.52
				ROW Acquisition	\$0.00
				Contingency - 35%	\$2,235,174.73
				Design Engineering - 10%	\$638,621.35
				Construction Engineering - 10%	\$638,621.35
				Miscellaneous Item - 5%	\$319,310.68
Total:					\$10,218,000.00



J-U-B ENGINEERS, INC.

ENGINEER'S OPINION OF PROBABLE COST

PROJECT NAME: Woods Cross TMP **DATE:** 2/4/2026

PROJECT DESCRIPTION: Roadway Cost

CLIENT: City of Woods Cross

J-U-B PROJ. NO.: 07-24-094

No.	ITEM	QUANTITY	UNIT	UNIT COST	TOTAL COST
700 W - 580 Feet					
500 S to 700 S					
1	Mobilization - 10%	1	LS	\$86,706.22	\$86,706.22
2	Storm Water Pollution Prevention	1	LS	\$5,800.00	\$5,800.00
3	Traffic Control - 10%	1	LS	\$86,706.22	\$86,706.22
4	Clear and Grub	1	LS	\$4,640.00	\$4,640.00
5	Dust Control & Watering	1	LS	\$2,030.00	\$2,030.00
6	Survey - 3%	1	LS	\$26,011.87	\$26,011.87
7	Utilities (Contingency)	1	LS	\$43,353.11	\$43,353.11
8	Drainage Pipes and System	1	LS	\$139,200.00	\$139,200.00
9	Relocate Street Light	3	EA	\$1,500.00	\$4,500.00
10	Roadway Excavation (Plan Quantity)	12,602	CY	\$25.00	\$315,061.73
11	Remove Asphalt Pavement	2,964	SY	\$6.50	\$19,268.89
12	Relocate Sign	5	EA	\$200.00	\$1,000.00
13	Concrete Curb and Gutter	2,900	LF	\$28.00	\$81,200.00
14	HMA 6"	751	TON	\$150.00	\$112,665.00
15	Untreated Based Course 10"	895	CY	\$32.00	\$28,641.98
16	Granular Sub Base 12"	859	CY	\$28.00	\$24,059.26
17	Concrete Driveway	1,250	SF	\$20.00	\$25,000.00
18	Concrete Sidewalk	5,800	SF	\$15.00	\$87,000.00
19	Concrete Curb Ramp	2	EA	\$3,500.00	\$7,000.00
20	4" Paint Line	2,610	LF	\$1.00	\$2,610.00
21	Sod	7,540	SF	\$1.30	\$9,802.00
22	Topsoil-6 inch thick	838	SY	\$12.00	\$10,053.33
				SUBTOTAL	\$1,122,309.60
				ROW Acquisition	\$0.00
				Contingency - 35%	\$392,808.36
				Design Engineering - 10%	\$112,230.96
				Construction Engineering - 10%	\$112,230.96
				Miscellaneous Item - 5%	\$56,115.48
Total:					\$1,795,700.00

 ENGINEER'S OPINION OF PROBABLE COST					
PROJECT NAME: Woods Cross TMP					DATE: 2/4/2026
PROJECT DESCRIPTION: Roadway Cost					
CLIENT: City of Woods Cross					
J-U-B PROJ. NO.: 07-24-094					
No.	ITEM	QUANTITY	UNIT	UNIT COST	TOTAL COST
700 S - 650 Feet					
700 W to 800 W					
1	Mobilization - 10%	1	LS	\$94,918.73	\$94,918.73
2	Storm Water Pollution Prevention	1	LS	\$6,500.00	\$6,500.00
3	Traffic Control - 10%	1	LS	\$94,918.73	\$94,918.73
4	Clear and Grub	1	LS	\$5,200.00	\$5,200.00
5	Dust Control & Watering	1	LS	\$2,275.00	\$2,275.00
6	Survey - 3%	1	LS	\$28,475.62	\$28,475.62
7	Drainage Pipes and System	1	LS	\$156,000.00	\$156,000.00
8	Relocate Street Light	6	EA	\$1,500.00	\$9,000.00
9	Roadway Excavation (Plan Quantity)	14,123	CY	\$25.00	\$353,086.42
10	Remove Asphalt Pavement	2,600	SY	\$6.50	\$16,900.00
11	Relocate Sign	1	EA	\$200.00	\$200.00
12	Concrete Curb and Gutter	3,250	LF	\$28.00	\$91,000.00
13	HMA 6"	842	TON	\$150.00	\$126,262.50
14	Untreated Based Course 10"	1,003	CY	\$32.00	\$32,098.77
15	Granular Sub Base 12"	963	CY	\$28.00	\$26,962.96
16	Concrete Driveway	750	SF	\$20.00	\$15,000.00
17	Concrete Sidewalk	6,500	SF	\$15.00	\$97,500.00
18	4" Paint Line	2,925	LF	\$1.00	\$2,925.00
19	Sod	8,450	SF	\$1.30	\$10,985.00
20	Topsoil-6 inch thick	939	SY	\$12.00	\$11,266.67
				SUBTOTAL	\$1,181,475.40
				ROW Acquisition	\$0.00
				Contingency - 35%	\$413,516.39
				Design Engineering - 10%	\$118,147.54
				Construction Engineering - 10%	\$118,147.54
				Miscellaneous Item - 5%	\$59,073.77
Total:					\$1,890,400.00



J-U-B ENGINEERS, INC.

ENGINEER'S OPINION OF PROBABLE COST

PROJECT NAME:

DATE: 2/4/2026

Woods Cross TMP

PROJECT DESCRIPTION:

Roadway Cost

CLIENT:

City of Woods Cross

J-U-B PROJ. NO.: 07-24-094

No.	ITEM	QUANTITY	UNIT	UNIT COST	TOTAL COST
800 W - 1080 Feet					
700 S to 1000 S					
1	Mobilization - 10%	1	LS	\$182,202.40	\$182,202.40
2	Storm Water Pollution Prevention	1	LS	\$10,800.00	\$10,800.00
3	Traffic Control - 10%	1	LS	\$182,202.40	\$182,202.40
4	Clear and Grub	1	LS	\$8,640.00	\$8,640.00
5	Dust Control & Watering	1	LS	\$3,780.00	\$3,780.00
6	Survey - 3%	1	LS	\$54,660.72	\$54,660.72
7	Utilities (Contingency)	1	LS	\$91,101.20	\$91,101.20
8	Drainage Pipes and System	1	LS	\$259,200.00	\$259,200.00
9	Relocate Street Light	1	EA	\$1,500.00	\$1,500.00
10	Roadway Excavation (Plan Quantity)	28,887	CY	\$25.00	\$722,166.67
11	Remove Asphalt Pavement	5,280	SY	\$6.50	\$34,320.00
12	Relocate Sign	8	EA	\$200.00	\$1,600.00
13	Concrete Curb and Gutter	5,400	LF	\$28.00	\$151,200.00
14	HMA 6"	1,758	TON	\$150.00	\$263,736.00
15	Untreated Based Course 10"	1,967	CY	\$32.00	\$62,933.33
16	Granular Sub Base 12"	1,960	CY	\$28.00	\$54,880.00
17	Concrete Driveway	2,250	SF	\$20.00	\$45,000.00
18	Concrete Sidewalk	10,800	SF	\$15.00	\$162,000.00
19	Concrete Curb Ramp	7	EA	\$3,500.00	\$24,500.00
20	4" Paint Line	4,860	LF	\$1.00	\$4,860.00
21	Sod	12,960	SF	\$1.30	\$16,848.00
22	Topsoil-6 inch thick	1,440	SY	\$12.00	\$17,280.00
				SUBTOTAL	\$2,355,410.72
				ROW Acquisition	\$0.00
				Contingency - 35%	\$824,393.75
				Design Engineering - 10%	\$235,541.07
				Construction Engineering - 10%	\$235,541.07
				Miscellaneous Item - 5%	\$117,770.54
Total:					\$3,768,700.00

 ENGINEER'S OPINION OF PROBABLE COST					
PROJECT NAME:					DATE:
Woods Cross TMP					2/4/2026
PROJECT DESCRIPTION:					
Roadway Cost					
CLIENT:					
City of Woods Cross					
J-U-B PROJ. NO.: 07-24-094					
No.	ITEM	QUANTITY	UNIT	UNIT COST	TOTAL COST
800 W - 1660 Feet					
1000 S to 1500 S					
23	Mobilization - 10%	1	LS	\$287,062.95	\$287,062.95
24	Storm Water Pollution Prevention	1	LS	\$16,600.00	\$16,600.00
25	Traffic Control - 10%	1	LS	\$287,062.95	\$287,062.95
26	Clear and Grub	1	LS	\$13,280.00	\$13,280.00
27	Dust Control & Watering	1	LS	\$5,810.00	\$5,810.00
28	Survey - 3%	1	LS	\$86,118.88	\$86,118.88
29	Drainage Pipes and System	1	LS	\$398,400.00	\$398,400.00
30	Relocate Street Light	6	EA	\$1,500.00	\$9,000.00
31	Roadway Excavation (Plan Quantity)	44,400	CY	\$25.00	\$1,109,996.91
32	Remove Asphalt Pavement	8,116	SY	\$6.50	\$52,751.11
33	Relocate Sign	21	EA	\$200.00	\$4,200.00
34	Concrete Curb and Gutter	8,300	LF	\$28.00	\$232,400.00
35	HMA 6"	2,702	TON	\$150.00	\$405,372.00
36	Untreated Based Course 10"	3,023	CY	\$32.00	\$96,730.86
37	Granular Sub Base 12"	3,013	CY	\$28.00	\$84,352.59
38	Concrete Driveway	6,500	SF	\$20.00	\$130,000.00
39	Concrete Sidewalk	16,600	SF	\$15.00	\$249,000.00
40	Concrete Curb Ramp	11	EA	\$3,500.00	\$38,500.00
41	4" Paint Line	7,470	LF	\$1.00	\$7,470.00
42	Sod	19,920	SF	\$1.30	\$25,896.00
43	Topsoil-6 inch thick	2,213	SY	\$12.00	\$26,560.00
				SUBTOTAL	\$3,566,564.26
				ROW Acquisition	\$0.00
				Contingency - 35%	\$1,248,297.49
				Design Engineering - 10%	\$356,656.43
				Construction Engineering - 10%	\$356,656.43
				Miscellaneous Item - 5%	\$178,328.21
Total:					\$5,706,600.00

 ENGINEER'S OPINION OF PROBABLE COST					
PROJECT NAME: Woods Cross TMP				DATE: 2/4/2026	
PROJECT DESCRIPTION: Roadway Cost					
CLIENT: City of Woods Cross					
J-U-B PROJ. NO.: 07-24-094					
No.	ITEM	QUANTITY	UNIT	UNIT COST	TOTAL COST
800 W - 2185 Feet					
1500 S to 2100 S					
44	Mobilization - 10%	1	LS	\$373,212.20	\$373,212.20
45	Storm Water Pollution Prevention	1	LS	\$21,850.00	\$21,850.00
46	Traffic Control - 10%	1	LS	\$373,212.20	\$373,212.20
47	Clear and Grub	1	LS	\$17,480.00	\$17,480.00
48	Dust Control & Watering	1	LS	\$7,647.50	\$7,647.50
49	Survey - 3%	1	LS	\$111,963.66	\$111,963.66
50	Drainage Pipes and System	1	LS	\$524,400.00	\$524,400.00
51	Relocate Street Light	9	EA	\$1,500.00	\$13,500.00
52	Roadway Excavation (Plan Quantity)	58,442	CY	\$25.00	\$1,461,050.15
53	Remove Asphalt Pavement	10,925	SY	\$6.50	\$71,012.50
54	Relocate Sign	11	EA	\$200.00	\$2,200.00
55	Concrete Curb and Gutter	10,925	LF	\$28.00	\$305,900.00
56	HMA 6"	3,557	TON	\$150.00	\$533,577.00
57	Untreated Based Course 10"	3,979	CY	\$32.00	\$127,323.46
58	Granular Sub Base 12"	3,965	CY	\$28.00	\$111,030.37
59	Concrete Driveway	6,500	SF	\$20.00	\$130,000.00
60	Concrete Sidewalk	21,850	SF	\$15.00	\$327,750.00
61	Concrete Curb Ramp	13	EA	\$3,500.00	\$45,500.00
62	4" Paint Line	9,833	LF	\$1.00	\$9,832.50
63	Sod	26,220	SF	\$1.30	\$34,086.00
64	Topsoil-6 inch thick	2,913	SY	\$12.00	\$34,960.00
				SUBTOTAL	\$4,637,487.54
				ROW Acquisition	\$0.00
				Contingency - 35%	\$1,623,120.64
				Design Engineering - 10%	\$463,748.75
				Construction Engineering - 10%	\$463,748.75
				Miscellaneous Item - 5%	\$231,874.38
				Total:	\$7,420,000.00



J-U-B ENGINEERS, INC.

ENGINEER'S OPINION OF PROBABLE COST

PROJECT NAME:

Woods Cross TMP

DATE: 2/4/2026

PROJECT DESCRIPTION:

Roadway Cost

CLIENT:

City of Woods Cross

J-U-B PROJ. NO.: 07-24-094

No.	ITEM	QUANTITY	UNIT	UNIT COST	TOTAL COST
800 W - 1700 Feet					
2100 S to 2400 S					
65	Mobilization - 10%	1	LS	\$291,879.52	\$291,879.52
66	Storm Water Pollution Prevention	1	LS	\$17,000.00	\$17,000.00
67	Traffic Control - 10%	1	LS	\$291,879.52	\$291,879.52
68	Clear and Grub	1	LS	\$13,600.00	\$13,600.00
69	Dust Control & Watering	1	LS	\$5,950.00	\$5,950.00
70	Survey - 3%	1	LS	\$87,563.86	\$87,563.86
71	Utilities (Contingency)	1	LS	\$145,939.76	\$145,939.76
72	Drainage Pipes and System	1	LS	\$408,000.00	\$408,000.00
73	Relocate Street Light	3	EA	\$1,500.00	\$4,500.00
74	Roadway Excavation (Plan Quantity)	45,470	CY	\$25.00	\$1,136,743.83
75	Remove Asphalt Pavement	8,122	SY	\$6.50	\$52,794.44
76	Relocate Sign	4	EA	\$200.00	\$800.00
77	Concrete Curb and Gutter	8,500	LF	\$28.00	\$238,000.00
78	HMA 6"	2,768	TON	\$150.00	\$415,140.00
79	Untreated Based Course 10"	3,096	CY	\$32.00	\$99,061.73
80	Granular Sub Base 12"	3,085	CY	\$28.00	\$86,385.19
81	Concrete Driveway	7,000	SF	\$20.00	\$140,000.00
82	Concrete Sidewalk	17,000	SF	\$15.00	\$255,000.00
83	Concrete Curb Ramp	6	EA	\$3,500.00	\$21,000.00
84	4" Paint Line	7,650	LF	\$1.00	\$7,650.00
85	Sod	20,400	SF	\$1.30	\$26,520.00
86	Topsoil-6 inch thick	2,267	SY	\$12.00	\$27,200.00
				SUBTOTAL	\$3,772,607.84
				ROW Acquisition	\$0.00
				Contingency - 35%	\$1,320,412.74
				Design Engineering - 10%	\$377,260.78
				Construction Engineering - 10%	\$377,260.78
				Miscellaneous Item - 5%	\$188,630.39
Total:					\$6,036,200.00



J-U-B ENGINEERS, INC.

ENGINEER'S OPINION OF PROBABLE COST

PROJECT NAME:

Woods Cross TMP

DATE: 2/4/2026

PROJECT DESCRIPTION:

Roadway Cost

CLIENT:

City of Woods Cross

J-U-B PROJ. NO.: 07-24-094

No.	ITEM	QUANTITY	UNIT	UNIT COST	TOTAL COST
800 W - 720 Feet					
2400 S to 2600 S					
87	Mobilization - 10%	1	LS	\$119,500.27	\$119,500.27
88	Storm Water Pollution Prevention	1	LS	\$7,200.00	\$7,200.00
89	Traffic Control - 10%	1	LS	\$119,500.27	\$119,500.27
90	Clear and Grub	1	LS	\$5,760.00	\$5,760.00
91	Dust Control & Watering	1	LS	\$2,520.00	\$2,520.00
92	Survey - 3%	1	LS	\$35,850.08	\$35,850.08
93	Utilities (Contingency)	1	LS	\$59,750.13	\$59,750.13
94	Drainage Pipes and System	1	LS	\$172,800.00	\$172,800.00
95	Relocate Street Light	4	EA	\$1,500.00	\$6,000.00
96	Roadway Excavation (Plan Quantity)	19,258	CY	\$25.00	\$481,444.44
97	Remove Asphalt Pavement	4,000	SY	\$6.50	\$26,000.00
98	Relocate Sign	3	EA	\$200.00	\$600.00
99	Concrete Curb and Gutter	3,600	LF	\$28.00	\$100,800.00
100	HMA 6"	1,172	TON	\$150.00	\$175,824.00
101	Untreated Based Course 10"	1,311	CY	\$32.00	\$41,955.56
102	Granular Sub Base 12"	1,307	CY	\$28.00	\$36,586.67
103	Concrete Driveway	250	SF	\$20.00	\$5,000.00
104	Concrete Sidewalk	7,200	SF	\$15.00	\$108,000.00
105	Concrete Curb Ramp	4	EA	\$3,500.00	\$14,000.00
106	4" Paint Line	3,240	LF	\$1.00	\$3,240.00
107	Sod	8,640	SF	\$1.30	\$11,232.00
108	Topsoil-6 inch thick	960	SY	\$12.00	\$11,520.00
				SUBTOTAL	\$1,545,083.41
				ROW Acquisition	\$0.00
				Contingency - 35%	\$540,779.19
				Design Engineering - 10%	\$154,508.34
				Construction Engineering - 10%	\$154,508.34
				Miscellaneous Item - 5%	\$77,254.17
Total:					\$2,472,200.00

 ENGINEER'S OPINION OF PROBABLE COST					
PROJECT NAME: Woods Cross TMP		DATE: 2/4/2026			
PROJECT DESCRIPTION: Roadway Cost					
CLIENT: City of Woods Cross					
J-U-B PROJ. NO.: 07-24-094					
No.	ITEM	QUANTITY	UNIT	UNIT COST	TOTAL COST
1500 S - 1280 Feet					
Redwood Rd to 1650 W					
1	Mobilization - 10%	1	LS	\$214,434.25	\$214,434.25
2	Storm Water Pollution Prevention	1	LS	\$12,800.00	\$12,800.00
3	Traffic Control - 10%	1	LS	\$214,434.25	\$214,434.25
4	Clear and Grub	1	LS	\$10,240.00	\$10,240.00
5	Dust Control & Watering	1	LS	\$4,480.00	\$4,480.00
6	Survey - 3%	1	LS	\$64,330.28	\$64,330.28
7	Drainage Pipes and System	1	LS	\$307,200.00	\$307,200.00
8	Relocate Street Light	2	EA	\$1,500.00	\$3,000.00
9	Roadway Excavation (Plan Quantity)	34,236	CY	\$25.00	\$855,901.23
10	Remove Asphalt Pavement	5,973	SY	\$6.50	\$38,826.67
11	Relocate Sign	4	EA	\$200.00	\$800.00
12	Concrete Curb and Gutter	6,400	LF	\$28.00	\$179,200.00
13	HMA 6"	2,084	TON	\$150.00	\$312,576.00
14	Untreated Based Course 10"	2,331	CY	\$32.00	\$74,587.65
15	Granular Sub Base 12"	2,323	CY	\$28.00	\$65,042.96
16	Concrete Driveway	2,750	SF	\$20.00	\$55,000.00
17	Concrete Sidewalk	12,800	SF	\$15.00	\$192,000.00
18	Concrete Curb Ramp	4	EA	\$3,500.00	\$14,000.00
19	4" Paint Line	5,760	LF	\$1.00	\$5,760.00
20	Sod	15,360	SF	\$1.30	\$19,968.00
21	Topsoil-6 inch thick	1,707	SY	\$12.00	\$20,480.00
				SUBTOTAL	\$2,665,061.30
				ROW Acquisition	\$0.00
				Contingency - 35%	\$932,771.45
				Design Engineering - 10%	\$266,506.13
				Construction Engineering - 10%	\$266,506.13
				Miscellaneous Item - 5%	\$133,253.06
				Total:	\$4,264,100.00

ENGINEER'S OPINION OF PROBABLE COST					
					
J-U-B ENGINEERS, INC.					
PROJECT NAME: Woods Cross TMP				DATE: 2/4/2026	
PROJECT DESCRIPTION: Roadway Cost					
CLIENT: City of Woods Cross					
J-U-B PROJ. NO.: 07-24-094					
No.	ITEM	QUANTITY	UNIT	UNIT COST	TOTAL COST
1500 S - 125 Feet					
1650 W to 1600 W					
22	Mobilization - 10%	1	LS	\$20,561.85	\$20,561.85
23	Storm Water Pollution Prevention	1	LS	\$1,250.00	\$1,250.00
24	Traffic Control - 10%	1	LS	\$20,561.85	\$20,561.85
25	Clear and Grub	1	LS	\$1,000.00	\$1,000.00
26	Dust Control & Watering	1	LS	\$437.50	\$437.50
27	Survey - 3%	1	LS	\$6,168.56	\$6,168.56
28	Drainage Pipes and System	1	LS	\$30,000.00	\$30,000.00
29	Roadway Excavation (Plan Quantity)	3,343	CY	\$25.00	\$83,584.10
30	Remove Asphalt Pavement	556	SY	\$6.50	\$3,611.11
31	Concrete Curb and Gutter	625	LF	\$28.00	\$17,500.00
32	HMA 6"	204	TON	\$150.00	\$30,525.00
33	Untreated Based Course 10"	228	CY	\$32.00	\$7,283.95
34	Granular Sub Base 12"	227	CY	\$28.00	\$6,351.85
35	Concrete Sidewalk	1,250	SF	\$15.00	\$18,750.00
36	Concrete Curb Ramp	1	EA	\$3,500.00	\$3,500.00
37	4" Paint Line	563	LF	\$1.00	\$562.50
38	Sod	1,500	SF	\$1.30	\$1,950.00
39	Topsoil-6 inch thick	167	SY	\$12.00	\$2,000.00
				SUBTOTAL	\$255,598.28
				ROW Acquisition	\$0.00
				Contingency - 35%	\$89,459.40
				Design Engineering - 10%	\$25,559.83
				Construction Engineering - 10%	\$25,559.83
				Miscellaneous Item - 5%	\$12,779.91
				Total:	\$409,000.00

 ENGINEER'S OPINION OF PROBABLE COST					
PROJECT NAME: Woods Cross TMP		DATE: 2/4/2026			
PROJECT DESCRIPTION: Roadway Cost					
CLIENT: City of Woods Cross					
J-U-B PROJ. NO.: 07-24-094					
No.	ITEM	QUANTITY	UNIT	UNIT COST	TOTAL COST
1500 S - 920 Feet					
1600 W to 1470 W					
40	Mobilization - 10%	1	LS	\$152,952.12	\$152,952.12
41	Storm Water Pollution Prevention	1	LS	\$9,200.00	\$9,200.00
42	Traffic Control - 10%	1	LS	\$152,952.12	\$152,952.12
43	Clear and Grub	1	LS	\$7,360.00	\$7,360.00
44	Dust Control & Watering	1	LS	\$3,220.00	\$3,220.00
45	Survey - 3%	1	LS	\$45,885.64	\$45,885.64
46	Drainage Pipes and System	1	LS	\$220,800.00	\$220,800.00
47	Relocate Street Light	2	EA	\$1,500.00	\$3,000.00
48	Roadway Excavation (Plan Quantity)	24,607	CY	\$25.00	\$615,179.01
49	Remove Asphalt Pavement	4,293	SY	\$6.50	\$27,906.67
50	Relocate Sign	3	EA	\$200.00	\$600.00
51	Concrete Curb and Gutter	4,600	LF	\$28.00	\$128,800.00
52	HMA 6"	1,498	TON	\$150.00	\$224,664.00
53	Untreated Based Course 10"	1,675	CY	\$32.00	\$53,609.88
54	Granular Sub Base 12"	1,670	CY	\$28.00	\$46,749.63
55	Concrete Driveway	1,500	SF	\$20.00	\$30,000.00
56	Concrete Sidewalk	9,200	SF	\$15.00	\$138,000.00
57	Concrete Curb Ramp	2	EA	\$3,500.00	\$7,000.00
58	4" Paint Line	4,140	LF	\$1.00	\$4,140.00
59	Sod	11,040	SF	\$1.30	\$14,352.00
60	Topsoil-6 inch thick	1,227	SY	\$12.00	\$14,720.00
				SUBTOTAL	\$1,901,091.06
				ROW Acquisition	\$0.00
				Contingency - 35%	\$665,381.87
				Design Engineering - 10%	\$190,109.11
				Construction Engineering - 10%	\$190,109.11
				Miscellaneous Item - 5%	\$95,054.55
				Total:	\$3,041,800.00

 ENGINEER'S OPINION OF PROBABLE COST					
PROJECT NAME: Woods Cross TMP		DATE: 2/4/2026			
PROJECT DESCRIPTION: Roadway Cost					
CLIENT: City of Woods Cross					
J-U-B PROJ. NO.: 07-24-094					
No.	ITEM	QUANTITY	UNIT	UNIT COST	TOTAL COST
1500 S - 200 Feet					
1470 W to 1450 W					
61	Mobilization - 10%	1	LS	\$34,248.96	\$34,248.96
62	Storm Water Pollution Prevention	1	LS	\$2,000.00	\$2,000.00
63	Traffic Control - 10%	1	LS	\$34,248.96	\$34,248.96
64	Clear and Grub	1	LS	\$1,600.00	\$1,600.00
65	Dust Control & Watering	1	LS	\$700.00	\$700.00
66	Survey - 3%	1	LS	\$10,274.69	\$10,274.69
67	Utilities (Contingency)	1	LS	\$17,124.48	\$17,124.48
68	Drainage Pipes and System	1	LS	\$48,000.00	\$48,000.00
69	Relocate Street Light	2	EA	\$1,500.00	\$3,000.00
70	Roadway Excavation (Plan Quantity)	5,349	CY	\$25.00	\$133,734.57
71	Remove Asphalt Pavement	889	SY	\$6.50	\$5,777.78
72	Relocate Sign	3	EA	\$200.00	\$600.00
73	Concrete Curb and Gutter	1,000	LF	\$28.00	\$28,000.00
74	HMA 6"	326	TON	\$150.00	\$48,840.00
75	Untreated Based Course 10"	364	CY	\$32.00	\$11,654.32
76	Granular Sub Base 12"	363	CY	\$28.00	\$10,162.96
77	Concrete Driveway	250	SF	\$20.00	\$5,000.00
78	Concrete Sidewalk	2,000	SF	\$15.00	\$30,000.00
79	Concrete Curb Ramp	3	EA	\$3,500.00	\$10,500.00
80	4" Paint Line	900	LF	\$1.00	\$900.00
81	Sod	2,400	SF	\$1.30	\$3,120.00
82	Topsoil-6 inch thick	267	SY	\$12.00	\$3,200.00
				SUBTOTAL	\$442,686.73
				ROW Acquisition	\$0.00
				Contingency - 35%	\$154,940.35
				Design Engineering - 10%	\$44,268.67
				Construction Engineering - 10%	\$44,268.67
				Miscellaneous Item - 5%	\$22,134.34
				Total:	\$708,300.00

 ENGINEER'S OPINION OF PROBABLE COST					
PROJECT NAME: Woods Cross TMP		DATE: 2/4/2026			
PROJECT DESCRIPTION: Roadway Cost					
CLIENT: City of Woods Cross					
J-U-B PROJ. NO.: 07-24-094					
No.	ITEM	QUANTITY	UNIT	UNIT COST	TOTAL COST
1500 S - 2290 Feet					
1450 W to 1100 W					
83	Mobilization - 10%	1	LS	\$392,091.13	\$392,091.13
84	Storm Water Pollution Prevention	1	LS	\$22,900.00	\$22,900.00
85	Traffic Control - 10%	1	LS	\$392,091.13	\$392,091.13
86	Clear and Grub	1	LS	\$18,320.00	\$18,320.00
87	Dust Control & Watering	1	LS	\$8,015.00	\$8,015.00
88	Survey - 3%	1	LS	\$117,627.34	\$117,627.34
89	Utilities (Contingency)	1	LS	\$196,045.56	\$196,045.56
90	Drainage Pipes and System	1	LS	\$549,600.00	\$549,600.00
91	Relocate Street Light	6	EA	\$1,500.00	\$9,000.00
92	Roadway Excavation (Plan Quantity)	61,250	CY	\$25.00	\$1,531,260.80
93	Remove Asphalt Pavement	10,178	SY	\$6.50	\$66,155.56
94	Relocate Sign	18	EA	\$200.00	\$3,600.00
95	Concrete Curb and Gutter	11,450	LF	\$28.00	\$320,600.00
96	HMA 6"	3,728	TON	\$150.00	\$559,218.00
97	Untreated Based Course 10"	4,170	CY	\$32.00	\$133,441.98
98	Granular Sub Base 12"	4,156	CY	\$28.00	\$116,365.93
99	Concrete Driveway	8,000	SF	\$20.00	\$160,000.00
100	Concrete Sidewalk	22,900	SF	\$15.00	\$343,500.00
101	Concrete Curb Ramp	13	EA	\$3,500.00	\$45,500.00
102	4" Paint Line	10,305	LF	\$1.00	\$10,305.00
103	Sod	27,480	SF	\$1.30	\$35,724.00
104	Topsoil-6 inch thick	3,053	SY	\$12.00	\$36,640.00
				SUBTOTAL	\$5,068,001.41
				ROW Acquisition	\$0.00
				Contingency - 35%	\$1,773,800.49
				Design Engineering - 10%	\$506,800.14
				Construction Engineering - 10%	\$506,800.14
				Miscellaneous Item - 5%	\$253,400.07
Total:					\$8,108,900.00

 ENGINEER'S OPINION OF PROBABLE COST					
PROJECT NAME: Woods Cross TMP		DATE: 2/4/2026			
PROJECT DESCRIPTION: Roadway Cost					
CLIENT: City of Woods Cross					
J-U-B PROJ. NO.: 07-24-094					
No.	ITEM	QUANTITY	UNIT	UNIT COST	TOTAL COST
1500 S - 1255 Feet					
1100 W to 950 W					
105	Mobilization - 10%	1	LS	\$211,839.55	\$211,839.55
106	Storm Water Pollution Prevention	1	LS	\$12,550.00	\$12,550.00
107	Traffic Control - 10%	1	LS	\$211,839.55	\$211,839.55
108	Clear and Grub	1	LS	\$10,040.00	\$10,040.00
109	Dust Control & Watering	1	LS	\$4,392.50	\$4,392.50
110	Survey - 3%	1	LS	\$63,551.86	\$63,551.86
111	Utilities (Contingency)	1	LS	\$105,919.77	\$105,919.77
112	Drainage Pipes and System	1	LS	\$301,200.00	\$301,200.00
113	Relocate Street Light	2	EA	\$1,500.00	\$3,000.00
114	Roadway Excavation (Plan Quantity)	33,567	CY	\$25.00	\$839,184.41
115	Remove Asphalt Pavement	6,136	SY	\$6.50	\$39,881.11
116	Relocate Sign	10	EA	\$200.00	\$2,000.00
117	Concrete Curb and Gutter	6,275	LF	\$28.00	\$175,700.00
118	HMA 6"	2,043	TON	\$150.00	\$306,471.00
119	Untreated Based Course 10"	2,285	CY	\$32.00	\$73,130.86
120	Granular Sub Base 12"	2,278	CY	\$28.00	\$63,772.59
121	Concrete Driveway	3,500	SF	\$20.00	\$70,000.00
122	Concrete Sidewalk	12,550	SF	\$15.00	\$188,250.00
123	Concrete Curb Ramp	3	EA	\$3,500.00	\$10,500.00
124	4" Paint Line	5,648	LF	\$1.00	\$5,647.50
125	Sod	15,060	SF	\$1.30	\$19,578.00
126	Topsoil-6 inch thick	1,673	SY	\$12.00	\$20,080.00
				SUBTOTAL	\$2,738,528.72
				ROW Acquisition	\$0.00
				Contingency - 35%	\$958,485.05
				Design Engineering - 10%	\$273,852.87
				Construction Engineering - 10%	\$273,852.87
				Miscellaneous Item - 5%	\$136,926.44
Total:					\$4,381,700.00

ENGINEER'S OPINION OF PROBABLE COST					
 J-U-B ENGINEERS, INC.					
PROJECT NAME: Woods Cross TMP				DATE: 2/4/2026	
PROJECT DESCRIPTION: Roadway Cost					
CLIENT: City of Woods Cross					
J-U-B PROJ. NO.: 07-24-094					
No.	ITEM	QUANTITY	UNIT	UNIT COST	TOTAL COST
1500 S - 1355 Feet					
950 W to 800 W					
127	Mobilization - 10%	1	LS	\$231,097.92	\$231,097.92
128	Storm Water Pollution Prevention	1	LS	\$13,550.00	\$13,550.00
129	Traffic Control - 10%	1	LS	\$231,097.92	\$231,097.92
130	Clear and Grub	1	LS	\$10,840.00	\$10,840.00
131	Dust Control & Watering	1	LS	\$4,742.50	\$4,742.50
132	Survey - 3%	1	LS	\$69,329.38	\$69,329.38
133	Utilities (Contingency)	1	LS	\$115,548.96	\$115,548.96
134	Drainage Pipes and System	1	LS	\$325,200.00	\$325,200.00
135	Relocate Street Light	6	EA	\$1,500.00	\$9,000.00
136	Roadway Excavation (Plan Quantity)	36,242	CY	\$25.00	\$906,051.70
137	Remove Asphalt Pavement	6,624	SY	\$6.50	\$43,058.89
138	Relocate Sign	13	EA	\$200.00	\$2,600.00
139	Concrete Curb and Gutter	6,775	LF	\$28.00	\$189,700.00
140	HMA 6"	2,206	TON	\$150.00	\$330,891.00
141	Untreated Based Course 10"	2,467	CY	\$32.00	\$78,958.02
142	Granular Sub Base 12"	2,459	CY	\$28.00	\$68,854.07
143	Concrete Driveway	4,000	SF	\$20.00	\$80,000.00
144	Concrete Sidewalk	13,550	SF	\$15.00	\$203,250.00
145	Concrete Curb Ramp	7	EA	\$3,500.00	\$24,500.00
146	4" Paint Line	6,098	LF	\$1.00	\$6,097.50
147	Sod	16,260	SF	\$1.30	\$21,138.00
148	Topsoil-6 inch thick	1,807	SY	\$12.00	\$21,680.00
				SUBTOTAL	\$2,987,185.86
				ROW Acquisition	\$0.00
				Contingency - 35%	\$1,045,515.05
				Design Engineering - 10%	\$298,718.59
				Construction Engineering - 10%	\$298,718.59
				Miscellaneous Item - 5%	\$149,359.29
Total:					\$4,779,500.00

 J-U-B ENGINEERS, INC.		ENGINEER'S OPINION OF PROBABLE COST			
PROJECT NAME: Woods Cross TMP		DATE: 2/4/2026			
PROJECT DESCRIPTION: Roadway Cost					
CLIENT: City of Woods Cross					
J-U-B PROJ. NO.: 07-24-094					
No.	ITEM	QUANTITY	UNIT	UNIT COST	TOTAL COST
1500 S - 1000 Feet					
800 W to 675 W					
149	Mobilization - 10%	1	LS	\$172,584.81	\$172,584.81
150	Storm Water Pollution Prevention	1	LS	\$10,000.00	\$10,000.00
151	Traffic Control - 10%	1	LS	\$172,584.81	\$172,584.81
152	Clear and Grub	1	LS	\$8,000.00	\$8,000.00
153	Dust Control & Watering	1	LS	\$3,500.00	\$3,500.00
154	Survey - 3%	1	LS	\$51,775.44	\$51,775.44
155	Utilities (Contingency)	1	LS	\$86,292.41	\$86,292.41
156	Drainage Pipes and System	1	LS	\$240,000.00	\$240,000.00
157	Relocate Street Light	7	EA	\$1,500.00	\$10,500.00
158	Roadway Excavation (Plan Quantity)	26,747	CY	\$25.00	\$668,672.84
159	Remove Asphalt Pavement	4,444	SY	\$6.50	\$28,888.89
160	Relocate Sign	12	EA	\$200.00	\$2,400.00
161	Concrete Curb and Gutter	5,000	LF	\$28.00	\$140,000.00
162	HMA 6"	1,628	TON	\$150.00	\$244,200.00
163	Untreated Based Course 10"	1,821	CY	\$32.00	\$58,271.60
164	Granular Sub Base 12"	1,815	CY	\$28.00	\$50,814.81
165	Concrete Driveway	3,750	SF	\$20.00	\$75,000.00
166	Concrete Sidewalk	10,000	SF	\$15.00	\$150,000.00
167	Concrete Curb Ramp	6	EA	\$3,500.00	\$21,000.00
168	4" Paint Line	4,500	LF	\$1.00	\$4,500.00
169	Sod	12,000	SF	\$1.30	\$15,600.00
170	Topsoil-6 inch thick	1,333	SY	\$12.00	\$16,000.00
				SUBTOTAL	\$2,230,585.63
				ROW Acquisition	\$0.00
				Contingency - 35%	\$780,704.97
				Design Engineering - 10%	\$223,058.56
				Construction Engineering - 10%	\$223,058.56
				Miscellaneous Item - 5%	\$111,529.28
Total:					\$3,569,000.00



J-U-B ENGINEERS, INC.

ENGINEER'S OPINION OF PROBABLE COST

PROJECT NAME:

DATE: 2/4/2026

Woods Cross TMP

PROJECT DESCRIPTION:

Roadway Cost

CLIENT:

City of Woods Cross

J-U-B PROJ. NO.: 07-24-094

No.	ITEM	QUANTITY	UNIT	UNIT COST	TOTAL COST
1500 S - 925 Feet					
675 W to 580 W					
171	Mobilization - 10%	1	LS	\$155,841.73	\$155,841.73
172	Storm Water Pollution Prevention	1	LS	\$9,250.00	\$9,250.00
173	Traffic Control - 10%	1	LS	\$155,841.73	\$155,841.73
174	Clear and Grub	1	LS	\$7,400.00	\$7,400.00
175	Dust Control & Watering	1	LS	\$3,237.50	\$3,237.50
176	Survey - 3%	1	LS	\$46,752.52	\$46,752.52
177	Drainage Pipes and System	1	LS	\$222,000.00	\$222,000.00
178	Relocate Street Light	3	EA	\$1,500.00	\$4,500.00
179	Roadway Excavation (Plan Quantity)	24,741	CY	\$25.00	\$618,522.38
180	Remove Asphalt Pavement	4,625	SY	\$6.50	\$30,062.50
181	Relocate Sign	2	EA	\$200.00	\$400.00
182	Concrete Curb and Gutter	4,625	LF	\$28.00	\$129,500.00
183	HMA 6"	1,506	TON	\$150.00	\$225,885.00
184	Untreated Based Course 10"	1,684	CY	\$32.00	\$53,901.23
185	Granular Sub Base 12"	1,679	CY	\$28.00	\$47,003.70
186	Concrete Driveway	1,500	SF	\$20.00	\$30,000.00
187	Concrete Sidewalk	9,250	SF	\$15.00	\$138,750.00
188	Concrete Curb Ramp	7	EA	\$3,500.00	\$24,500.00
189	4" Paint Line	4,163	LF	\$1.00	\$4,162.50
190	Sod	11,100	SF	\$1.30	\$14,430.00
191	Topsoil-6 inch thick	1,233	SY	\$12.00	\$14,800.00
				SUBTOTAL	\$1,936,740.80
				ROW Acquisition	\$0.00
				Contingency - 35%	\$677,859.28
				Design Engineering - 10%	\$193,674.08
				Construction Engineering - 10%	\$193,674.08
				Miscellaneous Item - 5%	\$96,837.04
				Total:	\$3,098,800.00

 ENGINEER'S OPINION OF PROBABLE COST					
PROJECT NAME:				DATE: 2/4/2026	
Woods Cross TMP					
PROJECT DESCRIPTION:					
Roadway Cost					
CLIENT:					
City of Woods Cross					
J-U-B PROJ. NO.: 07-24-094					
No.	ITEM	QUANTITY	UNIT	UNIT COST	TOTAL COST
1500 S - 645 Feet					
580 W to US-89					
192	Mobilization - 10%	1	LS	\$113,132.66	\$113,132.66
193	Storm Water Pollution Prevention	1	LS	\$6,450.00	\$6,450.00
194	Traffic Control - 10%	1	LS	\$113,132.66	\$113,132.66
195	Clear and Grub	1	LS	\$5,160.00	\$5,160.00
196	Dust Control & Watering	1	LS	\$2,257.50	\$2,257.50
197	Survey - 3%	1	LS	\$33,939.80	\$33,939.80
198	Drainage Pipes and System	1	LS	\$154,800.00	\$154,800.00
199	Relocate Street Light	2	EA	\$1,500.00	\$3,000.00
200	Roadway Excavation (Plan Quantity)	17,252	CY	\$25.00	\$431,293.98
201	Remove Asphalt Pavement	3,297	SY	\$6.50	\$21,428.33
202	Relocate Sign	8	EA	\$200.00	\$1,600.00
203	Concrete Curb and Gutter	3,225	LF	\$28.00	\$90,300.00
204	HMA 6"	1,050	TON	\$150.00	\$157,509.00
205	Untreated Based Course 10"	1,175	CY	\$32.00	\$37,585.19
206	Granular Sub Base 12"	1,171	CY	\$28.00	\$32,775.56
207	Concrete Driveway	3,000	SF	\$20.00	\$60,000.00
208	Concrete Sidewalk	6,450	SF	\$15.00	\$96,750.00
209	Concrete Curb Ramp	6	EA	\$3,500.00	\$21,000.00
210	4" Paint Line	2,903	LF	\$1.00	\$2,902.50
211	Sod	7,740	SF	\$1.30	\$10,062.00
212	Topsoil-6 inch thick	860	SY	\$12.00	\$10,320.00
				SUBTOTAL	\$1,405,399.16
				ROW Acquisition	\$0.00
				Contingency - 35%	\$491,889.71
				Design Engineering - 10%	\$140,539.92
				Construction Engineering - 10%	\$140,539.92
				Miscellaneous Item - 5%	\$70,269.96
				Total:	\$2,248,700.00

 ENGINEER'S OPINION OF PROBABLE COST					
PROJECT NAME: Woods Cross TMP					DATE: 2/4/2026
PROJECT DESCRIPTION: Roadway Cost					
CLIENT: City of Woods Cross					
J-U-B PROJ. NO.: 07-24-094					
No.	ITEM	QUANTITY	UNIT	UNIT COST	TOTAL COST
1500 S - 1010 Feet					
US-89 to 400 W					
213	Mobilization - 10%	1	LS	\$174,209.43	\$174,209.43
214	Storm Water Pollution Prevention	1	LS	\$10,100.00	\$10,100.00
215	Traffic Control - 10%	1	LS	\$174,209.43	\$174,209.43
216	Clear and Grub	1	LS	\$8,080.00	\$8,080.00
217	Dust Control & Watering	1	LS	\$3,535.00	\$3,535.00
218	Survey - 3%	1	LS	\$52,262.83	\$52,262.83
219	Drainage Pipes and System	1	LS	\$242,400.00	\$242,400.00
220	Relocate Street Light	6	EA	\$1,500.00	\$9,000.00
221	Roadway Excavation (Plan Quantity)	27,014	CY	\$25.00	\$675,359.57
222	Remove Asphalt Pavement	5,162	SY	\$6.50	\$33,554.44
223	Relocate Sign	8	EA	\$200.00	\$1,600.00
224	Concrete Curb and Gutter	5,050	LF	\$28.00	\$141,400.00
225	HMA 6"	1,644	TON	\$150.00	\$246,642.00
226	Untreated Based Course 10"	1,839	CY	\$32.00	\$58,854.32
227	Granular Sub Base 12"	1,833	CY	\$28.00	\$51,322.96
228	Concrete Driveway	4,000	SF	\$20.00	\$80,000.00
229	Concrete Sidewalk	10,100	SF	\$15.00	\$151,500.00
230	Concrete Curb Ramp	4	EA	\$3,500.00	\$14,000.00
231	4" Paint Line	4,545	LF	\$1.00	\$4,545.00
232	Sod	12,120	SF	\$1.30	\$15,756.00
233	Topsoil-6 inch thick	1,347	SY	\$12.00	\$16,160.00
				SUBTOTAL	\$2,164,490.98
				ROW Acquisition	\$0.00
				Contingency - 35%	\$757,571.84
				Design Engineering - 10%	\$216,449.10
				Construction Engineering - 10%	\$216,449.10
				Miscellaneous Item - 5%	\$108,224.55
Total:					\$3,463,200.00

 ENGINEER'S OPINION OF PROBABLE COST					
PROJECT NAME: Woods Cross TMP				DATE: 2/4/2026	
PROJECT DESCRIPTION: Roadway Cost					
CLIENT: City of Woods Cross					
J-U-B PROJ. NO.: 07-24-094					
No.	ITEM	QUANTITY	UNIT	UNIT COST	TOTAL COST
1950 S - 550 Feet					
1250 W to 1175 W					
1	Mobilization - 10%	1	LS	\$85,462.23	\$85,462.23
2	Storm Water Pollution Prevention	1	LS	\$5,500.00	\$5,500.00
3	Traffic Control - 10%	1	LS	\$85,462.23	\$85,462.23
4	Clear and Grub	1	LS	\$4,400.00	\$4,400.00
5	Dust Control & Watering	1	LS	\$1,925.00	\$1,925.00
6	Survey - 3%	1	LS	\$25,638.67	\$25,638.67
7	Utilities (Contingency)	1	LS	\$42,731.12	\$42,731.12
8	Drainage Pipes and System	1	LS	\$132,000.00	\$132,000.00
9	Relocate Street Light	1	EA	\$1,500.00	\$1,500.00
10	Roadway Excavation (Plan Quantity)	13,774	CY	\$25.00	\$344,344.14
11	Remove Asphalt Pavement	2,444	SY	\$6.50	\$15,888.89
12	Concrete Curb and Gutter	2,750	LF	\$28.00	\$77,000.00
13	HMA 6"	834	TON	\$150.00	\$125,152.50
14	Untreated Based Course 10"	951	CY	\$32.00	\$30,419.75
15	Granular Sub Base 12"	937	CY	\$28.00	\$26,237.04
16	Concrete Sidewalk	5,500	SF	\$15.00	\$82,500.00
17	4" Paint Line	2,200	LF	\$1.00	\$2,200.00
18	Sod	6,600	SF	\$1.30	\$8,580.00
19	Topsoil-6 inch thick	733	SY	\$12.00	\$8,800.00
				SUBTOTAL	\$1,105,741.56
				ROW Acquisition	\$0.00
				Contingency - 35%	\$387,009.55
				Design Engineering - 10%	\$110,574.16
				Construction Engineering - 10%	\$110,574.16
				Miscellaneous Item - 5%	\$55,287.08
Total:					\$1,769,200.00

 ENGINEER'S OPINION OF PROBABLE COST					
PROJECT NAME: Woods Cross TMP					DATE: 2/4/2026
PROJECT DESCRIPTION: Roadway Cost					
CLIENT: City of Woods Cross					
J-U-B PROJ. NO.: 07-24-094					
No.	ITEM	QUANTITY	UNIT	UNIT COST	TOTAL COST
1950 S - 375 Feet					
1175 W to 1100 W					
20	Mobilization - 10%	1	LS	\$58,707.43	\$58,707.43
21	Storm Water Pollution Prevention	1	LS	\$3,750.00	\$3,750.00
22	Traffic Control - 10%	1	LS	\$58,707.43	\$58,707.43
23	Clear and Grub	1	LS	\$3,000.00	\$3,000.00
24	Dust Control & Watering	1	LS	\$1,312.50	\$1,312.50
25	Survey - 3%	1	LS	\$17,612.23	\$17,612.23
26	Drainage Pipes and System	1	LS	\$90,000.00	\$90,000.00
27	Roadway Excavation (Plan Quantity)	9,391	CY	\$25.00	\$234,780.09
28	Remove Asphalt Pavement	1,667	SY	\$6.50	\$10,833.33
29	Relocate Sign	2	EA	\$200.00	\$400.00
30	Concrete Curb and Gutter	1,875	LF	\$28.00	\$52,500.00
31	HMA 6"	569	TON	\$150.00	\$85,331.25
32	Untreated Based Course 10"	648	CY	\$32.00	\$20,740.74
33	Granular Sub Base 12"	639	CY	\$28.00	\$17,888.89
34	Concrete Driveway	250	SF	\$20.00	\$5,000.00
35	Concrete Sidewalk	3,750	SF	\$15.00	\$56,250.00
36	4" Paint Line	1,500	LF	\$1.00	\$1,500.00
37	Sod	4,500	SF	\$1.30	\$5,850.00
38	Topsoil-6 inch thick	500	SY	\$12.00	\$6,000.00
				SUBTOTAL	\$730,163.90
				ROW Acquisition	\$0.00
				Contingency - 35%	\$255,557.36
				Design Engineering - 10%	\$73,016.39
				Construction Engineering - 10%	\$73,016.39
				Miscellaneous Item - 5%	\$36,508.19
Total:					\$1,168,300.00

 ENGINEER'S OPINION OF PROBABLE COST					
PROJECT NAME: Woods Cross TMP					DATE: 2/4/2026
PROJECT DESCRIPTION: Roadway Cost					
CLIENT: City of Woods Cross					
J-U-B PROJ. NO.: 07-24-094					
No.	ITEM	QUANTITY	UNIT	UNIT COST	TOTAL COST
400 S - 700 Feet					
1900 W to 1775 W					
1	Mobilization - 10%	1	LS	\$106,556.98	\$106,556.98
2	Storm Water Pollution Prevention	1	LS	\$7,000.00	\$7,000.00
3	Traffic Control - 10%	1	LS	\$106,556.98	\$106,556.98
4	Clear and Grub	1	LS	\$5,600.00	\$5,600.00
5	Dust Control & Watering	1	LS	\$2,450.00	\$2,450.00
6	Survey - 3%	1	LS	\$31,967.09	\$31,967.09
7	Drainage Pipes and System	1	LS	\$168,000.00	\$168,000.00
8	Roadway Excavation (Plan Quantity)	17,530	CY	\$25.00	\$438,256.17
9	Concrete Curb and Gutter	3,500	LF	\$28.00	\$98,000.00
10	HMA 6"	1,062	TON	\$150.00	\$159,285.00
11	Untreated Based Course 10"	1,210	CY	\$32.00	\$38,716.05
12	Granular Sub Base 12"	1,193	CY	\$28.00	\$33,392.59
13	Concrete Sidewalk	7,000	SF	\$15.00	\$105,000.00
14	4" Paint Line	2,800	LF	\$1.00	\$2,800.00
15	Sod	8,400	SF	\$1.30	\$10,920.00
16	Topsoil-6 inch thick	933	SY	\$12.00	\$11,200.00
				SUBTOTAL	\$1,325,700.87
				ROW Acquisition	\$0.00
				Contingency - 35%	\$463,995.31
				Design Engineering - 10%	\$132,570.09
				Construction Engineering - 10%	\$132,570.09
				Miscellaneous Item - 5%	\$66,285.04
Total:					\$2,121,200.00

 ENGINEER'S OPINION OF PROBABLE COST					
PROJECT NAME: Woods Cross TMP					DATE: 2/4/2026
PROJECT DESCRIPTION: Roadway Cost					
CLIENT: City of Woods Cross					
J-U-B PROJ. NO.: 07-24-094					
No.	ITEM	QUANTITY	UNIT	UNIT COST	TOTAL COST
400 S - 430 Feet					
1775 W to 1650 W					
17	Mobilization - 10%	1	LS	\$65,456.43	\$65,456.43
18	Storm Water Pollution Prevention	1	LS	\$4,300.00	\$4,300.00
19	Traffic Control - 10%	1	LS	\$65,456.43	\$65,456.43
20	Clear and Grub	1	LS	\$3,440.00	\$3,440.00
21	Dust Control & Watering	1	LS	\$1,505.00	\$1,505.00
22	Survey - 3%	1	LS	\$19,636.93	\$19,636.93
23	Drainage Pipes and System	1	LS	\$103,200.00	\$103,200.00
24	Roadway Excavation (Plan Quantity)	10,769	CY	\$25.00	\$269,214.51
25	Concrete Curb and Gutter	2,150	LF	\$28.00	\$60,200.00
26	HMA 6"	652	TON	\$150.00	\$97,846.50
27	Untreated Based Course 10"	743	CY	\$32.00	\$23,782.72
28	Granular Sub Base 12"	733	CY	\$28.00	\$20,512.59
29	Concrete Sidewalk	4,300	SF	\$15.00	\$64,500.00
30	4" Paint Line	1,720	LF	\$1.00	\$1,720.00
31	Sod	5,160	SF	\$1.30	\$6,708.00
32	Topsoil-6 inch thick	573	SY	\$12.00	\$6,880.00
				SUBTOTAL	\$814,359.11
				ROW Acquisition	\$0.00
				Contingency - 35%	\$285,025.69
				Design Engineering - 10%	\$81,435.91
				Construction Engineering - 10%	\$81,435.91
				Miscellaneous Item - 5%	\$40,717.96
Total:					\$1,303,000.00

 ENGINEER'S OPINION OF PROBABLE COST					
PROJECT NAME: Woods Cross TMP					DATE: 2/4/2026
PROJECT DESCRIPTION: Roadway Cost					
CLIENT: City of Woods Cross					
J-U-B PROJ. NO.: 07-24-094					
No.	ITEM	QUANTITY	UNIT	UNIT COST	TOTAL COST
400 S - 165 Feet					
1650 W to 1625 W					
33	Mobilization - 10%	1	LS	\$25,117.00	\$25,117.00
34	Storm Water Pollution Prevention	1	LS	\$1,650.00	\$1,650.00
35	Traffic Control - 10%	1	LS	\$25,117.00	\$25,117.00
36	Clear and Grub	1	LS	\$1,320.00	\$1,320.00
37	Dust Control & Watering	1	LS	\$577.50	\$577.50
38	Survey - 3%	1	LS	\$7,535.10	\$7,535.10
39	Drainage Pipes and System	1	LS	\$39,600.00	\$39,600.00
40	Roadway Excavation (Plan Quantity)	4,132	CY	\$25.00	\$103,303.24
41	Concrete Curb and Gutter	825	LF	\$28.00	\$23,100.00
42	HMA 6"	250	TON	\$150.00	\$37,545.75
43	Untreated Based Course 10"	285	CY	\$32.00	\$9,125.93
44	Granular Sub Base 12"	281	CY	\$28.00	\$7,871.11
45	Concrete Sidewalk	1,650	SF	\$15.00	\$24,750.00
46	4" Paint Line	660	LF	\$1.00	\$660.00
47	Sod	1,980	SF	\$1.30	\$2,574.00
48	Topsoil-6 inch thick	220	SY	\$12.00	\$2,640.00
				SUBTOTAL	\$312,486.63
				ROW Acquisition	\$0.00
				Contingency - 35%	\$109,370.32
				Design Engineering - 10%	\$31,248.66
				Construction Engineering - 10%	\$31,248.66
				Miscellaneous Item - 5%	\$15,624.33
				Total:	\$500,000.00

ENGINEER'S OPINION OF PROBABLE COST					
					
J-U-B ENGINEERS, INC.					
PROJECT NAME: Woods Cross TMP				DATE: 2/4/2026	
PROJECT DESCRIPTION: Roadway Cost					
CLIENT: City of Woods Cross					
J-U-B PROJ. NO.: 07-24-094					
No.	ITEM	QUANTITY	UNIT	UNIT COST	TOTAL COST
400 S - 165 Feet					
1625 W to 1600 W					
49	Mobilization - 10%	1	LS	\$25,117.00	\$25,117.00
50	Storm Water Pollution Prevention	1	LS	\$1,650.00	\$1,650.00
51	Traffic Control - 10%	1	LS	\$25,117.00	\$25,117.00
52	Clear and Grub	1	LS	\$1,320.00	\$1,320.00
53	Dust Control & Watering	1	LS	\$577.50	\$577.50
54	Survey - 3%	1	LS	\$7,535.10	\$7,535.10
55	Utilities (Contingency)	1	LS	\$12,558.50	\$12,558.50
56	Drainage Pipes and System	1	LS	\$39,600.00	\$39,600.00
57	Roadway Excavation (Plan Quantity)	4,132	CY	\$25.00	\$103,303.24
58	Concrete Curb and Gutter	825	LF	\$28.00	\$23,100.00
59	HMA 6"	250	TON	\$150.00	\$37,545.75
60	Untreated Based Course 10"	285	CY	\$32.00	\$9,125.93
61	Granular Sub Base 12"	281	CY	\$28.00	\$7,871.11
62	Concrete Sidewalk	1,650	SF	\$15.00	\$24,750.00
63	4" Paint Line	660	LF	\$1.00	\$660.00
64	Sod	1,980	SF	\$1.30	\$2,574.00
65	Topsoil-6 inch thick	220	SY	\$12.00	\$2,640.00
				SUBTOTAL	\$325,045.14
				ROW Acquisition	\$0.00
				Contingency - 35%	\$113,765.80
				Design Engineering - 10%	\$32,504.51
				Construction Engineering - 10%	\$32,504.51
				Miscellaneous Item - 5%	\$16,252.26
				Total:	\$520,100.00

 ENGINEER'S OPINION OF PROBABLE COST					
PROJECT NAME: Woods Cross TMP					DATE: 2/4/2026
PROJECT DESCRIPTION: Roadway Cost					
CLIENT: City of Woods Cross					
J-U-B PROJ. NO.: 07-24-094					
No.	ITEM	QUANTITY	UNIT	UNIT COST	TOTAL COST
400 S - 500 Feet					
1600 W to 1525 W					
66	Mobilization - 10%	1	LS	\$76,112.13	\$76,112.13
67	Storm Water Pollution Prevention	1	LS	\$5,000.00	\$5,000.00
68	Traffic Control - 10%	1	LS	\$76,112.13	\$76,112.13
69	Clear and Grub	1	LS	\$4,000.00	\$4,000.00
70	Dust Control & Watering	1	LS	\$1,750.00	\$1,750.00
71	Survey - 3%	1	LS	\$22,833.64	\$22,833.64
72	Utilities (Contingency)	1	LS	\$38,056.06	\$38,056.06
73	Drainage Pipes and System	1	LS	\$120,000.00	\$120,000.00
74	Roadway Excavation (Plan Quantity)	12,522	CY	\$25.00	\$313,040.12
75	Concrete Curb and Gutter	2,500	LF	\$28.00	\$70,000.00
76	HMA 6"	759	TON	\$150.00	\$113,775.00
77	Untreated Based Course 10"	864	CY	\$32.00	\$27,654.32
78	Granular Sub Base 12"	852	CY	\$28.00	\$23,851.85
79	Concrete Sidewalk	5,000	SF	\$15.00	\$75,000.00
80	4" Paint Line	2,000	LF	\$1.00	\$2,000.00
81	Sod	6,000	SF	\$1.30	\$7,800.00
82	Topsoil-6 inch thick	667	SY	\$12.00	\$8,000.00
				SUBTOTAL	\$984,985.26
				ROW Acquisition	\$0.00
				Contingency - 35%	\$344,744.84
				Design Engineering - 10%	\$98,498.53
				Construction Engineering - 10%	\$98,498.53
				Miscellaneous Item - 5%	\$49,249.26
Total:					\$1,576,000.00

 ENGINEER'S OPINION OF PROBABLE COST					
PROJECT NAME: Woods Cross TMP					DATE: 2/4/2026
PROJECT DESCRIPTION: Roadway Cost					
CLIENT: City of Woods Cross					
J-U-B PROJ. NO.: 07-24-094					
No.	ITEM	QUANTITY	UNIT	UNIT COST	TOTAL COST
400 S - 400 Feet					
1525 W to 1450 W					
83	Mobilization - 10%	1	LS	\$60,889.70	\$60,889.70
84	Storm Water Pollution Prevention	1	LS	\$4,000.00	\$4,000.00
85	Traffic Control - 10%	1	LS	\$60,889.70	\$60,889.70
86	Clear and Grub	1	LS	\$3,200.00	\$3,200.00
87	Dust Control & Watering	1	LS	\$1,400.00	\$1,400.00
88	Survey - 3%	1	LS	\$18,266.91	\$18,266.91
89	Utilities (Contingency)	1	LS	\$30,444.85	\$30,444.85
90	Drainage Pipes and System	1	LS	\$96,000.00	\$96,000.00
91	Roadway Excavation (Plan Quantity)	10,017	CY	\$25.00	\$250,432.10
92	Concrete Curb and Gutter	2,000	LF	\$28.00	\$56,000.00
93	HMA 6"	607	TON	\$150.00	\$91,020.00
94	Untreated Based Course 10"	691	CY	\$32.00	\$22,123.46
95	Granular Sub Base 12"	681	CY	\$28.00	\$19,081.48
96	Concrete Sidewalk	4,000	SF	\$15.00	\$60,000.00
97	4" Paint Line	1,600	LF	\$1.00	\$1,600.00
98	Sod	4,800	SF	\$1.30	\$6,240.00
99	Topsoil-6 inch thick	533	SY	\$12.00	\$6,400.00
				SUBTOTAL	\$787,988.21
				ROW Acquisition	\$0.00
				Contingency - 35%	\$275,795.87
				Design Engineering - 10%	\$78,798.82
				Construction Engineering - 10%	\$78,798.82
				Miscellaneous Item - 5%	\$39,399.41
Total:					\$1,260,800.00

 ENGINEER'S OPINION OF PROBABLE COST					
PROJECT NAME: Woods Cross TMP					DATE: 2/4/2026
PROJECT DESCRIPTION: Roadway Cost					
CLIENT: City of Woods Cross					
J-U-B PROJ. NO.: 07-24-094					
No.	ITEM	QUANTITY	UNIT	UNIT COST	TOTAL COST
400 S - 1655 Feet					
1450 W to 1275 W					
100	Mobilization - 10%	1	LS	\$251,931.15	\$251,931.15
101	Storm Water Pollution Prevention	1	LS	\$16,550.00	\$16,550.00
102	Traffic Control - 10%	1	LS	\$251,931.15	\$251,931.15
103	Clear and Grub	1	LS	\$13,240.00	\$13,240.00
104	Dust Control & Watering	1	LS	\$5,792.50	\$5,792.50
105	Survey - 3%	1	LS	\$75,579.34	\$75,579.34
106	Utilities (Contingency)	1	LS	\$125,965.57	\$125,965.57
107	Drainage Pipes and System	1	LS	\$397,200.00	\$397,200.00
108	Roadway Excavation (Plan Quantity)	41,447	CY	\$25.00	\$1,036,162.81
109	Concrete Curb and Gutter	8,275	LF	\$28.00	\$231,700.00
110	HMA 6"	2,511	TON	\$150.00	\$376,595.25
111	Untreated Based Course 10"	2,860	CY	\$32.00	\$91,535.80
112	Granular Sub Base 12"	2,820	CY	\$28.00	\$78,949.63
113	Concrete Sidewalk	16,550	SF	\$15.00	\$248,250.00
114	4" Paint Line	6,620	LF	\$1.00	\$6,620.00
115	Sod	19,860	SF	\$1.30	\$25,818.00
116	Topsoil-6 inch thick	2,207	SY	\$12.00	\$26,480.00
SUBTOTAL					\$3,260,301.21
ROW Acquisition					\$0.00
Contingency - 35%					\$1,141,105.42
Design Engineering - 10%					\$326,030.12
Construction Engineering - 10%					\$326,030.12
Miscellaneous Item - 5%					\$163,015.06
Total:					\$5,216,500.00

ENGINEER'S OPINION OF PROBABLE COST					
					
PROJECT NAME: Woods Cross TMP		DATE: 2/4/2026			
PROJECT DESCRIPTION: Roadway Cost					
CLIENT: City of Woods Cross					
J-U-B PROJ. NO.: 07-24-094					
No.	ITEM	QUANTITY	UNIT	UNIT COST	TOTAL COST
750 S - 300 Feet					
Mountain View Blvd to 2000 W					
1	Mobilization - 10%	1	LS	\$45,667.28	\$45,667.28
2	Storm Water Pollution Prevention	1	LS	\$3,000.00	\$3,000.00
3	Traffic Control - 10%	1	LS	\$45,667.28	\$45,667.28
4	Clear and Grub	1	LS	\$2,400.00	\$2,400.00
5	Dust Control & Watering	1	LS	\$1,050.00	\$1,050.00
6	Survey - 3%	1	LS	\$13,700.18	\$13,700.18
7	Drainage Pipes and System	1	LS	\$72,000.00	\$72,000.00
8	Roadway Excavation (Plan Quantity)	7,513	CY	\$25.00	\$187,824.07
9	Concrete Curb and Gutter	1,500	LF	\$28.00	\$42,000.00
10	HMA 6"	455	TON	\$150.00	\$68,265.00
11	Untreated Based Course 10"	519	CY	\$32.00	\$16,592.59
12	Granular Sub Base 12"	511	CY	\$28.00	\$14,311.11
13	Concrete Sidewalk	3,000	SF	\$15.00	\$45,000.00
14	4" Paint Line	1,200	LF	\$1.00	\$1,200.00
15	Sod	3,600	SF	\$1.30	\$4,680.00
16	Topsoil-6 inch thick	400	SY	\$12.00	\$4,800.00
				SUBTOTAL	\$568,157.52
				ROW Acquisition	\$0.00
				Contingency - 35%	\$198,855.13
				Design Engineering - 10%	\$56,815.75
				Construction Engineering - 10%	\$56,815.75
				Miscellaneous Item - 5%	\$28,407.88
				Total:	\$909,100.00

 ENGINEER'S OPINION OF PROBABLE COST					
PROJECT NAME: Woods Cross TMP				DATE: 2/4/2026	
PROJECT DESCRIPTION: Roadway Cost					
CLIENT: City of Woods Cross					
J-U-B PROJ. NO.: 07-24-094					
No.	ITEM	QUANTITY	UNIT	UNIT COST	TOTAL COST
750 S - 630 Feet					
2000 W to 1900 W					
17	Mobilization - 10%	1	LS	\$95,901.28	\$95,901.28
18	Storm Water Pollution Prevention	1	LS	\$6,300.00	\$6,300.00
19	Traffic Control - 10%	1	LS	\$95,901.28	\$95,901.28
20	Clear and Grub	1	LS	\$5,040.00	\$5,040.00
21	Dust Control & Watering	1	LS	\$2,205.00	\$2,205.00
22	Survey - 3%	1	LS	\$28,770.39	\$28,770.39
23	Drainage Pipes and System	1	LS	\$151,200.00	\$151,200.00
24	Roadway Excavation (Plan Quantity)	15,777	CY	\$25.00	\$394,430.56
25	Concrete Curb and Gutter	3,150	LF	\$28.00	\$88,200.00
26	HMA 6"	956	TON	\$150.00	\$143,356.50
27	Untreated Based Course 10"	1,089	CY	\$32.00	\$34,844.44
28	Granular Sub Base 12"	1,073	CY	\$28.00	\$30,053.33
29	Concrete Sidewalk	6,300	SF	\$15.00	\$94,500.00
30	4" Paint Line	2,520	LF	\$1.00	\$2,520.00
31	Sod	7,560	SF	\$1.30	\$9,828.00
32	Topsoil-6 inch thick	840	SY	\$12.00	\$10,080.00
				SUBTOTAL	\$1,193,130.79
				ROW Acquisition	\$0.00
				Contingency - 35%	\$417,595.77
				Design Engineering - 10%	\$119,313.08
				Construction Engineering - 10%	\$119,313.08
				Miscellaneous Item - 5%	\$59,656.54
Total:					\$1,909,100.00

ENGINEER'S OPINION OF PROBABLE COST					
					
PROJECT NAME: Woods Cross TMP		DATE: 2/4/2026			
PROJECT DESCRIPTION: Roadway Cost					
CLIENT: City of Woods Cross					
J-U-B PROJ. NO.: 07-24-094					
No.	ITEM	QUANTITY	UNIT	UNIT COST	TOTAL COST
750 S - 710 Feet					
1900 W to Redwood Rd					
33	Mobilization - 10%	1	LS	\$108,079.22	\$108,079.22
34	Storm Water Pollution Prevention	1	LS	\$7,100.00	\$7,100.00
35	Traffic Control - 10%	1	LS	\$108,079.22	\$108,079.22
36	Clear and Grub	1	LS	\$5,680.00	\$5,680.00
37	Dust Control & Watering	1	LS	\$2,485.00	\$2,485.00
38	Survey - 3%	1	LS	\$32,423.77	\$32,423.77
39	Drainage Pipes and System	1	LS	\$170,400.00	\$170,400.00
40	Roadway Excavation (Plan Quantity)	17,781	CY	\$25.00	\$444,516.98
41	Concrete Curb and Gutter	3,550	LF	\$28.00	\$99,400.00
42	HMA 6"	1,077	TON	\$150.00	\$161,560.50
43	Untreated Based Course 10"	1,227	CY	\$32.00	\$39,269.14
44	Granular Sub Base 12"	1,210	CY	\$28.00	\$33,869.63
45	Concrete Sidewalk	7,100	SF	\$15.00	\$106,500.00
46	4" Paint Line	2,840	LF	\$1.00	\$2,840.00
47	Sod	8,520	SF	\$1.30	\$11,076.00
48	Topsoil-6 inch thick	947	SY	\$12.00	\$11,360.00
				SUBTOTAL	\$1,344,639.46
				ROW Acquisition	\$0.00
				Contingency - 35%	\$470,623.81
				Design Engineering - 10%	\$134,463.95
				Construction Engineering - 10%	\$134,463.95
				Miscellaneous Item - 5%	\$67,231.97
				Total:	\$2,151,500.00

ENGINEER'S OPINION OF PROBABLE COST					
					
PROJECT NAME: Woods Cross TMP				DATE: 2/4/2026	
PROJECT DESCRIPTION: Roadway Cost					
CLIENT: City of Woods Cross					
J-U-B PROJ. NO.: 07-24-094					
No.	ITEM	QUANTITY	UNIT	UNIT COST	TOTAL COST
750 S - 660 Feet					
Redwood Rd to 1650 W					
49	Mobilization - 10%	1	LS	\$100,468.01	\$100,468.01
50	Storm Water Pollution Prevention	1	LS	\$6,600.00	\$6,600.00
51	Traffic Control - 10%	1	LS	\$100,468.01	\$100,468.01
52	Clear and Grub	1	LS	\$5,280.00	\$5,280.00
53	Dust Control & Watering	1	LS	\$2,310.00	\$2,310.00
54	Survey - 3%	1	LS	\$30,140.40	\$30,140.40
55	Utilities (Contingency)	1	LS	\$50,234.01	\$50,234.01
56	Drainage Pipes and System	1	LS	\$158,400.00	\$158,400.00
57	Roadway Excavation (Plan Quantity)	16,529	CY	\$25.00	\$413,212.96
58	Concrete Curb and Gutter	3,300	LF	\$28.00	\$92,400.00
59	HMA 6"	1,001	TON	\$150.00	\$150,183.00
60	Untreated Based Course 10"	1,141	CY	\$32.00	\$36,503.70
61	Granular Sub Base 12"	1,124	CY	\$28.00	\$31,484.44
62	Concrete Sidewalk	6,600	SF	\$15.00	\$99,000.00
63	4" Paint Line	2,640	LF	\$1.00	\$2,640.00
64	Sod	7,920	SF	\$1.30	\$10,296.00
65	Topsoil-6 inch thick	880	SY	\$12.00	\$10,560.00
				SUBTOTAL	\$1,300,180.54
				ROW Acquisition	\$0.00
				Contingency - 35%	\$455,063.19
				Design Engineering - 10%	\$130,018.05
				Construction Engineering - 10%	\$130,018.05
				Miscellaneous Item - 5%	\$65,009.03
				Total:	\$2,080,300.00

 ENGINEER'S OPINION OF PROBABLE COST					
PROJECT NAME: Woods Cross TMP				DATE: 2/4/2026	
PROJECT DESCRIPTION: Roadway Cost					
CLIENT: City of Woods Cross					
J-U-B PROJ. NO.: 07-24-094					
No.	ITEM	QUANTITY	UNIT	UNIT COST	TOTAL COST
750 S - 530 Feet					
1650 W to 1600 W					
66	Mobilization - 10%	1	LS	\$80,678.86	\$80,678.86
67	Storm Water Pollution Prevention	1	LS	\$5,300.00	\$5,300.00
68	Traffic Control - 10%	1	LS	\$80,678.86	\$80,678.86
69	Clear and Grub	1	LS	\$4,240.00	\$4,240.00
70	Dust Control & Watering	1	LS	\$1,855.00	\$1,855.00
71	Survey - 3%	1	LS	\$24,203.66	\$24,203.66
72	Utilities (Contingency)	1	LS	\$40,339.43	\$40,339.43
73	Drainage Pipes and System	1	LS	\$127,200.00	\$127,200.00
74	Roadway Excavation (Plan Quantity)	13,273	CY	\$25.00	\$331,822.53
75	Concrete Curb and Gutter	2,650	LF	\$28.00	\$74,200.00
76	HMA 6"	804	TON	\$150.00	\$120,601.50
77	Untreated Based Course 10"	916	CY	\$32.00	\$29,313.58
78	Granular Sub Base 12"	903	CY	\$28.00	\$25,282.96
79	Concrete Sidewalk	5,300	SF	\$15.00	\$79,500.00
80	4" Paint Line	2,120	LF	\$1.00	\$2,120.00
81	Sod	6,360	SF	\$1.30	\$8,268.00
82	Topsoil-6 inch thick	707	SY	\$12.00	\$8,480.00
				SUBTOTAL	\$1,044,084.37
				ROW Acquisition	\$0.00
				Contingency - 35%	\$365,429.53
				Design Engineering - 10%	\$104,408.44
				Construction Engineering - 10%	\$104,408.44
				Miscellaneous Item - 5%	\$52,204.22
				Total:	\$1,670,600.00

ENGINEER'S OPINION OF PROBABLE COST					
					
PROJECT NAME: Woods Cross TMP				DATE: 2/4/2026	
PROJECT DESCRIPTION: Roadway Cost					
CLIENT: City of Woods Cross					
J-U-B PROJ. NO.: 07-24-094					
No.	ITEM	QUANTITY	UNIT	UNIT COST	TOTAL COST
750 S - 740 Feet					
1600 W to 1525 W					
83	Mobilization - 10%	1	LS	\$112,645.95	\$112,645.95
84	Storm Water Pollution Prevention	1	LS	\$7,400.00	\$7,400.00
85	Traffic Control - 10%	1	LS	\$112,645.95	\$112,645.95
86	Clear and Grub	1	LS	\$5,920.00	\$5,920.00
87	Dust Control & Watering	1	LS	\$2,590.00	\$2,590.00
88	Survey - 3%	1	LS	\$33,793.79	\$33,793.79
89	Utilities (Contingency)	1	LS	\$56,322.98	\$56,322.98
90	Drainage Pipes and System	1	LS	\$177,600.00	\$177,600.00
91	Roadway Excavation (Plan Quantity)	18,532	CY	\$25.00	\$463,299.38
92	Concrete Curb and Gutter	3,700	LF	\$28.00	\$103,600.00
93	HMA 6"	1,123	TON	\$150.00	\$168,387.00
94	Untreated Based Course 10"	1,279	CY	\$32.00	\$40,928.40
95	Granular Sub Base 12"	1,261	CY	\$28.00	\$35,300.74
96	Concrete Sidewalk	7,400	SF	\$15.00	\$111,000.00
97	4" Paint Line	2,960	LF	\$1.00	\$2,960.00
98	Sod	8,880	SF	\$1.30	\$11,544.00
99	Topsoil-6 inch thick	987	SY	\$12.00	\$11,840.00
				SUBTOTAL	\$1,457,778.18
				ROW Acquisition	\$0.00
				Contingency - 35%	\$510,222.36
				Design Engineering - 10%	\$145,777.82
				Construction Engineering - 10%	\$145,777.82
				Miscellaneous Item - 5%	\$72,888.91
				Total:	\$2,332,500.00

ENGINEER'S OPINION OF PROBABLE COST					
					
PROJECT NAME: Woods Cross TMP				DATE: 2/4/2026	
PROJECT DESCRIPTION: Roadway Cost					
CLIENT: City of Woods Cross					
J-U-B PROJ. NO.: 07-24-094					
No.	ITEM	QUANTITY	UNIT	UNIT COST	TOTAL COST
750 S - 530 Feet					
1525 W to 1450 W					
100	Mobilization - 10%	1	LS	\$80,678.86	\$80,678.86
101	Storm Water Pollution Prevention	1	LS	\$5,300.00	\$5,300.00
102	Traffic Control - 10%	1	LS	\$80,678.86	\$80,678.86
103	Clear and Grub	1	LS	\$4,240.00	\$4,240.00
104	Dust Control & Watering	1	LS	\$1,855.00	\$1,855.00
105	Survey - 3%	1	LS	\$24,203.66	\$24,203.66
106	Utilities (Contingency)	1	LS	\$40,339.43	\$40,339.43
107	Drainage Pipes and System	1	LS	\$127,200.00	\$127,200.00
108	Roadway Excavation (Plan Quantity)	13,273	CY	\$25.00	\$331,822.53
109	Concrete Curb and Gutter	2,650	LF	\$28.00	\$74,200.00
110	HMA 6"	804	TON	\$150.00	\$120,601.50
111	Untreated Based Course 10"	916	CY	\$32.00	\$29,313.58
112	Granular Sub Base 12"	903	CY	\$28.00	\$25,282.96
113	Concrete Sidewalk	5,300	SF	\$15.00	\$79,500.00
114	4" Paint Line	2,120	LF	\$1.00	\$2,120.00
115	Sod	6,360	SF	\$1.30	\$8,268.00
116	Topsoil-6 inch thick	707	SY	\$12.00	\$8,480.00
				SUBTOTAL	\$1,044,084.37
				ROW Acquisition	\$0.00
				Contingency - 35%	\$365,429.53
				Design Engineering - 10%	\$104,408.44
				Construction Engineering - 10%	\$104,408.44
				Miscellaneous Item - 5%	\$52,204.22
				Total:	\$1,670,600.00

ENGINEER'S OPINION OF PROBABLE COST					
					
PROJECT NAME: Woods Cross TMP		DATE: 2/4/2026			
PROJECT DESCRIPTION: Roadway Cost					
CLIENT: City of Woods Cross					
J-U-B PROJ. NO.: 07-24-094					
No.	ITEM	QUANTITY	UNIT	UNIT COST	TOTAL COST
750 S - 1350 Feet					
1450 W to 1275 W					
117	Mobilization - 10%	1	LS	\$205,502.75	\$205,502.75
118	Storm Water Pollution Prevention	1	LS	\$13,500.00	\$13,500.00
119	Traffic Control - 10%	1	LS	\$205,502.75	\$205,502.75
120	Clear and Grub	1	LS	\$10,800.00	\$10,800.00
121	Dust Control & Watering	1	LS	\$4,725.00	\$4,725.00
122	Survey - 3%	1	LS	\$61,650.83	\$61,650.83
123	Utilities (Contingency)	1	LS	\$102,751.38	\$102,751.38
124	Drainage Pipes and System	1	LS	\$324,000.00	\$324,000.00
125	Roadway Excavation (Plan Quantity)	33,808	CY	\$25.00	\$845,208.33
126	Concrete Curb and Gutter	6,750	LF	\$28.00	\$189,000.00
127	HMA 6"	2,048	TON	\$150.00	\$307,192.50
128	Untreated Based Course 10"	2,333	CY	\$32.00	\$74,666.67
129	Granular Sub Base 12"	2,300	CY	\$28.00	\$64,400.00
130	Concrete Sidewalk	13,500	SF	\$15.00	\$202,500.00
131	4" Paint Line	5,400	LF	\$1.00	\$5,400.00
132	Sod	16,200	SF	\$1.30	\$21,060.00
133	Topsoil-6 inch thick	1,800	SY	\$12.00	\$21,600.00
				SUBTOTAL	\$2,659,460.20
				ROW Acquisition	\$0.00
				Contingency - 35%	\$930,811.07
				Design Engineering - 10%	\$265,946.02
				Construction Engineering - 10%	\$265,946.02
				Miscellaneous Item - 5%	\$132,973.01
				Total:	\$4,255,200.00

ENGINEER'S OPINION OF PROBABLE COST					
					
PROJECT NAME: Woods Cross TMP		DATE: 2/4/2026			
PROJECT DESCRIPTION: Roadway Cost					
CLIENT: City of Woods Cross					
J-U-B PROJ. NO.: 07-24-094					
No.	ITEM	QUANTITY	UNIT	UNIT COST	TOTAL COST
750 S - 1160 Feet					
1275 W to 1100 W					
134	Mobilization - 10%	1	LS	\$176,580.14	\$176,580.14
135	Storm Water Pollution Prevention	1	LS	\$11,600.00	\$11,600.00
136	Traffic Control - 10%	1	LS	\$176,580.14	\$176,580.14
137	Clear and Grub	1	LS	\$9,280.00	\$9,280.00
138	Dust Control & Watering	1	LS	\$4,060.00	\$4,060.00
139	Survey - 3%	1	LS	\$52,974.04	\$52,974.04
140	Drainage Pipes and System	1	LS	\$278,400.00	\$278,400.00
141	Roadway Excavation (Plan Quantity)	29,050	CY	\$25.00	\$726,253.09
142	Concrete Curb and Gutter	5,800	LF	\$28.00	\$162,400.00
143	HMA 6"	1,760	TON	\$150.00	\$263,958.00
144	Untreated Based Course 10"	2,005	CY	\$32.00	\$64,158.02
145	Granular Sub Base 12"	1,976	CY	\$28.00	\$55,336.30
146	Concrete Sidewalk	11,600	SF	\$15.00	\$174,000.00
147	4" Paint Line	4,640	LF	\$1.00	\$4,640.00
148	Sod	13,920	SF	\$1.30	\$18,096.00
149	Topsoil-6 inch thick	1,547	SY	\$12.00	\$18,560.00
				SUBTOTAL	\$2,196,875.73
				ROW Acquisition	\$0.00
				Contingency - 35%	\$768,906.51
				Design Engineering - 10%	\$219,687.57
				Construction Engineering - 10%	\$219,687.57
				Miscellaneous Item - 5%	\$109,843.79
Total:					\$3,515,100.00

 ENGINEER'S OPINION OF PROBABLE COST					
PROJECT NAME: Woods Cross TMP					DATE: 2/4/2026
PROJECT DESCRIPTION: Roadway Cost					
CLIENT: City of Woods Cross					
J-U-B PROJ. NO.: 07-24-094					
No.	ITEM	QUANTITY	UNIT	UNIT COST	TOTAL COST
1050 S - 300 Feet					
Mountain View Blvd to 2000 W					
1	Mobilization - 10%	1	LS	\$45,667.28	\$45,667.28
2	Storm Water Pollution Prevention	1	LS	\$3,000.00	\$3,000.00
3	Traffic Control - 10%	1	LS	\$45,667.28	\$45,667.28
4	Clear and Grub	1	LS	\$2,400.00	\$2,400.00
5	Dust Control & Watering	1	LS	\$1,050.00	\$1,050.00
6	Survey - 3%	1	LS	\$13,700.18	\$13,700.18
7	Drainage Pipes and System	1	LS	\$72,000.00	\$72,000.00
8	Roadway Excavation (Plan Quantity)	7,513	CY	\$25.00	\$187,824.07
9	Concrete Curb and Gutter	1,500	LF	\$28.00	\$42,000.00
10	HMA 6"	455	TON	\$150.00	\$68,265.00
11	Untreated Based Course 10"	519	CY	\$32.00	\$16,592.59
12	Granular Sub Base 12"	511	CY	\$28.00	\$14,311.11
13	Concrete Sidewalk	3,000	SF	\$15.00	\$45,000.00
14	4" Paint Line	1,200	LF	\$1.00	\$1,200.00
15	Sod	3,600	SF	\$1.30	\$4,680.00
16	Topsoil-6 inch thick	400	SY	\$12.00	\$4,800.00
				SUBTOTAL	\$568,157.52
				ROW Acquisition	\$0.00
				Contingency - 35%	\$198,855.13
				Design Engineering - 10%	\$56,815.75
				Construction Engineering - 10%	\$56,815.75
				Miscellaneous Item - 5%	\$28,407.88
				Total:	\$909,100.00

 ENGINEER'S OPINION OF PROBABLE COST					
PROJECT NAME: Woods Cross TMP					DATE: 2/4/2026
PROJECT DESCRIPTION: Roadway Cost					
CLIENT: City of Woods Cross					
J-U-B PROJ. NO.: 07-24-094					
No.	ITEM	QUANTITY	UNIT	UNIT COST	TOTAL COST
1050 S - 630 Feet					
2000 W to 1900 W					
17	Mobilization - 10%	1	LS	\$95,901.28	\$95,901.28
18	Storm Water Pollution Prevention	1	LS	\$6,300.00	\$6,300.00
19	Traffic Control - 10%	1	LS	\$95,901.28	\$95,901.28
20	Clear and Grub	1	LS	\$5,040.00	\$5,040.00
21	Dust Control & Watering	1	LS	\$2,205.00	\$2,205.00
22	Survey - 3%	1	LS	\$28,770.39	\$28,770.39
23	Drainage Pipes and System	1	LS	\$151,200.00	\$151,200.00
24	Roadway Excavation (Plan Quantity)	15,777	CY	\$25.00	\$394,430.56
25	Concrete Curb and Gutter	3,150	LF	\$28.00	\$88,200.00
26	HMA 6"	956	TON	\$150.00	\$143,356.50
27	Untreated Based Course 10"	1,089	CY	\$32.00	\$34,844.44
28	Granular Sub Base 12"	1,073	CY	\$28.00	\$30,053.33
29	Concrete Sidewalk	6,300	SF	\$15.00	\$94,500.00
30	4" Paint Line	2,520	LF	\$1.00	\$2,520.00
31	Sod	7,560	SF	\$1.30	\$9,828.00
32	Topsoil-6 inch thick	840	SY	\$12.00	\$10,080.00
				SUBTOTAL	\$1,193,130.79
				ROW Acquisition	\$0.00
				Contingency - 35%	\$417,595.77
				Design Engineering - 10%	\$119,313.08
				Construction Engineering - 10%	\$119,313.08
				Miscellaneous Item - 5%	\$59,656.54
Total:					\$1,909,100.00

 ENGINEER'S OPINION OF PROBABLE COST					
PROJECT NAME: Woods Cross TMP					DATE: 2/4/2026
PROJECT DESCRIPTION: Roadway Cost					
CLIENT: City of Woods Cross					
J-U-B PROJ. NO.: 07-24-094					
No.	ITEM	QUANTITY	UNIT	UNIT COST	TOTAL COST
1050 S - 710 Feet					
1900 W to Redwood Rd					
33	Mobilization - 10%	1	LS	\$108,079.22	\$108,079.22
34	Storm Water Pollution Prevention	1	LS	\$7,100.00	\$7,100.00
35	Traffic Control - 10%	1	LS	\$108,079.22	\$108,079.22
36	Clear and Grub	1	LS	\$5,680.00	\$5,680.00
37	Dust Control & Watering	1	LS	\$2,485.00	\$2,485.00
38	Survey - 3%	1	LS	\$32,423.77	\$32,423.77
39	Drainage Pipes and System	1	LS	\$170,400.00	\$170,400.00
40	Roadway Excavation (Plan Quantity)	17,781	CY	\$25.00	\$444,516.98
41	Concrete Curb and Gutter	3,550	LF	\$28.00	\$99,400.00
42	HMA 6"	1,077	TON	\$150.00	\$161,560.50
43	Untreated Based Course 10"	1,227	CY	\$32.00	\$39,269.14
44	Granular Sub Base 12"	1,210	CY	\$28.00	\$33,869.63
45	Concrete Sidewalk	7,100	SF	\$15.00	\$106,500.00
46	4" Paint Line	2,840	LF	\$1.00	\$2,840.00
47	Sod	8,520	SF	\$1.30	\$11,076.00
48	Topsoil-6 inch thick	947	SY	\$12.00	\$11,360.00
				SUBTOTAL	\$1,344,639.46
				ROW Acquisition	\$0.00
				Contingency - 35%	\$470,623.81
				Design Engineering - 10%	\$134,463.95
				Construction Engineering - 10%	\$134,463.95
				Miscellaneous Item - 5%	\$67,231.97
Total:					\$2,151,500.00

 ENGINEER'S OPINION OF PROBABLE COST					
PROJECT NAME: Woods Cross TMP					DATE: 2/4/2026
PROJECT DESCRIPTION: Roadway Cost					
CLIENT: City of Woods Cross					
J-U-B PROJ. NO.: 07-24-094					
No.	ITEM	QUANTITY	UNIT	UNIT COST	TOTAL COST
1050 S - 660 Feet					
Redwood Rd to 1650 W					
49	Mobilization - 10%	1	LS	\$100,468.01	\$100,468.01
50	Storm Water Pollution Prevention	1	LS	\$6,600.00	\$6,600.00
51	Traffic Control - 10%	1	LS	\$100,468.01	\$100,468.01
52	Clear and Grub	1	LS	\$5,280.00	\$5,280.00
53	Dust Control & Watering	1	LS	\$2,310.00	\$2,310.00
54	Survey - 3%	1	LS	\$30,140.40	\$30,140.40
55	Utilities (Contingency)	1	LS	\$50,234.01	\$50,234.01
56	Drainage Pipes and System	1	LS	\$158,400.00	\$158,400.00
57	Roadway Excavation (Plan Quantity)	16,529	CY	\$25.00	\$413,212.96
58	Concrete Curb and Gutter	3,300	LF	\$28.00	\$92,400.00
59	HMA 6"	1,001	TON	\$150.00	\$150,183.00
60	Untreated Based Course 10"	1,141	CY	\$32.00	\$36,503.70
61	Granular Sub Base 12"	1,124	CY	\$28.00	\$31,484.44
62	Concrete Sidewalk	6,600	SF	\$15.00	\$99,000.00
63	4" Paint Line	2,640	LF	\$1.00	\$2,640.00
64	Sod	7,920	SF	\$1.30	\$10,296.00
65	Topsoil-6 inch thick	880	SY	\$12.00	\$10,560.00
SUBTOTAL					\$1,300,180.54
ROW Acquisition					\$0.00
Contingency - 35%					\$455,063.19
Design Engineering - 10%					\$130,018.05
Construction Engineering - 10%					\$130,018.05
Miscellaneous Item - 5%					\$65,009.03
Total:					\$2,080,300.00

 ENGINEER'S OPINION OF PROBABLE COST					
PROJECT NAME: Woods Cross TMP					DATE: 2/4/2026
PROJECT DESCRIPTION: Roadway Cost					
CLIENT: City of Woods Cross					
J-U-B PROJ. NO.: 07-24-094					
No.	ITEM	QUANTITY	UNIT	UNIT COST	TOTAL COST
1050 S - 530 Feet					
1650 W to 1600 W					
66	Mobilization - 10%	1	LS	\$80,678.86	\$80,678.86
67	Storm Water Pollution Prevention	1	LS	\$5,300.00	\$5,300.00
68	Traffic Control - 10%	1	LS	\$80,678.86	\$80,678.86
69	Clear and Grub	1	LS	\$4,240.00	\$4,240.00
70	Dust Control & Watering	1	LS	\$1,855.00	\$1,855.00
71	Survey - 3%	1	LS	\$24,203.66	\$24,203.66
72	Utilities (Contingency)	1	LS	\$40,339.43	\$40,339.43
73	Drainage Pipes and System	1	LS	\$127,200.00	\$127,200.00
74	Roadway Excavation (Plan Quantity)	13,273	CY	\$25.00	\$331,822.53
75	Concrete Curb and Gutter	2,650	LF	\$28.00	\$74,200.00
76	HMA 6"	804	TON	\$150.00	\$120,601.50
77	Untreated Based Course 10"	916	CY	\$32.00	\$29,313.58
78	Granular Sub Base 12"	903	CY	\$28.00	\$25,282.96
79	Concrete Sidewalk	5,300	SF	\$15.00	\$79,500.00
80	4" Paint Line	2,120	LF	\$1.00	\$2,120.00
81	Sod	6,360	SF	\$1.30	\$8,268.00
82	Topsoil-6 inch thick	707	SY	\$12.00	\$8,480.00
SUBTOTAL					\$1,044,084.37
ROW Acquisition					\$0.00
Contingency - 35%					\$365,429.53
Design Engineering - 10%					\$104,408.44
Construction Engineering - 10%					\$104,408.44
Miscellaneous Item - 5%					\$52,204.22
Total:					\$1,670,600.00

 ENGINEER'S OPINION OF PROBABLE COST					
PROJECT NAME: Woods Cross TMP					DATE: 2/4/2026
PROJECT DESCRIPTION: Roadway Cost					
CLIENT: City of Woods Cross					
J-U-B PROJ. NO.: 07-24-094					
No.	ITEM	QUANTITY	UNIT	UNIT COST	TOTAL COST
1600 W - 320 Feet					
400 S to 500 S					
1	Mobilization - 10%	1	LS	\$48,711.76	\$48,711.76
2	Storm Water Pollution Prevention	1	LS	\$3,200.00	\$3,200.00
3	Traffic Control - 10%	1	LS	\$48,711.76	\$48,711.76
4	Clear and Grub	1	LS	\$2,560.00	\$2,560.00
5	Dust Control & Watering	1	LS	\$1,120.00	\$1,120.00
6	Survey - 3%	1	LS	\$14,613.53	\$14,613.53
7	Drainage Pipes and System	1	LS	\$76,800.00	\$76,800.00
8	Roadway Excavation (Plan Quantity)	8,014	CY	\$25.00	\$200,345.68
9	Concrete Curb and Gutter	1,600	LF	\$28.00	\$44,800.00
10	HMA 6"	485	TON	\$150.00	\$72,816.00
11	Untreated Based Course 10"	553	CY	\$32.00	\$17,698.77
12	Granular Sub Base 12"	545	CY	\$28.00	\$15,265.19
13	Concrete Sidewalk	3,200	SF	\$15.00	\$48,000.00
14	4" Paint Line	1,280	LF	\$1.00	\$1,280.00
15	Sod	3,840	SF	\$1.30	\$4,992.00
16	Topsoil-6 inch thick	427	SY	\$12.00	\$5,120.00
				SUBTOTAL	\$606,034.68
				ROW Acquisition	\$0.00
				Contingency - 35%	\$212,112.14
				Design Engineering - 10%	\$60,603.47
				Construction Engineering - 10%	\$60,603.47
				Miscellaneous Item - 5%	\$30,301.73
				Total:	\$969,700.00

 ENGINEER'S OPINION OF PROBABLE COST					
PROJECT NAME: Woods Cross TMP					DATE: 2/4/2026
PROJECT DESCRIPTION: Roadway Cost					
CLIENT: City of Woods Cross					
J-U-B PROJ. NO.: 07-24-094					
No.	ITEM	QUANTITY	UNIT	UNIT COST	TOTAL COST
1600 W - 990 Feet					
500 S to 750 S					
17	Mobilization - 10%	1	LS	\$150,702.02	\$150,702.02
18	Storm Water Pollution Prevention	1	LS	\$9,900.00	\$9,900.00
19	Traffic Control - 10%	1	LS	\$150,702.02	\$150,702.02
20	Clear and Grub	1	LS	\$7,920.00	\$7,920.00
21	Dust Control & Watering	1	LS	\$3,465.00	\$3,465.00
22	Survey - 3%	1	LS	\$45,210.61	\$45,210.61
23	Drainage Pipes and System	1	LS	\$237,600.00	\$237,600.00
24	Roadway Excavation (Plan Quantity)	24,793	CY	\$25.00	\$619,819.44
25	Concrete Curb and Gutter	4,950	LF	\$28.00	\$138,600.00
26	HMA 6"	1,502	TON	\$150.00	\$225,274.50
27	Untreated Based Course 10"	1,711	CY	\$32.00	\$54,755.56
28	Granular Sub Base 12"	1,687	CY	\$28.00	\$47,226.67
29	Concrete Sidewalk	9,900	SF	\$15.00	\$148,500.00
30	4" Paint Line	3,960	LF	\$1.00	\$3,960.00
31	Sod	11,880	SF	\$1.30	\$15,444.00
32	Topsoil-6 inch thick	1,320	SY	\$12.00	\$15,840.00
				SUBTOTAL	\$1,874,919.81
				ROW Acquisition	\$0.00
				Contingency - 35%	\$656,221.93
				Design Engineering - 10%	\$187,491.98
				Construction Engineering - 10%	\$187,491.98
				Miscellaneous Item - 5%	\$93,745.99
Total:					\$2,999,900.00

 ENGINEER'S OPINION OF PROBABLE COST					
PROJECT NAME: Woods Cross TMP					DATE: 2/4/2026
PROJECT DESCRIPTION: Roadway Cost					
CLIENT: City of Woods Cross					
J-U-B PROJ. NO.: 07-24-094					
No.	ITEM	QUANTITY	UNIT	UNIT COST	TOTAL COST
1600 W - 460 Feet					
750 S to 900 S					
33	Mobilization - 10%	1	LS	\$70,023.16	\$70,023.16
34	Storm Water Pollution Prevention	1	LS	\$4,600.00	\$4,600.00
35	Traffic Control - 10%	1	LS	\$70,023.16	\$70,023.16
36	Clear and Grub	1	LS	\$3,680.00	\$3,680.00
37	Dust Control & Watering	1	LS	\$1,610.00	\$1,610.00
38	Survey - 3%	1	LS	\$21,006.95	\$21,006.95
39	Drainage Pipes and System	1	LS	\$110,400.00	\$110,400.00
40	Roadway Excavation (Plan Quantity)	11,520	CY	\$25.00	\$287,996.91
41	Concrete Curb and Gutter	2,300	LF	\$28.00	\$64,400.00
42	HMA 6"	698	TON	\$150.00	\$104,673.00
43	Untreated Based Course 10"	795	CY	\$32.00	\$25,441.98
44	Granular Sub Base 12"	784	CY	\$28.00	\$21,943.70
45	Concrete Sidewalk	4,600	SF	\$15.00	\$69,000.00
46	4" Paint Line	1,840	LF	\$1.00	\$1,840.00
47	Sod	5,520	SF	\$1.30	\$7,176.00
48	Topsoil-6 inch thick	613	SY	\$12.00	\$7,360.00
				SUBTOTAL	\$871,174.86
				ROW Acquisition	\$0.00
				Contingency - 35%	\$304,911.20
				Design Engineering - 10%	\$87,117.49
				Construction Engineering - 10%	\$87,117.49
				Miscellaneous Item - 5%	\$43,558.74
Total:					\$1,393,900.00

ENGINEER'S OPINION OF PROBABLE COST					
 J-U-B ENGINEERS, INC.					
PROJECT NAME: Woods Cross TMP				DATE: 2/4/2026	
PROJECT DESCRIPTION: Roadway Cost					
CLIENT: City of Woods Cross					
J-U-B PROJ. NO.: 07-24-094					
No.	ITEM	QUANTITY	UNIT	UNIT COST	TOTAL COST
1600 W - 550 Feet					
900 S to 1050 S					
49	Mobilization - 10%	1	LS	\$83,723.34	\$83,723.34
50	Storm Water Pollution Prevention	1	LS	\$5,500.00	\$5,500.00
51	Traffic Control - 10%	1	LS	\$83,723.34	\$83,723.34
52	Clear and Grub	1	LS	\$4,400.00	\$4,400.00
53	Dust Control & Watering	1	LS	\$1,925.00	\$1,925.00
54	Survey - 3%	1	LS	\$25,117.00	\$25,117.00
55	Utilities (Contingency)	1	LS	\$41,861.67	\$41,861.67
56	Drainage Pipes and System	1	LS	\$132,000.00	\$132,000.00
57	Roadway Excavation (Plan Quantity)	13,774	CY	\$25.00	\$344,344.14
58	Concrete Curb and Gutter	2,750	LF	\$28.00	\$77,000.00
59	HMA 6"	834	TON	\$150.00	\$125,152.50
60	Untreated Based Course 10"	951	CY	\$32.00	\$30,419.75
61	Granular Sub Base 12"	937	CY	\$28.00	\$26,237.04
62	Concrete Sidewalk	5,500	SF	\$15.00	\$82,500.00
63	4" Paint Line	2,200	LF	\$1.00	\$2,200.00
64	Sod	6,600	SF	\$1.30	\$8,580.00
65	Topsoil-6 inch thick	733	SY	\$12.00	\$8,800.00
				SUBTOTAL	\$1,083,483.79
				ROW Acquisition	\$0.00
				Contingency - 35%	\$379,219.32
				Design Engineering - 10%	\$108,348.38
				Construction Engineering - 10%	\$108,348.38
				Miscellaneous Item - 5%	\$54,174.19
Total:					\$1,733,600.00

ENGINEER'S OPINION OF PROBABLE COST					
					
J-U-B ENGINEERS, INC.					
PROJECT NAME: Woods Cross TMP				DATE: 2/4/2026	
PROJECT DESCRIPTION: Roadway Cost					
CLIENT: City of Woods Cross					
J-U-B PROJ. NO.: 07-24-094					
No.	ITEM	QUANTITY	UNIT	UNIT COST	TOTAL COST
1600 W - 155 Feet					
1050 S to 1115 S					
66	Mobilization - 10%	1	LS	\$23,594.76	\$23,594.76
67	Storm Water Pollution Prevention	1	LS	\$1,550.00	\$1,550.00
68	Traffic Control - 10%	1	LS	\$23,594.76	\$23,594.76
69	Clear and Grub	1	LS	\$1,240.00	\$1,240.00
70	Dust Control & Watering	1	LS	\$542.50	\$542.50
71	Survey - 3%	1	LS	\$7,078.43	\$7,078.43
72	Utilities (Contingency)	1	LS	\$11,797.38	\$11,797.38
73	Drainage Pipes and System	1	LS	\$37,200.00	\$37,200.00
74	Roadway Excavation (Plan Quantity)	3,882	CY	\$25.00	\$97,042.44
75	Concrete Curb and Gutter	775	LF	\$28.00	\$21,700.00
76	HMA 6"	235	TON	\$150.00	\$35,270.25
77	Untreated Based Course 10"	268	CY	\$32.00	\$8,572.84
78	Granular Sub Base 12"	264	CY	\$28.00	\$7,394.07
79	Concrete Sidewalk	1,550	SF	\$15.00	\$23,250.00
80	4" Paint Line	620	LF	\$1.00	\$620.00
81	Sod	1,860	SF	\$1.30	\$2,418.00
82	Topsoil-6 inch thick	207	SY	\$12.00	\$2,480.00
				SUBTOTAL	\$305,345.43
				ROW Acquisition	\$0.00
				Contingency - 35%	\$106,870.90
				Design Engineering - 10%	\$30,534.54
				Construction Engineering - 10%	\$30,534.54
				Miscellaneous Item - 5%	\$15,267.27
Total:					\$488,600.00

 ENGINEER'S OPINION OF PROBABLE COST					
PROJECT NAME: Woods Cross TMP					DATE: 2/4/2026
PROJECT DESCRIPTION: Roadway Cost					
CLIENT: City of Woods Cross					
J-U-B PROJ. NO.: 07-24-094					
No.	ITEM	QUANTITY	UNIT	UNIT COST	TOTAL COST
1600 W - 220 Feet					
1115 S to 1180 S					
83	Mobilization - 10%	1	LS	\$33,489.34	\$33,489.34
84	Storm Water Pollution Prevention	1	LS	\$2,200.00	\$2,200.00
85	Traffic Control - 10%	1	LS	\$33,489.34	\$33,489.34
86	Clear and Grub	1	LS	\$1,760.00	\$1,760.00
87	Dust Control & Watering	1	LS	\$770.00	\$770.00
88	Survey - 3%	1	LS	\$10,046.80	\$10,046.80
89	Utilities (Contingency)	1	LS	\$16,744.67	\$16,744.67
90	Drainage Pipes and System	1	LS	\$52,800.00	\$52,800.00
91	Roadway Excavation (Plan Quantity)	5,510	CY	\$25.00	\$137,737.65
92	Concrete Curb and Gutter	1,100	LF	\$28.00	\$30,800.00
93	HMA 6"	334	TON	\$150.00	\$50,061.00
94	Untreated Based Course 10"	380	CY	\$32.00	\$12,167.90
95	Granular Sub Base 12"	375	CY	\$28.00	\$10,494.81
96	Concrete Sidewalk	2,200	SF	\$15.00	\$33,000.00
97	4" Paint Line	880	LF	\$1.00	\$880.00
98	Sod	2,640	SF	\$1.30	\$3,432.00
99	Topsoil-6 inch thick	293	SY	\$12.00	\$3,520.00
				SUBTOTAL	\$433,393.51
				ROW Acquisition	\$0.00
				Contingency - 35%	\$151,687.73
				Design Engineering - 10%	\$43,339.35
				Construction Engineering - 10%	\$43,339.35
				Miscellaneous Item - 5%	\$21,669.68
Total:					\$693,500.00

 ENGINEER'S OPINION OF PROBABLE COST					
PROJECT NAME: Woods Cross TMP					DATE: 2/4/2026
PROJECT DESCRIPTION: Roadway Cost					
CLIENT: City of Woods Cross					
J-U-B PROJ. NO.: 07-24-094					
No.	ITEM	QUANTITY	UNIT	UNIT COST	TOTAL COST
1600 W - 1050 Feet					
1180 S to 1500 S					
100	Mobilization - 10%	1	LS	\$159,835.47	\$159,835.47
101	Storm Water Pollution Prevention	1	LS	\$10,500.00	\$10,500.00
102	Traffic Control - 10%	1	LS	\$159,835.47	\$159,835.47
103	Clear and Grub	1	LS	\$8,400.00	\$8,400.00
104	Dust Control & Watering	1	LS	\$3,675.00	\$3,675.00
105	Survey - 3%	1	LS	\$47,950.64	\$47,950.64
106	Utilities (Contingency)	1	LS	\$79,917.74	\$79,917.74
107	Drainage Pipes and System	1	LS	\$252,000.00	\$252,000.00
108	Roadway Excavation (Plan Quantity)	26,295	CY	\$25.00	\$657,384.26
109	Concrete Curb and Gutter	5,250	LF	\$28.00	\$147,000.00
110	HMA 6"	1,593	TON	\$150.00	\$238,927.50
111	Untreated Based Course 10"	1,815	CY	\$32.00	\$58,074.07
112	Granular Sub Base 12"	1,789	CY	\$28.00	\$50,088.89
113	Concrete Sidewalk	10,500	SF	\$15.00	\$157,500.00
114	4" Paint Line	4,200	LF	\$1.00	\$4,200.00
115	Sod	12,600	SF	\$1.30	\$16,380.00
116	Topsoil-6 inch thick	1,400	SY	\$12.00	\$16,800.00
SUBTOTAL					\$2,068,469.04
ROW Acquisition					\$0.00
Contingency - 35%					\$723,964.17
Design Engineering - 10%					\$206,846.90
Construction Engineering - 10%					\$206,846.90
Miscellaneous Item - 5%					\$103,423.45
Total:					\$3,309,600.00

 ENGINEER'S OPINION OF PROBABLE COST					
PROJECT NAME: Woods Cross TMP					DATE: 2/4/2026
PROJECT DESCRIPTION: Roadway Cost					
CLIENT: City of Woods Cross					
J-U-B PROJ. NO.: 07-24-094					
No.	ITEM	QUANTITY	UNIT	UNIT COST	TOTAL COST
1450 W - 990 Feet					
500 S to 750 S					
1	Mobilization - 10%	1	LS	\$150,702.02	\$150,702.02
2	Storm Water Pollution Prevention	1	LS	\$9,900.00	\$9,900.00
3	Traffic Control - 10%	1	LS	\$150,702.02	\$150,702.02
4	Clear and Grub	1	LS	\$7,920.00	\$7,920.00
5	Dust Control & Watering	1	LS	\$3,465.00	\$3,465.00
6	Survey - 3%	1	LS	\$45,210.61	\$45,210.61
7	Drainage Pipes and System	1	LS	\$237,600.00	\$237,600.00
8	Roadway Excavation (Plan Quantity)	24,793	CY	\$25.00	\$619,819.44
9	Concrete Curb and Gutter	4,950	LF	\$28.00	\$138,600.00
10	HMA 6"	1,502	TON	\$150.00	\$225,274.50
11	Untreated Based Course 10"	1,711	CY	\$32.00	\$54,755.56
12	Granular Sub Base 12"	1,687	CY	\$28.00	\$47,226.67
13	Concrete Sidewalk	9,900	SF	\$15.00	\$148,500.00
14	4" Paint Line	3,960	LF	\$1.00	\$3,960.00
15	Sod	11,880	SF	\$1.30	\$15,444.00
16	Topsoil-6 inch thick	1,320	SY	\$12.00	\$15,840.00
				SUBTOTAL	\$1,874,919.81
				ROW Acquisition	\$0.00
				Contingency - 35%	\$656,221.93
				Design Engineering - 10%	\$187,491.98
				Construction Engineering - 10%	\$187,491.98
				Miscellaneous Item - 5%	\$93,745.99
Total:					\$2,999,900.00

 ENGINEER'S OPINION OF PROBABLE COST					
PROJECT NAME: Woods Cross TMP					DATE: 2/4/2026
PROJECT DESCRIPTION: Roadway Cost					
CLIENT: City of Woods Cross					
J-U-B PROJ. NO.: 07-24-094					
No.	ITEM	QUANTITY	UNIT	UNIT COST	TOTAL COST
1450 W - 1370 Feet					
750 S to 1200 S					
17	Mobilization - 10%	1	LS	\$208,547.24	\$208,547.24
18	Storm Water Pollution Prevention	1	LS	\$13,700.00	\$13,700.00
19	Traffic Control - 10%	1	LS	\$208,547.24	\$208,547.24
20	Clear and Grub	1	LS	\$10,960.00	\$10,960.00
21	Dust Control & Watering	1	LS	\$4,795.00	\$4,795.00
22	Survey - 3%	1	LS	\$62,564.17	\$62,564.17
23	Drainage Pipes and System	1	LS	\$328,800.00	\$328,800.00
24	Roadway Excavation (Plan Quantity)	34,309	CY	\$25.00	\$857,729.94
25	Concrete Curb and Gutter	6,850	LF	\$28.00	\$191,800.00
26	HMA 6"	2,078	TON	\$150.00	\$311,743.50
27	Untreated Based Course 10"	2,368	CY	\$32.00	\$75,772.84
28	Granular Sub Base 12"	2,334	CY	\$28.00	\$65,354.07
29	Concrete Sidewalk	13,700	SF	\$15.00	\$205,500.00
30	4" Paint Line	5,480	LF	\$1.00	\$5,480.00
31	Sod	16,440	SF	\$1.30	\$21,372.00
32	Topsoil-6 inch thick	1,827	SY	\$12.00	\$21,920.00
				SUBTOTAL	\$2,594,585.99
				ROW Acquisition	\$0.00
				Contingency - 35%	\$908,105.10
				Design Engineering - 10%	\$259,458.60
				Construction Engineering - 10%	\$259,458.60
				Miscellaneous Item - 5%	\$129,729.30
Total:					\$4,151,400.00

 ENGINEER'S OPINION OF PROBABLE COST					
PROJECT NAME: Woods Cross TMP					DATE: 2/4/2026
PROJECT DESCRIPTION: Roadway Cost					
CLIENT: City of Woods Cross					
J-U-B PROJ. NO.: 07-24-094					
No.	ITEM	QUANTITY	UNIT	UNIT COST	TOTAL COST
1450 W - 1120 Feet					
1200 S to 1500 S					
33	Mobilization - 10%	1	LS	\$186,047.84	\$186,047.84
34	Storm Water Pollution Prevention	1	LS	\$11,200.00	\$11,200.00
35	Traffic Control - 10%	1	LS	\$186,047.84	\$186,047.84
36	Clear and Grub	1	LS	\$8,960.00	\$8,960.00
37	Dust Control & Watering	1	LS	\$3,920.00	\$3,920.00
38	Survey - 3%	1	LS	\$55,814.35	\$55,814.35
39	Drainage Pipes and System	1	LS	\$268,800.00	\$268,800.00
40	Relocate Street Light	3	EA	\$1,500.00	\$4,500.00
41	Roadway Excavation (Plan Quantity)	28,048	CY	\$25.00	\$701,209.88
42	Remove Asphalt Pavement	3,733	SY	\$6.50	\$24,266.67
43	Relocate Sign	4	EA	\$200.00	\$800.00
44	Concrete Curb and Gutter	5,600	LF	\$28.00	\$156,800.00
45	HMA 6"	1,699	TON	\$150.00	\$254,856.00
46	Untreated Based Course 10"	1,936	CY	\$32.00	\$61,945.68
47	Granular Sub Base 12"	1,908	CY	\$28.00	\$53,428.15
48	Concrete Driveway	5,250	SF	\$20.00	\$105,000.00
49	Concrete Sidewalk	11,200	SF	\$15.00	\$168,000.00
50	Concrete Curb Ramp	6	EA	\$3,500.00	\$21,000.00
51	4" Paint Line	4,480	LF	\$1.00	\$4,480.00
52	Sod	13,440	SF	\$1.30	\$17,472.00
53	Topsoil-6 inch thick	1,493	SY	\$12.00	\$17,920.00
				SUBTOTAL	\$2,312,468.40
				ROW Acquisition	\$0.00
				Contingency - 35%	\$809,363.94
				Design Engineering - 10%	\$231,246.84
				Construction Engineering - 10%	\$231,246.84
				Miscellaneous Item - 5%	\$115,623.42
Total:					\$3,700,000.00

 ENGINEER'S OPINION OF PROBABLE COST					
PROJECT NAME: Woods Cross TMP					DATE: 2/4/2026
PROJECT DESCRIPTION: Roadway Cost					
CLIENT: City of Woods Cross					
J-U-B PROJ. NO.: 07-24-094					
No.	ITEM	QUANTITY	UNIT	UNIT COST	TOTAL COST
Mountain View Blvd - 460 Feet					
750 S to 900 S					
1	Mobilization - 10%	1	LS	\$70,023.16	\$70,023.16
2	Storm Water Pollution Prevention	1	LS	\$4,600.00	\$4,600.00
3	Traffic Control - 10%	1	LS	\$70,023.16	\$70,023.16
4	Clear and Grub	1	LS	\$3,680.00	\$3,680.00
5	Dust Control & Watering	1	LS	\$1,610.00	\$1,610.00
6	Survey - 3%	1	LS	\$21,006.95	\$21,006.95
7	Drainage Pipes and System	1	LS	\$110,400.00	\$110,400.00
8	Roadway Excavation (Plan Quantity)	11,520	CY	\$25.00	\$287,996.91
9	Concrete Curb and Gutter	2,300	LF	\$28.00	\$64,400.00
10	HMA 6"	698	TON	\$150.00	\$104,673.00
11	Untreated Based Course 10"	795	CY	\$32.00	\$25,441.98
12	Granular Sub Base 12"	784	CY	\$28.00	\$21,943.70
13	Concrete Sidewalk	4,600	SF	\$15.00	\$69,000.00
14	4" Paint Line	1,840	LF	\$1.00	\$1,840.00
15	Sod	5,520	SF	\$1.30	\$7,176.00
16	Topsoil-6 inch thick	613	SY	\$12.00	\$7,360.00
				SUBTOTAL	\$871,174.86
				ROW Acquisition	\$0.00
				Contingency - 35%	\$304,911.20
				Design Engineering - 10%	\$87,117.49
				Construction Engineering - 10%	\$87,117.49
				Miscellaneous Item - 5%	\$43,558.74
Total:					\$1,393,900.00

 ENGINEER'S OPINION OF PROBABLE COST					
PROJECT NAME: Woods Cross TMP					DATE: 2/4/2026
PROJECT DESCRIPTION: Roadway Cost					
CLIENT: City of Woods Cross					
J-U-B PROJ. NO.: 07-24-094					
No.	ITEM	QUANTITY	UNIT	UNIT COST	TOTAL COST
Mountain View Blvd - 550 Feet					
900 S to 1050 S					
17	Mobilization - 10%	1	LS	\$83,723.34	\$83,723.34
18	Storm Water Pollution Prevention	1	LS	\$5,500.00	\$5,500.00
19	Traffic Control - 10%	1	LS	\$83,723.34	\$83,723.34
20	Clear and Grub	1	LS	\$4,400.00	\$4,400.00
21	Dust Control & Watering	1	LS	\$1,925.00	\$1,925.00
22	Survey - 3%	1	LS	\$25,117.00	\$25,117.00
23	Drainage Pipes and System	1	LS	\$132,000.00	\$132,000.00
24	Roadway Excavation (Plan Quantity)	13,774	CY	\$25.00	\$344,344.14
25	Concrete Curb and Gutter	2,750	LF	\$28.00	\$77,000.00
26	HMA 6"	834	TON	\$150.00	\$125,152.50
27	Untreated Based Course 10"	951	CY	\$32.00	\$30,419.75
28	Granular Sub Base 12"	937	CY	\$28.00	\$26,237.04
29	Concrete Sidewalk	5,500	SF	\$15.00	\$82,500.00
30	4" Paint Line	2,200	LF	\$1.00	\$2,200.00
31	Sod	6,600	SF	\$1.30	\$8,580.00
32	Topsoil-6 inch thick	733	SY	\$12.00	\$8,800.00
				SUBTOTAL	\$1,041,622.11
				ROW Acquisition	\$0.00
				Contingency - 35%	\$364,567.74
				Design Engineering - 10%	\$104,162.21
				Construction Engineering - 10%	\$104,162.21
				Miscellaneous Item - 5%	\$52,081.11
Total:					\$1,666,600.00

 ENGINEER'S OPINION OF PROBABLE COST					
PROJECT NAME: Woods Cross TMP					DATE: 2/4/2026
PROJECT DESCRIPTION: Roadway Cost					
CLIENT: City of Woods Cross					
J-U-B PROJ. NO.: 07-24-094					
No.	ITEM	QUANTITY	UNIT	UNIT COST	TOTAL COST
Mountain View Blvd - 155 Feet					
1050 S to 1115 S					
33	Mobilization - 10%	1	LS	\$23,594.76	\$23,594.76
34	Storm Water Pollution Prevention	1	LS	\$1,550.00	\$1,550.00
35	Traffic Control - 10%	1	LS	\$23,594.76	\$23,594.76
36	Clear and Grub	1	LS	\$1,240.00	\$1,240.00
37	Dust Control & Watering	1	LS	\$542.50	\$542.50
38	Survey - 3%	1	LS	\$7,078.43	\$7,078.43
39	Drainage Pipes and System	1	LS	\$37,200.00	\$37,200.00
40	Roadway Excavation (Plan Quantity)	3,882	CY	\$25.00	\$97,042.44
41	Concrete Curb and Gutter	775	LF	\$28.00	\$21,700.00
42	HMA 6"	235	TON	\$150.00	\$35,270.25
43	Untreated Based Course 10"	268	CY	\$32.00	\$8,572.84
44	Granular Sub Base 12"	264	CY	\$28.00	\$7,394.07
45	Concrete Sidewalk	1,550	SF	\$15.00	\$23,250.00
46	4" Paint Line	620	LF	\$1.00	\$620.00
47	Sod	1,860	SF	\$1.30	\$2,418.00
48	Topsoil-6 inch thick	207	SY	\$12.00	\$2,480.00
				SUBTOTAL	\$293,548.05
				ROW Acquisition	\$0.00
				Contingency - 35%	\$102,741.82
				Design Engineering - 10%	\$29,354.81
				Construction Engineering - 10%	\$29,354.81
				Miscellaneous Item - 5%	\$14,677.40
				Total:	\$469,700.00

 ENGINEER'S OPINION OF PROBABLE COST					
PROJECT NAME: Woods Cross TMP					DATE: 2/4/2026
PROJECT DESCRIPTION: Roadway Cost					
CLIENT: City of Woods Cross					
J-U-B PROJ. NO.: 07-24-094					
No.	ITEM	QUANTITY	UNIT	UNIT COST	TOTAL COST
Mountain View Blvd - 220 Feet					
1115 S to 1180 S					
49	Mobilization - 10%	1	LS	\$33,489.34	\$33,489.34
50	Storm Water Pollution Prevention	1	LS	\$2,200.00	\$2,200.00
51	Traffic Control - 10%	1	LS	\$33,489.34	\$33,489.34
52	Clear and Grub	1	LS	\$1,760.00	\$1,760.00
53	Dust Control & Watering	1	LS	\$770.00	\$770.00
54	Survey - 3%	1	LS	\$10,046.80	\$10,046.80
55	Utilities (Contingency)	1	LS	\$16,744.67	\$16,744.67
56	Drainage Pipes and System	1	LS	\$52,800.00	\$52,800.00
57	Roadway Excavation (Plan Quantity)	5,510	CY	\$25.00	\$137,737.65
58	Concrete Curb and Gutter	1,100	LF	\$28.00	\$30,800.00
59	HMA 6"	334	TON	\$150.00	\$50,061.00
60	Untreated Based Course 10"	380	CY	\$32.00	\$12,167.90
61	Granular Sub Base 12"	375	CY	\$28.00	\$10,494.81
62	Concrete Sidewalk	2,200	SF	\$15.00	\$33,000.00
63	4" Paint Line	880	LF	\$1.00	\$880.00
64	Sod	2,640	SF	\$1.30	\$3,432.00
65	Topsoil-6 inch thick	293	SY	\$12.00	\$3,520.00
				SUBTOTAL	\$433,393.51
				ROW Acquisition	\$0.00
				Contingency - 35%	\$151,687.73
				Design Engineering - 10%	\$43,339.35
				Construction Engineering - 10%	\$43,339.35
				Miscellaneous Item - 5%	\$21,669.68
Total:					\$693,500.00

 ENGINEER'S OPINION OF PROBABLE COST					
PROJECT NAME: Woods Cross TMP					DATE: 2/4/2026
PROJECT DESCRIPTION: Roadway Cost					
CLIENT: City of Woods Cross					
J-U-B PROJ. NO.: 07-24-094					
No.	ITEM	QUANTITY	UNIT	UNIT COST	TOTAL COST
Mountain View Blvd - 625 Feet					
1180 S to 1400 S					
66	Mobilization - 10%	1	LS	\$95,140.16	\$95,140.16
67	Storm Water Pollution Prevention	1	LS	\$6,250.00	\$6,250.00
68	Traffic Control - 10%	1	LS	\$95,140.16	\$95,140.16
69	Clear and Grub	1	LS	\$5,000.00	\$5,000.00
70	Dust Control & Watering	1	LS	\$2,187.50	\$2,187.50
71	Survey - 3%	1	LS	\$28,542.05	\$28,542.05
72	Utilities (Contingency)	1	LS	\$47,570.08	\$47,570.08
73	Drainage Pipes and System	1	LS	\$150,000.00	\$150,000.00
74	Roadway Excavation (Plan Quantity)	15,652	CY	\$25.00	\$391,300.15
75	Concrete Curb and Gutter	3,125	LF	\$28.00	\$87,500.00
76	HMA 6"	948	TON	\$150.00	\$142,218.75
77	Untreated Based Course 10"	1,080	CY	\$32.00	\$34,567.90
78	Granular Sub Base 12"	1,065	CY	\$28.00	\$29,814.81
79	Concrete Sidewalk	6,250	SF	\$15.00	\$93,750.00
80	4" Paint Line	2,500	LF	\$1.00	\$2,500.00
81	Sod	7,500	SF	\$1.30	\$9,750.00
82	Topsoil-6 inch thick	833	SY	\$12.00	\$10,000.00
				SUBTOTAL	\$1,231,231.57
				ROW Acquisition	\$0.00
				Contingency - 35%	\$430,931.05
				Design Engineering - 10%	\$123,123.16
				Construction Engineering - 10%	\$123,123.16
				Miscellaneous Item - 5%	\$61,561.58
Total:					\$1,970,000.00

 ENGINEER'S OPINION OF PROBABLE COST					
PROJECT NAME:				DATE: 2/4/2026	
Woods Cross TMP					
PROJECT DESCRIPTION:					
Roadway Cost					
CLIENT:					
City of Woods Cross					
J-U-B PROJ. NO.: 07-24-094					
No.	ITEM	QUANTITY	UNIT	UNIT COST	TOTAL COST
Mountain View Blvd - 360 Feet					
1400 S to 1500 S					
83	Mobilization - 10%	1	LS	\$61,608.73	\$61,608.73
84	Storm Water Pollution Prevention	1	LS	\$3,600.00	\$3,600.00
85	Traffic Control - 10%	1	LS	\$61,608.73	\$61,608.73
86	Clear and Grub	1	LS	\$2,880.00	\$2,880.00
87	Dust Control & Watering	1	LS	\$1,260.00	\$1,260.00
88	Survey - 3%	1	LS	\$18,482.62	\$18,482.62
89	Utilities (Contingency)	1	LS	\$30,804.37	\$30,804.37
90	Drainage Pipes and System	1	LS	\$86,400.00	\$86,400.00
91	Relocate Street Light	3	EA	\$1,500.00	\$4,500.00
92	Roadway Excavation (Plan Quantity)	9,016	CY	\$25.00	\$225,388.89
93	Remove Asphalt Pavement	1,720	SY	\$6.50	\$11,180.00
94	Relocate Sign	2	EA	\$200.00	\$400.00
95	Concrete Curb and Gutter	1,800	LF	\$28.00	\$50,400.00
96	HMA 6"	546	TON	\$150.00	\$81,918.00
97	Untreated Based Course 10"	622	CY	\$32.00	\$19,911.11
98	Granular Sub Base 12"	613	CY	\$28.00	\$17,173.33
99	Concrete Driveway	2,250	SF	\$20.00	\$45,000.00
100	Concrete Sidewalk	3,600	SF	\$15.00	\$54,000.00
101	Concrete Curb Ramp	2	EA	\$3,500.00	\$7,000.00
102	4" Paint Line	1,440	LF	\$1.00	\$1,440.00
103	Sod	4,320	SF	\$1.30	\$5,616.00
104	Topsoil-6 inch thick	480	SY	\$12.00	\$5,760.00
				SUBTOTAL	\$796,331.79
				ROW Acquisition	\$0.00
				Contingency - 35%	\$278,716.13
				Design Engineering - 10%	\$79,633.18
				Construction Engineering - 10%	\$79,633.18
				Miscellaneous Item - 5%	\$39,816.59
Total:					\$1,274,200.00

 ENGINEER'S OPINION OF PROBABLE COST					
PROJECT NAME:				DATE: 2/4/2026	
Woods Cross TMP					
PROJECT DESCRIPTION:					
Roadway Cost					
CLIENT:					
City of Woods Cross					
J-U-B PROJ. NO.: 07-24-094					
No.	ITEM	QUANTITY	UNIT	UNIT COST	TOTAL COST
Mountain View Blvd - 440 Feet					
1500 S to 1690 S					
105	Mobilization - 10%	1	LS	\$73,318.67	\$73,318.67
106	Storm Water Pollution Prevention	1	LS	\$4,400.00	\$4,400.00
107	Traffic Control - 10%	1	LS	\$73,318.67	\$73,318.67
108	Clear and Grub	1	LS	\$3,520.00	\$3,520.00
109	Dust Control & Watering	1	LS	\$1,540.00	\$1,540.00
110	Survey - 3%	1	LS	\$21,995.60	\$21,995.60
111	Utilities (Contingency)	1	LS	\$36,659.34	\$36,659.34
112	Drainage Pipes and System	1	LS	\$105,600.00	\$105,600.00
113	Relocate Street Light	2	EA	\$1,500.00	\$3,000.00
114	Roadway Excavation (Plan Quantity)	11,019	CY	\$25.00	\$275,475.31
115	Remove Asphalt Pavement	2,200	SY	\$6.50	\$14,300.00
116	Relocate Sign	3	EA	\$200.00	\$600.00
117	Concrete Curb and Gutter	2,200	LF	\$28.00	\$61,600.00
118	HMA 6"	667	TON	\$150.00	\$100,122.00
119	Untreated Based Course 10"	760	CY	\$32.00	\$24,335.80
120	Granular Sub Base 12"	750	CY	\$28.00	\$20,989.63
121	Concrete Driveway	1,750	SF	\$20.00	\$35,000.00
122	Concrete Sidewalk	4,400	SF	\$15.00	\$66,000.00
123	Concrete Curb Ramp	3	EA	\$3,500.00	\$10,500.00
124	4" Paint Line	1,760	LF	\$1.00	\$1,760.00
125	Sod	5,280	SF	\$1.30	\$6,864.00
126	Topsoil-6 inch thick	587	SY	\$12.00	\$7,040.00
				SUBTOTAL	\$947,939.03
				ROW Acquisition	\$0.00
				Contingency - 35%	\$331,778.66
				Design Engineering - 10%	\$94,793.90
				Construction Engineering - 10%	\$94,793.90
				Miscellaneous Item - 5%	\$47,396.95
Total:					\$1,516,800.00

 ENGINEER'S OPINION OF PROBABLE COST					
PROJECT NAME: Woods Cross TMP		DATE: 2/4/2026			
PROJECT DESCRIPTION: Roadway Cost					
CLIENT: City of Woods Cross					
J-U-B PROJ. NO.: 07-24-094					
No.	ITEM	QUANTITY	UNIT	UNIT COST	TOTAL COST
Mountain View Blvd - 640 Feet					
1690 S to 1870 S					
127	Mobilization - 10%	1	LS	\$108,012.41	\$108,012.41
128	Storm Water Pollution Prevention	1	LS	\$6,400.00	\$6,400.00
129	Traffic Control - 10%	1	LS	\$108,012.41	\$108,012.41
130	Clear and Grub	1	LS	\$5,120.00	\$5,120.00
131	Dust Control & Watering	1	LS	\$2,240.00	\$2,240.00
132	Survey - 3%	1	LS	\$32,403.72	\$32,403.72
133	Utilities (Contingency)	1	LS	\$54,006.21	\$54,006.21
134	Drainage Pipes and System	1	LS	\$153,600.00	\$153,600.00
135	Relocate Street Light	2	EA	\$1,500.00	\$3,000.00
136	Roadway Excavation (Plan Quantity)	16,028	CY	\$25.00	\$400,691.36
137	Remove Asphalt Pavement	2,844	SY	\$6.50	\$18,488.89
138	Relocate Sign	2	EA	\$200.00	\$400.00
139	Concrete Curb and Gutter	3,200	LF	\$28.00	\$89,600.00
140	HMA 6"	971	TON	\$150.00	\$145,632.00
141	Untreated Based Course 10"	1,106	CY	\$32.00	\$35,397.53
142	Granular Sub Base 12"	1,090	CY	\$28.00	\$30,530.37
143	Concrete Driveway	3,500	SF	\$20.00	\$70,000.00
144	Concrete Sidewalk	6,400	SF	\$15.00	\$96,000.00
145	Concrete Curb Ramp	4	EA	\$3,500.00	\$14,000.00
146	4" Paint Line	2,560	LF	\$1.00	\$2,560.00
147	Sod	7,680	SF	\$1.30	\$9,984.00
148	Topsoil-6 inch thick	853	SY	\$12.00	\$10,240.00
				SUBTOTAL	\$1,396,318.91
				ROW Acquisition	\$0.00
				Contingency - 35%	\$488,711.62
				Design Engineering - 10%	\$139,631.89
				Construction Engineering - 10%	\$139,631.89
				Miscellaneous Item - 5%	\$69,815.95
Total:					\$2,234,200.00

 ENGINEER'S OPINION OF PROBABLE COST					
PROJECT NAME:				DATE: 2/4/2026	
Woods Cross TMP					
PROJECT DESCRIPTION:					
Roadway Cost					
CLIENT:					
City of Woods Cross					
J-U-B PROJ. NO.: 07-24-094					
No.	ITEM	QUANTITY	UNIT	UNIT COST	TOTAL COST
Mountain View Blvd - 440 Feet					
1870 S to 1990 S					
149	Mobilization - 10%	1	LS	\$72,215.12	\$72,215.12
150	Storm Water Pollution Prevention	1	LS	\$4,400.00	\$4,400.00
151	Traffic Control - 10%	1	LS	\$72,215.12	\$72,215.12
152	Clear and Grub	1	LS	\$3,520.00	\$3,520.00
153	Dust Control & Watering	1	LS	\$1,540.00	\$1,540.00
154	Survey - 3%	1	LS	\$21,664.54	\$21,664.54
155	Drainage Pipes and System	1	LS	\$105,600.00	\$105,600.00
156	Relocate Street Light	3	EA	\$1,500.00	\$4,500.00
157	Roadway Excavation (Plan Quantity)	11,019	CY	\$25.00	\$275,475.31
158	Remove Asphalt Pavement	2,102	SY	\$6.50	\$13,664.44
159	Relocate Sign	1	EA	\$200.00	\$200.00
160	Concrete Curb and Gutter	2,200	LF	\$28.00	\$61,600.00
161	HMA 6"	667	TON	\$150.00	\$100,122.00
162	Untreated Based Course 10"	760	CY	\$32.00	\$24,335.80
163	Granular Sub Base 12"	750	CY	\$28.00	\$20,989.63
164	Concrete Driveway	1,000	SF	\$20.00	\$20,000.00
165	Concrete Sidewalk	4,400	SF	\$15.00	\$66,000.00
166	Concrete Curb Ramp	4	EA	\$3,500.00	\$14,000.00
167	4" Paint Line	1,760	LF	\$1.00	\$1,760.00
168	Sod	5,280	SF	\$1.30	\$6,864.00
169	Topsoil-6 inch thick	587	SY	\$12.00	\$7,040.00
				SUBTOTAL	\$897,705.96
				ROW Acquisition	\$0.00
				Contingency - 35%	\$314,197.09
				Design Engineering - 10%	\$89,770.60
				Construction Engineering - 10%	\$89,770.60
				Miscellaneous Item - 5%	\$44,885.30
Total:					\$1,436,400.00

 ENGINEER'S OPINION OF PROBABLE COST					
PROJECT NAME: Woods Cross TMP				DATE: 2/4/2026	
PROJECT DESCRIPTION: Roadway Cost					
CLIENT: City of Woods Cross					
J-U-B PROJ. NO.: 07-24-094					
No.	ITEM	QUANTITY	UNIT	UNIT COST	TOTAL COST
Mountain View Blvd - 1080 Feet					
1990 S to 2170 S					
170	Mobilization - 10%	1	LS	\$182,012.20	\$182,012.20
171	Storm Water Pollution Prevention	1	LS	\$10,800.00	\$10,800.00
172	Traffic Control - 10%	1	LS	\$182,012.20	\$182,012.20
173	Clear and Grub	1	LS	\$8,640.00	\$8,640.00
174	Dust Control & Watering	1	LS	\$3,780.00	\$3,780.00
175	Survey - 3%	1	LS	\$54,603.66	\$54,603.66
176	Drainage Pipes and System	1	LS	\$259,200.00	\$259,200.00
177	Relocate Street Light	3	EA	\$1,500.00	\$4,500.00
178	Roadway Excavation (Plan Quantity)	27,047	CY	\$25.00	\$676,166.67
179	Remove Asphalt Pavement	4,800	SY	\$6.50	\$31,200.00
180	Relocate Sign	2	EA	\$200.00	\$400.00
181	Concrete Curb and Gutter	5,400	LF	\$28.00	\$151,200.00
182	HMA 6"	1,638	TON	\$150.00	\$245,754.00
183	Untreated Based Course 10"	1,867	CY	\$32.00	\$59,733.33
184	Granular Sub Base 12"	1,840	CY	\$28.00	\$51,520.00
185	Concrete Driveway	7,000	SF	\$20.00	\$140,000.00
186	Concrete Sidewalk	10,800	SF	\$15.00	\$162,000.00
187	4" Paint Line	4,320	LF	\$1.00	\$4,320.00
188	Sod	12,960	SF	\$1.30	\$16,848.00
189	Topsoil-6 inch thick	1,440	SY	\$12.00	\$17,280.00
				SUBTOTAL	\$2,261,970.06
				ROW Acquisition	\$0.00
				Contingency - 35%	\$791,689.52
				Design Engineering - 10%	\$226,197.01
				Construction Engineering - 10%	\$226,197.01
				Miscellaneous Item - 5%	\$113,098.50
Total:					\$3,619,200.00

 ENGINEER'S OPINION OF PROBABLE COST					
PROJECT NAME:				DATE: 2/4/2026	
Woods Cross TMP					
PROJECT DESCRIPTION:					
Roadway Cost					
CLIENT:					
City of Woods Cross					
J-U-B PROJ. NO.: 07-24-094					
No.	ITEM	QUANTITY	UNIT	UNIT COST	TOTAL COST
Mountain View Blvd - 330 Feet					
2170 S to 2260 S					
190	Mobilization - 10%	1	LS	\$55,777.34	\$55,777.34
191	Storm Water Pollution Prevention	1	LS	\$3,300.00	\$3,300.00
192	Traffic Control - 10%	1	LS	\$55,777.34	\$55,777.34
193	Clear and Grub	1	LS	\$2,640.00	\$2,640.00
194	Dust Control & Watering	1	LS	\$1,155.00	\$1,155.00
195	Survey - 3%	1	LS	\$16,733.20	\$16,733.20
196	Drainage Pipes and System	1	LS	\$79,200.00	\$79,200.00
197	Relocate Street Light	1	EA	\$1,500.00	\$1,500.00
198	Roadway Excavation (Plan Quantity)	8,264	CY	\$25.00	\$206,606.48
199	Remove Asphalt Pavement	1,467	SY	\$6.50	\$9,533.33
200	Relocate Sign	2	EA	\$200.00	\$400.00
201	Concrete Curb and Gutter	1,650	LF	\$28.00	\$46,200.00
202	HMA 6"	501	TON	\$150.00	\$75,091.50
203	Untreated Based Course 10"	570	CY	\$32.00	\$18,251.85
204	Granular Sub Base 12"	562	CY	\$28.00	\$15,742.22
205	Concrete Driveway	1,500	SF	\$20.00	\$30,000.00
206	Concrete Sidewalk	3,300	SF	\$15.00	\$49,500.00
207	Concrete Curb Ramp	4	EA	\$3,500.00	\$14,000.00
208	4" Paint Line	1,320	LF	\$1.00	\$1,320.00
209	Sod	3,960	SF	\$1.30	\$5,148.00
210	Topsoil-6 inch thick	440	SY	\$12.00	\$5,280.00
				SUBTOTAL	\$693,156.27
				ROW Acquisition	\$0.00
				Contingency - 35%	\$242,604.69
				Design Engineering - 10%	\$69,315.63
				Construction Engineering - 10%	\$69,315.63
				Miscellaneous Item - 5%	\$34,657.81
Total:					\$1,109,100.00

APPENDIX G: TRAFFIC IMPACT STUDY GUIDELINES

DRAFT

Permit Level / Traffic Study Level I

Project generates less than 100 daily trips.

No proposed modifications to traffic signals or roadway elements or geometry.

1. Study Area
 - a. Defined by City Engineer.
 - b. The study area may include property frontage, neighboring and adjacent parcels, and require applicant to identify site access points, and any access points along the roadway within access category distance of property boundaries (Refer to **Section 4.3** and **Table 5**).
2. Horizon year
 - a. Opening year of project.
3. Data Collection
 - a. AM and PM Peak period turning movement counts of site and study area.
 - I. Collect turning movement counts mid week on non-holiday weeks
 - b. Identify site and study area roadway and intersection geometries.
 - c. Identify study area traffic volume and characteristics.
 - d. Identify queue lengths at site and study intersections.
4. Analysis Period
 - a. Identify site and study area road traffic for weekday AM and PM peak hours.
5. Right-of-Way Access
 - a. Right-of-way and physical conflicts.
 - b. Investigate existence of federal or state, no access or limited access control lines.
6. Generate access point capacity analysis as necessary
 - a. Analyze the site and study area for the following time periods: weekday AM and PM peak hours including Saturday peak hours.
 - b. Identify special event peak hour as necessary (per roadway peak and site peak).
7. Design and Mitigation
 - a. Determine and document safe and efficient operational design needs based on site and study area data.
 - b. Identify operational concerns and mitigation measures to ensure safe and efficient operation.

Permit Level / Traffic Study Level II

Project generates 100 to 500 daily trips

1. Study Area
 - a. Defined by City Engineer.
 - b. The study area may include property frontage, neighboring and adjacent parcels, and require applicant to identify site, cross and next adjacent up and down stream access points within access category distance of property boundaries, the intersection of site access drives with state highways and any signalized and un-signalized intersection within access category distance of property line, including any identified queuing (Refer to **Section 4.3** and **Table 5**).
2. Horizon Year
 - a. Opening year of project.
3. Data Collection
 - a. AM and PM Peak period turning movement counts of site and study area.
 - I. Collect turning movement counts mid week on non-holiday weeks
 - b. Identify site and study area roadway and intersection geometries.
 - c. Identify study area traffic volume and characteristics.
 - d. Identify queue lengths at site and study intersections.
4. Analysis Period
 - a. Identify site and study area road traffic for weekday AM and PM peak hours.
 - b. Identify special event peak hour as necessary (study area roadway peak and site peak).
5. Capacity Analysis
 - a. Level of Service (LOS) for all intersections.
 - b. LOS for existing conditions, design year without project, design year with project.
6. Right-of-Way Access
 - a. Identify right-of-way and physical conflicts.
 - b. Investigate existence of federal or state, no access or limited access control lines.
7. Design and Mitigation
 - a. Determine and document safe and efficient operational design needs based on site and study area data.
 - b. Identify operational concerns and mitigation measures to ensure safe and efficient operation pursuant to appropriate state highway access category.

Permit Level / Traffic Study Level III

Project Generates 500 to 3,000 daily trips or less than 500 peak hour trips

1. Study Area
 - a. Defined by City Engineer.
 - b. The study area may include property frontage, neighboring and adjacent parcels, and require applicant to identify site, cross and next adjacent up and down stream access points within access category distance of property boundaries, the intersection of site access drives with state highways and any signalized and un-signalized intersection within access category distance of property line, including any identified queuing (Refer to **Section 4.3** and **Table 5**).
2. Horizon Year
 - a. Opening year of project.
 - b. Five years after opening.
 - c. Document and include all phases of development.
3. Data Collection
 - a. AM and PM Peak period turning movement counts of site and study area.
 - I. Collect turning movement counts mid week on non-holiday weeks
 - b. Identify site and study area roadway and intersection geometries.
 - c. Identify queue lengths at site and study intersections.
 - d. Traffic control devices including traffic signals and regulatory signs.
 - e. Automatic continuous traffic counts for at least 48 hours.
 - f. Traffic crash data
4. Analysis Period
 - a. For each design year analyze site and study area road traffic for weekday A.M. and P.M. peak hours.
 - b. Identify special event peak hour as necessary (study area roadway peak and site peak).
5. Trip Generation
 - a. Use equations or rates available in latest edition of ITE Trip Generation.
 - b. Where developed equations are unavailable for intended land use, perform trip rate study and estimation following ITE procedures or develop justified trip rate agreed to by the City Engineer.
6. Trip Distribution and Assignment
 - a. Document distribution and assignment of existing, site, background, and future traffic volumes on surrounding roadway network of study area.
7. Capacity Analysis
 - a. Level of Service (LOS) for all intersections.
 - b. LOS for existing conditions, design year without project, design year with project.
8. Traffic Signal Impacts
 - a. Traffic signal warrant study (prepared by developer).
 - b. Traffic signal construction drawings if traffic signal is warranted (prepared by developer).

- c. Queuing Analysis
- d. Identify traffic signal coordination with existing signals along the corridor.

9. Right-of-Way Access

- a. Identify right-of-way and physical conflicts.
- b. Investigate existence of federal or state, no access or limited access control lines.

10. Design and Mitigation

- c. Determine and document safe and efficient operational design needs based on site and study area data.
- d. Identify operational concerns and mitigation measures to ensure safe and efficient operation.

Permit Level / Traffic Study Level IV

Project generates 3,000 to 10,000 daily trips or 500 to 1,200 peak hour trips.

1. Study Area
 - a. Defined by City Engineer.
 - b. The study area may include property frontage, neighboring and adjacent parcels, and require applicant to identify site, cross and next adjacent up and down stream access points within access category distance of property boundaries, the intersection of site access drives with state highways and any signalized and un-signalized intersection within ½ mile of the property line on each side of the project (Refer to **Section 4.3** and **Table 5**).
2. Horizon Year
 - a. Opening year of project
 - b. Five years after opening.
 - c. Twenty years after opening.
 - d. Document and include all phases of development.
3. Data Collection
 - a. AM and PM Peak period turning movement counts of site and study area.
 - I. Collect turning movement counts mid week on non-holiday weeks
 - b. Identify site and study area roadway and intersection geometries.
 - c. Identify queue lengths at site and study intersections.
 - d. Traffic control devices including traffic signals and regulatory signs.
 - e. Traffic crash data.
4. Analysis period
 - a. For each design year analyze site and study area road traffic for weekday A.M. and P.M. peak hours.
 - b. Identify special event peak hour as necessary (study area roadway peak and site peak).
5. Trip Generation
 - a. Use equations or rates available in latest edition of ITE Trip Generation.
 - b. Where developed equations are unavailable for intended land use, perform trip rate study and estimation following ITE procedures or develop justified trip rate agreed to by the City Engineer.
6. Trip Distributions and Assignment
 - a. Document distribution and assignment of existing, site, background, and future traffic volumes on surrounding roadway network of study area.
7. Capacity Analysis
 - a. Level of Service (LOS) for all intersections.
 - b. LOS for existing conditions, design year without project, design year with project.
8. Traffic Signal Impacts. For proposed Traffic Signals:

- a. Traffic signal warrant study (prepared by developer).
 - b. Traffic signal construction drawings if traffic signal is warranted (prepared by developer).
 - c. Queuing analysis.
 - d. Identify traffic signal coordination with existing signals along the corridor.
9. Right-of-Way Access
- a. Identify right-of-way and physical conflicts.
 - b. Investigate existence of federal or state, no access or limited access control lines.
10. Traffic Safety Analysis.
- a. Identify crash trends.
 - b. Identify crash mitigation measures.
11. Design and Mitigation
- a. Determine and document safe and efficient operational design needs based on site and study area data.
 - b. Identify operational concerns and mitigation measures to ensure safe and efficient operation.

Permit Level / Traffic Study Level V

Project generates more than 10,000 daily trips or more than 1,200 peak hour

1. Study Area
 - a. Defined by City Engineer.
 - b. The study area may include property frontage, neighboring and adjacent parcels, and require applicant to identify site, cross and next adjacent up and down stream access points within access category distance of property boundaries, the intersection of site access drives with state highways and any signalized and un-signalized intersection within ½ mile of the property line on each side of the project (Refer to **Section 4.3** and **Table 5**).
 2. Horizon Year
 - a. Opening year of project.
 - b. Five years after opening.
 - c. Twenty years after opening.
 - d. Document and include all phases of development.
 3. Data Collection
 - a. AM and PM Peak period turning movement counts of site and study area.
 - I. Collect turning movement counts mid week on non-holiday weeks
 - b. Identify site and study area roadway and intersection geometries.
 - c. Identify queue lengths at site and study intersections.
 - d. Traffic control devices including traffic signals and regulatory signs.
 - e. Traffic crash data.
 4. Analysis period
 - a. For each design year analyze site and adjacent road traffic for weekday A.M. and P.M. peak hours.
 - b. Identify special event peak hour as necessary (adjacent roadway peak and site peak).
 5. Trip Generation
 - a. Use equations or rates available in latest edition of ITE Trip Generation.
 - b. Where developed equations are unavailable for intended land use, perform trip rate study and estimation following ITE procedures or develop justified trip rate agreed to by the City Engineer.
 6. Trip Distributions and Assignment
 - a. Document distribution and assignment of existing, site, background, and future traffic volumes on surrounding network of study area.
 7. Capacity Analysis
 - a. Level of Service (LOS) for all intersections.
 - b. LOS for existing conditions, design year without project, design year with project.
 8. Traffic Signal Impacts
 - a. Traffic signal warrant study (prepared by developer).
 - b. Traffic signal construction drawings if traffic signal is warranted (prepared by developer).
-

- c. Queuing Analysis.
 - d. Identify traffic signal coordination with existing signals along the corridor.
9. Right-of-Way Access
- a. Identify right-of-way, geometric boundaries and physical conflicts.
 - b. Investigate existence of federal or state, no access or limited access control line.
10. Traffic Safety Analysis
- a. Identify crash trends.
 - b. Identify crash mitigation measures.
11. Design and Mitigation
- a. Determine and document safe and efficient operational design needs based on site and study area data.
 - b. Identify operational concerns and mitigation measures to ensure safe and efficient operation pursuant to appropriate state highway access category.

Application Submittal and TIS Report Format

The applicant must submit one complete application with attachments to the City Engineer. Please include scaled schematic drawings illustrating alignment, number of lanes, lane widths, signing, and pavement markings. If traffic signal modifications are proposed, drawings must show signal phasing, signal head locations and lane markings.

The Traffic Impact Study must follow the recommended format below.

1. Introduction and summary
2. Proposed project description
3. Existing study area conditions
4. Analysis of existing conditions
5. Projected site trips
6. Analysis of projected traffic
7. Conclusions and recommendations