

# NSL Trails & Active Transportation Committee



MARCH 10, 2026



# Agenda

1. Welcome & Introductions
2. Public Comment
3. Approval of Minutes of Feb 10, 2026 Meeting
4. Review and Discussion of Health and Wellness Project
5. Staff Updates
6. City Council Updates
7. Committee Member Discussion Items
8. Discussion and Coordination of 2026 Events
9. Training on SharePoint Site Updates
10. Discussion on Future Agenda(s)
11. Adjourn

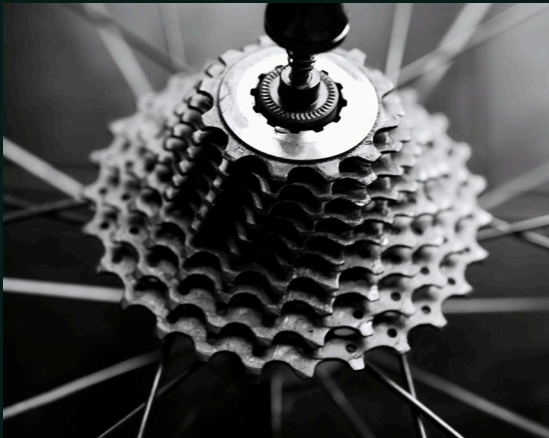

# Welcome & Introductions



## Staff Liaisons:

- Jon Rueckert, Public Works Director
- TJ Riley, Parks Superintendent
- Ali Avery, Long Range Planner

## Committee Members:

- Ted Knowlton, City Council
- Ryan Oakes – Chair
- Pedro Huebner – Vice Chair
- Kyle Poulter
- Brent Crowther
- Peter Wirthlin



# Public Comment

March 10, 2026





# Feb 10<sup>th</sup>, 2026 Meeting Minutes Approval

March 10, 2026



# Possible Motion

---

I move that the Trails and Active Transportation Committee formally approve the Meeting Minutes from the February 5<sup>th</sup>, 2026 Meeting.



# Review and Discussion of Health & Wellness Project

March 10, 2026





# Staff Updates

March 10, 2026



# Staff Updates

## TRAILS MASTER PLAN

- Community Engagement Plan
- Project Area
- Trail Photos
- Steering Committee:
  - 3-5 goals for trail system
  - What trails or areas should be prioritized?
  - What are the problem areas/watchouts?
  - Stakeholders?

Date	Event	Purpose	Option A	Option B
4/25/26	Arbor Day Planting	Community feedback on vision, desires, preferences	SE Group attends and leads engagement at event ("open house")	North Salt Lake leads; SE Group provides boards but does not attend
April	Stakeholder meeting	Building trust and partnership with stakeholder agencies/municipalities	SE Group attends and facilitates during site visit (in person)	SE Group facilitates in hybrid format (in person/remote) in April
6/6/25	National Trails Day	Community feedback on draft recommendations	North Salt Lake leads; SE Group provides boards but does not attend	SE Group attends and leads engagement at event ("open house")

# North Salt Lake Trails Master Plan

## Proposed Project Area

Date Exported: March 2, 2026

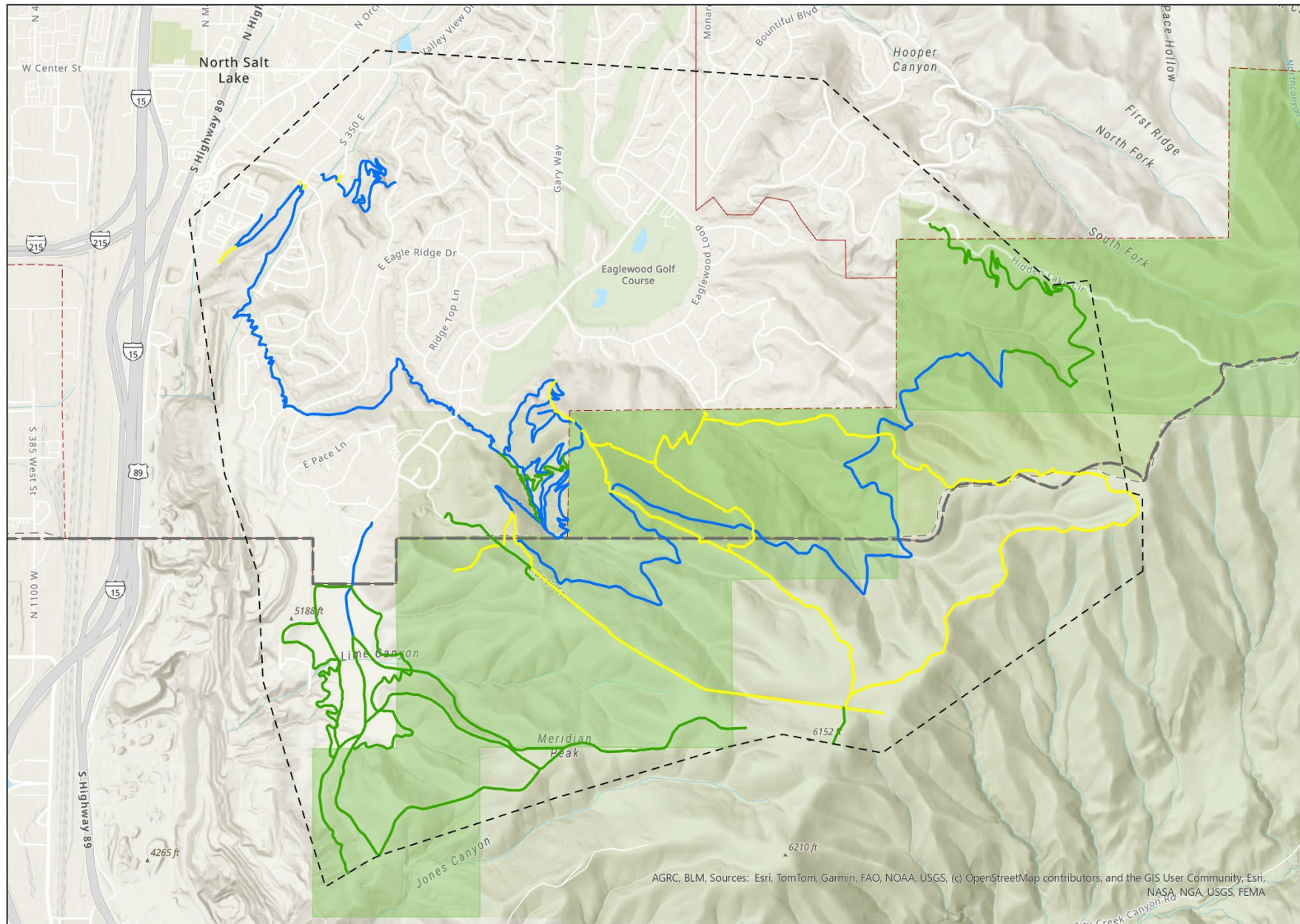

### Legend

Proposed Project Area  
 Trails\_composite

**Trails by Data Source**  
 City  
 City - Unsanctioned  
 Other Sources

**Administrative Boundaries**  
 Utah County Boundaries  
 Municipal Boundaries  
 National Forest

AGRC, BLM, Sources: Esri, TomTom, Garmin, FAO, NOAA, USGS, (c) OpenStreetMap contributors, and the GIS User Community, Esri, NASA, NGA, USGS, FEMA

# Staff Updates

---

## WILD ROSE TO BST CONNECTOR

- Working with USFS about alignment (landowner agreement letter)
- Submitting Utah Outdoor Recreation Infrastructure grant application this week (\$15k grant request)
- Next steps – ~~check in with Forest Service about alignment (use 2020 decision? Field visits likely needed)~~, hire trail designer/builder, flag trail on the ground with USFS, build trail, agreement with Davis County regarding maintenance, agreement with USFS/SLC/NSL about trail ownership

## SOUTH DAVIS GREENWAY FEASIBILITY STUDY

- [www.southdavisgreenway.org](http://www.southdavisgreenway.org) (take survey under “engage with us”)
- Sidewalk decals and sign at community garden
- Update to City Council on April 7th

# NORTH SALT LAKE

# FARMINGTON

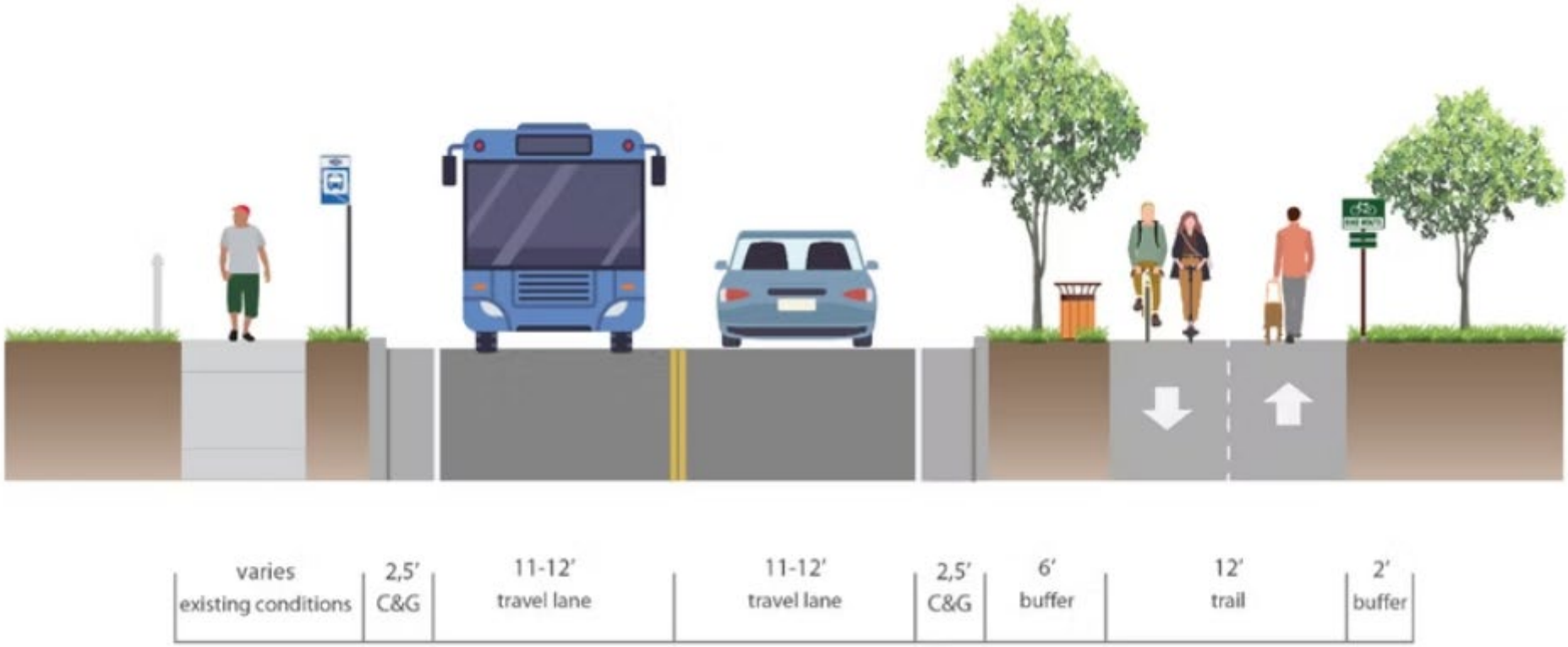
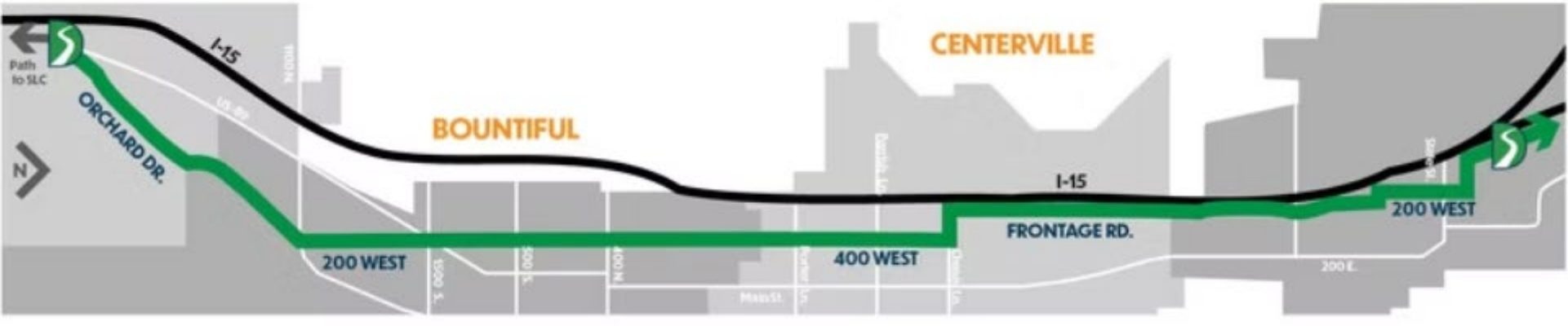

# Staff Updates

## STANDARD FOR BIKE RACKS

- Stainless Steel Inverted U design – 20”-24” W x 32”-36” H (Approximate Cost \$230 each)
- Preferably In-ground mounted in concrete pad spaced 36” - 48” apart from adjacent racks, parking areas, and walkways.

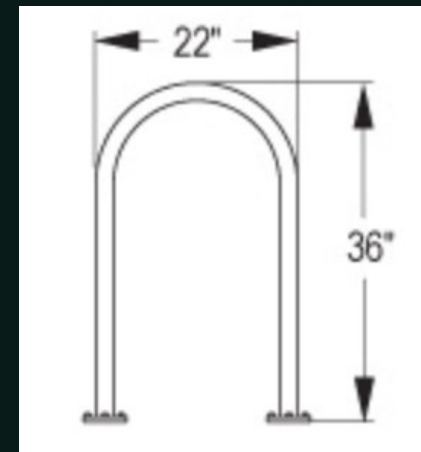



# City Council Updates

March 10, 2026





# Committee Member Discussion Items

February 10, 2026





# Discussion and Coordination of 2026 Events

March 10, 2026



# 2026 Events

---

## PURGE THE SPURGE

- April 11<sup>th</sup>, 10am Springhill Geologic Park
- Tabling by Committee for Trails Master Plan

## ARBOR DAY

- April 25<sup>th</sup>, 9am (Location TBD)
- Tabling by Committee / SE Group for Trails Master Plan

## CLEANUP EVENTS

- May 9th, 8am Wild Rose Parkway Drive section
- August (Date, Time, Location TBD)

- October (Date, Time, Location TBD)

## GOLDEN SPOKE

- May 16<sup>th</sup> (Legacy Park, time TBD)

## NATIONAL TRAILS DAY

- June 6<sup>th</sup> (Time? Location?)
- Tabling for completed Trails Master Plan

## 9 / 11 DAY OF SERVICE

- September 5<sup>th</sup> (Time? Location?)

## GET TO THE RIVER

- September 12<sup>th</sup> (8:30am, Riverview Boat Ramp)



# Training on SharePoint Site Updates

March 10, 2026





# Future Agenda(s)

March 10, 2026





Adjourn

March 10, 2026

