



## **CLINTON CITY COUNCIL AGENDA**

2267 N 1500 W Clinton, UT 84015

AMENDED

**SEPTEMBER 9, 2025**

Live stream can be found on YouTube at [youtube.com/@ClintonCityUtah](https://youtube.com/@ClintonCityUtah)

**This meeting may be attended electronically by one or more members.**

### **6:00 PM REGULAR CITY MEETING**

1. Call to Order
2. Pledge of Allegiance and Invocation or Thought – Gary Tyler
3. Roll Call

### **PUBLIC INPUT**

*Any public member who wishes to address the Council shall, prior to the meeting, sign the "list to present" with the Clerk of the Council. They will be allowed up to three minutes to make their presentation. The public comment portion of the meeting will not exceed 30 minutes. Please send requests to [ltitensor@clintoncity.com](mailto:ltitensor@clintoncity.com) or call 801-614-0700. According to the Utah State Code, the Council cannot act on items not advertised on the agenda.*

### **CONSENT AGENDA**

- a. Approval of Minutes: August 26, 2025
- b. Approval of Accounts Payable: August 2025

### **BUSINESS**

- a. Fire Department Badge Pinning
- b. Police Lt Badge Pinning

### **OTHER BUSINESS**

- a. Planning Commission Report
- b. City Manager's Report
- c. Staff Reports
- d. Council Reports on Areas of Responsibility
- e. Mayor's Report
- f. Action Item Review

### **ADJOURN**

### **WORK SESSION**

- a. RAP Tax Priority Discussion
- b. 2026 Heritage Days Discussion
- c. Communications Discussion

### **ADJOURN**

Dated this 3<sup>rd</sup> day of September 2025  
/s/Lisa Titensor, Clinton City Recorder

- *Supporting documentation for this agenda is posted on the Clinton City website at [www.clintoncity.com](http://www.clintoncity.com) and on the Utah Public Notice Website [www.utah.gov/pmn](http://www.utah.gov/pmn)*
- *In compliance with the American with Disabilities Act, individuals needing special accommodation (including auxiliary communicative aids and service) during the meeting should notify Lisa Titensor, City Recorder, at (801) 614-0700 at least 24 hours prior to the meeting.*
- *This meeting may involve electronic communications for some members of this public body. The anchor location for the meeting shall be the Clinton City Council Chambers at 2267 N 1500 W Clinton UT 84015. Elected Officials at remote locations may be connected to the meeting electronically to participate.*

**Mayor  
Brandon Stanger**

**City Council  
Spencer Arave  
Marie Dougherty  
Austin Gray  
Dane Searle  
Gary Tyler**

- ***Notice is hereby given that by motion of the Clinton City Council, pursuant to Utah State Code Title 52, Chapter 4 sections 204 & 205, the City Council may vote to hold a closed session for any of the purposes identified in that Chapter.***
- ***The order of agenda items may change to accommodate the needs of the city council, staff and/or public***

## CLINTON CITY COUNCIL MEETING MINUTES

**Date:** August 26, 2025

**Time:** 6:00 PM

**Location:** 2267 N 1500 W, Clinton, UT 84015

**Mayor:** Brandon Stanger



**City Council:** Spencer Arave, Marie Dougherty, Austin Gray, Dane Searle, Gary Tyler

**Staff:** City Manager Trevor Cahoon, Chief Financial Officer Aaron Price, Police Chief Shawn Stoker, Treasurer Steve Hubbard, Public Works Director David Williams, Fire Chief Jason Poulsen, Recreation Director Brooke Mitchell

**Attendees:** Dereck Bauer, Hannah Klebe, Mary Frederickson, Bev Lambdin, Kirby Crowley, Terry Tremea, Chandra Weisbecker, C Johns, Rowan Johns, Wendy Tremea, Jennifer Christensen, Adam & Deanna Larsen, Russell Arave, Richard Lee, Kathy Ostberg,

---

### CALL TO ORDER

Mayor Stanger called the meeting to order at 6:00 PM.

### PLEDGE OF ALLEGIANCE & INVOCATION or THOUGHT

Councilmember Austin Gray led the pledge and offered a thought, a quote by Helen Keller emphasizing the importance of small daily tasks and integrity in City Council responsibilities.

### ROLL CALL

Mayor Stanger, Councilmembers Arave, Dougherty, Gray, Searle, and Tyler were all present.

### PUBLIC INPUT

There was none.

### 1. CONSENT AGENDA

**1a. Approval of Minutes - July 8, 2025, August 5, 2025, and August 12, 2025, Special City Council Meetings**

**1b. Approval of Accounts Payable – July 2025**

**1c. Award Contract for 2025 Surface Treatment**

Councilmembers asked clarifying questions regarding equipment rentals noted in accounts payable (answered by Public Works Director David Williams) and future auditor rotation practices (explained by Mayor Stanger).

### MOTION

**Councilmember Searle moved to approve the consent agenda. Councilmember Gray seconded the motion. Voting is as follows: Councilmember Arave, aye; Councilmember Dougherty, aye; Councilmember Gray, aye; Councilmember Searle, aye; Councilmember Tyler, aye.**

## **2. BUSINESS ITEMS**

### **2A. RAP TAX COMMITTEE PRESENTATION**

Members of the RAP Tax Committee are as follows: Terry Tremea (Parks), Kathy Ostberg (Arts), Randy Halley (Rec), Jason McKaughan (Parks), Jose Gomez (Arts), Chandra Weisbecker (Rec), Stephanie Spor (Parks), Sam Macias (Arts)

The RAP Tax Committee presented a detailed PowerPoint (Attachment A) on community engagement and funding recommendations. Committee members Terry Tremea and Chandra Weisbecker described outreach efforts at Heritage Days and the Easter Hop, where residents overwhelmingly requested a splash pad, recreation center, and more shaded areas in parks.

Highlights included:

- 132 suggestions gathered from Heritage Days survey box.
- Top requests: Rec Center, Splash Pad, Shade Structures, Dog Park.
- Recommendations: 20% of annual funds set aside for future large projects; initial priorities include shade installations, dog park development, arts funding, and signage.

Council Discussion:

Councilmember Gary Tyler presented cost realities for Rec Centers and Splash Pads, estimating Rec Centers at \$25–35 million and annual operating deficits requiring taxpayer subsidies.

Councilmember Spencer Arave and Councilmember Dane Searle supported increasing the percentage of RAP funds reserved beyond 20% to accelerate progress toward major projects.

Councilmember Marie Dougherty emphasized balancing quick community wins (dog park, shade) with long-term investments and expressed interest in unfinished parks like Pond Park.

Councilmember Spencer Arave urged the Council not to dismiss a Rec Center prematurely, suggesting grants and phased approaches.

Councilmember Gary Tyler reiterated infrastructure needs (water/sewer lines, roads) must be prioritized over aspirational projects.

Mayor Stanger supported setting aside more funds (up to 25%) for large projects and noted public expectation that RAP funds would deliver visible results.

City Manager Cahoon recommended continuing this discussion in a work session scheduled for September 9, 2025.

Mayor Stanger asked Mr. Cahoon to investigate costs for a splash pad.

## **2B. PRESENTATION BY DAVIS WEBER COUNTIES CANAL COMPANY**

The DWCCC provided a PowerPoint presentation (Attachment B).

Representatives from DWCCC reviewed current water rates and proposed increases.

Mayor Stanger expressed concern about rate equity.

## **2C. RESOLUTION 09-25 2025 MUNICIPAL PRIMARY ELECTION CANVASS**

City Recorder Lisa Titensor presented the official canvass report from Davis County for the 2025 Municipal Primary Election, (Attachment C).

### **MOTION**

**Councilmember Arave moved to adopt Resolution 09-25 certifying the results of the August 12, 2025 Primary Election. Councilmember Searle seconded the motion.**

**Voting by roll call: Councilmember Arave, aye; Councilmember Dougherty, aye; Councilmember Gray, aye; Councilmember Searle, aye; Councilmember Tyler, aye.**

### **OTHER BUSINESS**

Planning Commission Report – The Planning Commission will meet the end of September.

City Manager Report – City Manager Trevor Cahoon reported on the following:

- Utah League of Cities and Towns Annual Training – October 1-3.
- There is ongoing work on Pond Park planning.

### **STAFF REPORTS**

- Fire Chief Jason Poulsen announced Justin Benavides' retirement open house will be on Aug. 26, 2025.
- The police department and the fire department are holding a special 911 ceremony on 9/11/25 at 6:30 am in honor of the events that took place 24 years ago.

### **COUNCIL REPORTS ON AREAS OF RESPONSIBILITY**

Councilmember Arave

- Report on Arts Board activities.

Councilmember Dougherty

- Reported regarding the League Policy Committee Meeting, a new water usage fee (effective 2027) will be implemented by Legislative mandate – the culinary water consumption fee will be based on usage.

Councilmember Gray

- nothing to report at this time.

Councilmember Searle:

- He will attend a Sewer Board meeting on Wednesday, August 26, 2025. They will be addressing bio solids.

Councilmember Tyler:

- Reported on the Davis Chamber of Commerce.

Mayor Stanger's Report:

- discussed RAP Tax next steps and confirmed staff will gather cost estimates for a splash pad.

## **ADJOURNMENT**

**Councilmember Searle moved to adjourn. Councilmember Dougherty seconded the motion. All voted in favor. The meeting was adjourned at approximately 7:49 PM.**

---

*Reviewed and Approved by the Clinton City  
Council this 9<sup>th</sup> of September 2025*

*/s/ Lisa Titensor  
Clinton City Recorder*



**CLINTON CITY**  
**RAP TAX**

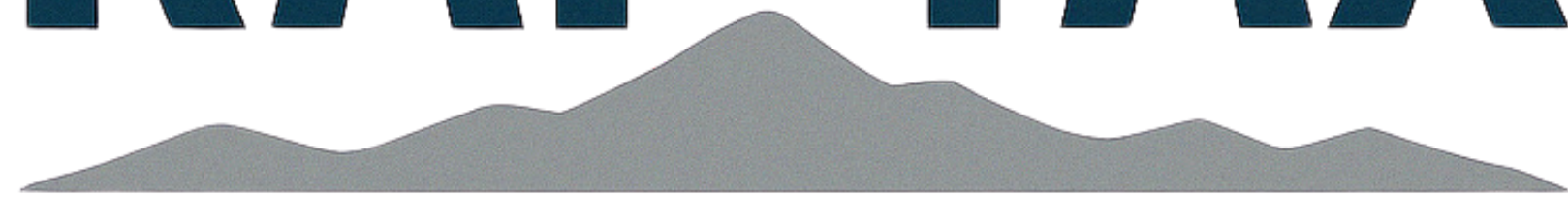

**RECREATION • ARTS • PARKS**

**PRESENTS**

# COMMUNITY INPUT AND COMMITTEE RECOMMENDATIONS

HERITAGE  
DAYS

EASTER HOP

MONTHLY  
MEETINGS



# HERITAGE DAYS

COMMUNITY INPUT:

WE RECEIVED

**132** PAPER

SUGGESTIONS



# HERITAGE DAYS

## TOP SUGGESTIONS:

- REC CENTER
- SPLASH PAD
- MORE SHADE
- ADDITIONAL REC PROGRAMS
- ARCHERY/SHOOTING RANGE



RECREATION • ARTS • PARKS

# **REC CENTER SUGGESTIONS INCLUDED:**

- VOLLEYBALL
- TUMBLING
- TACKLE FOOTBALL
- HOCKEY (ICE & STREET)
- BOYS/GIRLS CLUB
- AFTERSCHOOL PROGRAMS
- YEAR ROUND/EXTENDED BASEBALL PROGRAMS
- WRESTLING
- CHEER/DANCE
- POOL
- GYM
- TRACK

**THE COMMUNITY  
OVERWHELMINGLY  
WANTS A  
SPLASH PAD &  
RECREATION  
CENTER**

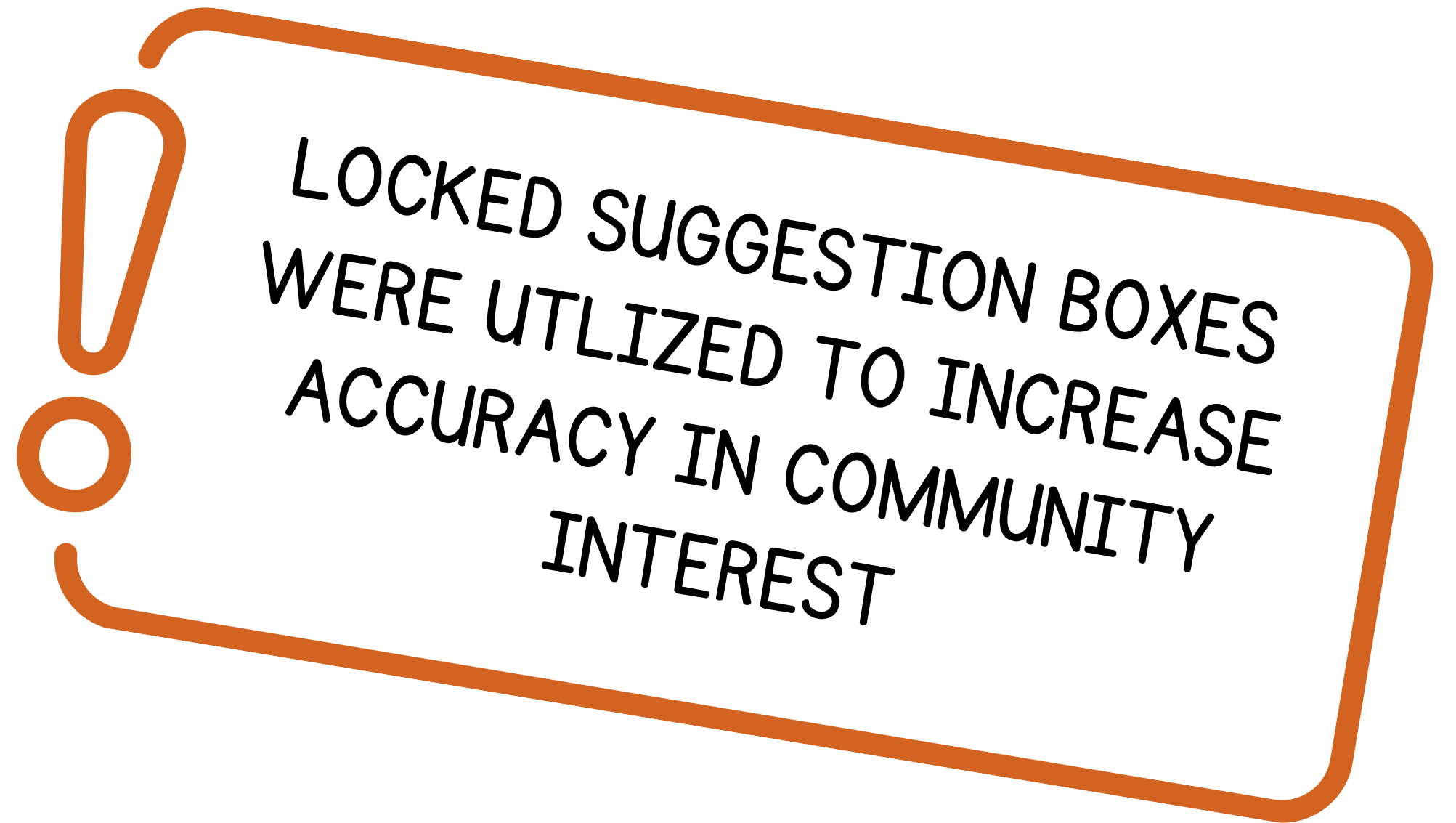

LOCKED SUGGESTION BOXES  
WERE UTILIZED TO INCREASE  
ACCURACY IN COMMUNITY  
INTEREST

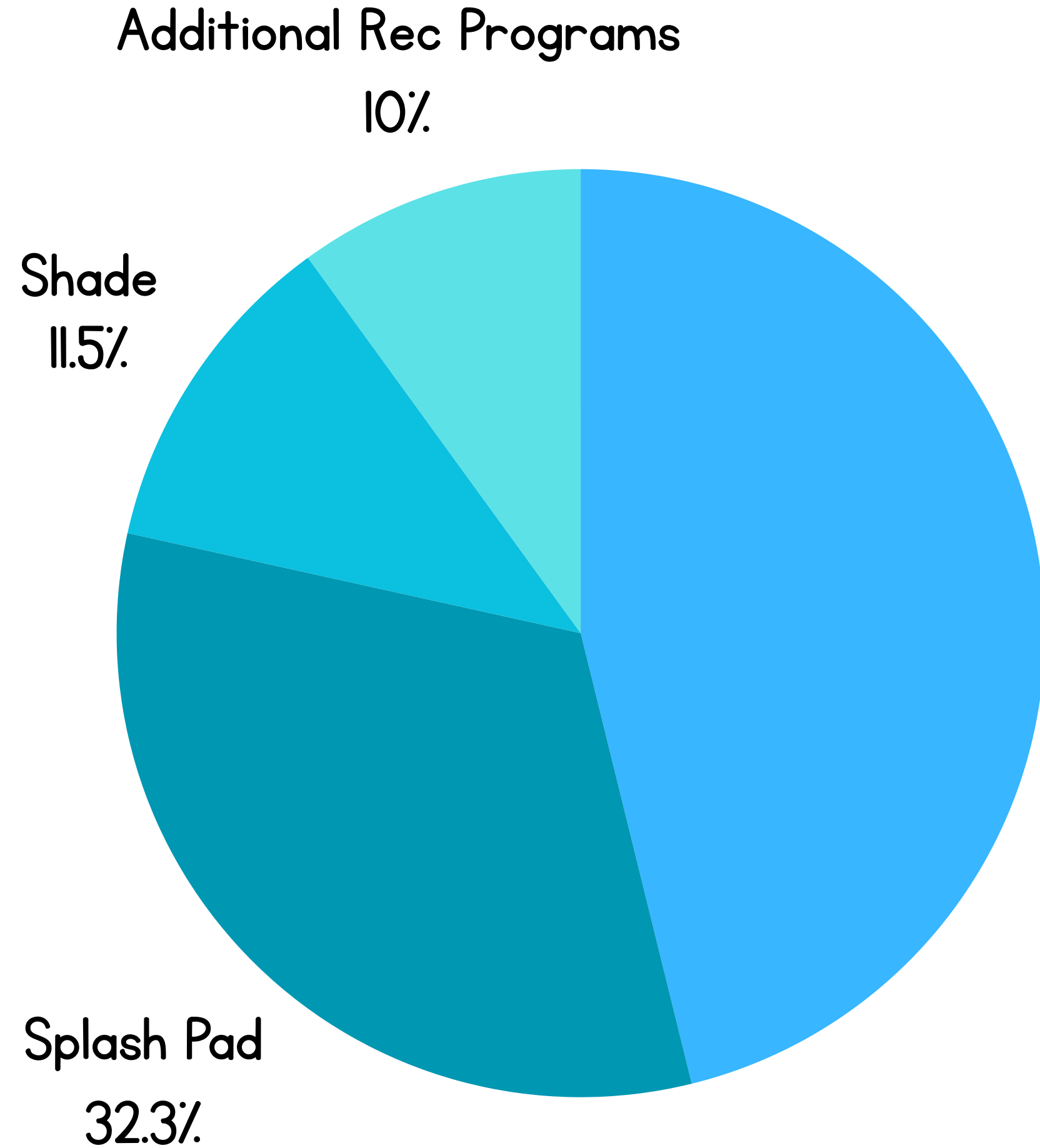

**FORMAL  
BREAKDOWN  
OF THE  
132  
COMMUNITY  
SUGGESTIONS  
RECEIVED**

# **ADDITIONAL SUGGESTIONS INCLUDED:**

- MUD PARK
  - SKATING RINK
  - WATERPARK
  - DOG PARK
  - PAINTING CLASSES
  - COMMUNITY EVENTS
  - COACHING
  - EDUCATION/RESOURCES
  - COMPETITIVE RECREATION TOURNAMENTS
- MORE WIDESPREAD COMMUNICATION OF INFORMATION/EVENTS**

# COMMITTEE RECOMMENDATIONS

DOG PARK

ROLLOVER

SHADE

ARTS  
FUNDING

GENERAL  
FUND

CLINTON  
CITY

# DOG PARK

SHOE  
STRING

QUOTE  
RECEIVED  
FOR  
\$510,000

KESTREL

HOLDING  
POND  
CAN OFFER  
\$50,000

CIVIC  
CENTER

SEVERAL  
OPTIONS  
CAN OFFER  
\$50,000

# SHOESTRING DOG PARK

\$510,000

BID

RECEIVED

2,224 FT

PERIMETER

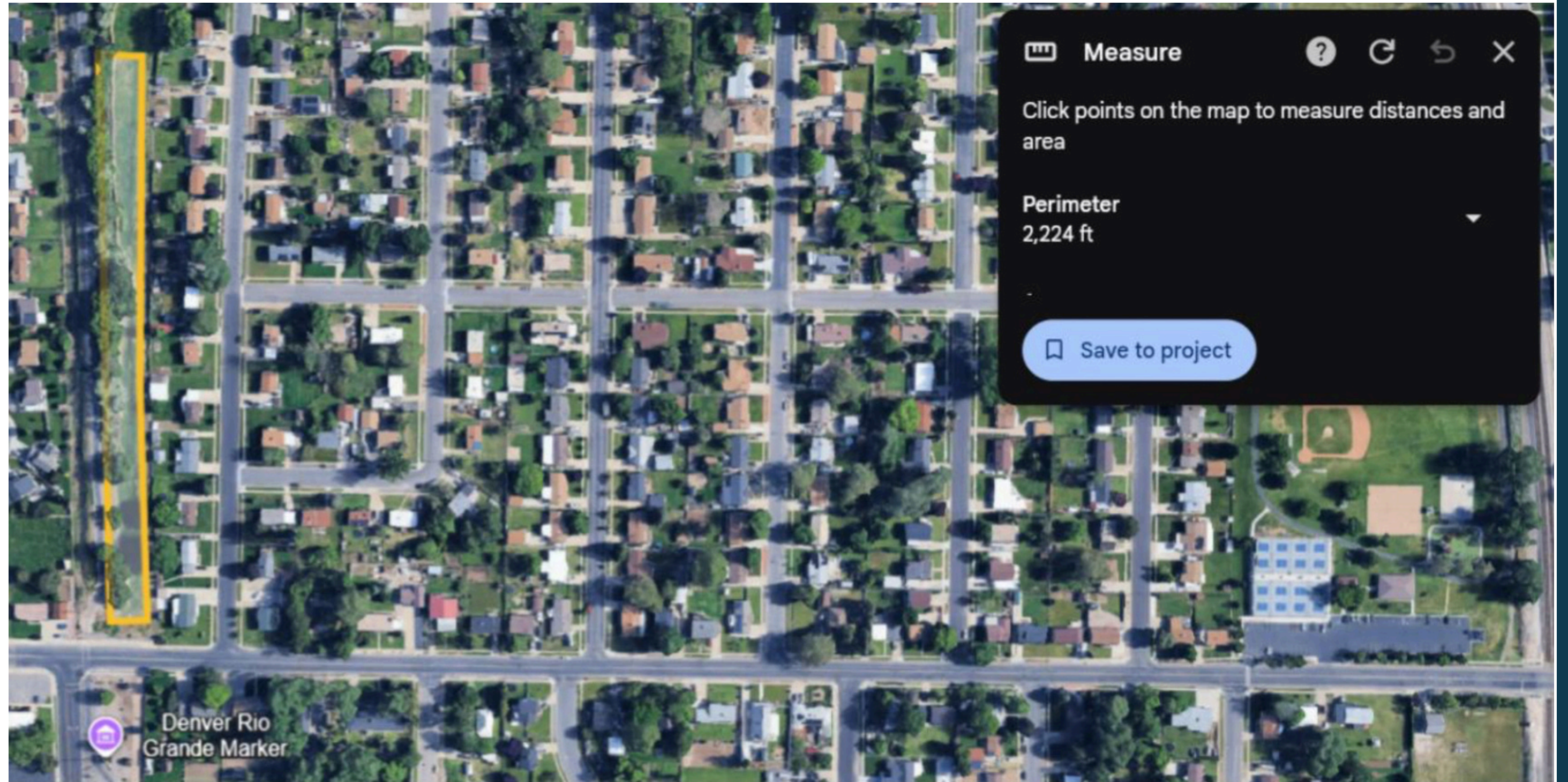

# **DOG PARK**

## **RECOMMENDATIONS**

- 6 FT FENCING
- DOUBLE ENTRY
- GATE FOR MOWING
- WATER STATIONS
- PET CLEANUP STATIONS
- MOW STRIP

# CIVIC CENTER DOG PARK

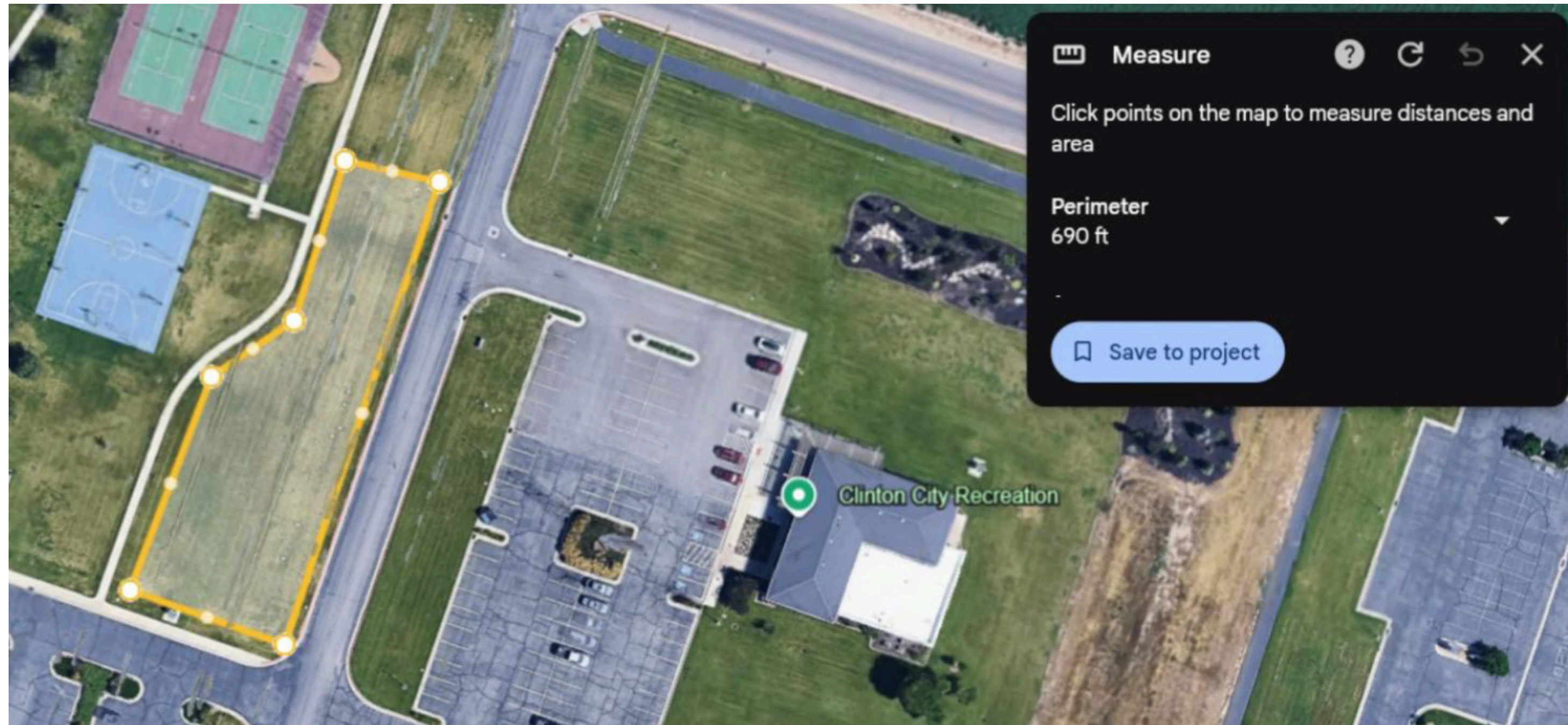

690 FT PERIMETER

# CIVIC CENTER DOG PARK

715 FT PERIMETER

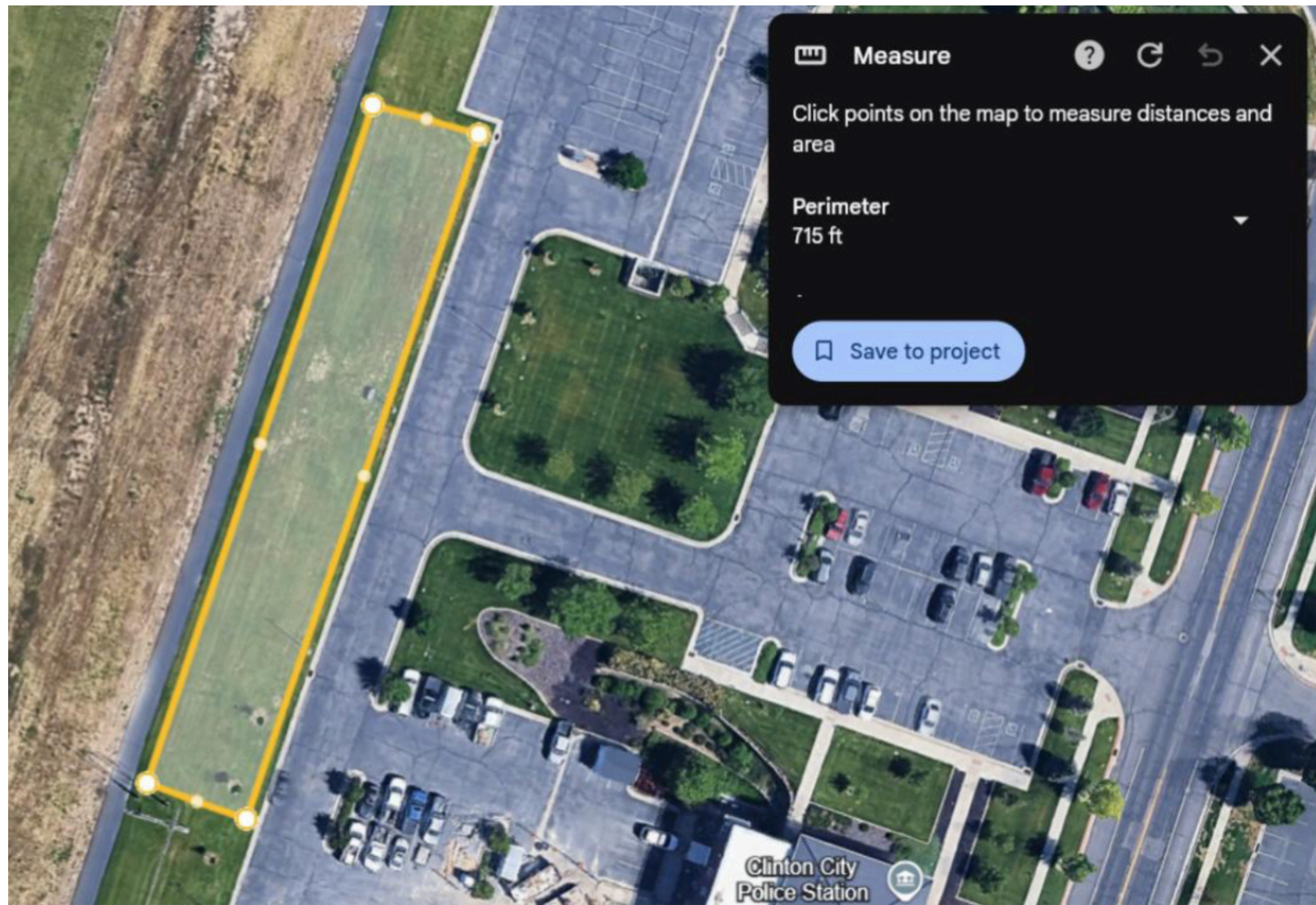

# KESTREL DOG PARK

809 FT PERIMETER



# NEIGHBORING DOG PARKS

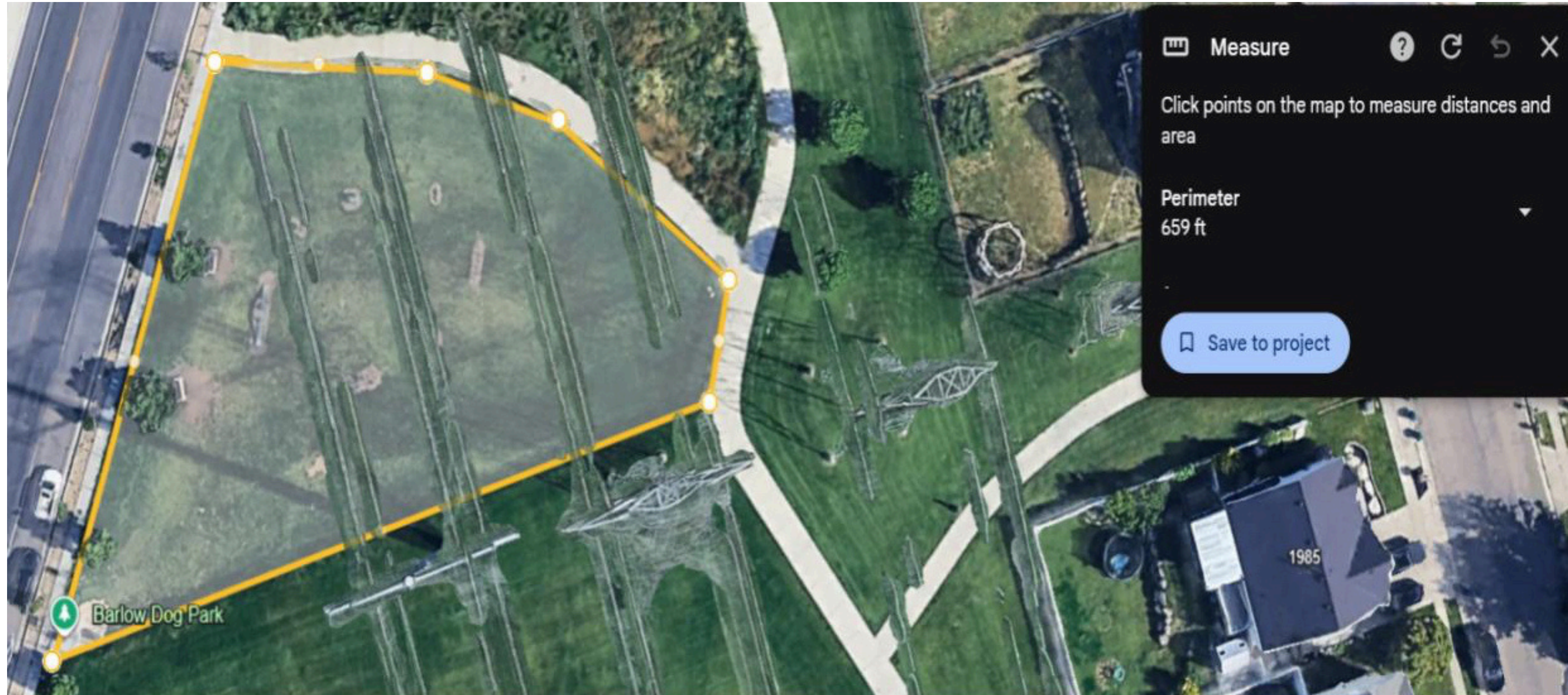

659 FT PERIMETER - BARLOW DOG PARK, CLEARFIELD

# NEIGHBORING DOG PARKS

811 FT  
PERIMETER  
-  
ROY DOG PARK

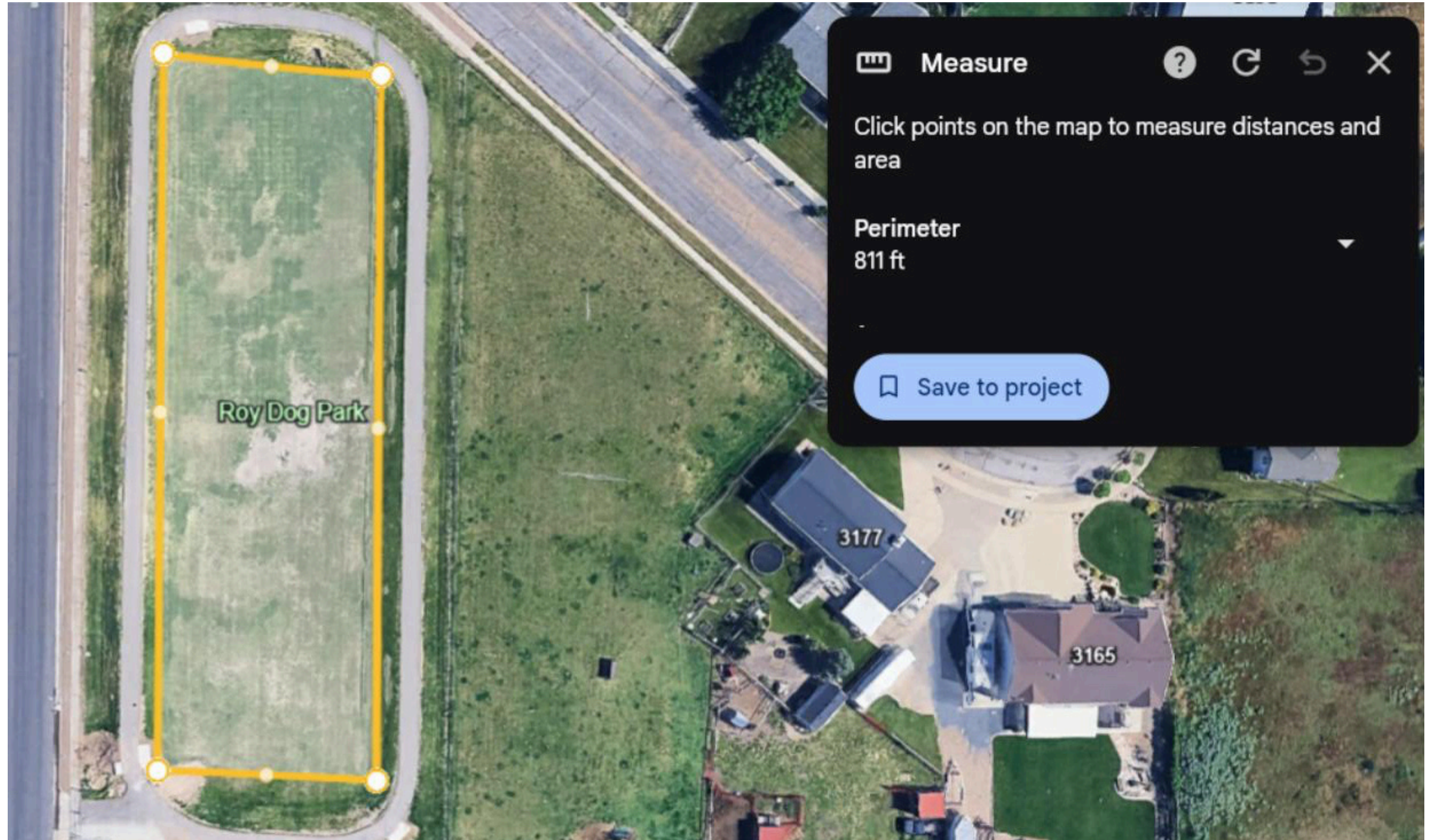

# ROLLOVER

RAP TAX COMMITTEE REQUESTS  
20% OF YEARLY FUNDS TO BE SET ASIDE TO FUND  
LARGER PROJECTS. THIS FUND COULD EVENTUALLY  
FUND WISHLIST PROJECTS, SUCH AS:

REC  
CENTER

SPLASH  
PAD

ARTS  
CENTER

# CIVIC CENTER PARK SHADE

MULTIPLE BIDS RECEIVED

SAILS

UMBRELLA

DUGOUT

SWINGS

# SHADE

CIVIC  
CENTER  
PARK  
PLAYGROUND  
SAILS

- \$217,000

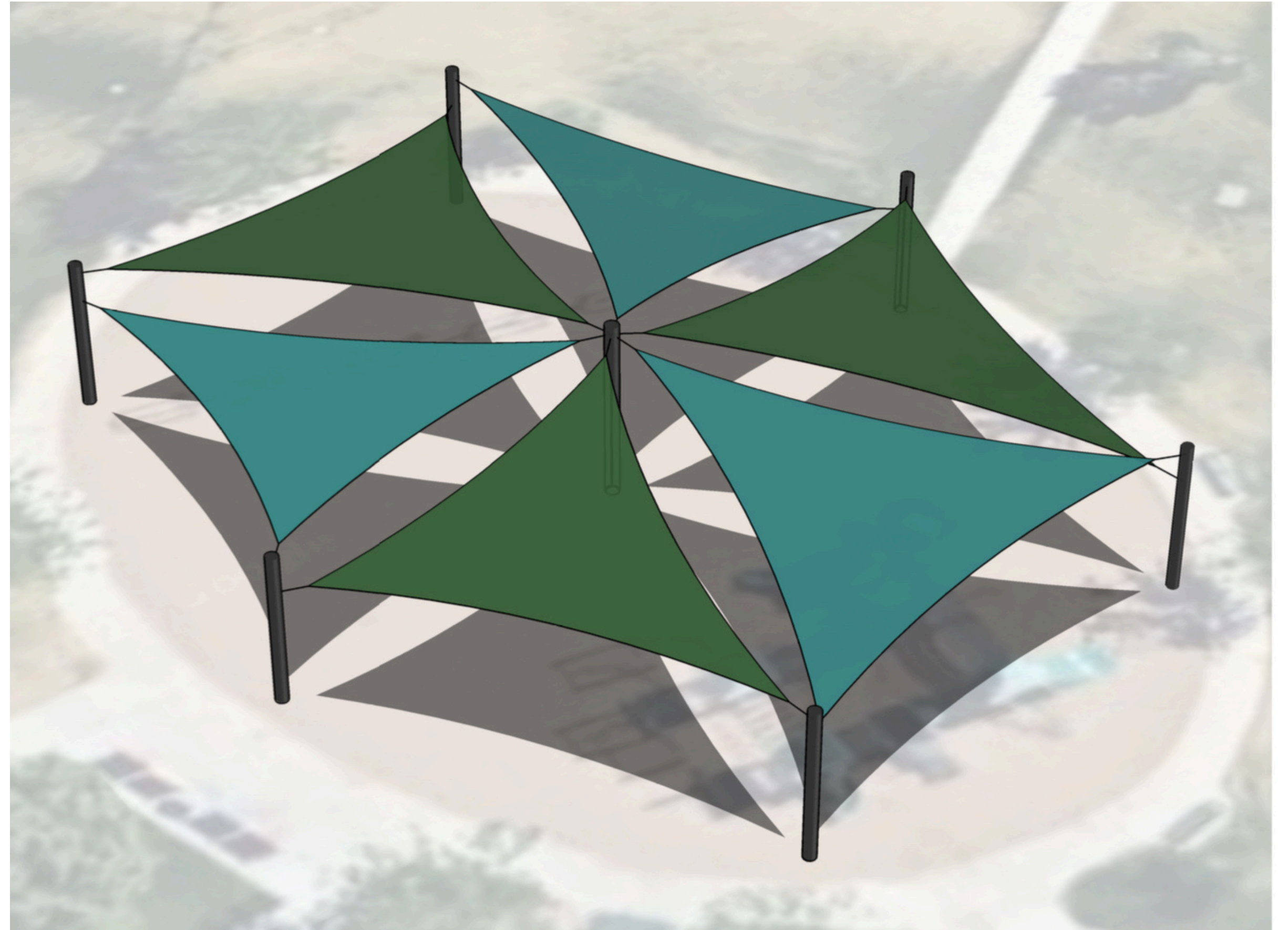

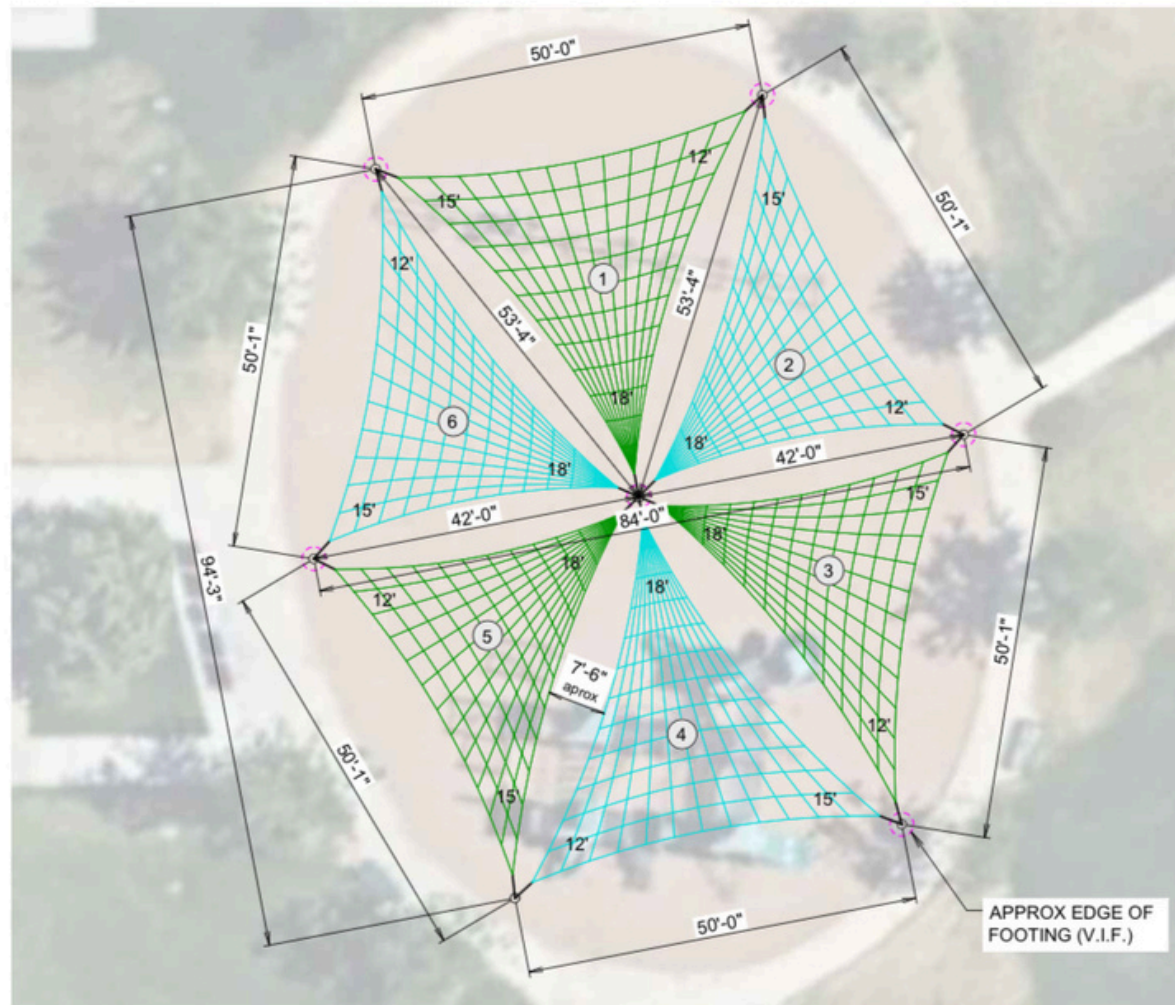

COVERAGE AREA	
PANEL #	SQ FT
PANEL 1,4	733.8
PANEL 2,3,5,6	606.3
TOTAL	3893.0

PLAN VIEW

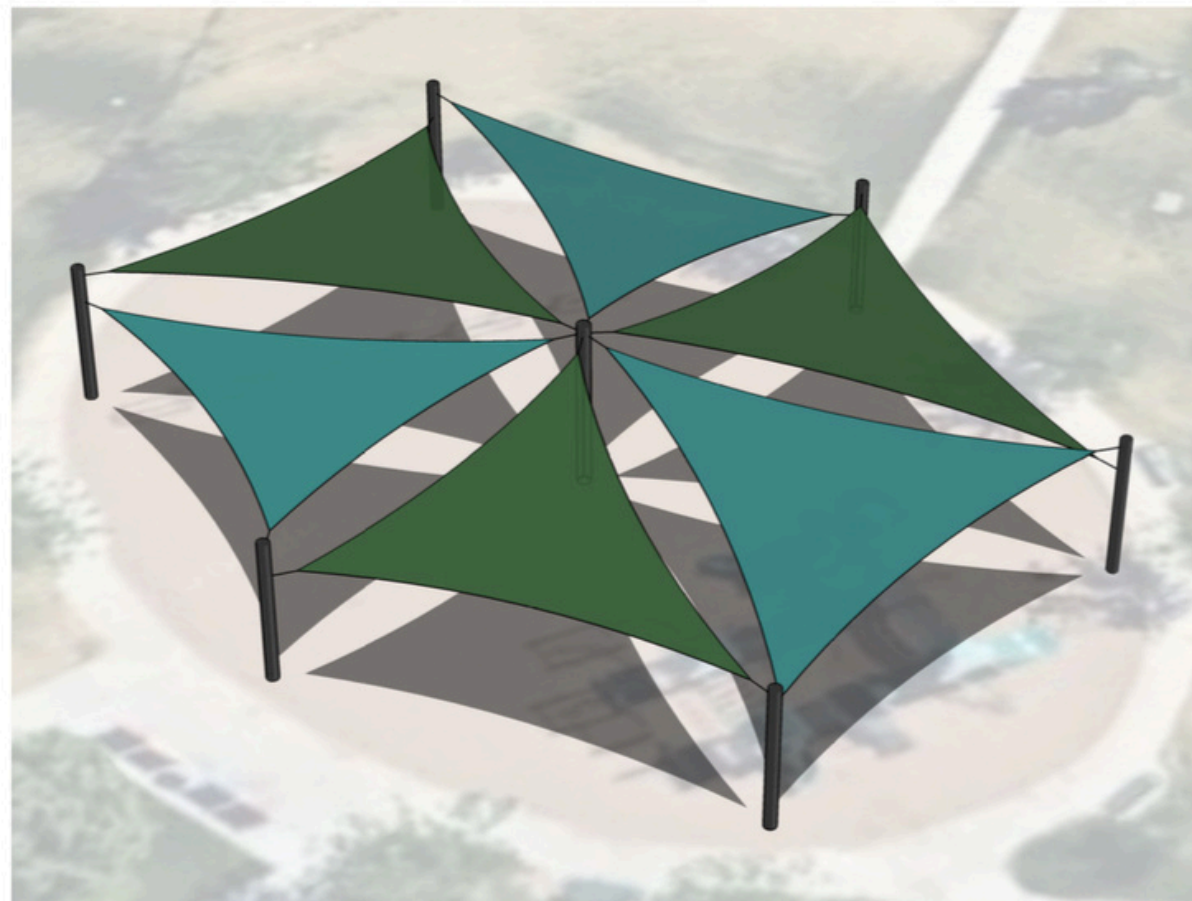

PERSPECTIVE VIEW

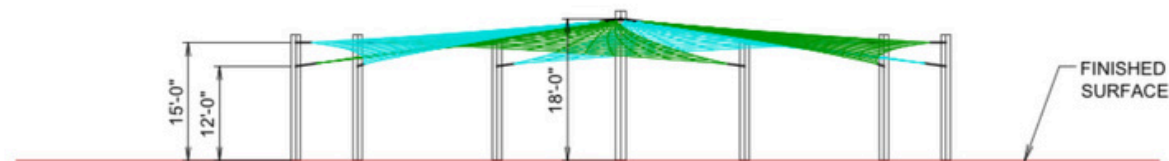

SOUTH ELEVATION

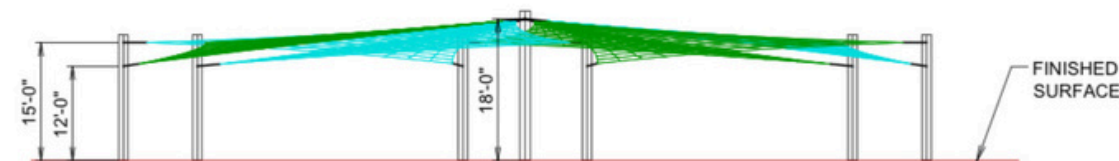

WEST ELEVATION

As manufactured and installed by:  
USA SHADE & Fabric Structures.

Nathan Hrabal  
(214) 206-1040, (800) 966-5005  
[Nathan.Hrabal@usa-shade.com](mailto:Nathan.Hrabal@usa-shade.com)

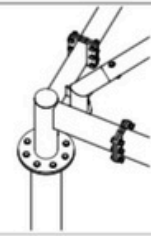
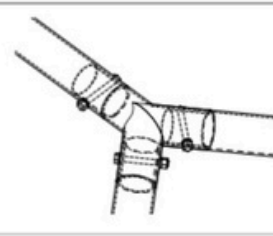
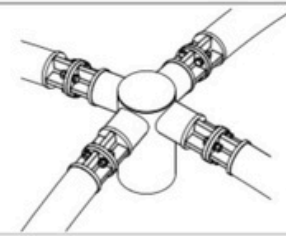
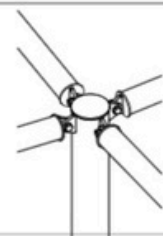

Notes:

- All structures will have bolted connections for shipping and installations purposes.
- Standard details being shown as an example. Final details t.b.d. during final Engineering phase.
- All dimensions and heights must be field verified prior to any final design, fabrication or installation work

CUSTOMER:  
**BIG T RECREATION**

PROJECT NAME:  
**CIVIC CENTER PARK**

LOCATION:  
2300 1700 W  
CLINTON, UT 84015

STRUCTURE TYPE:  
**3PT SAILS JOINED**

SIZE:  
**VARIES**

THESE PLANS AND SPECIFICATIONS ARE THE PROPERTY OF  
AND SHALL NOT BE REPRODUCED WITHOUT THEIR WRITTEN PERMISSION.

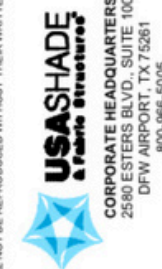

**USA SHADE**  
& Fabric Structures  
CORPORATE HEADQUARTERS  
2550 ESTERS BLVD., SUITE 100  
DFW AIRPORT, TX 75261  
800-966-5005

CERTIFICATIONS:

IAS CERTIFICATION No: FA-428  
CLARK COUNTY MANUFACTURER  
CERTIFICATION NUMBER (NEVADA): 355

REV	DESCRIPTION	DATE	DRW	CHK	ENG

Drawn By : YH 06/09/25  
Checked By : YH 06/09/25  
Approved By : YH 06/09/25

DRAWING DESCRIPTION:

**VIEWS**

DWG. **UT0625NH22835**

PAGE **1000**

REV.

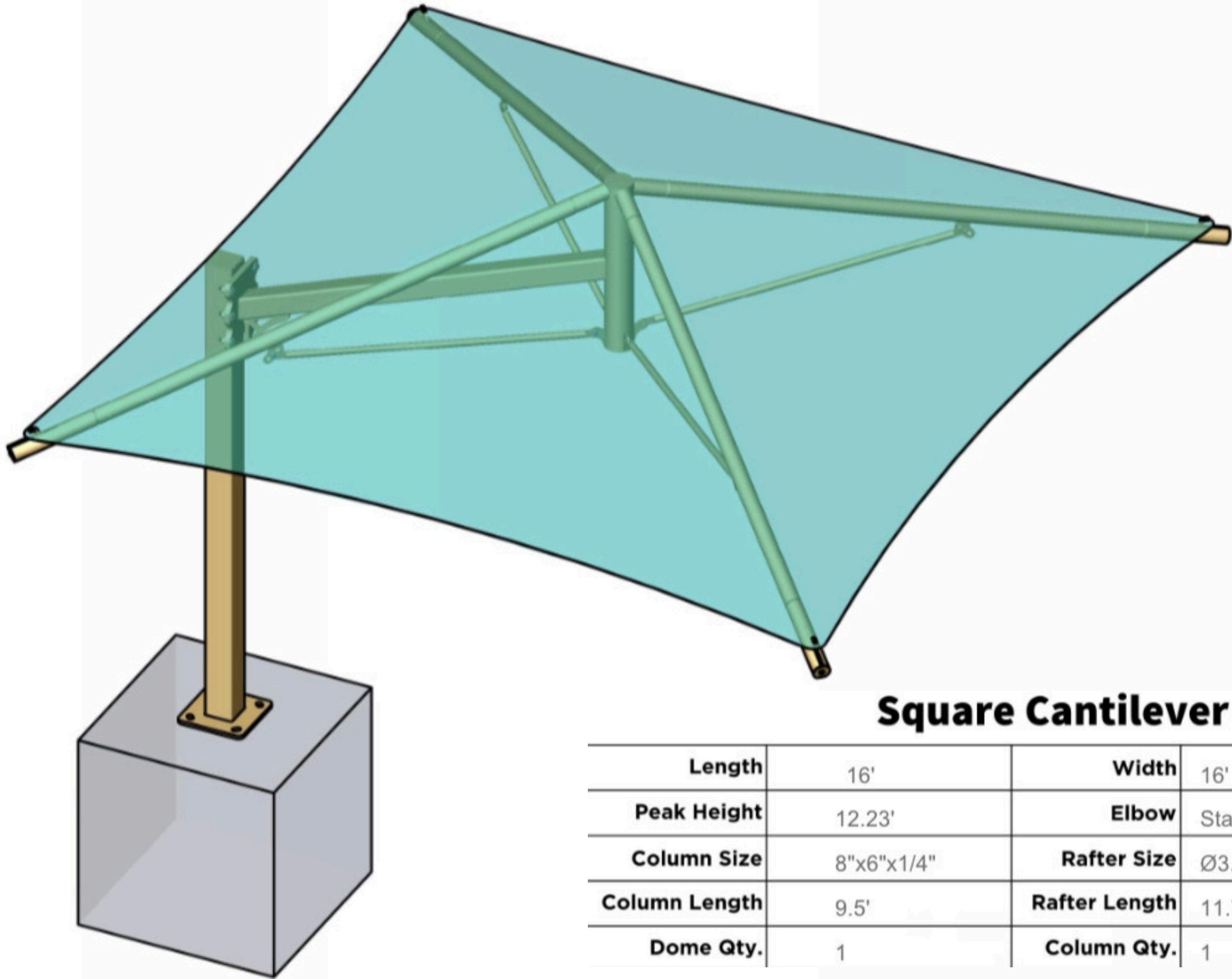

# SHADE

CIVIC CENTER  
UMBRELLA  
SHADES  
\$17,000/EACH

**Square Cantilever Umbrella Shade**

<b>Length</b>	16'	<b>Width</b>	16'	<b>Entry Height</b>	9'
<b>Peak Height</b>	12.23'	<b>Elbow</b>	Standard	<b>Column Mount</b>	Base Plate
<b>Column Size</b>	8"x6"x1/4"	<b>Rafter Size</b>	Ø3.5" 11-Ga	<b>Strut Size</b>	Ø1.9" 11-Ga
<b>Column Length</b>	9.5'	<b>Rafter Length</b>	11.79'	<b>Beam Size</b>	7"x5"x1/4"
<b>Dome Qty.</b>	1	<b>Column Qty.</b>	1		

## Square Cantilever Umbrella Shade

<b>Length</b>	16'	<b>Width</b>	16'	<b>Entry Height</b>	9'
<b>Peak Height</b>	12.23'	<b>Elbow</b>	Standard	<b>Column Mount</b>	Base Plate
<b>Column Size</b>	8"x6"x1/4"	<b>Rafter Size</b>	Ø3.5" 11-Ga	<b>Strut Size</b>	Ø1.9" 11-Ga
<b>Column Length</b>	9.5'	<b>Rafter Length</b>	11.79'	<b>Beam Size</b>	7"x5"x1/4"
<b>Dome Qty.</b>	1	<b>Column Qty.</b>	1		

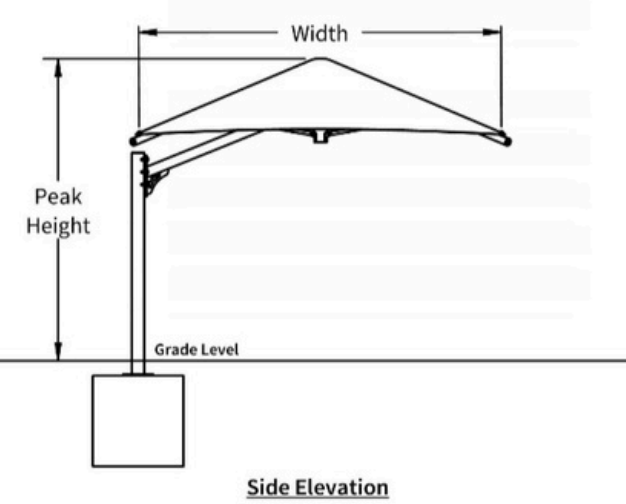
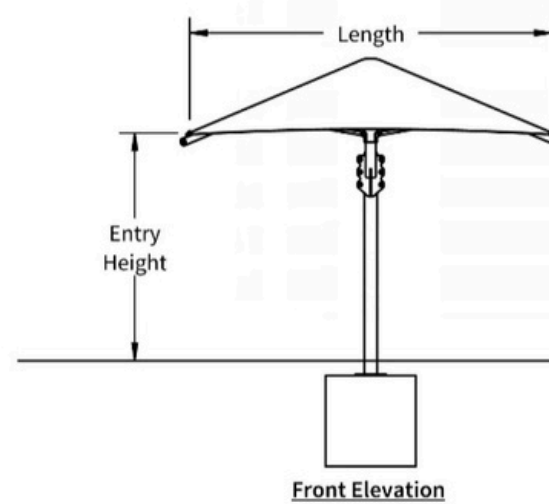
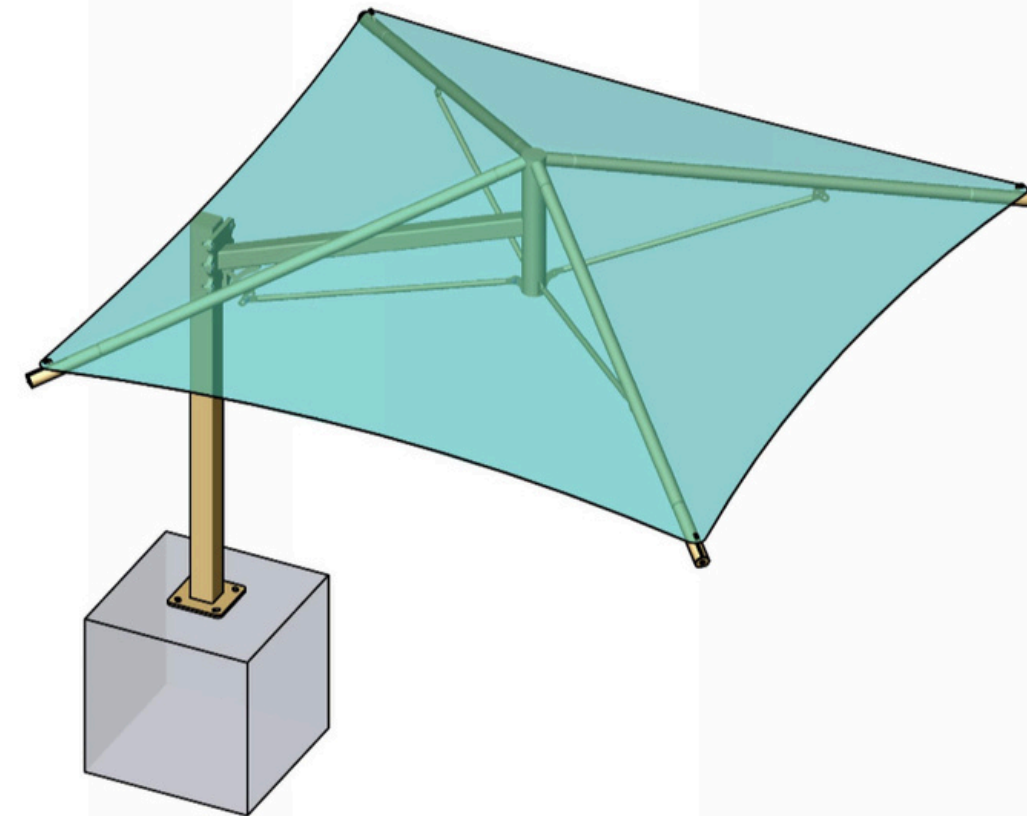

Column	Length & Width	Depth
Single Cap	4.62	3
Double Cap	N/A	3

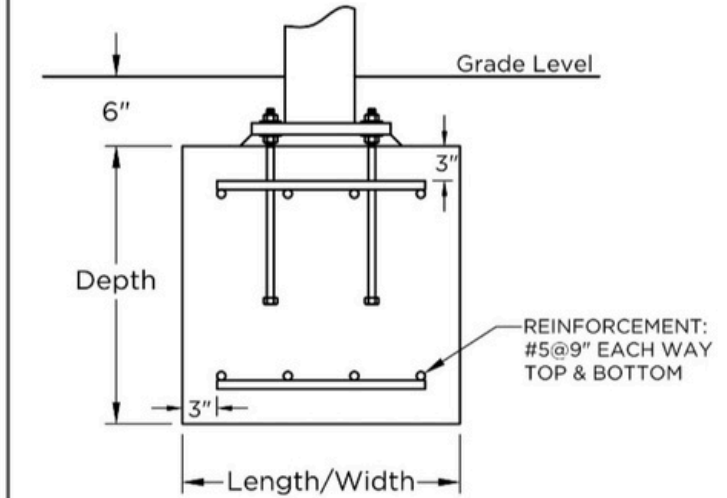

Diameter	Single Cap Depth	Double Cap Depth
1'-6"		
2'-0"	Out of range	N/A
2'-6"	Out of range	N/A
3'-0"	7.25	N/A

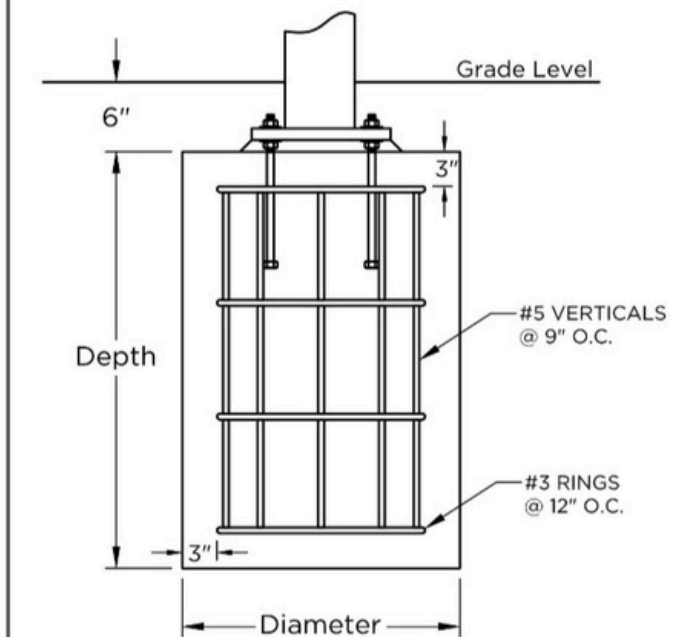

**Superior Shade**

QUOTE  
105334

SHADE SIZE  
16 X 16

SHADE STYLE  
Square Cantilever  
Umbrella Shade

*These drawings are for reference only and should not be used as construction details. They show the general character and rough dimensions of the structural features. Exact spans, fasteners, materials, and foundations can be determined by a licensed professional engineer upon request. Estimated footing size above is based on 1,500 PSF soil bearing pressure.*

# SHADE

## DUGOUT STYLE BENCH SHADE

- 14 X 14
  - \$8,893
- 14 X 10
  - \$7,576

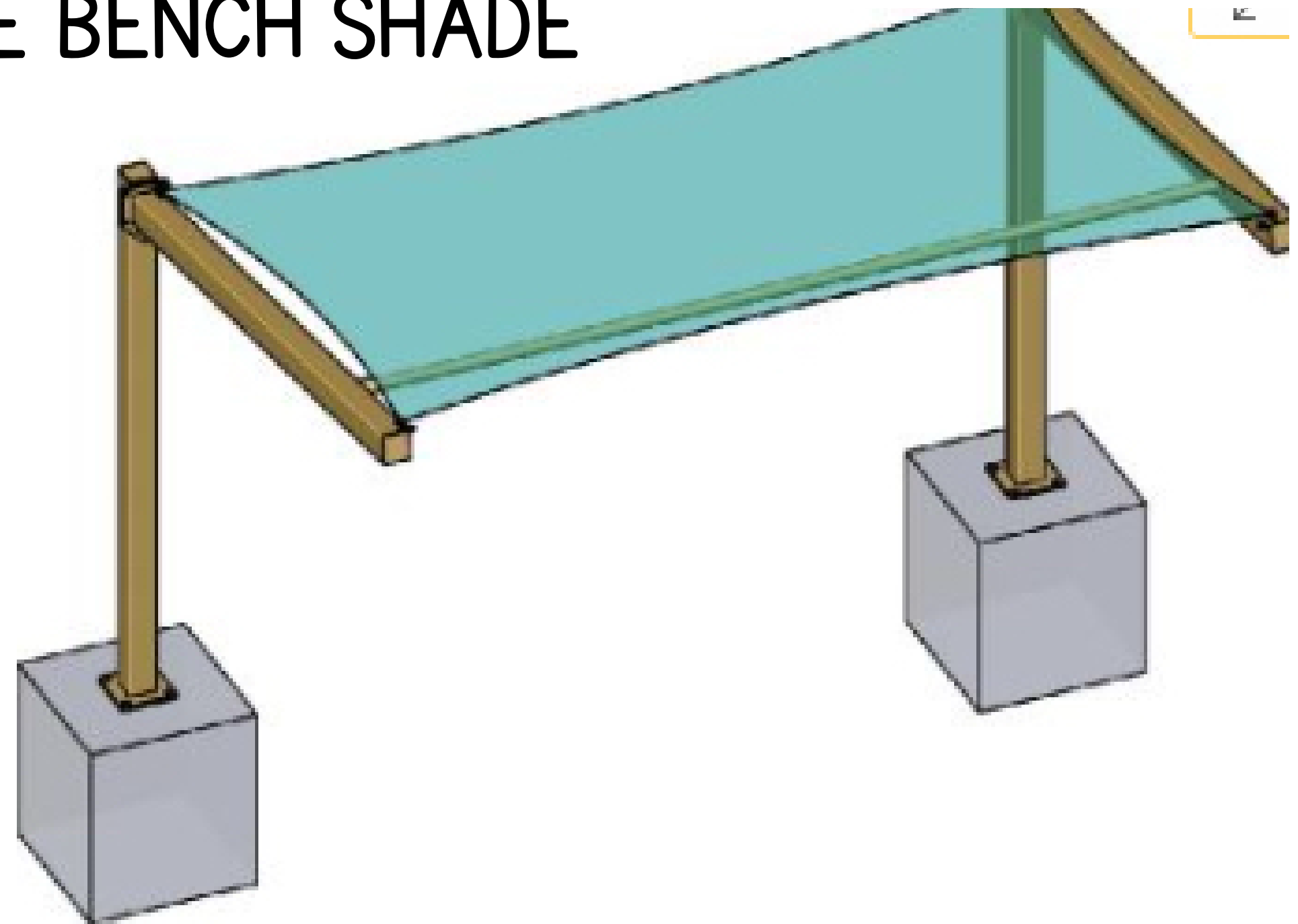

# SHADE

DUGOUT STYLE  
BENCH SHADE  
WITH BACKING

- ADTL \$900



# SHADE

“ROCK SOLID SWINGS”

- COMPOSITE WOOD
- POWDER-COATED METAL
- 3 YR WARRANTY INCLUDED
- MINIMAL MAINTENANCE
  - RE-STAINING
  - PRESSURE WASHING



# SHADE



# ARTS FUNDING

RAP TAX COMMITTEE REQUESTS

\$5,000 TO BE SET ASIDE FOR CLINTON CITY ARTS.

ARTS CURRENTLY OPERATES ON \$2,000 - \$2,500

YEARLY. THIS FUNDING ALLOWS FOR THEM TO

BRANCH OUT AND SUPPORTS:

EVENTS

ADVERTISING

SUPPLIES

# **GENERAL FUND**

**ANYTHING LEFT OVER IN THE BUDGET WILL BE LEFT IN THE GENERAL FUND. THIS WILL BE SET ASIDE FOR PUBLIC COMMENT SUGGESTIONS, EVENTS, SIGNAGE, AND MORE.**

# CLINTON CITY PROJECTS

RAP TAX COMMITTEE WOULD LIKE TO RECOMMEND  
\$75,000 BE ALLOCATED TO CLINTON CITY PROJECTS  
THAT FALL INTO RECREATION, ARTS, AND PARKS  
CATEGORIES, SUCH AS THE CLINTON POND PUMP  
TRACK PROJECT.

IN EXCHANGE THE RAP TAX COMMITTEE WOULD LIKE  
TO POST SPONSORSHIP SIGNAGE.

# RAP TAX SIGNAGE

SIGNAGE SUGGESTIONS INCLUDE:

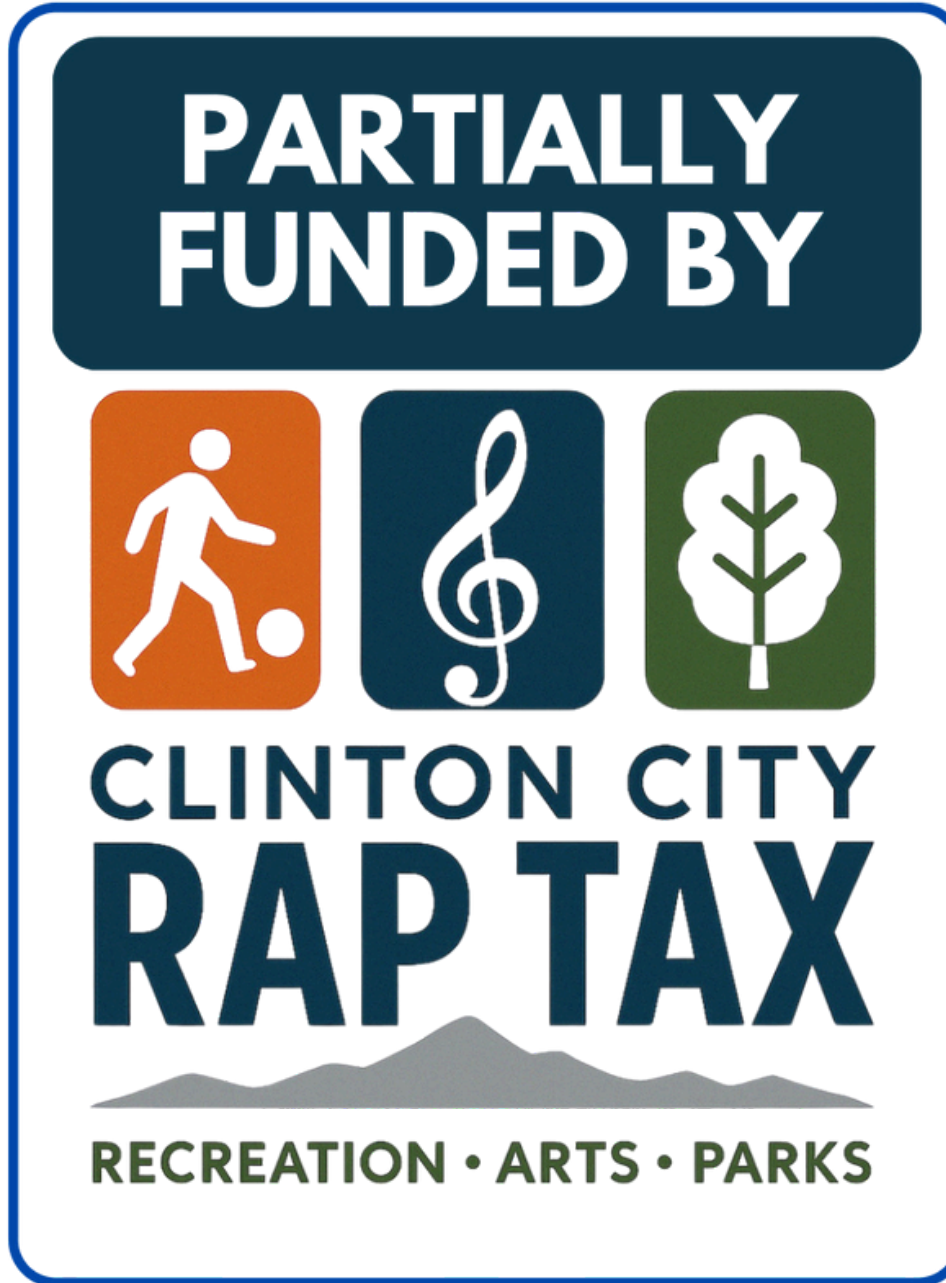

# FUNDING BREAKDOWN

\$75,000	CLINTON CITY PROJECTS
\$50,000	ROLLOVER
\$50,000	DOG PARK
\$51,000	SHADE
\$5,000	ARTS

---

**\$231,000 TOTAL PROJECTED**



**QUESTIONS?  
COMMENTS?  
CONCERNS?  
FEEDBACK?**



PUBLIC  
FINANCE  
ADVISORS



# SECONDARY WATER UTILITY FUND FINANCIAL PLAN

UPDATE TO 2022 ANALYSIS

**AUGUST 26, 2025**

# BACKGROUND: 2022 ANALYSIS

---

## □ D&W:

- **Performed a secondary water rate study to analyze revenues and expenditures to meet operations and management, capital improvements, secondary metering, and repair and replacement in 2022.**
- **Presented analysis in January 2023 and implemented new rate increases as a result**
- **Max rate increase was capped at 25%**
- **Intended to Review Rates within 5-year Planning Window**

# BACKGROUND: 2022 ANALYSIS

## □ D&W (CONT):

- **Since the last 2022 update:**
  - **Has received more secondary metering grants; and**
  - **Additional UDOT projects have been identified**
- **Based on updated assumptions, rate increases are only applicable to certain users based on lot size/connection size.**
  - **Capped Increase @ 10%**
- **Rate increases effective next D&W fiscal year (Sept/Oct 2025 billings for Nov 1 FY)**

# BACKGROUND: METERING

---

- In the 2022 Legislative Session, HB242 passed. This requires all secondary water services to be metered by December 31, 2029. After that, fees will be assessed to water providers not in compliance.
- D&W is working to complete meter projects and set-up water user portal.
- Next steps: Internally review base rates and tiers
  - HB274 passed in 2025, requiring tiered rates and water use to be billed based on the new meters starting in 2030. Next steps will be to collect data, analyze, and establish new rate tables.
  - Revisit Rates in FY2029

# 2025 SCENARIO UPDATE

## RECOMMENDED RATES: CLINTON

Lot Size in Acres		Reflects Increases in Assessments		
From	To	1-inch Connection	2-inch Connection	3-inch Connection
0	0.33	\$316	N/A	N/A
0.34	0.50	\$364	N/A	N/A
0.51	0.75	\$446	N/A	N/A
0.76	1.00	\$495	\$1,226	N/A
1.01	1.25	\$544	\$1,314	N/A
Greater than 1.25 Acre Connections				
1.26	1.50	\$753	\$1,396	N/A
1.51	1.75	\$841	\$1,499	N/A
1.76	2.00	\$929	\$1,599	\$2,601
2.01	2.25	\$1,018	\$1,687	\$2,687
2.26	2.50	\$1,106	\$1,775	\$2,782
2.51	2.75	\$1,194	\$1,864	\$2,884
2.76	3.00	\$1,282	\$1,952	\$2,987

# 2025 SCENARIO UPDATE

## RECOMMENDED RATES: CLINTON

Lot Size in Acres		Reflects Increases in Assessments								
		1-inch connection			2-inch connection			3-inch connection		
From	To	Existing Fee	Proposed Fee	% Change	Existing Fee	Proposed Fee	% Change	Existing Fee	Proposed Fee	% Change
0	0.33	\$316	\$316	0%	N/A	N/A	N/A	N/A	N/A	N/A
0.34	0.50	\$346	\$364	5%	N/A	N/A	N/A	N/A	N/A	N/A
0.51	0.75	\$405	\$446	10%	N/A	N/A	N/A	N/A	N/A	N/A
0.76	1.00	\$450	\$495	10%	\$1,226	\$1,226	0%	N/A	N/A	N/A
1.01	1.25	\$495	\$544	10%	\$1,314	\$1,314	0%	N/A	N/A	N/A
1.26	1.50	\$753	\$753	0%	\$1,396	\$1,396	0%	N/A	N/A	N/A
1.51	1.75	\$841	\$841	0%	\$1,499	\$1,499	0%	N/A	N/A	N/A
1.76	2.00	\$929	\$929	0%	\$1,599	\$1,599	0%	\$2,576	\$2,576	0%
2.01	2.25	\$1,018	\$1,018	0%	\$1,687	\$1,687	0%	\$2,679	\$2,679	0%
2.26	2.50	\$1,106	\$1,106	0%	\$1,775	\$1,775	0%	\$2,782	\$2,782	0%
2.51	2.75	\$1,194	\$1,194	0%	\$1,864	\$1,864	0%	\$2,884	\$2,884	0%
2.76	3.00	\$1,282	\$1,282	0%	\$1,952	\$1,952	0%	\$2,987	\$2,987	0%

# CLINTON CITY, UTAH

## 2025 Primary Election Official Results

Active Registered Voters	12,238
Total Ballots Cast	2,711
Percentage of Voter Turn out	22.15%
Ballots Cast by Mail	2,675
In Person Votes on Election Day	36
Precincts Reporting	22
Ballots Not Counted	26 (24 not timely, 1 blank envelope, 1 no proof of identity)

### City Council (2 four-year seats)

**Jennifer Steele Christensen	944
Robert Lee Eberhard	143
Shelby Montgomery	417
**Adam B Larsen	1,280
Cameron M Frick	164
Gary Lee Tyler	398
**Zackery M Hatch	596
**Chris Danson	1,044

(\*\* Moving on to General Election)

NOTICE IS HEREBY GIVEN THAT the Board of Canvassers for Clinton City has prepared a report of the election results for the General Election, held on Tuesday, August 5, 2025. A full report is available at [www.clintoncity.com](http://www.clintoncity.com) or in the Recorder's office at 2267 N 1500 W Clinton UT 84015; 801-614-0720.

Signed & attested this 26th day of August, 2025

  
\_\_\_\_\_  
Lisa Titensor, City Recorder



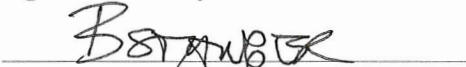

The Clinton City Board of Canvassers hereby certify that the information identified above is correct and represents the official results of the Clinton City Municipal Primary Election held on August 12, 2025.

Signed this 6<sup>th</sup> day of December 2023

  
\_\_\_\_\_  
Mayor Brandon Stanger

  
\_\_\_\_\_  
Austin Gray

  
\_\_\_\_\_  
Gary Tyler

  
\_\_\_\_\_  
Marie Dougherty

  
\_\_\_\_\_  
Dane Searle

  
\_\_\_\_\_  
Spencer Arave

# CLINTON CITY COUNCIL STAFF REPORT

2267 N 1500 W, Clinton, UT 84015

<b>MEETING DATE:</b>	September 9, 2025
<b>CONSENT AGENDA</b>	
<b>BUSINESS AGENDA</b>	a
<b>PETITIONER(S):</b>	Chief Poulsen
<b>TYPE OF VOTE:</b>	N/A
<b>SUBJECT:</b>	Fire Department Badge Pinning

## **RECOMMENDATION:**

**Badge Pinning**

## **FISCAL IMPACT:**

**None**

## **SUMMARY:**

**Deputy Fire Chief Nick Jarvis was hired as Deputy Chief.**

**Mike Jaramillo was hired as a Paramedic.**

**New Engineer still to be selected**

**Josh Rhees hired as Part-Time Firefighter**

**Levi Blough hired as Part-Time Firefighter**

**John Growcock hired as Part-Time Firefighter**

**Colby Bailey hired as Part-Time Firefighter**

**ATTACHMENTS: None**

# CLINTON CITY COUNCIL STAFF REPORT

2267 N 1500 W, Clinton, UT 84015

<b>MEETING DATE:</b>	September 9, 2025
<b>CONSENT AGENDA</b>	
<b>BUSINESS AGENDA</b>	b
<b>PETITIONER(S):</b>	Shawn Stoker, Chief of Police
<b>TYPE OF VOTE:</b>	NA
<b>SUBJECT:</b>	Lieutenant Badge Pinning

## RECOMMENDATION:

I respectfully recommend that we formally recognize the promotion of Jake Fowers to Lieutenant.

## FISCAL IMPACT:

Approved Budget, Salary Increase

## SUMMARY:

I am proud to announce the promotion of Jake Fowers to the rank of Lieutenant. The completed promotional process was thorough, competitive, and a clear reflection of the exceptional professionalism, leadership, and dedication demonstrated by every candidate. Lt. Fowers has continually exemplified the values and standards we hold as a department and city. His commitment to service, sound judgement, and strong leadership qualities will serve the citizens and department well.

## ATTACHMENTS:

-

-

# Clinton Parks - Cost Estimate by Phase

WORKSESSION DISCUSSION

11/23/2024

Prepared by: Seth Vance, Landscape Architect - Lead

J-U-B Engineers, Inc.

<b>MEADOWS PARK</b>		
<b>Phase</b>	<b>Total by Phase</b>	<b>Phase Description</b>
1	\$ 1,890,000.00	Large grass playfield (grading, sod, irrigation)
2	\$ 610,000.00	South parking lot, south trail section by parking, south landscape adjacent to parking
3	\$ 910,000.00	North parking lot, north trail section by parking & tying into existing trail, restroom, north landscape
0	\$ 3,410,000.00	
<b>POND PARK</b>		
<b>Phase</b>	<b>Total by Phase</b>	<b>Phase Description</b>
1	\$ 2,430,000.00	Parking, Playground, Large Pavilion, 1 Picnic Shelter, Restroom, Large berm, Asphalt perimeter trail, Site furnishings, landscape
2	\$ 790,000.00	Asphalt bike jump line, landscape
3	\$ 880,000.00	Asphalt pumptrack/deck, 1 picnic shelter, landscape
4	\$ 440,000.00	Pickleball courts, additional parking, landscape
0	\$ 4,540,000.00	
<b>LAND X</b>		
<b>Phase</b>	<b>Total by Phase</b>	<b>Phase Description</b>
1	\$ 2,020,000.00	South parking, Playground, Ninja course, Restroom, Landscape
2	\$ 1,360,000.00	North parking, Pavilion, Pickleball, 9-square, Stream area, Landscape
3	\$ 970,000.00	West parking, concrete sidewalk, landscape for fields
0	\$ 4,350,000.00	
<b>CIVIC CENTER</b>		
<b>Phase</b>	<b>Total by Phase</b>	<b>Phase Description</b>
1	\$ 250,000.00	Parking near Family Camp Pavilion
2	\$ 1,490,000.00	New skatepark where basketball court is
3	\$ 2,640,000.00	City plaza/gathering area
4	\$ 1,050,000.00	Grass playfields
5	\$7,000,000 - \$12,000,000	Recreation Building Expansion (Indoor Basketball Courts, Office, etc...)
High End Total		\$ 17,430,000.00
<b>SHOESTRING PARK</b>		
<b>Phase</b>	<b>Total by Phase</b>	<b>Phase Description</b>
1	\$ 510,000.00	Parking lot, dog park with small & large dogs, pavilion, sidewalks, landscape
0	\$ 510,000.00	

WORKSESSION DISCUSSION

Year	Project	Park	Est. Cost
	Volleyball pit lighting	Meadows	
	Irrigation Overhaul	Meadows	
	Additional Parking	Meadows	
	Replace restroom	Meadows	
	New Restroom	Meadows	
	Upgrade Trail Lighting	Meadows	
	Turf Overhaul	Meadows	
	Walking Path Overhaul (12')	Meadows	
	(4) small pavillions	Meadows	
	Shade structure pickelball sitting area	Meadows	
	Upgrade basketball hoops	Meadows	
	Cameras	Meadows	
	Autolocks on restrooms	Meadows	
	Tree Removal / repalce	Meadows	
	Tree Removal / repalce	Kiwanis	
	Replace Restroom	Kiwanis	
	(4) Upgrade / replace small bowerys	Kiwanis	
	Upgrade South fenceline	Kiwanis	
	Cameras	Kiwanis	
	auto locks on restrooms	Kiwanis	
	complex lighting	W. Clinton	
	Cameras	W. Clinton	
	Flag Pole	W. Clinton	
	Replace Scoreboards (2)	W. Clinton	
	Drinking Fountain @ bowery	W. Clinton	
	Replace playground w/ surfacing	W. Clinton	
	Replace (8) dugouts	W. Clinton	
	Curb cuts for access	Garden	
	Parking	Garden	
	Walking Path	Garden	
	Med size bowery (tables,lights,power)	Kestral	
	Cameras	Kestral	
	auto locks on restrooms	Kestral	
	Trail Lighting	Kestral	
	NE concrete connect to Trail	Kestral	
	Volleyball Lighting	Kestral	
	Main hill Water feature	Heritage	
	Chess Tables	Heritage	
	Updated Park Benches	Heritage	
	Entry Arbor	Heritage	
	auto locks on restrooms	Heritage	

Year	Project	Park	Est. Cost
	Volleyball pit lighting	Meadows	
	Irrigation Overhaul	Meadows	
	Additional Parking	Meadows	
	Replace restroom	Meadows	
	New Restroom	Meadows	
	Upgrade Trail Lighting	Meadows	
	Turf Overhaul	Meadows	
	Walking Path Overhaul (12')	Meadows	
	(4) small pavillions	Meadows	
	Shade structure pickelball sitting area	Meadows	
	Upgrade basketball hoops	Meadows	
	Cameras	Meadows	
	Autolocks on restrooms	Meadows	
	Tree Removal / repalce	Meadows	
	Tree Removal / repalce	Kiwanis	
	Replace Restroom	Kiwanis	
	(4) Upgrade / replace small bowerys	Kiwanis	
	Upgrade South fenceline	Kiwanis	
	Cameras	Kiwanis	
	auto locks on restrooms	Kiwanis	
	complex lighting	W. Clinton	
	Cameras	W. Clinton	
	Flag Pole	W. Clinton	
	Replace Scoreboards (2)	W. Clinton	
	Drinking Fountain @ bowery	W. Clinton	
	Replace playground w/ surfacing	W. Clinton	
	Replace (8) dugouts	W. Clinton	
	Curb cuts for access	Garden	
	Parking	Garden	
	Walking Path	Garden	
	Med size bowery (tables,lights,power)	Kestral	
	Cameras	Kestral	
	auto locks on restrooms	Kestral	
	Trail Lighting	Kestral	
	NE concrete connect to Trail	Kestral	
	Volleyball Lighting	Kestral	
	Main hill Water feature	Heritage	
	Chess Tables	Heritage	
	Updated Park Benches	Heritage	
	Entry Arbor	Heritage	
	auto locks on restrooms	Heritage	

	Replace Playground / surfacing	Heritage	
	Brick/rock Boweries post	Heritage	
	Dredge Pond	Pond	
	Fishing Piers	Pond	
	Bridge over Pond	Pond	
	Path Lights	Pond	
	Complete open area as drawn	Pond	
	Cameras	Pond	
	auto locks on restrooms	Pond	
	Drinking Fountain	Pond	
	Doggie Station w/ cans	Pond	
	Family camp parking	Civic	
	Finish Rec Berm	Civic	
25/26	Extend Rec parking to overflow area	Civic	
25/26	Replace playground w/ surfacing	Civic	
25/26	Over flow area (convert to Fields)	Civic	
	pathway lighting @ softball	Civic	
25/26	Perm Power East & West (Heritage Days)	Civic	
	Camera	Civic	
	auto locks on restrooms	Civic	
	Volleyball Lighting	Civic	
25/26	New Soccer Field	Powerline	
25/26	New Playground w/ surfacing	Powerline	
25/26	replace skate park	Powerline	
	Cameras	Powerline	
	Dog Park	Shoestring	
	Fence Upgrades	Shoestring	
	Parking	Shoestring	
	Benches / Cans	Shoestring	
	Cameras	Shoestring	
	Lighting	Shoestring	
	Drinking Fountain	Cranefield	
	Nine Square	Cranefield	
	Court Lights	Pioneer	
	Cameras	Pioneer	
	Benches / Cans / Doggie Stations	Canal	
	Fountains	Canal	
	1800 N Pickleball	OTHER	

# CLINTON CITY COUNCIL STAFF REPORT

2267 N 1500 W, Clinton, UT 84015

<b>MEETING DATE:</b>	September 9, 2025
<b>WORK SESSION</b>	
<b>PETITIONER(S):</b>	Brooke Mitchell – Recreation Director
<b>TYPE OF VOTE:</b>	NONE
<b>SUBJECT:</b>	Heritage Days Work Session/Discussion

## RECOMMENDATION:

1. The council change the name of the Clinton City summer celebration from Heritage Days to Clinton Days to better represent the type of celebration it is and unify the Clinton residents.
2. The council support the city employee's recommendations to change the event schedule for Heritage Days/Clinton Days to help keep our residents, families, police officers, fire department members, city employees, entertainers, vendors and council members safe while at the event.

## FISCAL IMPACT:

None currently.

## SUMMARY:

For many years, our city employees have observed a recurring issue during the Heritage Days celebration, particularly around 6:00 p.m. on Saturday evening. At this time, a large influx of teenagers arrives at the park. Unfortunately, a portion of this group does not come to participate in the celebration, but to fight and damage park facilities.

These teenagers mix in with families and community members who are at the park listening to the entertainment, enjoying the activities, visiting the vendors or simply sitting on the grass waiting to enjoy the firework show. Over the years, their actions have escalated and included carrying weapons, vandalizing city property, fighting, assaulting police officers, firefighters, and other employees, as well as launching fireworks into crowds, placing residents, employees and council members at risk.

From both personal interactions and police interviews with these individuals, it is clear that many of these teenagers attend events across different cities with the sole purpose of fighting. As the summer progresses, the number and intensity of these incidents typically

increase. A few years ago, we moved our celebration to the beginning of summer in an effort to curb this problem, which helped, but did not fully resolve the problem.

This year, Roy City attempted a different approach by ending its celebration and clearing their park at 6:00 p.m. before the fireworks went off later that evening. While they succeeded in clearing the park, the teenagers relocated to a nearby park and started fighting there. This highlights the challenge we face in maintaining a safe and enjoyable environment for our residents. Closing the park early is not a feasible option for our city because unlike Roy City our celebration is held at the same park the fireworks are shot off and viewed from. If we were to end the entertainment and vending early the vendors and entertainers would be trying to clean up and leave the park at the same time residents would be coming to the park to watch the fireworks causing unsafe conditions for our vendors, residents and employees.

To address this ongoing concern, we propose we adjust our summer celebration schedule by separating the fireworks from the rest of the activities and create a seating and standing only area for viewing the fireworks. This shift may help reduce or even eliminate the unsafe conditions we have experienced for years. We have consulted with the city attorney regarding the enforcement of designated seating and standing areas for the fireworks. They confirmed that, as long as we provide proper notice, we can legally enforce these areas.

Our goal is to ensure that the summer celebration remains a safe and enjoyable celebration for all families and community members. We believe this proposed change is an important step toward curbing or eliminating the safety concerns we have faced in the past.

**ATTACHMENTS:**

Schedule of Events for the 2026 Heritage Days/Clinton Days.

2026

# Clinton Days

June 8 - June 13

## Monday, June 8

**4 PM:** Golf Tournament

**6 PM:** 3.0 Pickleball Tournament

## Tuesday, June 9

**11 AM - 8 PM:** Art Night

**6 PM:** 3.5 Pickleball Tournament

## Wednesday, June 10

**6:30 PM - 8:30 PM:** Community Swim Night

## Thursday, June 11

**5 PM - 8 PM:** Car Show

**5:30 PM - 7:30 PM:** Band

**6 PM:** Community BBQ

**5 PM - 9 PM:** Fun Zone Inflatables

**5 PM - 9 PM:** Foam Extravaganza

**5 PM - 9 PM:** RGR Royal Gaming Rig

**5 PM - 9 PM:** The Photo Booth Bus

## Friday, June 12

**4:30 PM - 9:00 PM:** Basic & Food Vendors

**4:30 PM - 6:00 PM:** Entertainment on Stage

**5 PM - 9 PM:** Fun Zone Inflatables

**5 PM - 9 PM:** Foam Extravaganza

**5 PM - 9 PM:** The Photo Booth Bus

**5 PM - 9 PM:** RGR Royal Gaming Rig

**5 PM - 9 PM:** Kids Carnival Games

**7 PM - 9 PM:** Concert in the Park featuring

"Some Great Band"

**9 PM:** Movie in the Park

## Saturday, June 13

**7 AM:** 5K & 2 Mile Walk

**8 AM:** Kids' Dash

**9:45 AM:** Bike Parade

**10 AM:** Parade

**9:45 PM:** Fireworks or Drone Show



\*Subject to Change

# CLINTON CITY COUNCIL STAFF REPORT

---

2267 N 1500 W, Clinton, UT 84015

MEETING DATE:	September 9, 2025
AGENDA ITEM:	Discussion on Communications
PETITIONER(S):	Trevor Cahoon, City Manager
TYPE OF VOTE:	No Vote
SUBJECT:	Communication Expectations for the City Council

## RECOMMENDATION

Begin a discussion on communication expectations and limitations that we possess as a city and start understanding where we would like to see some progress being made in our outreach efforts.

## FISCAL IMPACT

None at this time.

## SUMMARY

The City has been working to diversify communication methods to better share information and encourage community engagement. We have experimented with newsletters, email and text alerts, social media platforms, podcasts, and short videos. These efforts demonstrate a recognition that residents receive information in many ways and expect timely, transparent updates from their local government.

Despite this progress, the City's overall communication efforts have been haphazard and lack coordination. Currently, communication responsibilities are spread across multiple departments and staff members without centralized oversight or a clear strategy. This "shotgun approach" has produced some successes, but it has also led to inconsistency in tone, branding, frequency, and effectiveness.

- **City Recorder's Office:** Oversees the newsletter, website, and Facebook page, and has responsibility for required noticing. Recently it was discovered that the email and text system had not been fully utilized, which is now being corrected.
- **Recreation Department:** Manages its own social media channels and email system, in addition to supporting the Recorder's office.

- **Police and Fire:** Operate separate Facebook pages focused on department-specific news and alerts.
- **Intern Support:** Helped pilot more modern formats (videos, podcasts) that added value to engagement. However, the intern's time has now ended, and there is no dedicated staff capacity to continue those efforts.
- **Elected Officials:** Both City Council members and the Mayor frequently share updates and information through their individual or official channels. This outreach is valuable and helps build direct connections with residents, but it also does not follow a unified strategy. As a result, messaging may at times be inconsistent with broader city communication or lack coordination with staff-driven efforts.

In addition, not all departments are trained on how to be effective communicators. Staff often do their best within their areas of responsibility, but without clear guidelines, training, or support, messaging can miss the mark or fail to reach the intended audience. This lack of structure also impacts the City Council, who rely on staff-prepared messaging and tools to connect with the community.

#### **KEY ISSUES**

- Decentralized communication responsibilities across multiple departments.
- Limited training in effective communication practices.
- Underutilization of existing tools (email, text, website).
- No clear accountability for communication strategy or standards.
- Loss of intern support, which had temporarily boosted outreach capacity.
- Uncoordinated messaging across both staff and elected official channels.

#### **NEXT STEPS / DISCUSSION POINTS**

Staff recommends the Council begin discussing how the City can bring more structure, consistency, and intentionality to its communications. Key questions include:

- Should the City designate a lead role or centralized responsibility for communication strategy?
- What expectations should be set for departments, staff, and elected officials when it comes to messaging, tone, and branding?
- How can we provide training and tools to ensure staff and Council are prepared to communicate effectively?
- What are our top priorities for communication (timeliness, consistency, transparency, engagement, etc.)?

- How can we make better use of platforms we already pay for (email, text, website) to maximize value?

By establishing clear expectations and building capacity, the City can move away from a piecemeal, shotgun approach toward a unified, strategic communication framework. This will not only help staff and departments but also strengthen the ability of the City Council and Mayor to connect with residents in a coordinated, effective way that builds trust and confidence in local government.